

# 40 SERIES GRAIN AUGER WAGONS AND UTILITY TRACKED CHASSIS

## OPERATOR & PARTS MANUAL

**M0158**

**Rev. 1/02**

This manual is applicable to: 640, 840 And 1040 Grain Auger Wagons  
*Model: AW Serial Number: 500690 and on*

Utility Tracked Chassis  
*Model: UTC Serial Number: 700000 and on*

Record the model number and serial number of your Grain Auger Wagon and/or Utility Tracked Chassis along with date purchased below:

Model Number _____ <b>AW</b> _____	Model Number _____ <b>UTC</b> _____
Serial Number _____	Serial Number _____
Date Purchased _____	Date Purchased _____

### SERIAL NUMBER

The serial number provides important information about your Grain Auger Wagon and/or Utility Tracked Chassis and may be required to obtain the correct replacement part.

The serial number plate is located on the right hand front corner of the Grain Auger Wagon frame and on the inside of the right hitch tube of the Utility Tracked Chassis. It is suggested that the serial number(s) be recorded in the space provided above. Always provide the serial number and model number when ordering parts from your KINZE® Dealer or anytime correspondence is made with KINZE Manufacturing, Inc.

58619-2a



**40 Series Grain Auger Wagon**

79970-13



**Utility Tracked Chassis**

*KINZE® is a registered trademark of KINZE Manufacturing, Inc.*

# TABLE OF CONTENTS

---

<b>TO THE OWNER</b> .....	1-1
<b>WARRANTY</b> .....	1-2
<b>INTRODUCTION</b> .....	2-1
<b>SPECIFICATIONS</b> .....	3-1
<b>SAFETY PRECAUTIONS</b>	
Grain Auger Wagon .....	4-1
Grain Auger Wagon Driveline .....	4-3
Utility Tracked Chassis .....	4-5
<b>SAFETY WARNING SIGNS</b> .....	5-1
<b>LUBRICATION</b>	
Drive Chain Oiler Operation .....	6-1
Drive Chains .....	6-1
Gearbox Oil Level .....	6-2
Grease Fittings/Lubrication Locations .....	6-3
Wheel Bearings .....	6-1
<b>OPERATION</b>	
Auger Cleanout Door (Grain Pit Unloading) .....	7-4
Driveline Inspection .....	7-4
Electronic Scale .....	7-5
Electronic Scale Print Options .....	7-7
Initial Preparation Of The Machine .....	7-1
Tractor Preparation And Hookup .....	7-1
Unloading The Auger Wagon .....	7-3
<b>MAINTENANCE</b>	
Auger Drive Chain Adjustment .....	8-2
Auger Timing .....	8-5
Axle Adjustment .....	8-8
Electronic Scale .....	8-10
Electronic Scale Troubleshooting .....	8-12
End Wheel/Mid Wheel Bearing Replacement (Sof-Trak Wagon/UTC) .....	8-14
Inside Tire Repair Or Removal (Row Crop Wagon) .....	8-7
Mounting Bolts And Hardware .....	8-1
Mud Scraper Adjustment (Sof-Trak Wagon/UTC - Rubber-Tire End Wheels Only) .....	8-5
Preparation For Storage .....	8-15
PTO Shear Bolt Protection .....	8-3
Tire Pressure .....	8-4
Tire Repair (Sof-Trak Wagon/UTC - Rubber-Tire End Wheels Only) .....	8-6
Torque Values Chart .....	8-1
Track Alignment (Sof-Trak Wagon/UTC) .....	8-6
Track Tension (Sof-Trak Wagon/UTC) .....	8-5
Vertical Auger Fold .....	8-2
Wheel Bearing Replacement (Wheel/Row Crop Wagon) .....	8-15
Wheel Nuts .....	8-4
Wiring Diagram .....	8-3
<b>PARTS LIST INDEX</b> .....	P1
<b>PARTS SECTION NUMERICAL INDEX</b> .....	a

# 40 Series Grain Auger Wagon PREDELIVERY/DELIVERY CHECKLIST

## TO THE DEALER

Predelivery service includes assembly, lubrication, adjustment and test. This service ensures that the wagon will be delivered to the customer ready for field use.

## PREDELIVERY CHECKLIST

After the wagon has been completely assembled, use the following checklist and inspect the wagon. Check off each item as it is found satisfactory or after proper adjustment is made.

- Wheel nuts are torqued to 425 ft. lbs.
- Axles are adjusted from shipping position to desired operating position.
- Tires are inflated to specified PSI air pressure.
- Chains are aligned and properly tensioned.
- All grease fittings have been lubricated, gearbox oil level checked and chain oiler filled.
- Check to be sure all safety decals are correctly located and legible. Replace if damaged.
- Check to be sure all reflective decals are correctly located.
- Check to be sure SMV decal is in place and shipping cover removed.
- Check to be sure safety/warning lights are working properly.
- Test run the augers.
- Check driveline. See "Driveline Inspection" in Operation Section.
- Check track alignment. See "Track Alignment" in Maintenance Section. (If Applicable)
- Check to be sure safety screens over horizontal augers are in place.
- Paint all parts scratched in shipment.
- Check to be sure outboard single amber light assemblies are located correctly for axle width. See "Axle Adjustment" in Maintenance Section.

***This wagon has been thoroughly checked and to the best of my knowledge is ready for delivery to the customer.***

\_\_\_\_\_  
(Signature Of Set-Up Person/Dealer Name/Date)

## OWNER REGISTER

Name \_\_\_\_\_ Date Sold \_\_\_\_\_

Street Address \_\_\_\_\_ Model No. \_\_\_\_\_ Serial No. \_\_\_\_\_

City, State/Province \_\_\_\_\_ Dealer Name \_\_\_\_\_

ZIP/Postal Code \_\_\_\_\_ Dealer No. \_\_\_\_\_

## DELIVERY CHECKLIST

At the time the wagon is delivered, the following checklist is a reminder of very important information which should be conveyed directly to the customer. Check off each item as it is fully explained to the customer.

- Advise the customer that the durability and longevity of this or any other machine is dependent on regular maintenance as directed in the Operator & Parts Manual.
- Tell the customer about all safety precautions that must be observed while using this wagon.
- Advise the customer of the specified tractor requirement for use with this wagon.
- Check axle spacing with customer to be sure axle is adjusted from shipping position to desired operating width.
- Along with the customer check to be sure all reflective decals and SMV sign are clearly visible with the auger wagon attached to the tractor. Check to be sure the safety/warning lights are in working condition. Tell the customer to check and follow federal, state/provincial and local regulations before towing on a road or highway.
- Along with the customer check to be sure the hitch height when attached to the tractor is sufficient to prevent severe bends in PTO U-joint angles. Check to be sure PTO is correct length for making turns and operating on uneven terrain.
- Complete Warranty And Delivery Report form.
- Give the Operator & Parts Manual to the customer and explain all operating adjustments.

***To the best of my knowledge this machine has been delivered ready for field use and customer has been fully informed as to proper care and operation.***

---

(Signature Of Delivery Person/Dealer Name/Date)

## AFTER DELIVERY CHECKLIST

The following is a list of items we suggest to check during the first season of use of the equipment.

- Check with the customer as to the performance of the wagon.
- Review with the customer the importance of proper maintenance and adherence with all safety precautions.
- Check for parts that may need to be adjusted or replaced.
- Retorque all wheel nuts to 425 ft. lbs.
- Check to be sure all safety shields and screens are in place.
- Check to be sure all safety decals, reflective decals and the SMV sign are correctly located and legible. Replace if damaged or missing.
- Check to be sure safety/warning lights are properly installed and working properly.
- Check to be sure recommended lubrication procedures are being followed.

---

(Signature Of Follow-Up Person/Dealer Name/Date)

**RETURN THIS COMPLETED FORM TO KINZE® IMMEDIATELY, along with Warranty And Delivery Report.  
Retain photocopy of this form at dealership for After Delivery Check.**

*Tear Along Perforation*



# Utility Tracked Chassis PREDELIVERY/DELIVERY CHECKLIST

## TO THE DEALER

Predelivery service includes assembly, lubrication, adjustment and test. This service ensures that the chassis will be delivered to the customer ready for use.

## PREDELIVERY CHECKLIST

After the chassis has been completely assembled, use the following checklist and inspect the chassis. Check off each item as it is found satisfactory or after proper adjustment is made.

- Wheel nuts are torqued to 425 ft. lbs.
- Axles are adjusted from shipping position to desired operating position.
- Tires are inflated to specified PSI air pressure.
- All grease fittings have been lubricated.
- Check to be sure track alignment is correct. See "Track Alignment" in Maintenance Section.
- Check to be sure all safety decals are correctly located and legible. Replace if damaged.
- Check to be sure all reflective decals are correctly located.
- Paint all parts scratched in shipment.
- Check to be sure customer-supplied safety/warning lights are located correctly.

***This chassis has been thoroughly checked and to the best of my knowledge is ready for delivery to the customer.***

---

(Signature Of Set-Up Person/Dealer Name/Date)

## OWNER REGISTER

Name \_\_\_\_\_ Date Sold \_\_\_\_\_  
Street Address \_\_\_\_\_ Model No. \_\_\_\_\_ Serial No. \_\_\_\_\_  
City, State/Province \_\_\_\_\_ Dealer Name \_\_\_\_\_  
ZIP/Postal Code \_\_\_\_\_ Dealer No. \_\_\_\_\_

## DELIVERY CHECKLIST

At the time the chassis is delivered, the following checklist is a reminder of very important information which should be conveyed directly to the customer. Check off each item as it is fully explained to the customer.

- Advise the customer that the durability and longevity of this or any other machine is dependent on regular maintenance as directed in the Operator & Parts Manual.
- Tell the customer about all safety precautions that must be observed while using this machine.
- Check axle spacing with customer to be sure axle is adjusted from shipping position to desired operating width.
- Along with the customer check to be sure all reflective decals are clearly visible when attached to the tractor. Check to be sure customer-supplied safety/warning lights and customer-supplied SMV sign have been installed and are in working condition (If Applicable). Tell the customer to check and follow federal, state/provincial and local regulations before towing on a road or highway.
- Complete Warranty And Delivery Report form.
- Give the Operator & Parts Manual to the customer and explain all operating adjustments.

***To the best of my knowledge this machine has been delivered ready for use and customer has been fully informed as to proper care and operation.***

---

(Signature Of Delivery Person/Dealer Name/Date)

## AFTER DELIVERY CHECKLIST

The following is a list of items we suggest to check during the first month of use of the equipment.

- Check with the customer as to the performance of the chassis.
- Review with the customer the importance of proper maintenance and adherence with all safety precautions.
- Check for parts that may need to be adjusted or replaced.
- Retorque all wheel nuts to 425 ft. lbs.
- Check to be sure all safety shields and screens are in place.
- Check to be sure all safety decals and reflective decals are correctly located and legible. Replace if damaged or missing.
- Check to be sure customer-supplied safety/warning lights are properly installed and are working properly. (If Applicable)
- Check to be sure customer-supplied SMV sign is correctly located and visible. (If Applicable)
- Check to be sure recommended lubrication procedures are being followed.

---

(Signature Of Follow-Up Person/Dealer Name/Date)

**RETURN THIS COMPLETED FORM TO KINZE® IMMEDIATELY, along with Warranty And Delivery Report.  
Retain photocopy of this form at dealership for After Delivery Check.**

*Tear Along Perforation*

# TO THE OWNER

---

KINZE Manufacturing, Inc. would like to thank you for your patronage. We appreciate your confidence in KINZE® equipment. Your KINZE® Grain Auger Wagon and/or Utility Tracked Chassis has been carefully designed and sturdily built to provide dependable operation in return for your investment.

**This manual has been prepared to aid you in the operation and maintenance of the Grain Auger Wagon and/or Utility Tracked Chassis. It should be considered a permanent part of the machine and remain with the machine when you sell it.**

It is the responsibility of the user to read and understand the Operator & Parts Manual in regards to safety, operation, lubrication and maintenance prior to operation of this equipment. It is the user's responsibility to inspect and service the machine routinely as directed in the Operator & Parts Manual. We have attempted to cover all areas of safety, operation, lubrication and maintenance; however, there may be times when special care must be taken to fit your conditions.

Throughout this manual the symbol  and the words **NOTE, IMPORTANT, CAUTION, WARNING and DANGER** are used to call your attention to important information. The definition of each of these terms follows:

**NOTE:** Indicates a special point of information or addresses a machine adjustment.

**IMPORTANT:** Indicates information which, if not heeded, could result in damage to the machine.



**CAUTION:** Indicates a potentially hazardous situation which, if not avoided, may result in minor or moderate personal injury.



**WARNING:** Indicates a potentially hazardous situation which, if not avoided, could result in death or serious personal injury.



**DANGER:** Indicates an imminently hazardous situation which, if not avoided, will result in death or serious personal injury.

**CAUTION:** It is anticipated that modifications and attachments will be added to the KINZE® Utility Tracked Chassis. KINZE Manufacturing, Inc. will not be responsible for the safety, performance or conditions created by these modifications and attachments individually or the completed machine.



**WARNING:** Some photos in this manual may show safety covers or shields removed for visual clarity. **NEVER OPERATE** the machine without all safety covers and shields in place.

NOTE: Some photos in this manual may have been taken of prototype machines. Production machines may vary in appearance.

NOTE: Some photos and illustrations in this manual show optional attachments installed. Contact your KINZE® Dealer for purchase of optional attachments.



**DANGER:** Because of load capacities on bridges and roads and because the machine is not equipped with brakes, the machine is not intended for hauling loads on public roadways. It is the operator's responsibility to be aware of and follow federal, state/provincial and local regulations in this regard.

# WARRANTY

---

The KINZE® Limited Warranty for your new machine is stated on the back of the retail purchaser's copy of the Warranty And Delivery Report form. Additional copies of the Limited Warranty can be obtained through your KINZE® Dealer.

Warranty, within the warranty period, is provided as part of KINZE's support program for registered KINZE® products which have been operated and maintained as described in this manual. Evidence of equipment abuse or modification beyond original factory specifications will void the warranty. Normal maintenance, service and repair is not covered by KINZE® warranty.

To register your KINZE® product for warranty, a Warranty And Delivery Report form must be completed by the KINZE® Dealer and signed by the retail purchaser, with copies to the Dealer, to the retail purchaser and to KINZE Manufacturing, Inc. Registration must be completed and sent to KINZE Manufacturing, Inc. within 30 days of delivery of the KINZE® product to the retail purchaser. KINZE Manufacturing, Inc. reserves the right to refuse warranty on serial numbered products which have not been properly registered.

If service or replacement of failed parts which are covered by the Limited Warranty are required, it is the user's responsibility to deliver the machine along with the retail purchaser's copy of the Warranty And Delivery Report to the KINZE® Dealer for service. KINZE® warranty does not include cost of travel time, mileage, hauling or labor. Any prior arrangement made between the Dealer and the retail purchaser in which the Dealer agrees to absorb all or part of this expense should be considered a courtesy to the retail purchaser.

*KINZE® warranty does not include cost of travel time, mileage, hauling or labor.*

# INTRODUCTION

This manual has been written to cover the KINZE® Model 640, 840 and 1040 Grain Auger Wagons and Utility Tracked Chassis.

The information and photos used in this manual were current at the time of printing. However, due to KINZE's continual attempt to improve its product, possible production changes may cause your machine to appear slightly different in detail. KINZE Manufacturing, Inc. reserves the right to change specifications or design without notice and without incurring obligation to install the same on machines previously manufactured.

Right hand (R.H.) and left hand (L.H.), as used throughout this manual, is determined by facing in the direction the machine will travel when in use, unless otherwise stated.

538811c



**640 Wheel Wagon**

5388112c



**840 Wheel Wagon**

5957710c



**840 Row Crop Wagon**

621812d



**640 Sof-Trak Wagon**

00136-99c

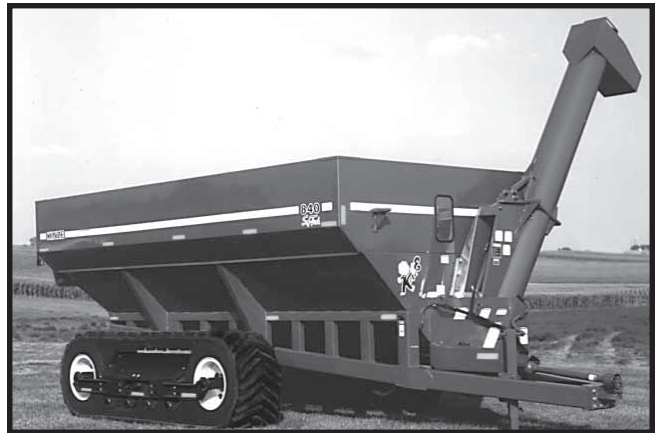

**840 Sof-Trak Wagon**

5861918d



**1040 Row Crop Wagon**

# INTRODUCTION

---

LF61-96b

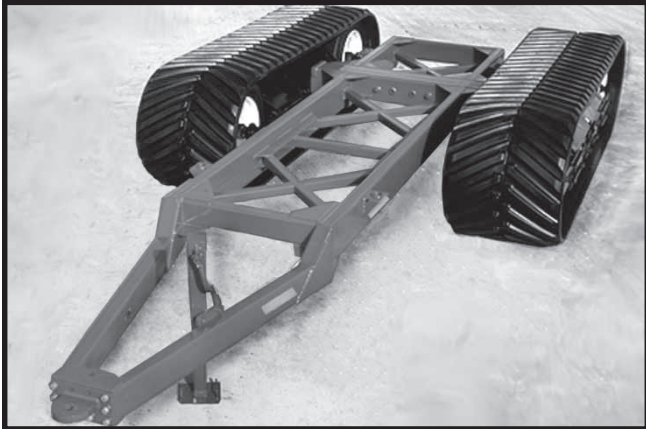

**Utility Tracked Chassis**

LFF3-96b



**Utility Tracked Chassis  
With 840 Wagon  
(1040 Wagon Not Shown)**



# SPECIFICATIONS

# GRAIN AUGER WAGON

RH490(WGN1a)

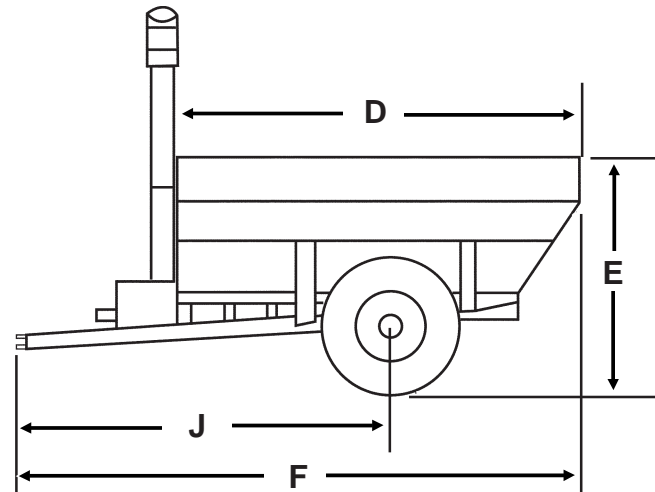
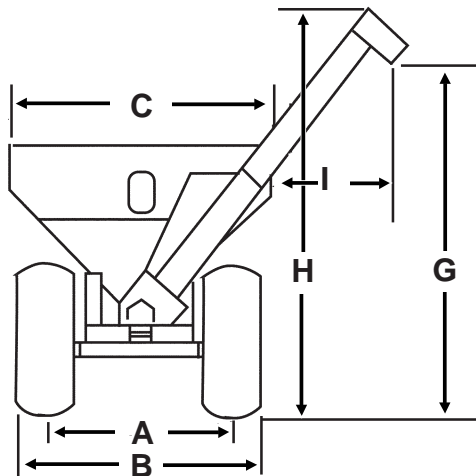

SIZES		640 Wheel	840 Wheel
(A) Tire Center-To-Center(Adjustable)		108" Or 120"	108" Or 120"
(B) Transport Width, 108" Axle Setting		11' 0" (24.5" x 32" Tires)	11' 6"
Transport Width, 120" Axle Setting		12' 0" (24.5" x 32" Tires)	12' 6"
(C) Width - Grain Tank		10' 0"	10' 0"
(D) Length - Grain Tank		16' 0"	20' 0"
(E) Height - Grain Tank		9' 2"	9' 6"
(F) Total Length		23' 2"	27' 0"
(G) Height - Auger Discharge		12' 3"	11' 10"
(H) Height - Top Of Auger		15' 0"	15' 5"
(I) Side Of Wagon To Tip Of Spout		4' 7"	5' 0"
(J) Axle Center To Tip Of Hitch		14' 6"	18' 0"
Wagon Weight - Empty		8136 Lbs.	11,634 Lbs.
Hitch Weight - Empty		1760 Lbs.	2200 Lbs.
Hitch Weight - Loaded		3920 Lbs.	5950 Lbs.
Total Capacity*		625 Bu.	825 Bu.
Bushels/Minute - Max.*		210 Bu./Min.	290 Bu./Min.
Vertical Auger		14" Full Pitch R.H.	16" Full Pitch R.H.
Horizontal Auger	Front	12" Full Pitch L.H.	12" Full Pitch L.H.
	Rear	12"- <sup>2</sup> / <sub>3</sub> Pitch L.H.	12"- <sup>2</sup> / <sub>3</sub> Pitch L.H.
Flighting	12"-14"	<sup>3</sup> / <sub>8</sub> " Helicoid	<sup>3</sup> / <sub>8</sub> " Helicoid
	16"	-	<sup>7</sup> / <sub>16</sub> " Helicoid
Gearbox		A-11 Heavy Duty	A-76 Heavy Duty
Chain		No. 80 Roller	Double No. 80 Roller
Sprockets		Industrial Grade With Taper-Lock Bushings	
Bearings		1 1/2" - 2"	2" - 2 7/16"
PTO - 1000 RPM (U-Joint W/Shaft Shear)		80 HP Rated	160 HP Rated
PTO Yoke		1 3/8"-21 Spline Or 1 3/4"-20 Spline	
Hydraulic Flow Control		Standard	Standard
Tires (NOTE: 30.5" x 32" tires on 640 wagon and 30.5" x 32" R-1 tires on 840 wagon require 120" axle settings.)		**24.5" x 32" 12/16 Ply (2)	**30.5" x 32" 12/16 Ply (2)
		**30.5" x 32" 12/16 Ply (2)	-
Spindle/Hub		4 1/2" - 10 Bolt (2)	4 1/2" - 10 Bolt (2)
Hitch Clevis		Bolt-On Single Or Double Clevis Or Single Clevis Swivel	
Windows		Standard Front And Rear - All Sizes	
Chain/Oiler/Lube Bank		Standard	Standard
Parking Jack		7000 Lb. Drop Leg	10,000 Lb. Drop Leg
Lights		Safety/Warning Lights Standard - Work Lights Optional	
Scale Option		Factory Or Field Installation	
Tractor Requirement (Minimum)		125 - 175 HP	175 HP 2WD/4WD

\* Approximate with 15% moisture corn. Bushels and bushels/minute will vary with moisture content of grain and/or RPM.

\*\* R-1 traction tread or R-3 diamond tread.

# SPECIFICATIONS

# GRAIN AUGER WAGON

RH490st(WGN2a)

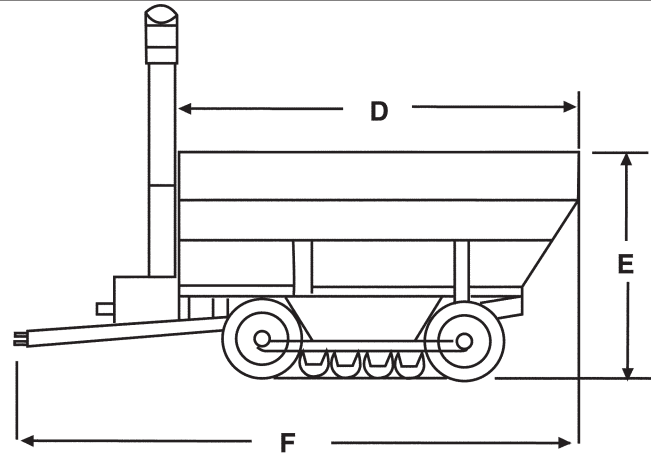
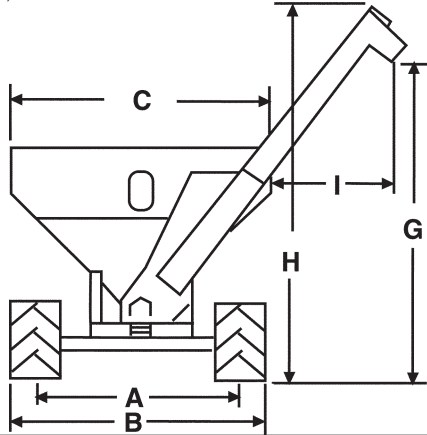

SIZES		640 Sof-Trak	840 Sof-Trak
(A) Track Center-To-Center (Adjustable)		108" Or 120"	108" Or 120"
(B) Transport Width, 108" Axle Setting (24"/36" Track)		11' 0"/12' 0"	11' 0"/12' 0"
Transport Width, 120" Axle Setting (24"/36" Track)		12' 0"/13' 0"	12' 0"/13' 0"
(C) Width - Grain Tank		10' 0"	10' 0"
(D) Length - Grain Tank		16' 0"	20' 0"
(E) Height - Grain Tank		9' 2"	9' 6"
(F) Total Length		23' 2"	27' 0"
(G) Height - Auger Discharge		12' 3"	11' 10"
(H) Height - Top Of Auger		15' 0"	15' 5"
(I) Side Of Wagon To Tip Of Spout		4' 7"	5' 0"
Wagon Weight - Empty**		15,114 Lbs.	18,245 Lbs.
Hitch Weight - Empty		1760 Lbs.	2200 Lbs.
Hitch Weight - Loaded		3920 Lbs.	5950 Lbs.
Total Capacity*		625 Bu.	825 Bu.
Bushels/Minute - Max.*		210 Bu./Min.	290 Bu./Min.
Vertical Auger		14" Full Pitch R.H.	16" Full Pitch R.H.
Horizontal Auger	Front	12" Full Pitch L.H.	12" Full Pitch L.H.
	Rear	12" <sup>-2/3</sup> Pitch L.H.	12" <sup>-2/3</sup> Pitch L.H.
Flighting	12"-14"	3/8" Helicoid	3/8" Helicoid
	16"	-	7/16" Helicoid
Gearbox		A-11 Heavy Duty	A-76 Heavy Duty
Chain		No. 80 Roller	Double No. 80 Roller
Sprockets		Industrial Grade With Taper-Lock Bushings	
Bearings		1 1/2" - 2"	2" - 2 7/16"
PTO - 1000 RPM (U-Joint W/Shaft Shear)		80 HP Rated	160 HP Rated
PTO Yoke		1 3/8"-21 Spline Or 1 3/4"-20 Spline	
Hydraulic Flow Control		Standard	Standard
Track	Width	24" or 36"	24" or 36"
	Length - Overall	153"	153"
	Length - Contact	108"	108"
	End Wheels	***8.25" x 20" Or 9" x 22.5"(8)/****Cast Iron - Semented(4 Sets)	
	Mid Wheels	16" Steel (8)	16" Steel (8)
Hitch Clevis		Bolt-On Single Or Double Clevis Or Single Clevis Swivel	
Windows		Standard Front And Rear - All Sizes	
Chain/Oiler/Lube Bank		Standard	Standard
Parking Jack		7000 Lb. Drop Leg	10,000 Lb. Drop Leg
Lights		Safety/Warning Lights	Standard - Work Lights Optional
Scale Option		Not Available	Not Available
Tractor Requirement (Minimum)		125 - 175 HP	175 HP 2WD/4WD

\* Approximate with 15% moisture corn. Bushels and bushels/minute will vary with moisture content of grain and/or RPM.

\*\* 36" track equipped machines add 1,110 lbs.

\*\*\* Smooth or treaded truck tire.

\*\*\*\* 36 1/2" diameter.



# SPECIFICATIONS

# GRAIN AUGER WAGON

RH490d(WGN3a)

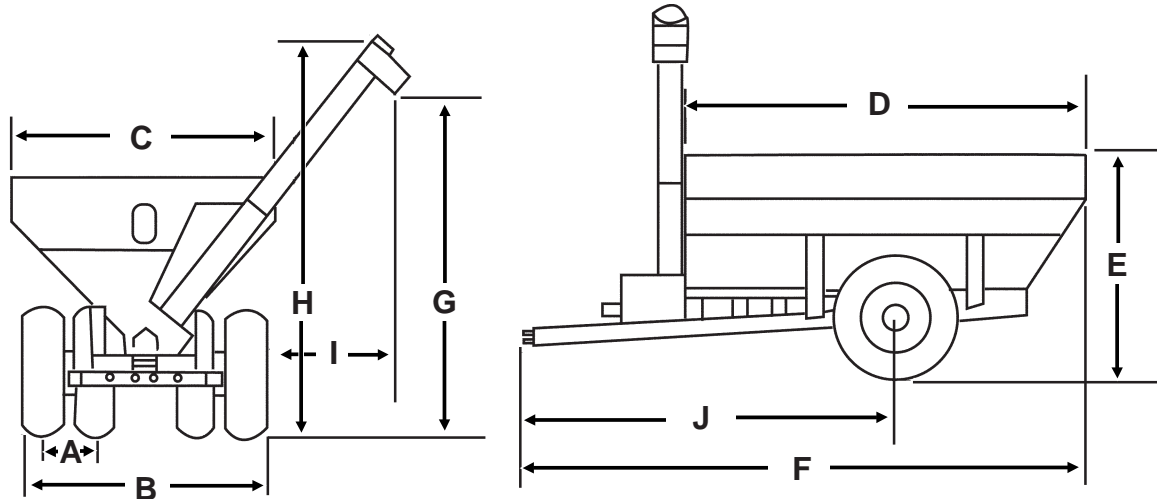

SIZES	840 Row Crop	1040 Row Crop
(A) Tire Center-To-Center (Adjustable)**	30" or 37 1/2"	30" or 37 1/2"
(B) Transport Width, 30" Row	11' 9"	11' 9"
Transport Width, Wide Row	13' 11"	13' 11"
(C) Width - Grain Tank	10' 0"	11' 0"
(D) Length - Grain Tank	20' 0"	20' 0"
(E) Height - Grain Tank	9' 8"	10' 8"
(F) Total Length	27' 0"	27' 0"
(G) Height - Auger Discharge	11' 10"	11' 10"
(H) Height - Top Of Auger	15' 5"	15' 5"
(I) Side Of Tire To Tip Of Spout	30" Row 4' 6"	4' 6"
Wide Row	3' 3"	3' 3"
(J) Axle Center To Tip Of Hitch	18' 0"	18' 0"
Wagon Weight - Empty	15,852 Lbs.	15,992 Lbs.
Hitch Weight - Empty	2200 Lbs.	2250 Lbs.
Hitch Weight - Loaded	5950 Lbs.	7240 Lbs.
Total Capacity*	810 Bu.	970 Bu.
Bushels/Minute - Max.*	290 Bu./Min.	290 Bu./Min.
Vertical Auger	16" Full Pitch R.H.	16" Full Pitch R.H.
Horizontal Auger	Front 12" Full Pitch L.H.	12" Full Pitch L.H.
Rear	12" -2/3 Pitch L.H.	12" -2/3 Pitch L.H.
Flighting	12" 3/8" Helicoid	3/8" Helicoid
16"	7/16" Helicoid	7/16" Helicoid
Gearbox	A-76 Heavy Duty	A-76 Heavy Duty
Chain	Double No. 80 Roller	Double No. 80 Roller
Sprockets	Industrial Grade With Taper-Lock Bushings	
Bearings	2" - 2 7/16"	2" - 2 7/16"
PTO - 1000 RPM (U-Joint W/Shaft Shear)	160 HP Rated	160 HP Rated
PTO Yoke	1 3/8"-21 Spline Or 1 3/4"-20 Spline	
Hydraulic Flow Control	Standard	Standard
Tires	***18.4" x 38" 14 Ply/Radial (4)	***18.4" x 38" 14 Ply/Radial (4)
Spindle/Hub	4 1/2" - 10 Bolt (4)	4 1/2" - 10 Bolt (4)
Hitch Clevis	Bolt-On Single Or Double Clevis Or Single Clevis Swivel	
Windows	Standard Front And Rear - All Sizes	
Chain/Oiler/Lube Bank	Standard	Standard
Parking Jack	10,000 Lb. Drop Leg	10,000 Lb. Drop Leg
Lights	Safety/Warning Lights Standard - Work Lights Optional	
Scale Option	Factory Or Field Installation	
Tractor Requirement (Minimum)	175 HP 2WD/4WD	225 HP 4WD

\* Approximate with 15% moisture corn. Bushels and bushels/minute will vary with moisture content of grain and/or RPM.

\*\* Duals may be adjusted to center over 30" or wide rows.

\*\*\* R-1 traction-tread.

# SPECIFICATIONS

# UTILITY TRACKED CHASSIS

AL/RH294a(WGN4a)

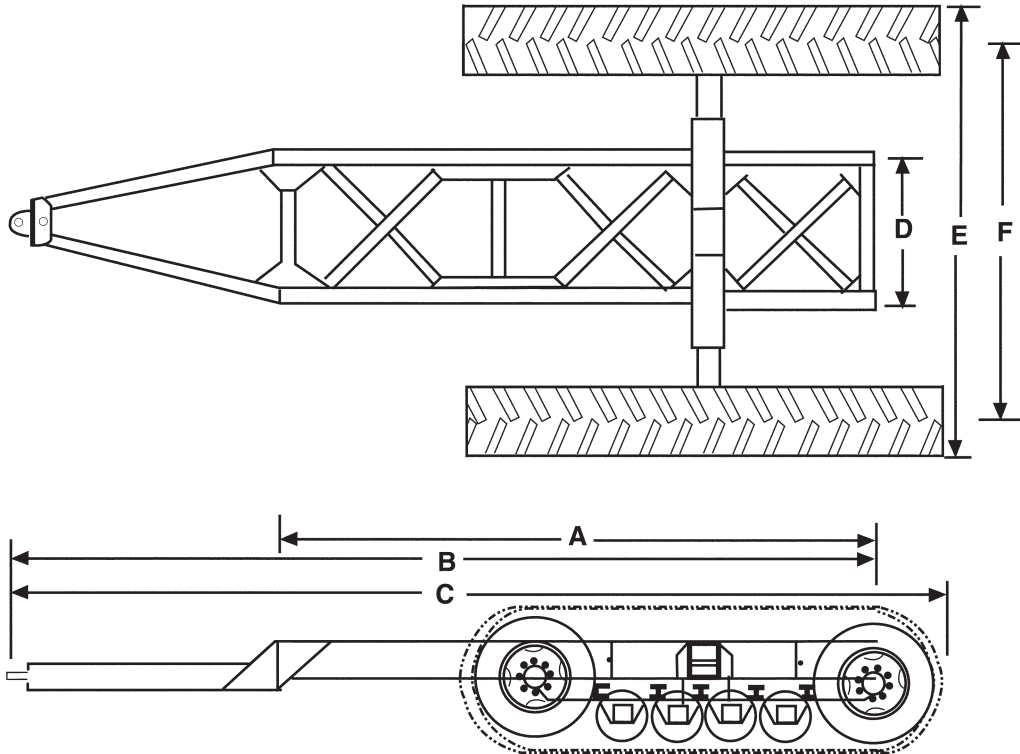

(A) Mounting Frame Length	15' 9"
(B) Frame Length	22' 4"
(C) Total Length	24' 0"
(D) Mounting Frame Width	48"
(E) Transport Width, 108" Axle Setting (24"/36" Track)	11' 0"/12' 0"
Transport Width, 120" Axle Setting (24"/36" Track)	12' 0"/13' 0"
(F) Track Center-To-Center	108" Or 120"
Frame	(Prior To SN 700021) 4" x 8" x 3/8" Wall Structural Tubing (SN 700021 And On) 4" x 12" x 1/2" Wall Structural Tubing
Estimated Shipping Weight**	(Prior To SN 700021) 11,240 Lbs. (SN 700021 And On) 11,910 Lbs.
Maximum Gross Weight	65,000 Lbs.
Track Width	24" Or 36"
Track Length	153"
Track Contact Length	108"
Track Mid Wheels	Eight 16" Steel
Track End Wheels	***Eight 8.25" x 20" Or 9" x 22.5"
Hitch	Bolt-on Single Or Double Clevis, Single Clevis Swivel Or Pintle
Parking Jack	10,000 Lb. Drop Leg
Lights	Customer-Supplied
Tractor Requirement*	As Required For Weight Load

\*  It is anticipated that modifications and attachments will be added to the Utility Tracked Chassis. KINZE Manufacturing, Inc. will not be responsible for the safety, performance or conditions created by these modifications and attachments individually or the completed machine. It is the operator's responsibility to determine adequate tractor requirement for weight load and application.

\*\* 36" track equipped machines add 1,110 lbs.

\*\*\* Smooth or treaded truck tire.

# SPECIFICATIONS

# GRAIN AUGER WAGON(W/UTC)

AL/RH294b(WGN5)

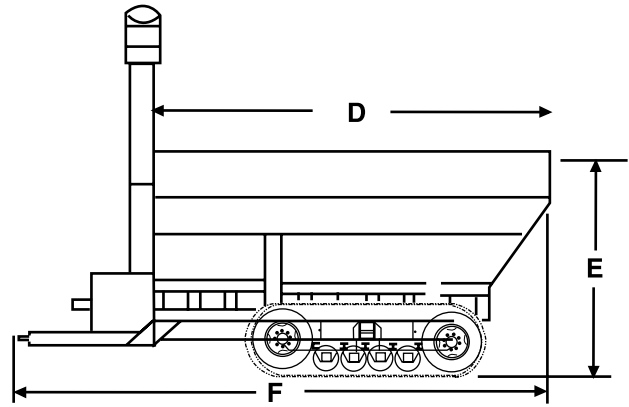
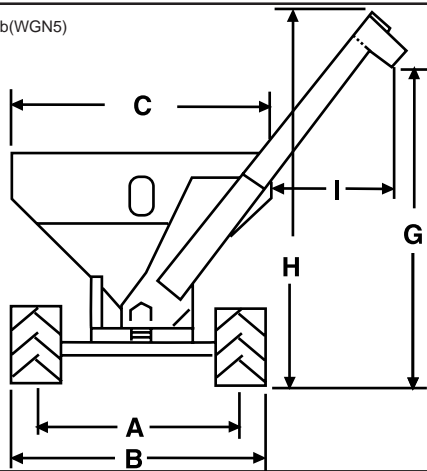

SIZES		840	1040
(A) Track Center-To-Center (Adjustable)		See UTC (Utility Tracked Chassis) Specifications	See UTC (Utility Tracked Chassis) Specifications
(B) Transport Width, 108" Axle Setting (24"/36" Track)		See UTC (Utility Tracked Chassis) Specifications	See UTC (Utility Tracked Chassis) Specifications
(B) Transport Width, 120" Axle Setting (24"/36" Track)		See UTC (Utility Tracked Chassis) Specifications	See UTC (Utility Tracked Chassis) Specifications
(C) Width - Grain Tank		10' 0"	11' 0"
(D) Length - Grain Tank		20' 0"	20' 0"
(E) Height - Grain Tank **		9' 8"	10' 8"
(F) Total Length **		27' 0"	27' 0"
(G) Height - Auger Discharge **		11' 10"	11' 10"
(H) Height - Top Of Auger **		15' 5"	15' 5"
(I) Side Of Wagon To Tip Of Spout		5' 0"	5' 0"
Wagon Weight - Empty***		19,715 Lbs.	19,865 Lbs.
Hitch Weight - Empty **		2400 Lbs.	2450 Lbs.
Hitch Weight - Loaded **		6250 Lbs.	7560 Lbs.
Total Capacity*		825 Bu.	985 Bu.
Bushels/Minute - Max.*		290 Bu./Min.	290 Bu./Min.
Vertical Auger		16" Full Pitch R.H.	16" Full Pitch R.H.
Horizontal Auger	Front	12" Full Pitch L.H.	12" Full Pitch L.H.
	Rear	12" <sup>-2</sup> / <sub>3</sub> Pitch L.H.	12" <sup>-2</sup> / <sub>3</sub> Pitch L.H.
Flighting	12"	<sup>3</sup> / <sub>8</sub> " Helicoid	<sup>3</sup> / <sub>8</sub> " Helicoid
	16"	<sup>7</sup> / <sub>16</sub> " Helicoid	<sup>7</sup> / <sub>16</sub> " Helicoid
Gearbox		A-76 Heavy Duty	A-76 Heavy Duty
Chain		Double No. 80 Roller	Double No. 80 Roller
Sprockets		Industrial Grade With Taper-Lock Bushings	
Bearings		2" - 2 <sup>7</sup> / <sub>16</sub> "	2" - 2 <sup>7</sup> / <sub>16</sub> "
PTO - 1000 RPM (U-Joint W/Shaft Shear)		160 HP Rated	160 HP Rated
PTO Yoke		1 <sup>3</sup> / <sub>8</sub> "-21 Spline Or 1 <sup>3</sup> / <sub>4</sub> "-20 Spline	
Hydraulic Flow Control		Standard	Standard
Track	Width	See UTC (Utility Tracked Chassis) Specifications	
	Length - Overall	See UTC (Utility Tracked Chassis) Specifications	
	Length - Contact	See UTC (Utility Tracked Chassis) Specifications	
	End Wheels	See UTC (Utility Tracked Chassis) Specifications	
	Mid Wheels	See UTC (Utility Tracked Chassis) Specifications	
Hitch Clevis		See UTC (Utility Tracked Chassis) Specifications	
Windows		Standard Front And Rear - All Sizes	
Chain Oiler/Lube Bank		Standard	Standard
Parking Jack		See UTC (Utility Tracked Chassis) Specifications	
Lights		Safety/Warning Lights Standard - Work Lights Optional	
Scale Option		(SN 700021 And On) Factory Or Field Installation	
Tractor Requirement (Minimum)		175 HP 2WD/4WD	225 HP 4WD

\* Approximate with 15% moisture corn. Bushels and bushels/minute will vary with moisture content of grain and/or RPM.

\*\* Weights/dimensions stated are for wagon mounted on Utility Tracked Chassis.

\*\*\* 36" track equipped machines add 1,110 lbs.

# SPECIFICATIONS











---







# SAFETY PRECAUTIONS

## GRAIN AUGER WAGON

Safe and careful operation of the tractor and auger wagon at all times will contribute significantly to the prevention of accidents.













Since a large portion of accidents occur as a result of fatigue or carelessness, safety practices should be of utmost concern. Read and understand the instructions provided in this manual and on the warning signs. Review these instructions frequently! Listed below are other safety suggestions that should become common practice.





-  At all times keep children off of and out of the auger wagon.
-  Never permit any persons other than the operator to ride on the tractor and never permit persons to ride on or in the wagon at any time.
-  Always keep hands, feet and clothing away from moving parts.
-  Do not wear loose-fitting clothing which may catch in moving parts.
-  Always wear protective clothing, substantial shoes and suitable hearing and eye sight protectors applicable for the situation.
-  Before operation, be sure there are no tools lying on or in the auger wagon.
-  Make certain tractor is in safe operating condition with adequate braking capabilities, especially when operating on uneven terrain.
-  Never operate the auger wagon without PTO driveline guards, tractor master shield and implement shields in place. Make certain PTO driveline guards turn freely and are properly attached.
-  Use a tractor equipped with a roll-over-protective-system and fasten your seat belt prior to starting the engine.
-  Do not allow anyone to stand between the tongue or hitch and the towing vehicle when backing up to the auger wagon.

-  Because of load capacities on bridges and roads and because the wagon is not equipped with brakes, the wagon is not intended for hauling loads on public roadways. It is the operator's responsibility to be aware of and follow federal, state/provincial and local regulations in this regard.
-  If the auger wagon is going to be transported on a public highway, a safety chain should be obtained and installed. Always follow federal, state/provincial and local regulations regarding a safety chain when towing farm equipment on a public highway. Only a safety chain (not an elastic or nylon/plastic tow strap) should be used to retain the connection between the towing and towed machines in the event of separation of the primary attaching system.
-  Always use adequate lights or safety warnings when transporting the wagon on public roads and after dark. Check with local law enforcement agencies for specific requirements.
-  Always make certain U-joint yokes are securely locked on tractor and implement shaft before operating wagon.
-  Be aware of bystanders, particularly children! Always look around to make sure it is safe to start the engine of the towing vehicle or move the auger wagon. This is particularly important with higher noise levels and quiet cabs, as you may not hear people shouting.
-  Be especially observant of the operating area and terrain. Watch for holes, rocks or other hidden hazards. Always inspect the area prior to operation. DO NOT operate near the edge of drop-offs or banks or on steep slopes as overturn may result. Operate up and down (not across) intermediate slopes. Avoid sudden starts and stops. Be extra careful when working on inclines.
-  Pick the levellest possible route when transporting across fields.

# SAFETY PRECAUTIONS

## GRAIN AUGER WAGON

-  Allow for unit length when making turns.
-  Never transport Row Crop wagon or load grain into Row Crop wagon with outer wheels removed.
-  Always make certain there is adequate overhead clearance before folding or unfolding the unloading auger.
-  Always fold unloading auger to down position before transporting wagon.
-  Windows give only a limited view of what is behind the wagon. Always check carefully, including blind spots, before backing or turning the wagon.
-  Limit towing speed to 15 MPH when empty and 10 MPH when loaded.
-  Always drive at a safe speed relative to local conditions and ensure your speed is low enough for an emergency stop to be safe and secure. Keep speed to a minimum.
-  Reduce speed prior to turns to avoid the risk of overturning.
-  Avoid sudden uphill turns on steep slopes.
-  Always keep the tractor in gear to provide engine braking when going downhill. Do not coast.
-  Be a safe and courteous driver. Always yield to oncoming traffic in all situations, including narrow bridges, intersections, etc.
-  Always disengage PTO, shut off tractor engine and remove the ignition key before:
  1. Leaving tractor seat.
  2. Lubricating the auger wagon.
  3. Cleaning out debris.

-  Store the auger wagon in an area away from human activity. **DO NOT** permit children to play in or around the stored unit.
-  Make sure the parked machine is on a hard, level surface. Wheel chocks may be needed to prevent unit from rolling.
-  Before applying pressure to the hydraulic system, make sure all connections are tight and that hoses and fittings have not been damaged. Hydraulic fluid escaping under pressure can have sufficient force to penetrate skin, causing injury or infection.
-  Rim and tire servicing can be dangerous. Explosive separation of tire and rim parts can cause serious injury or death. The multipiece rim used on some Sof-Trak wagons require that specific procedures and safety instructions be followed in mounting and demounting of the tires. Do not attempt to mount a tire unless you have the proper equipment and experience to perform the job. This should only be done by persons properly trained and equipped to do the job. Always maintain the correct tire pressure. Do not inflate the tires above the recommended pressure. When inflating tires, use a clip-on air chuck and extension hose long enough to allow you to stand to one side and **NOT** in front of or over the tire assembly. Use a safety cage to enclose the tire and rim assembly when inflating. Inspect tires and wheels daily. Do not operate with low pressure, cuts, bubbles, damaged rims or missing lug bolts and nuts.
-  This machine has been designed and built with your safety in mind. Do not make any alterations or changes to this machine. Any alteration to the design or construction may create safety hazards.

# SAFETY PRECAUTIONS

## GRAIN AUGER WAGON DRIVELINE

The area between the tractor and the PTO-driven implement is a DANGER zone. This can be one of the most dangerous places on your farm for you, your family and your employees.

Almost every driveline accident happens during the day and near the farmyard. Certain operating conditions are particularly dangerous:

- If your equipment is missing guards or shields.
- If you are not paying attention.
- If children are playing near where you are working.
- If you are operating a stationary piece of equipment.
- If you are wearing loose-fitting clothes.
- If you are tired or in a hurry to get finished.

Most driveline accidents happen when drivelines are operated without shields/guards or they are improperly maintained.

Heed all safety warnings in this manual and on the safety warning signs. Review these warnings frequently!



**Exercise extreme caution when operating machinery.**



**Never permit any persons other than the operator to ride on the tractor and never permit persons to ride on or in the wagon at any time.**



**At all times keep children off of and out of auger wagons. You have an obligation to keep children away. There is NO reason for any child to be near operating equipment.**



**If the elderly are assisting with farmwork, their physical limitations need to be recognized and accommodated.**



**Always keep hands, feet and clothing away from moving parts.**



**Never step across any driveline.**



**Do not attach drivelines with bolts or pins which are longer than recommended. They can not only catch loose clothing, boot-laces or a pant cuff, but while spinning rapidly, they can cause serious bodily injury.**



**Do not use the tractor drawbar, PTO or wagon tongue as a step.**



**Always disengage PTO, shut off tractor engine and remove ignition key before:**  
**1. Leaving tractor seat.**  
**2. Lubricating the auger wagon.**  
**3. Cleaning out debris.**



**Never operate the auger wagon without PTO driveline guards, tractor master shield and implement shields in place. Make certain PTO driveline guards turn freely and are properly attached.**



**Do not remove the PTO driveline guard or expose guarded parts to the driveline by cutting or enlarging the grease access holes.**



**Never operate the wagon with PTO driveline guards in a damaged condition.**



**Always make certain U-joint yokes are securely locked on tractor and implement shaft before operating wagon.**



**This machine has been designed and built with your safety in mind. Do not make any alterations or changes to this machine. Any alteration to the design or construction may create safety hazards.**

# SAFETY PRECAUTIONS

---























# SAFETY PRECAUTIONS

## UTILITY TRACKED CHASSIS

Safe and careful operation of the tractor and Utility Tracked Chassis at all times will contribute significantly to the prevention of accidents.

Since a large portion of accidents occur as a result of fatigue or carelessness, safety practices should be of utmost concern. Read and understand the instructions provided in this manual and on warning signs. Review these instructions frequently! Listed below are other safety suggestions that should become common practice.

-  At all times keep children off of the machine.
-  Never permit any persons other than the operator to ride on the tractor and never permit persons to ride on the chassis at any time.
-  Always keep hands, feet and clothing away from moving parts.
-  Do not wear loose-fitting clothing which may catch in moving parts.
-  Always wear protective clothing, substantial shoes and suitable hearing and eye sight protectors applicable for the situation.
-  Before operation, be sure there are no tools lying on the chassis.
-  Make certain tractor is in safe operating condition with adequate braking capabilities, especially when operating on uneven terrain.
-  Use a tractor equipped with a roll-over-protective-system and fasten your seat belt prior to starting the engine.
-  Do not allow anyone to stand between the tongue or hitch and the towing vehicle when backing up to the chassis.
-  Because of load capacities on bridges and roads and because the chassis is not equipped with brakes, the chassis is not intended for hauling loads on public roadways. It is the operator's responsibility to be aware of and follow federal, state/provincial and local regulations in this regard.

-  Limit maximum weight when loaded to 65,000 lbs.
-  If the chassis is going to be transported on a public highway, a safety chain should be obtained and installed. Always follow federal, state/provincial and local regulations regarding a safety chain when towing farm equipment on a public highway. Only a safety chain (not an elastic or nylon/plastic tow strap) should be used to retain the connection between the towing and towed machines in the event of separation of the primary attaching system.
-  Always use adequate lights or safety warnings when transporting the chassis on public roads and after dark. Check with local law enforcement agencies for specific requirements.
-  Be aware of bystanders, particularly children! Always look around to make sure it is safe to start the engine of the towing vehicle or move the chassis. This is particularly important with higher noise levels and quiet cabs, as you may not hear people shouting.
-  Be especially observant of the operating area and terrain. Watch for holes, rocks or other hidden hazards. Always inspect the area prior to operation. DO NOT operate near the edge of drop-offs or banks or on steep slopes as overturn may result. Operate up and down (not across) intermediate slopes. Avoid sudden starts and stops. Be extra careful when working on inclines.
-  Pick the levellest possible route when transporting across fields.
-  Allow for unit length when making turns.
-  Limit towing speed to 15 mph.
-  Always drive at a safe speed relative to local conditions and ensure your speed is low enough for an emergency stop to be safe and secure. Keep speed to a minimum.
-  Reduce speed prior to turns to avoid the risk of overturning.

# SAFETY PRECAUTIONS

## UTILITY TRACKED CHASSIS



Avoid sudden uphill turns on steep slopes.



Always keep the tractor in gear to provide engine braking when going downhill. Do not coast.



Be a safe and courteous driver. Always yield to oncoming traffic in all situations, including narrow bridges, intersections, etc.



Always disengage PTO, shut off tractor engine and remove the ignition key before:

1. Leaving tractor seat.
2. Lubricating the machine.
3. Cleaning out debris.



Make sure the parked machine is on a hard, level surface. Wheel chocks may be needed to prevent unit from rolling.



Good maintenance is your responsibility. Poor maintenance is an invitation to trouble.



Rim and tire servicing can be dangerous. Explosive separation of tire and rim parts can cause serious injury or death. The multipiece rim used on some Utility Tracked Chassis require that specific procedures and safety instructions be followed in mounting and demounting of the tires. Do not attempt to mount a tire unless you have the proper equipment and experience to perform the job. This should only be done by persons properly trained and equipped to do the job. Always maintain the correct tire pressure. Do not inflate the tires above the recommended pressure. When inflating tires, use a clip-on air chuck and extension hose long enough to allow you to stand to one side and NOT in front of or over the tire assembly. Use a safety cage to enclose the tire and rim assembly when inflating. Inspect tires and wheels daily. Do not operate with low pressure, cuts, bubbles, damaged rims or missing lug bolts and nuts.



Before applying pressure to the hydraulic system, make sure all connections are tight and that hoses and fittings have not been damaged. Hydraulic fluid escaping under pressure can have sufficient force to penetrate skin, causing injury or infection. (If Applicable)



Wide loads or loads with high center of gravity may cause instability or rollover when operating on hillside or rough terrain.



Due to the various modifications, attachments, PTO drives, hydraulic drives and/or hydraulic lifts which may be added to this chassis, KINZE Manufacturing, Inc. can not possibly anticipate, evaluate and/or advise of all possible ways in which modifications might be made or of the possible hazardous consequences of each modification. Accordingly, anyone who uses a procedure which is not recommended by KINZE must thoroughly satisfy all acceptable safety standards and himself that neither his nor the operator's safety will be jeopardized by the methods selected.



This chassis has been designed and built with your safety in mind. It is your responsibility to follow appropriate safety standards and practices to protect you and others from injury when any modifications are made or attachments are added to this chassis.

# SAFETY WARNING SIGNS

## GRAIN AUGER WAGON

The “WARNING” signs illustrated on these pages are placed on the machine to warn of hazards. The warnings found on these signs are for your personal safety and those around you. **OBSERVE THESE WARNINGS!**

- **Keep these signs clean so they can be observed readily. Wash with soap and water or cleaning solution as required.**
- **Replace “WARNING” signs should they become damaged, painted over or if they are missing.**
- **Check the reflective decals and SMV sign periodically. Replace if they show loss of any of their reflective property.**
- **When replacing decals, clean the machine surface thoroughly using soap and water or cleaning solution to remove all dirt and grease.**

**NOTE: The production date of the machine will determine style and locations of reflectors and/or reflective decals and safety warning lights to conform to ANSI/SAE S279.10 OCT 98.**

58619-21

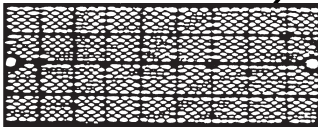

Part No. G7200-03  
Red Reflector (Qty. 4)  
(If Applicable)

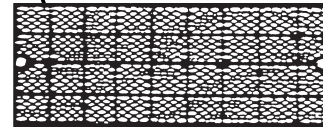

Part No. G7200-04  
Amber Reflector (Qty. 2)  
(If Applicable)

58619-48

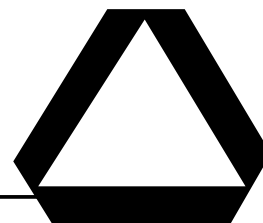
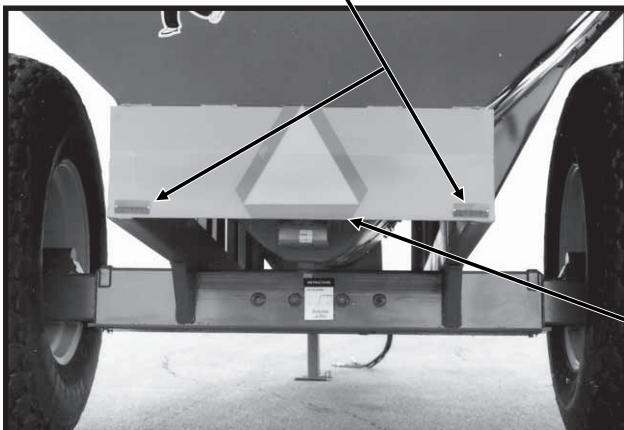

Part No. G7100-36  
SMV Sign

# SAFETY WARNING SIGNS



# GRAIN AUGER WAGON

D01230110a



**1040 Shown**



Part No. G7100-259 Amber Reflective Decal  
(640 Wagon - Qty. 8 - 4 Located On L.H. Side Of Grain Tank - 4 Located On R.H. Side Of Grain Tank)  
(840/1040 Wagons - Qty. 10 - 5 Located On L.H. Side Of Grain Tank - 5 Located On R.H. Side Of Grain Tank) (If Applicable)



Part No. G7100-259 Amber Reflective Decal  
(640 Wagon - Qty. 6 - 3 Located On L.H. Side Of Grain Tank Frame - 3 Located On R.H. Side Of Grain Tank Frame)  
(840/1040 Wagons - Qty. 8 - 4 Located On L.H. Side Of Grain Tank Frame - 4 Located On R.H. Side Of Grain Tank Frame) (If Applicable)

D01230104



**1040 Shown**



Part No. G7100-259 Amber Reflective Decal  
(Qty. 2 - 1 Located On Each Side Of The Lower Vertical Auger Housing) (If Applicable)

D0309012a

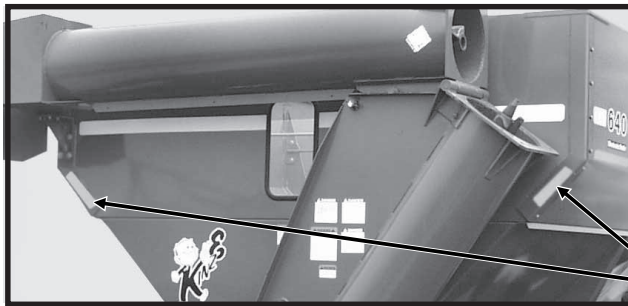

**640 Shown**



Part No. G7100-259 Amber Reflective Decal  
(Qty. 2 - Located On Front Of Grain Tank)  
(If Applicable)

D0309014a



**840 And 1040 (1040 Shown)**



D01230111a

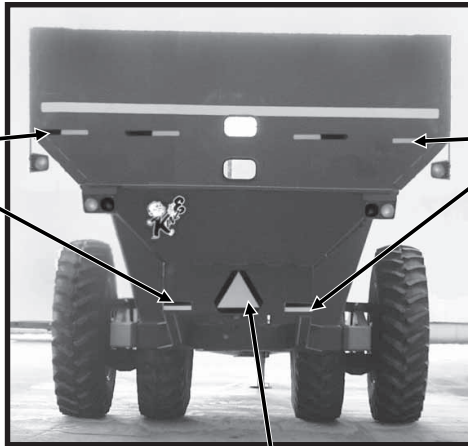

Part No. G7100-258  
Red Reflective Decal  
(Qty. 6 - Rear Facing In Transport)  
(If Applicable)



Part No. G7100-260  
Orange Reflective Decal  
(Qty. 6 - Rear Facing In Transport)  
(If Applicable)

1040 Shown

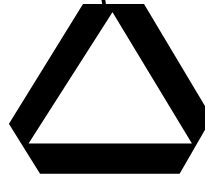

Part No. G7100-36  
SMV Sign

59577-5

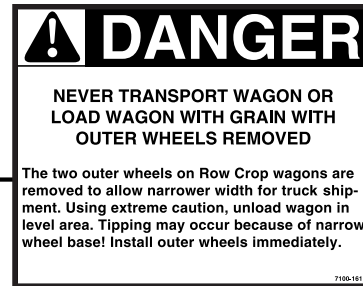
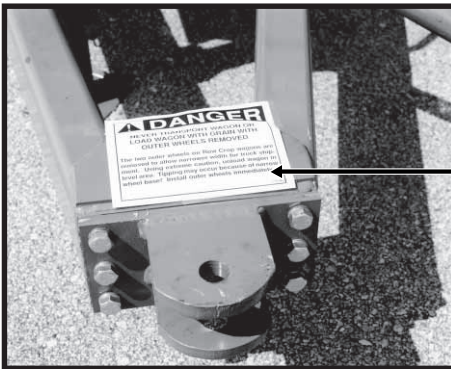

Part No. G7100-161  
Row Crop Wagon Only  
(Temporary Shipping Warning)

D01230110a



Part No. G7100-162  
Row Crop Wagon Only  
(Qty. 2 - 1 On Each Side Of Wagon)

**! WARNING !**

1. Read and understand the Operator's Manual.
2. Stop the tractor engine before leaving the operator's platform.
3. Keep riders off the machine.
4. Make certain everyone is clear of the machine before starting the tractor engine and operating.
5. Keep all shields in place.
6. Never lubricate, adjust, unplug or service the machine with tractor engine running.
7. Wait for all movement to stop before servicing.
8. Keep hands, feet and clothing away from moving parts.
9. Use flashing warning lights when operating on highways except when prohibited by law.

7100-46

Part No. G7100-46

**! DANGER !**

HYDRAULIC FOLDING AUGER

**FAILURE TO HEED THIS WARNING MAY RESULT IN PERSONAL INJURY OR DEATH.**

KEEP CLOTHING, YOURSELF AND OTHERS WELL CLEAR WHEN FOLDING AND UNFOLDING AUGER.

7100-81

Part No. G7100-81

**! DANGER !**

**SERIOUS INJURY OR DEATH CAN RESULT FROM CONTACT WITH ELECTRICAL LINES. USE CARE TO AVOID CONTACT WITH ELECTRIC LINES WHEN MOVING OR OPERATING THIS MACHINE.**

7100-117

Part No. G7100-117

**! WARNING !**

WINDOWS GIVE ONLY A LIMITED VIEW OF WHAT IS BEHIND THE WAGON. ALWAYS CHECK CAREFULLY, INCLUDING BLIND SPOTS, BEFORE BACKING OR TURNING WAGON.

7100-112

Part No. G7100-112

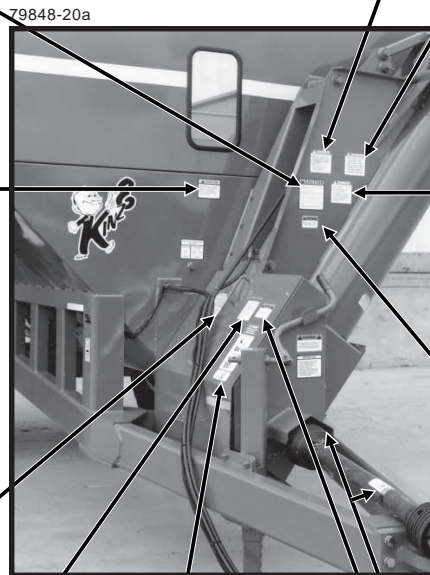

**! DANGER !**

Do Not Tow Loaded Wagons on Public Roads and Bridges. If you must tow a loaded wagon on public roads and bridges:

1. Do not exceed 10 mph.
2. Check operator's manual for the loaded weight of the wagon.
3. Tow only on roads and bridges capable of carrying the loaded weight of the wagon.
4. Know and obey all laws and regulations.

7100-120

Part No. G7100-120

**! DANGER !**

FAILURE TO HEED THESE WARNINGS MAY RESULT IN **PERSONAL INJURY OR DEATH.** NEVER ALLOW ANYONE ON OR IN WAGON WHILE OPERATING. ALWAYS UNHOOK WAGON FROM TRACTOR WHEN PERFORMING REPAIRS INSIDE OF WAGON. ALL NORMAL MAINTENANCE CAN BE PERFORMED WITHOUT CLIMBING INSIDE OF WAGON. WAGON IS INTENDED FOR FIELD USE ONLY. TOW ONLY WITH FARM TRACTOR. ALWAYS OBEY ALL LAWS AND LOAD LIMITS WHEN TRANSPORTING.

7100-82

Part No. G7100-82

**! WARNING !**

**TOW ONLY WITH FARM TRACTOR**

7100-56

Part No. G7100-56

**! WARNING !**

THIS MACHINE HAS BEEN DESIGNED AND BUILT WITH YOUR SAFETY IN MIND. DO NOT MAKE ANY ALTERATIONS OR CHANGES TO THIS MACHINE. ANY ALTERATION TO THE DESIGN OR CONSTRUCTION MAY CREATE SAFETY HAZARDS.

7100-90

Part No. G7100-90

**! DANGER !**

FLOWING GRAIN TRAPS AND SUFFOCATES VICTIM IN SECONDS!

NEVER PLAY IN OR ON THIS WAGON!



YOU CAN DIE IN SECONDS IN FLOWING GRAIN!



Farm Safety For "JUST ON'S" © 1988



7100-134

Part No. G7100-134

**! WARNING !**

NEVER OPERATE WAGON WHEN INSPECTION COVER IS REMOVED.

7100-80

Part No. G7100-80

**! DANGER !**



ROTATING DRIVELINE CONTACT CAN CAUSE DEATH KEEP AWAY!

DO NOT OPERATE WITHOUT-

- ALL DRIVELINE GUARDS, TRACTOR AND EQUIPMENT SHIELDS IN PLACE
- DRIVELINES SECURELY ATTACHED AT BOTH ENDS
- DRIVELINE GUARDS THAT TURN FREELY ON DRIVELINE

7100-67

Part No. G7100-67

D01230104

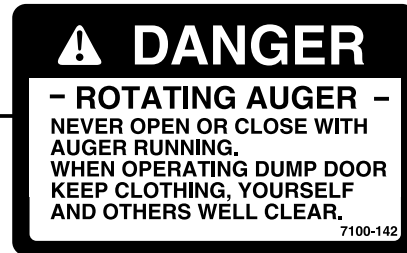

Part No. G7100-142

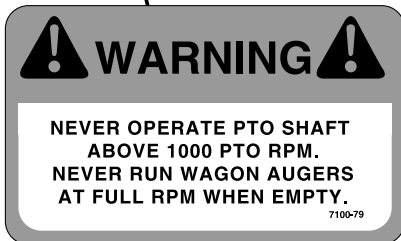

Part No. G7100-79



Part No. G7100-118

49875-20

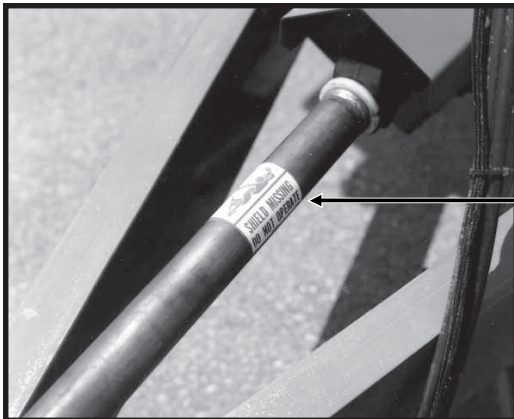

Part No. G7100-86

79848-1

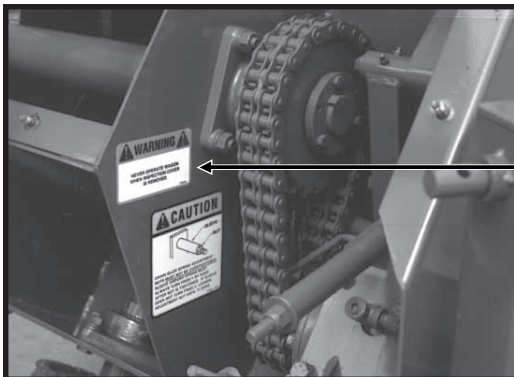

Part No. G7100-80

840 Wagon Shown

79970-5

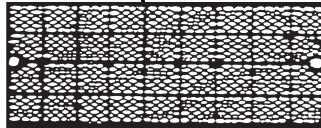
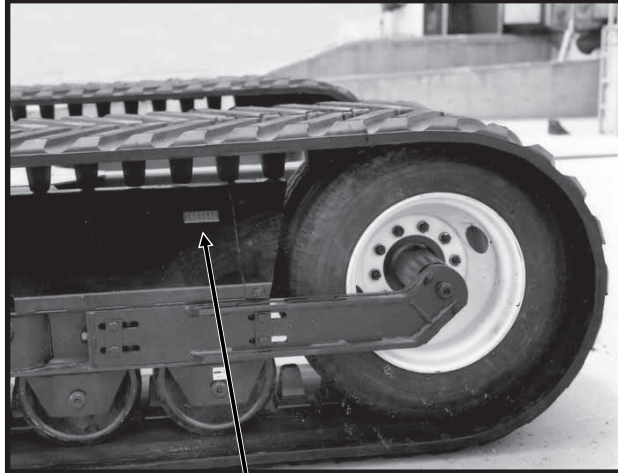

Part No. G7200-03  
Red Reflector (Qty. 6)  
(If Applicable)

Lf61-96a

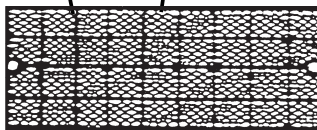
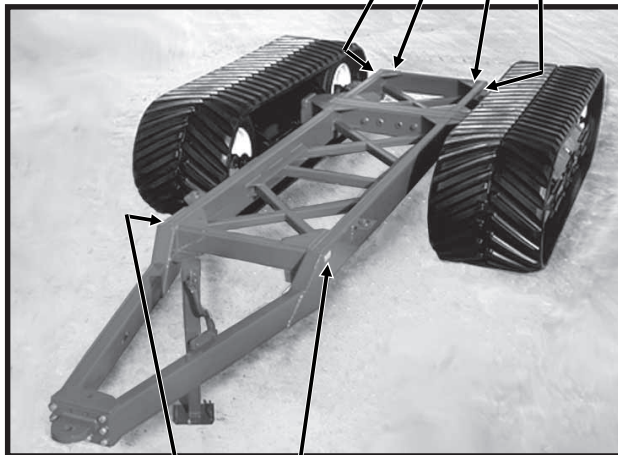

Part No. G7200-04  
Amber Reflector (Qty. 2)  
(If Applicable)





Lf61-96b

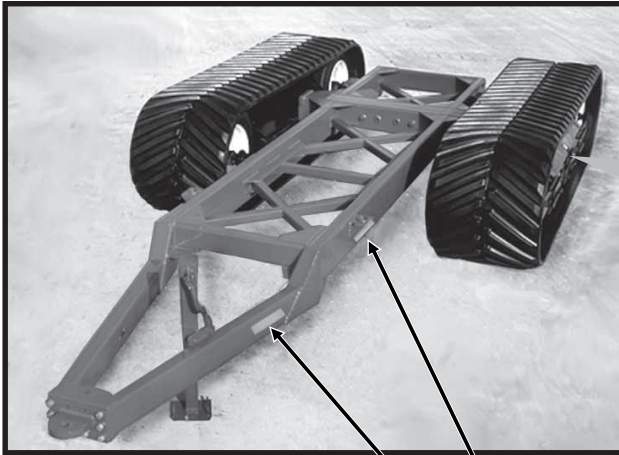

D01250103a

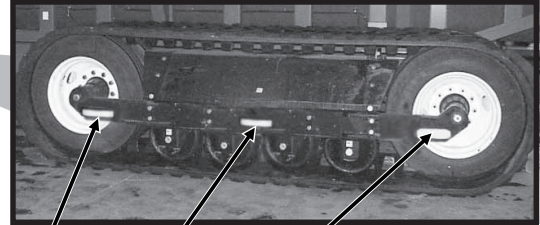

Part No. G7100-259 Amber Reflective Decal  
(Qty. 10) (If Applicable)

D01250103a

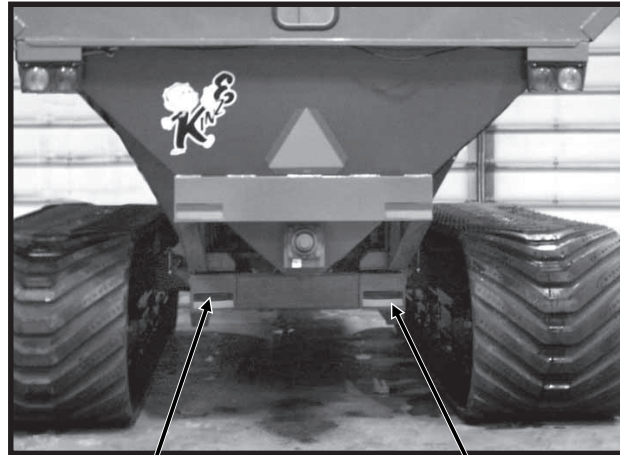

Part No. G7100-258 Red Reflective Decal  
(Qty. 2) (If Applicable)



Part No. G7100-260 Orange Reflective Decal  
(Qty. 2) (If Applicable)



79970-16



## CAUTION

1. Read and understand Utility Tracked Chassis Operator's Manual.
2. This Utility Tracked Chassis is designed for off road use only.
3. Never allow riders on or near the chassis while operating.
4. Do not exceed maximum gross vehicle weight or maximum towing speed indicated in operator's manual.
5. It is anticipated that modifications and attachments will be added to the chassis. KINZE Manufacturing, Inc. will not be responsible for the safety, performance, or conditions created by these modifications and attachments individually or the completed machine.

## WARNING

1. This chassis has been designed and built with your safety in mind. It is your responsibility to follow appropriate safety standards and practices to protect you and others from injury when any modifications are made or attachments are added to the chassis.
2. Wide loads or loads with high center of gravity may cause instability or rollover when operating on hillside or rough terrain.
3. Never leave towing vehicle's operating station without shutting off engine and applying parking brake.
4. Tow only with off road tractor of size and type to properly control gross weight and braking. If you must tow on public roads and bridges, you are responsible to be aware of and follow all appropriate federal, state and local laws and regulations in this regard.

**DO NOT REMOVE THIS DECAL.  
SHOULD DECAL BE RENDERED UNREADABLE, REPLACE IMMEDIATELY.**

7100-180

Part No. G7100-180

# LUBRICATION

The following pages show the location of all lubrication points. Proper lubrication of all moving parts will help ensure efficient operation of your KINZE® Auger Wagon and/or Utility Tracked Chassis and prolong the life of friction producing parts.

## WHEEL BEARINGS (Wheel/Row Crop Wagon)

Wheel bearings should be checked and lubricated annually.

Raise wheel off the ground and remove the dust cap. Check for endplay in the bearings by moving the tire in and out. Rotate the tire to check for roughness in the bearings. If bearings sound rough, the hub should be removed and the bearings inspected and replaced if necessary. See "Wheel Bearing Replacement" in the Maintenance Section of this manual.

If bearing replacement is not necessary, while the wheel is raised and the dust cap removed, pump grease into the hub until grease comes out through the bearing rollers. Replace dust cap.

## WHEEL BEARINGS (Sof-Trak Wagon/UTC)

Wheel bearings should be checked and lubricated annually or after every 1000 hours of use, whichever comes first.

If bearings sound rough, the hub should be removed and the bearings inspected and replaced if necessary. If bearing replacement is not necessary, pump grease into the hub until grease comes out through the seals.

See Maintenance Section of this manual if end wheel or mid wheel bearing replacement is necessary.

## DRIVE CHAINS

D01230104



The auger wagon is equipped with a one gallon capacity chain oiler system that enables you to safely and conveniently lubricate the drive chains without removing the inspection cover. A quality engine oil or equivalent SAE 30 weight oil should be used. The chains should be lubricated at least daily or more frequently if desired, particularly under extreme operating conditions.

### DRIVE CHAIN OILER OPERATION:

1. Shut off PTO and tractor engine.
2. Open brass valves located under oiler tank.
3. Start tractor engine and engage PTO at idle for a short time.



**DANGER: Remain on/in tractor while PTO is running.**

4. Disengage PTO and shut off tractor engine.
5. Close brass valves located under oiler tank.



**DANGER: Never turn oiler on or work around PTO, gearbox or chains and sprockets or allow anyone else to do so while PTO is running.**

**IMPORTANT: Extreme operating conditions such as dirt, temperature or speed may require more frequent lubrication.**



**DANGER: Never reach under the wagon to oil chains while the chains are moving. The sprockets and chains could pull you into the driveline resulting in severe injury or death!**



**DANGER: Do not operate wagon with inspection cover removed.**

# LUBRICATION

## GEARBOX OIL LEVEL

46331-8

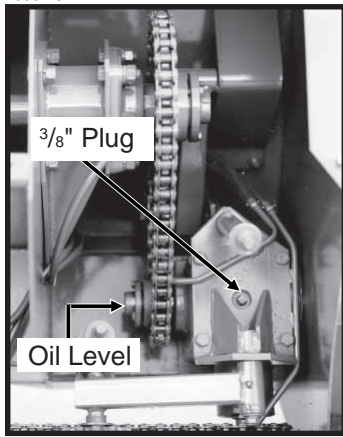

Model 640 Wagon

To check oil level, remove the  $\frac{3}{8}$ " plug. Using a clean piece of wire as a dip stick, measure the oil level to be sure it is **half way up** on the horizontal cross shaft. Fill as needed with SAE 90 weight oil. Total oil capacity is approximately 2  $\frac{1}{2}$  pints.

**NOTE: Oil level should never exceed more than half way up on the cross shaft.**

71484-2

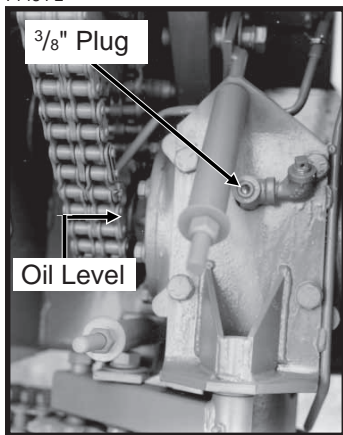

Model 840/1040 Wagons  
(Prior To Serial No. 501933)

To check oil level, remove the  $\frac{3}{8}$ " plug. Using a clean piece of wire as a dip stick, measure the oil level to be sure it is **half way up** on the horizontal cross shaft. Fill as needed with SAE 90 weight oil. Total oil capacity is approximately 5  $\frac{1}{2}$  pints.

**NOTE: Oil level should never exceed more than half way up on the cross shaft.**

71484-2

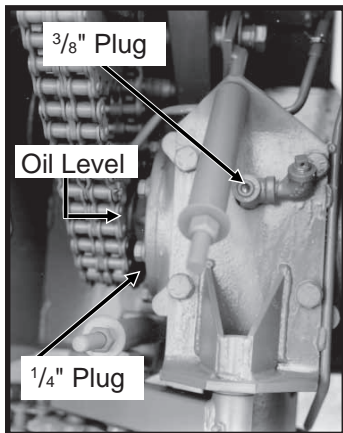

Model 840/1040 Wagons  
(Serial No. 501933 & On)

To check oil level, remove the  $\frac{1}{4}$ " plug on the L.H. side of the gearbox. If oil does not run out when the  $\frac{1}{4}$ " plug is removed, remove the  $\frac{3}{8}$ " plug on the upper side of the gearbox and add SAE 90 weight oil until it runs out of the  $\frac{1}{4}$ " hole on the L.H. side of the gearbox. Total oil capacity is approximately 5  $\frac{1}{2}$  pints.

**NOTE: Oil level should never exceed more than half way up on the cross shaft.**

## GREASE FITTINGS

Those parts equipped with grease fittings should be lubricated at the frequency indicated with an SAE multipurpose type grease. Be sure to clean the fitting thoroughly before using grease gun. The frequency of lubrication recommended on the following pages is based on normal operating conditions. Severe or unusual conditions may require more frequent attention.

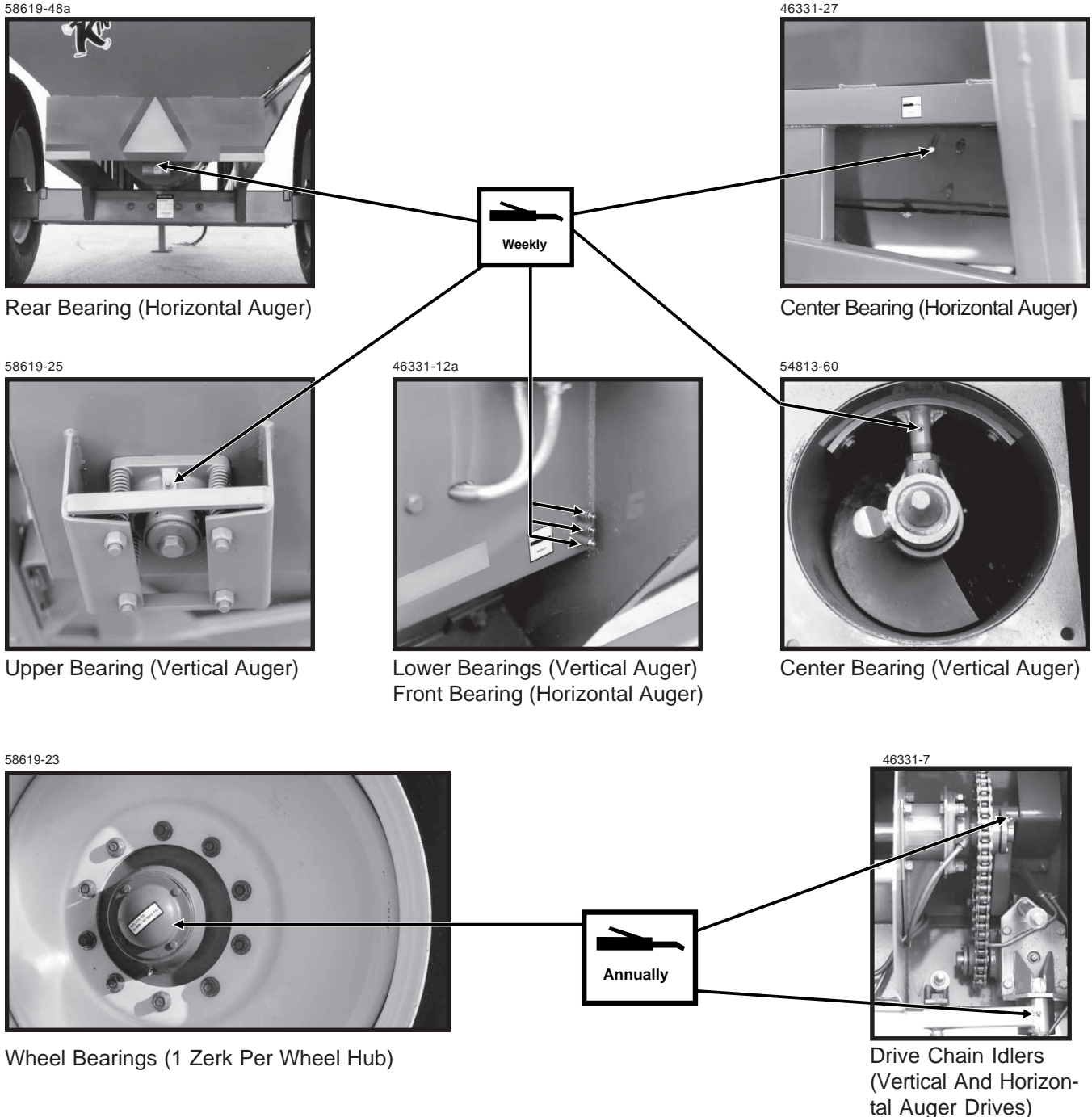

**IMPORTANT:** Extreme operating conditions such as dirt, temperature or speed may require more frequent lubrication.



46331-7

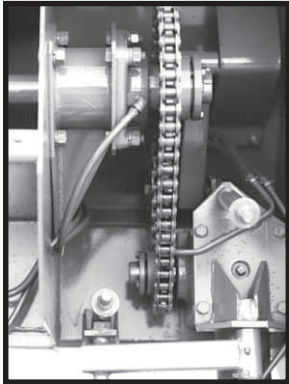

Drive Chains

D01230104

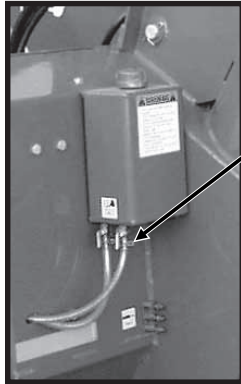

46331-34



Fold Linkage And Hinge (4 Zerks)

(WGN9/WGN10)

## STYLE A

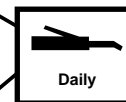
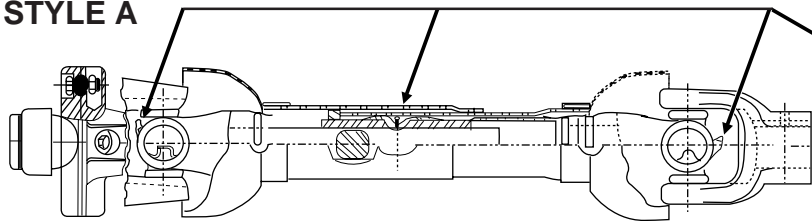

## STYLE B

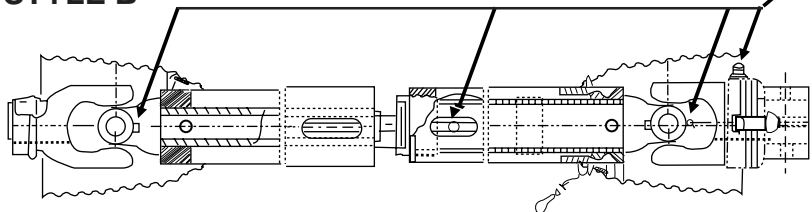

**Note: Disconnect PTO from tractor. Retract PTO assembly and rotate shield to expose grease fitting on PTO slide.**

**IMPORTANT:** Extreme operating conditions such as dirt, temperature or speed may require more frequent lubrication.

D01230111a



Rear Bearing (Horizontal Auger)

46331-27

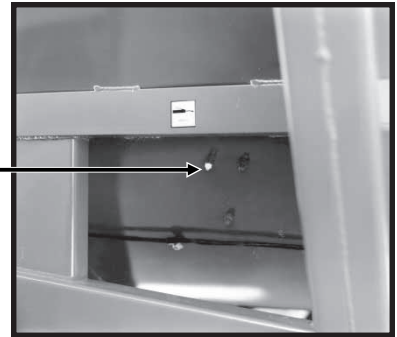

Center Bearing (Horizontal Auger)



D072099114a

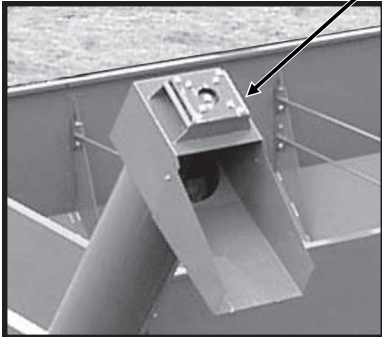

Upper Bearing (Vertical Auger)  
(Model 1040 Shown)

D01230104

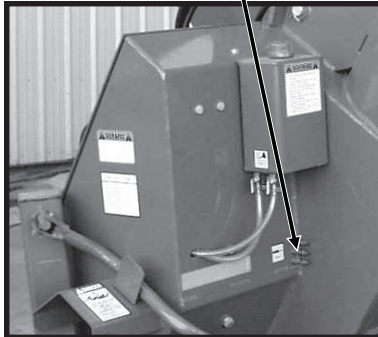

Lower Bearings (Vertical Auger)  
Front Bearing (Horizontal Auger)

54813-60

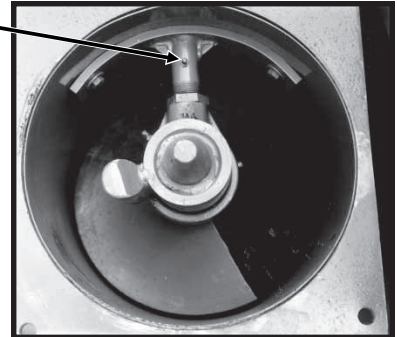

Center Bearing (Vertical Auger)

58619-23

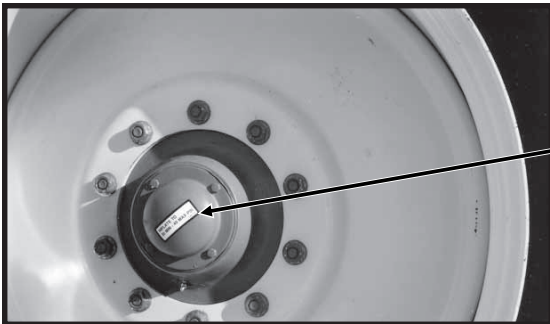

Wheel Bearings (1 Zerk Per Wheel Hub)

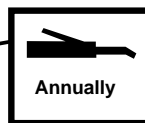

49735-14

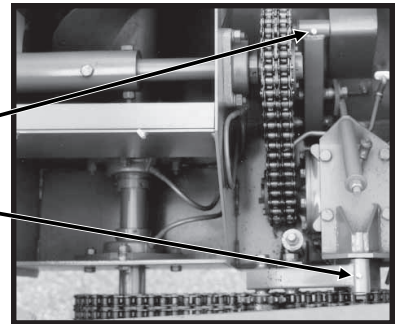

Drive Chain Idlers (Vertical And  
Horizontal Auger Drives)

**IMPORTANT:** Extreme operating conditions such as dirt, temperature or speed may require more frequent lubrication.

71484-8

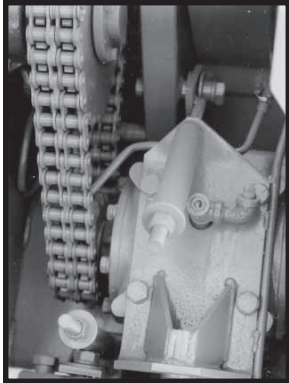

D01230104

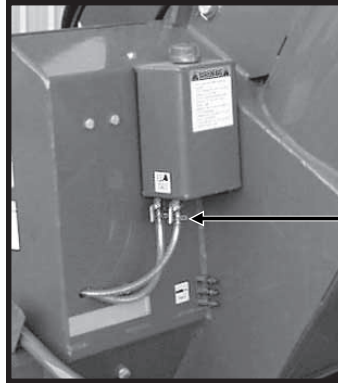

Drive Chains

58619-12

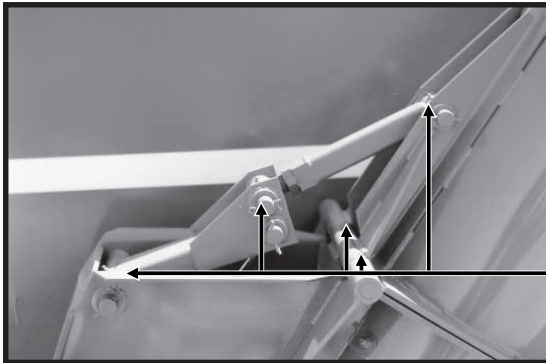

Fold Linkage And Hinge (5 Zerks)

(WGN9/WGN10)

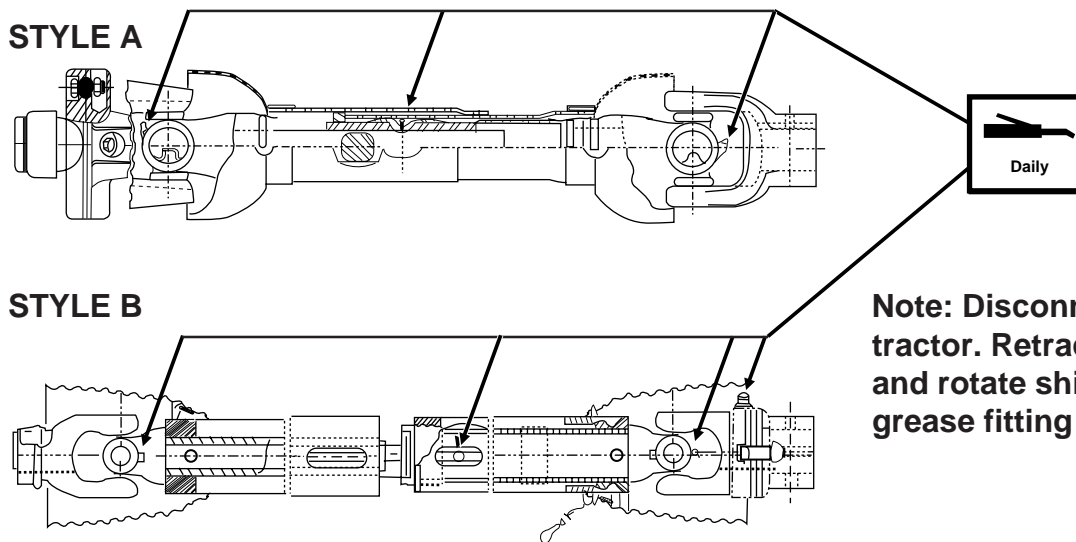

**Note: Disconnect PTO from tractor. Retract PTO assembly and rotate shield to expose grease fitting on PTO slide.**

**IMPORTANT: Extreme operating conditions such as dirt, temperature or speed may require more frequent lubrication.**



79970-4a

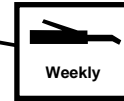
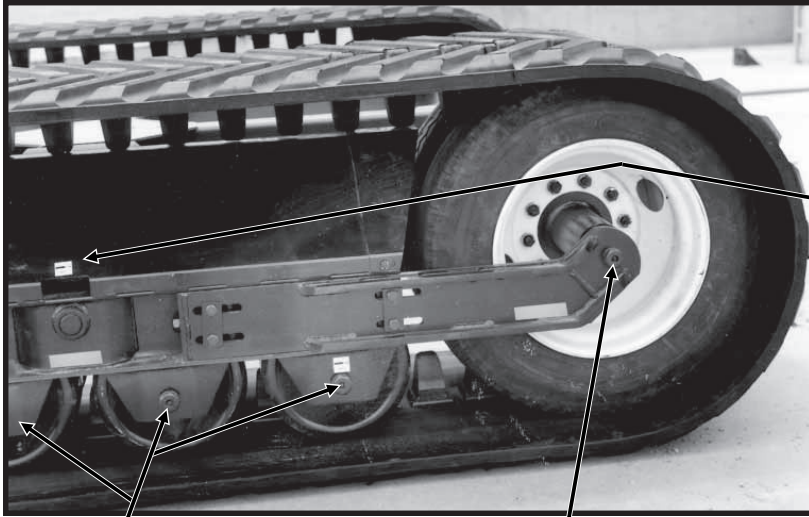

Axle  
(2 Per Side)

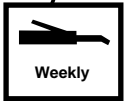

\*Mid Wheel Spindle Bolt  
(2 Per Mid Wheel Assembly)



\*End Wheel Spindle Bolt  
(2 Per End Wheel Assembly)

**\* Pump grease into hub until grease comes out around the seals.**

## STYLE A

58619-10

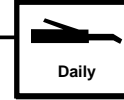

A5830(WGN74en/WGN75en)

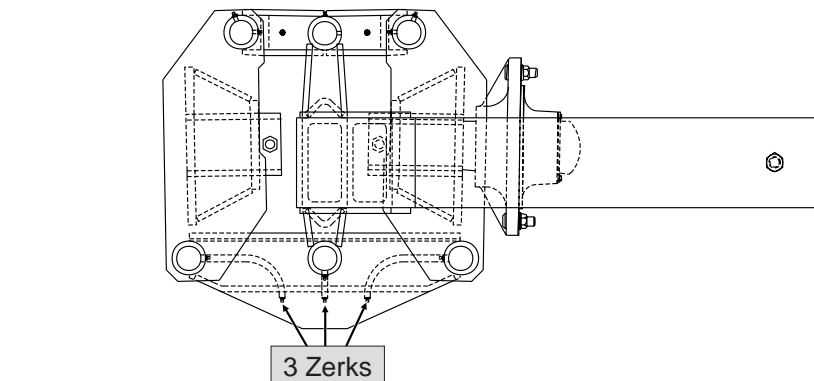
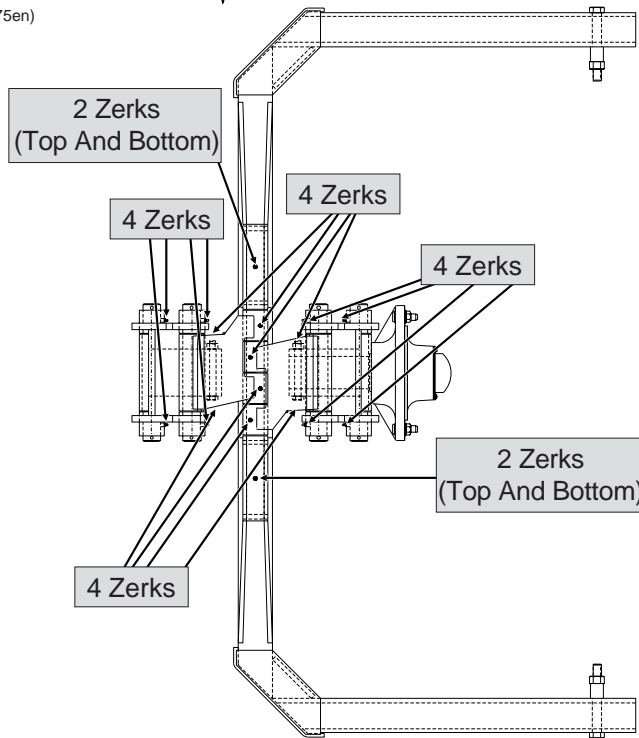

**IMPORTANT:** Extreme operating conditions such as dirt, temperature or speed may require more frequent lubrication.

## STYLE B

58619-10

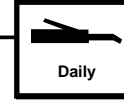
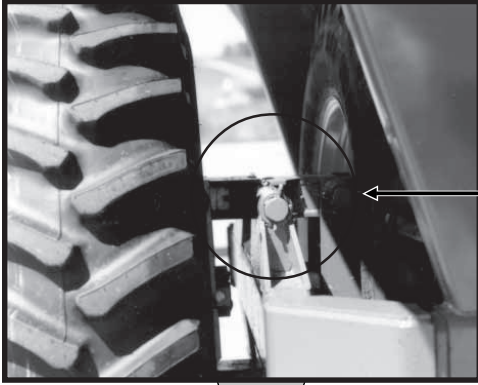

A5830(WGN74a/WGN75en)

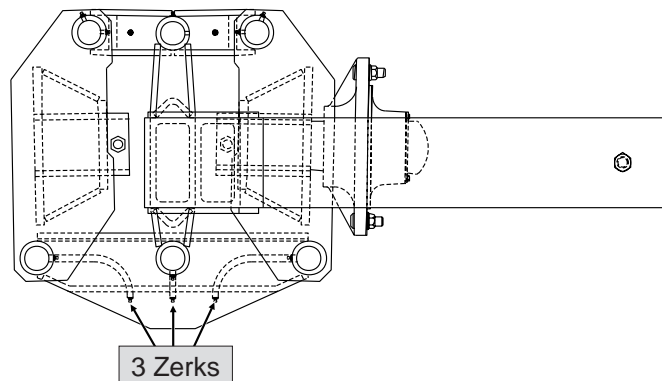
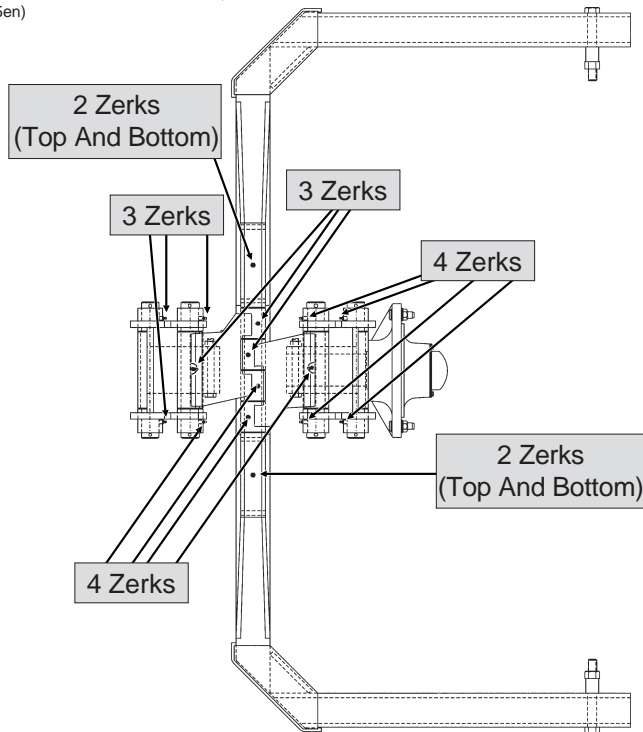

**IMPORTANT:** Extreme operating conditions such as dirt, temperature or speed may require more frequent lubrication.

# LUBRICATION

---

# OPERATION

The following information is general in nature and was written to aid the operator in preparing the tractor and auger wagon and/or Utility Tracked Chassis for use and to provide general operating procedures.

## INITIAL PREPARATION OF THE MACHINE

Lubricate the auger wagon and/or Utility Tracked Chassis per the lubrication information in this manual prior to initial operation and at prescribed intervals thereafter. Make sure all tires have been properly inflated prior to each use. Check all drive chains for proper tension, alignment and lubrication. Torque all wheel lug nuts to specified torque.

## TRACTOR PREPARATION AND HOOKUP



**WARNING: It is anticipated that modifications and attachments will be added to the Utility Tracked Chassis. KINZE Manufacturing, Inc. will not be responsible for the safety, performance or conditions created by these modifications and attachments individually or the completed machine. It is the operator's responsibility to determine adequate tractor requirement for load weight and application.**

1. Slide tractor drawbar in as far as possible and still allow PTO shaft (If Applicable) to have sufficient clearance to prevent damage to driveline components when making sharp turns and operating over uneven ground.

**IMPORTANT: If the auger wagon is attached to some tractor models with a clevis hitch (hammer-strap style) drawbar, the hammer-strap may need to be removed to prevent damage to the PTO assembly.**

(WGN117)

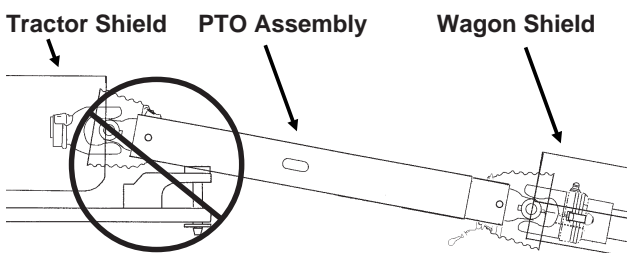

**IMPORTANT: If the auger wagon is attached to a tractor with an offset in the drawbar, be certain the offset is in the down position to prevent damage to the PTO assembly.**

(WGN116)

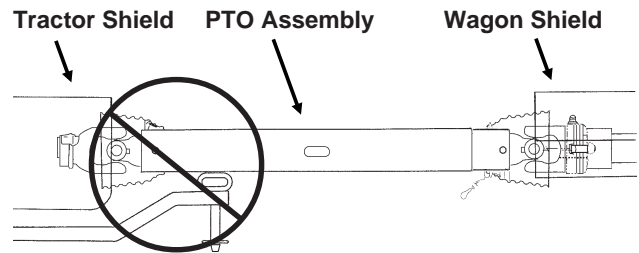

2. Connect auger wagon or Utility Tracked Chassis to tractor hitch using a high quality hitch pin of sufficient length and strength and secure pin with a locking device.

Irregardless of hitch option (single clevis, double clevis or single clevis swivel), use a high quality hitch pin of sufficient length and strength and secure pin with a locking device.

Recommended pin diameter:

Single Clevis Or .....	Pin recommended and supplied by the tractor manufacturer. (Max. 2")
Single Clevis Swivel	
Double Clevis .....	Min. 1 3/8" (Max. 1 1/2")

**NOTE: The single clevis hitch can be turned over for an additional 1 1/2" hitch height adjustment. (Recommended mounting bolt torque - 380 ft. lbs.)**

46331-94a

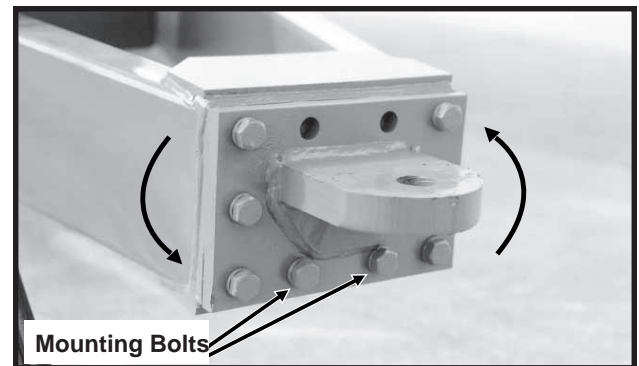

Single Clevis Hitch (Grain Auger Wagon Shown)

# OPERATION

49735-16

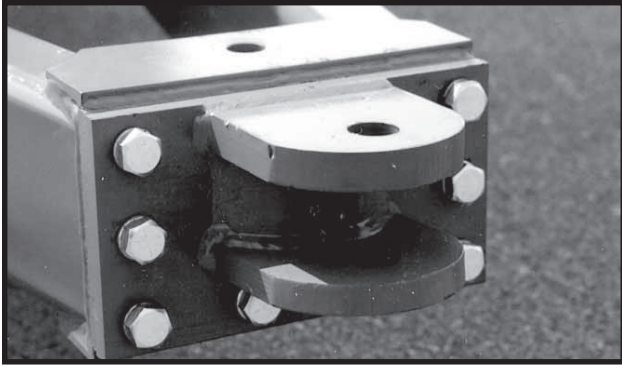

**Double Clevis Hitch (UTC Shown)**

71428-12

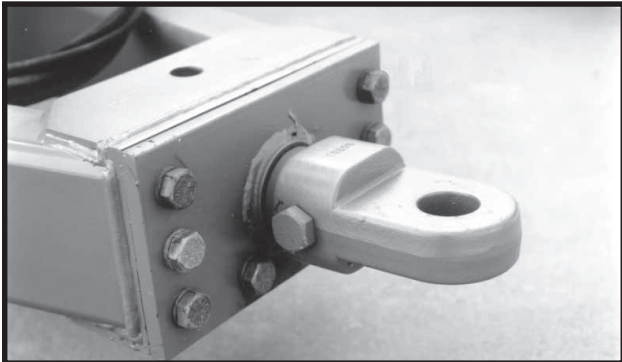

**Single Clevis Swivel Hitch (UTC Shown)**

64511-3

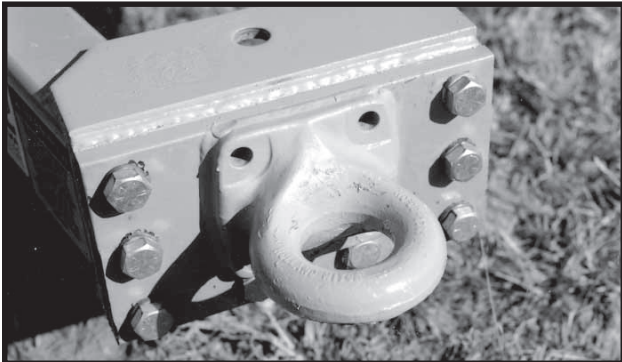

**Pintle Hitch (UTC Only)**

**NOTE:** An auxiliary attaching system (safety chain) is available from KINZE® Repair Parts through your KINZE® Dealer. Check federal, state/provincial and local regulations for requirements.

WAC010(WGN7)

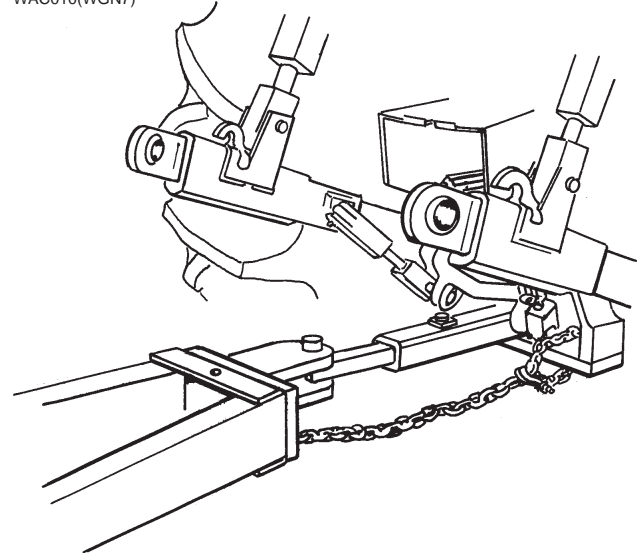

3. Attach wagon PTO connecting yoke to tractor PTO shaft. Be sure spring loaded yoke pin engages groove in tractor PTO shaft. Check that slip tube grease fitting is visible through hole of outer tube.

**IMPORTANT:** Ensure hitch height is adjusted to prevent severe bends in PTO U-joint angles and to allow sufficient clearance between tractor drawbar/hitch pin and PTO shaft.

4. Attach quick disconnect fitting to ends of hydraulic hoses to match tractor hydraulic ports. (ISO couplers standard equipment) Connect hydraulic hoses to tractor ports in a sequence which is both familiar and comfortable to the operator.



**DANGER:** Before applying pressure to the hydraulic system, make sure all connections are tight and hoses and fittings have not been damaged. Hydraulic fluid escaping under pressure can have sufficient force to penetrate skin, causing injury or infection.

**IMPORTANT:** Always wipe hose ends to remove any dirt before connecting couplers to tractor ports.

5. Raise parking jack to maximum height to prevent damage to jack in uneven operating conditions.



# OPERATION

6. Connect the seven terminal breakaway connector for the light package on the wagon to the seven pin connector on the tractor. If your tractor is not equipped with the SAE Standard 7 terminal connector, obtain through your local tractor supply dealer. Check to be sure clearance lights and signal lights are working properly.

**NOTE:** On Row Crop wagons when axle location/tire width is set for wide (36"-38") row spacing and on Sof-Trak wagons/UTC (with 36" tracks) when the tracks are set at the 120" width axle setting, the single amber light assemblies at the rear of the wagon must be relocated to the outboard side of the mounting bracket.



**DANGER:** Because of load capacities on bridges and roads and because the machine is not equipped with brakes, this machine is not intended for hauling loads on public roadways. It is the operator's responsibility to be aware of and follow federal, state/provincial and local regulations in this regard.

**IMPORTANT:** If using an auxiliary attaching system to retain the connection between the auger wagon or Utility Tracked Chassis and tractor hitch, be sure the auxiliary attaching system is of sufficient strength and length and correctly attached. Also be aware of PTO clearance.



**DANGER:** Windows give only a limited view of what is behind the wagon. The use of a rear-view mirror is recommended to aid the operator in seeing behind the wagon. Always check carefully, including blind spots, before backing or turning the wagon.

## UNLOADING THE AUGER WAGON

Unloading speed will vary with the moisture content of the grain and the PTO speed. The amount of opening on the grain flow control gate can also be used to control unloading speed.

1. After checking to see that there are no power lines or other obstacles in the way, fold the unloading auger into the unloading position. The cylinder should be fully extended and the folding linkage locked over center to lock the upper and lower auger sections in place. It is not necessary that the housing be bolted together. Check the speed at which the auger folds and if necessary adjust the tractor flow control. If the auger folds too fast it could damage the hinge assembly or force the spring loaded bearing at the upper end of the vertical auger out of adjustment.

**IMPORTANT:** The elbow in the rod end of the auger fold hydraulic cylinder is a restrictor-type elbow to control folding speed. Do not replace with any other type elbow fitting.

2. With tractor idling, engage PTO.

3. Open grain flow control gate. The amount of opening can be determined by the position of the control gate indicator on the front of the grain tank.

46331-50

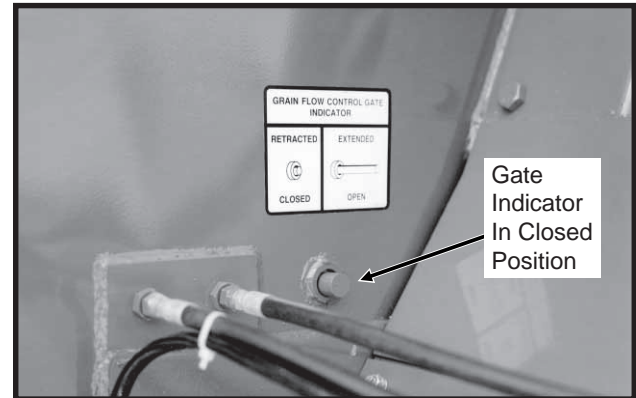

4. Increase tractor RPM to the desired speed. (Not to exceed 1000 PTO RPM.)

**IMPORTANT:** If the auger wagon is being unloaded on the move, disengage PTO before making any sharp turns.

5. As grain flow slows, reduce tractor RPM to idle.

**IMPORTANT:** Do not operate tractor PTO at full speed with the augers empty.

6. When grain flow stops, close the grain flow control gate.

7. Disengage PTO.

**NOTE:** If wagon is used around power lines, buildings, trees or other obstacles, or if the wagon is being used in rough field conditions, the unloading auger should be folded to the transport position after unloading.



**DANGER:** Care must be taken when operating wagon and/or folding unloading auger around power lines.

# OPERATION

## AUGER CLEANOUT DOOR

79989-16a



Model 640 Wagon

79848-15a



Model 840/1040 Wagons

**! DANGER: Never open cleanout door while PTO and/or augers are running.**

All models are equipped with a cleanout door that is designed primarily for clean out purposes. However, the door can be used for pit dumping.

At the end of each season or extended use, the clean out door should be removed and the auger chamber cleaned of all debris and accumulated grain to prevent rust and mold.

## Grain Pit Unloading

If the wagon is being used exclusively for pit dumping, it is important that the vertical auger drive chain be removed.

With the PTO disengaged and the tractor engine shut off, remove the clean out door. Start tractor engine and engage PTO. Regulate grain flow using grain flow control gate.

**! DANGER: Never work around PTO, gearbox or chains and sprockets or allow anyone else to do so while PTO is running.**

## DRIVELINE INSPECTION

To ensure long life and dependable service from your auger wagon, the driveline should be **inspected after approximately the first 20 loads, at the beginning of each season and after every 150 loads or annually thereafter, whichever comes first.**

Remove inspection cover and proceed as follows:

- Make a general inspection of driveline looking for loose hardware.
- Inspect chain tension. See “Auger Drive Chain Adjustment” in the Maintenance Section of this manual.
- Inspect for wear on the side of the sprockets which may indicate poor chain alignment.
- Inspect chain connectors making sure they are properly secured.
- Inspect the three cap screws in each sprocket bushing and tighten evenly to torque specifications.
- Inspect sprocket drive keys making sure they are properly located and tight.
- Inspect all grease hoses for damage and proper routing.
- Lubricate all grease fittings. See Lubrication Section of this manual.
- Inspect bearings and seals in gearbox.
- Inspect PTO attaching hardware and safety shields.
- Repair or replace worn or damaged parts.



# OPERATION

## ELECTRONIC SCALE (Wheel/Row Crop Wagon)

70723-20

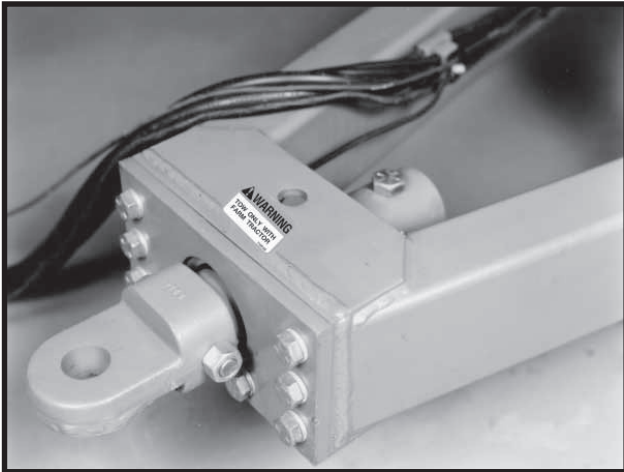

Hitch Weigh Beam

58619-30



Weigh Axle - Wheel Auger Wagon

83364-13

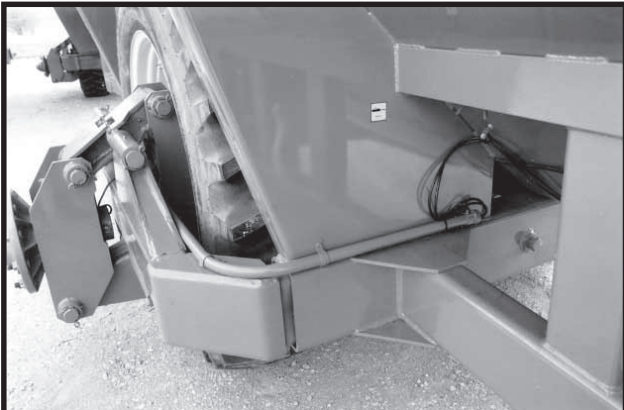

Weigh Axle - Row Crop Auger Wagon  
(Outer Wheel Removed For Visual Clarity)

An electronic scale option is available for 640 and 840 Wheel auger wagons and 840 and 1040 Row Crop wagons (Not available for Sof-Trak wagons). The electronic scale option includes two weigh axles (four on Row Crop wagons), one hitch weigh beam, a scale indicator console for tractor mounting and the required cables, brackets and hardware for mounting.

02140101



Indicator On Tractor

### Suggested Operation Procedures

**NOTE:** Movement of the wagon will cause the scale indicator reading to fluctuate.

**Step 1** Press "ON" to turn scale on.

**NOTE:** Allow 10 to 30 minutes for the scale to warm up.

**Step 2** Zero the indicator.

**Step 3** Prior to unloading the wagon, press "TARE".

**Step 4** Unload wagon. The negative reading on the scale indicator is pounds unloaded. Record weight.

**Repeat Steps 3 and 4 each time the wagon is unloaded.**

Consult scale manufacturer's manual provided and the Maintenance Section of this manual for additional information.

# OPERATION

## ELECTRONIC SCALE (Utility Tracked Chassis)

(WGN52)

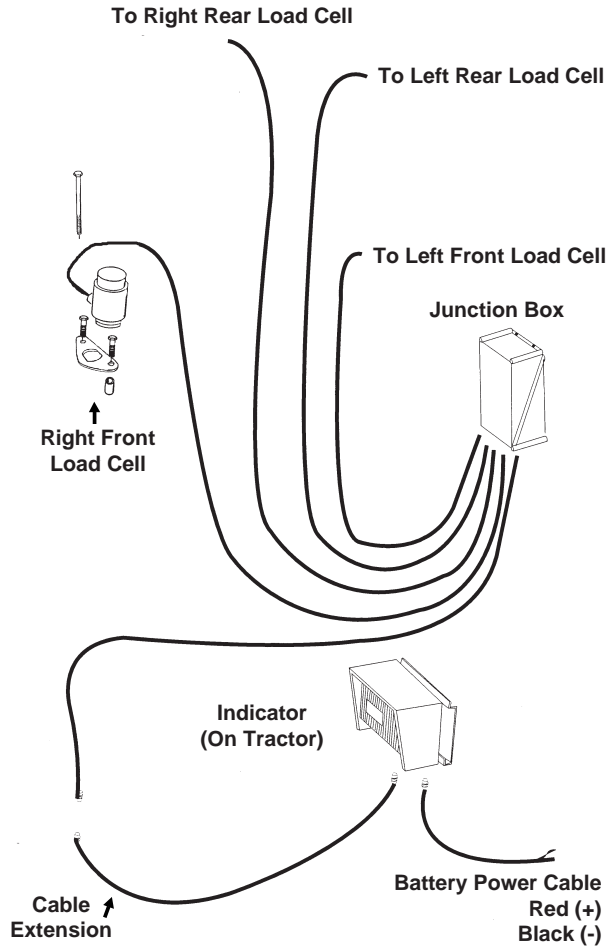

85064-18a



An electronic scale option is available for the Utility Tracked Chassis/840 and 1040 Auger Wagon. The electronic scale option includes four corner-mounted load cells, a scale indicator console for tractor mounting and the required cables, brackets and hardware for mounting.

02140101



Indicator On Tractor

### Suggested Operation Procedures

**NOTE:** Movement of the wagon will cause the scale indicator reading to fluctuate.

**Step 1** Press "ON" to turn scale on.

**NOTE:** Allow 10 to 30 minutes for the scale to warm up.

**Step 2** Zero the indicator.

**Step 3** Prior to unloading the wagon, press "TARE".

**Step 4** Unload wagon. The negative reading on the scale indicator is pounds unloaded. Record weight.

**Repeat Steps 3 and 4 each time the wagon is unloaded.**

Consult scale manufacturer's manual provided and the Maintenance Section of this manual for additional information.

# OPERATION

## ELECTRONIC SCALE PRINT OPTIONS

Two printing options are available for use with the electronic scale when the indicator console is equipped with the printer-ready feature. One option is a printer which is connected directly to the indicator console. The second option is the memory downloader kit which stores the information in the downloader module for remote printing using any Windows 95, 98, NT, Windows 3X and DOS IBM compatible PC and printer. These printing options allow recording of load information, including a load ID number (EZ210 only), time, date and weight.

### Printer Option

D11309903



Included with the printer option, in addition to the printer, is a power cable and a data cable to connect the printer to the scale indicator.

Consult the Users Manual supplied with the printer for additional information.

### Memory Downloader Option

D11309902

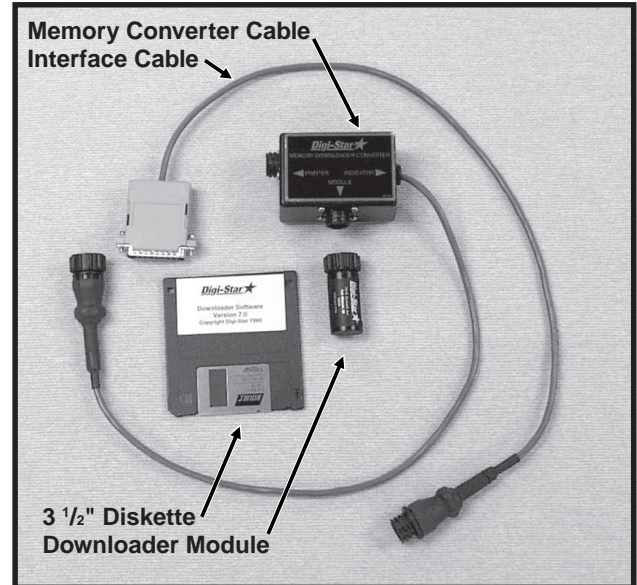

The memory downloader kit option includes the following:

1. A memory converter cable to plug into the printer port on the indicator. (The downloader module and/or a printer can be connected to the memory converter cable.)
2. An interface cable to plug into the printer port on any Windows 95, 98, NT, Windows 3X and DOS IBM compatible PC.
3. A downloader module which plugs into the memory converter cable to store information and into the interface cable to print information.
4. A 3 1/2" program diskette.

Consult the Operation & Installation Manual supplied with the downloader module for additional information.

# OPERATION

---

# MAINTENANCE

## MOUNTING BOLTS AND HARDWARE

Before operating the machine for the first time, check to be sure all hardware is tight. Check all hardware again after approximately the first 50 hours of operation and at the beginning of each season thereafter.



All hardware used on the KINZE® wagon and Utility Tracked Chassis is Grade 5 (high strength) unless otherwise noted. If hardware must be replaced, be sure to replace it with hardware of equal size, strength and thread type. Refer to the torque values chart when tightening hardware.

**IMPORTANT:** Over tightening hardware can cause as much damage as under tightening. Tightening hardware beyond the recommended range can reduce its shock load capacity.

**NOTE:** Wheel nuts should be checked weekly. Torque to 425 ft. lbs. See “Wheel Nuts” in the Maintenance Section of this manual.

TORQUE VALUES CHART - PLATED HARDWARE						
Bolt Diameter	Grade 2		Grade 5		Grade 8	
	Coarse	Fine	Coarse	Fine	Coarse	Fine
1/4"	50 In. Lbs.	56 In. Lbs.	76 In. Lbs.	87 In. Lbs.	9 Ft. Lbs.	10 Ft. Lbs.
5/16"	8 Ft. Lbs.	9 Ft. Lbs.	13 Ft. Lbs.	14 Ft. Lbs.	18 Ft. Lbs.	20 Ft. Lbs.
3/8"	15 Ft. Lbs.	17 Ft. Lbs.	23 Ft. Lbs.	26 Ft. Lbs.	33 Ft. Lbs.	37 Ft. Lbs.
7/16"	25 Ft. Lbs.	27 Ft. Lbs.	37 Ft. Lbs.	41 Ft. Lbs.	52 Ft. Lbs.	58 Ft. Lbs.
1/2"	35 Ft. Lbs.	40 Ft. Lbs.	57 Ft. Lbs.	64 Ft. Lbs.	80 Ft. Lbs.	90 Ft. Lbs.
9/16"	50 Ft. Lbs.	60 Ft. Lbs.	80 Ft. Lbs.	90 Ft. Lbs.	115 Ft. Lbs.	130 Ft. Lbs.
5/8"	70 Ft. Lbs.	80 Ft. Lbs.	110 Ft. Lbs.	125 Ft. Lbs.	160 Ft. Lbs.	180 Ft. Lbs.
3/4"	130 Ft. Lbs.	145 Ft. Lbs.	200 Ft. Lbs.	220 Ft. Lbs.	280 Ft. Lbs.	315 Ft. Lbs.
7/8"	125 Ft. Lbs.	140 Ft. Lbs.	320 Ft. Lbs.	350 Ft. Lbs.	450 Ft. Lbs.	500 Ft. Lbs.
1"	190 Ft. Lbs.	205 Ft. Lbs.	480 Ft. Lbs.	530 Ft. Lbs.	675 Ft. Lbs.	750 Ft. Lbs.
1 1/8"	265 Ft. Lbs.	300 Ft. Lbs.	600 Ft. Lbs.	670 Ft. Lbs.	960 Ft. Lbs.	1075 Ft. Lbs.
1 1/4"	375 Ft. Lbs.	415 Ft. Lbs.	840 Ft. Lbs.	930 Ft. Lbs.	1360 Ft. Lbs.	1500 Ft. Lbs.
1 3/8"	490 Ft. Lbs.	560 Ft. Lbs.	1100 Ft. Lbs.	1250 Ft. Lbs.	1780 Ft. Lbs.	2030 Ft. Lbs.
1 1/2"	650 Ft. Lbs.	730 Ft. Lbs.	1450 Ft. Lbs.	1650 Ft. Lbs.	2307 Ft. Lbs.	2670 Ft. Lbs.

**NOTE:** Unplated hardware and bolts with lock nuts should be torqued approximately 1/3 higher than the above values. Bolts lubricated prior to installation should be torqued to 70% of value shown in chart.

	<b>GRADE 2</b> No Marks		<b>GRADE 5</b> 3 Marks		<b>GRADE 8</b> 6 Marks
---	----------------------------	---	---------------------------	---	---------------------------

**For metric conversion:**    **Multiply inch pounds (In. Lbs.) by .113 to convert to newtons-meters (N•m).**  
**Multiply foot pounds (Ft. Lbs.) by 1.356 to convert to newtons-meters (N•m).**



# MAINTENANCE

## AUGER DRIVE CHAIN ADJUSTMENT

To prevent excessive wear on the auger drive chains and sprockets, the chains must be maintained and properly tensioned.

Adjust horizontal auger chain tension and vertical auger chain tension as follows:

71484-1

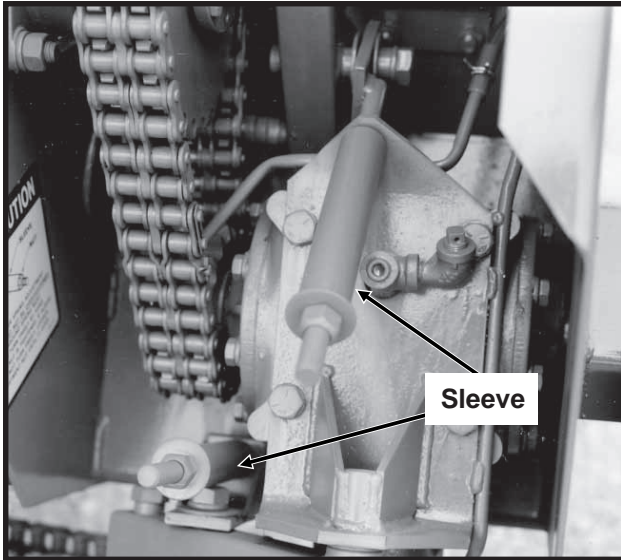

Shown With Inspection Cover Removed



**DANGER: Never run chains with inspection cover removed.**

1. Tighten  $\frac{5}{8}$ " lock nut until spring housing sleeve bottoms out. There should be no gap between the nut and the sleeve and no endplay on the sleeve.
2. Back off lock nut until spring housing sleeve can be rotated by hand with slight resistance.

(WGN11)

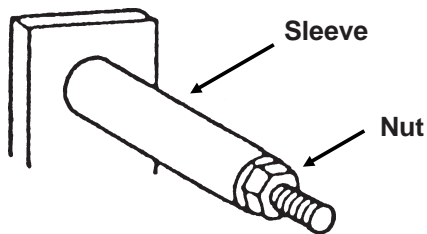

**NOTE: The auger drive chains should be adjusted to establish a deflection of  $\frac{1}{4}$ " to  $\frac{3}{8}$ " with 20 lbs. of force on the span opposite the idler sprockets.**

## VERTICAL AUGER FOLD

The vertical auger fold is preset at the factory and should require no additional adjustment. However, if the auger housing or cylinder is replaced, adjustment may be necessary.

When properly adjusted, the folding linkage should "snap" over-center at the end of the extended stroke of the cylinder. This over-center action holds the unloading auger in position without the need for hydraulic pressure from the cylinder.



**DANGER: Stand clear when folding auger.**

To adjust the folding linkage, loosen jam nut, remove pin from one end of linkage arm and rotate the arm in or out as required.

58619-12

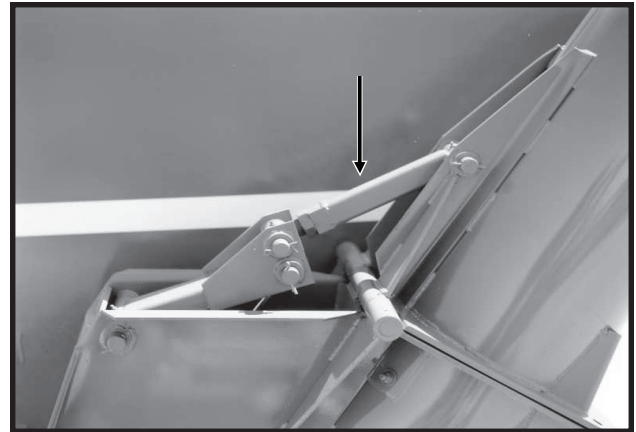

If the linkage arm is adjusted, the auger housing stop bracket (located on the grain tank and used when the auger is folded for transport) will need to be adjusted.

D01230106a

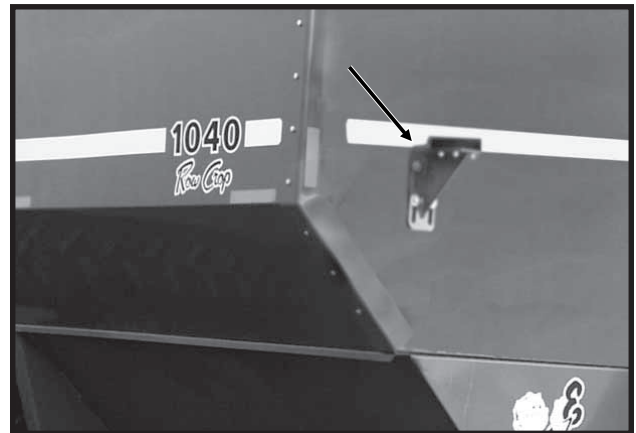

# MAINTENANCE

## WIRING DIAGRAM

(WGN66)

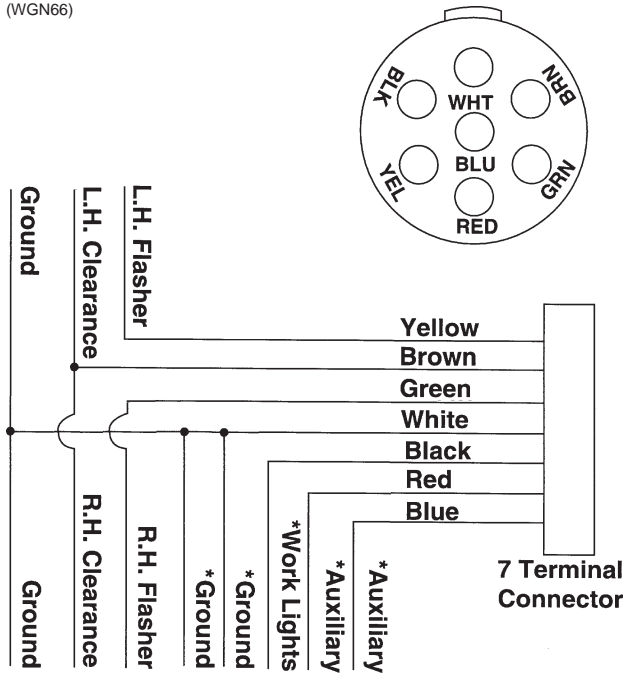

\*Optional auxiliary work lights are available from KINZE® which may be wired into existing auxiliary and work light wires in the harness.

Light package supplied on the grain auger wagon meets ASAE standards. For the correct wiring harness to be wired into the lights on your tractor, check with the tractor manufacturer.

69922-35



## PTO SHEAR BOLT PROTECTION

To ensure driveline and gearbox protection, all KINZE® auger wagons are equipped with a shear bolt yoke in the PTO shaft. Should the auger become obstructed, the yoke is designed to shear the connecting bolt before further damage can occur.

**NOTE:** Always use identical quantity, size and grade of bolt for replacement.

**Style A** - Shear is located in tractor half of PTO assembly and is accessible from end of PTO shield. One  $\frac{3}{8}$ "-16 x 1" Grade 5 cap screw and lock nut are used.

(WGN9)

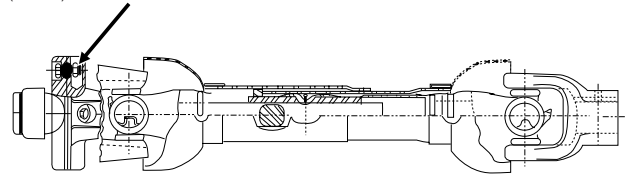

**Style B** - Shear is located in wagon half of PTO assembly. One  $\frac{3}{8}$ "-16 x 2  $\frac{1}{2}$ " Grade 5 cap screw (10mm diameter Grade 8.8 metric) and lock nut is used on 840/1040 wagons. One  $\frac{5}{16}$ "-18 x 2  $\frac{1}{2}$ " Grade 5 cap screw (8mm diameter Grade 8.8 metric) and lock nut is used on the 640 wagon.

(WGN10)

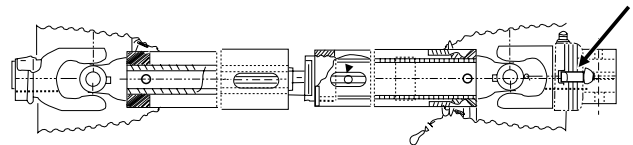



# MAINTENANCE

## WHEEL NUTS

The wheels are attached to the hubs with press fit bolts through the hub flanges and wheel nuts. Upon any removal and installation of the wheel, clean threads with a wire brush and oil lightly to retard corrosion.

### TORQUE PROCEDURE:

Torque wheel nuts to 425 ft. lbs. and retorque periodically thereafter as follows:

- a. After 4 hours use.
- b. After 16 hours use.
- c. Weekly during season.

**NOTE:** On machines equipped with cast iron segmented end wheels, torque the hardware which attaches the segments to the hub to 220 ft. lbs. Follow the torque procedure above.

## TIRE PRESSURE

Tire pressure should be checked prior to each use of the machine. Maintain tire pressures as follows:

	Minimum/Maximum
18.4" x 38" .....	35 PSI/40 PSI
24.5" x 32" .....	35 PSI/40 PSI
30.5" x 32" .....	35 PSI/40 PSI
*8.25" x 20"; Sof-Trak Wagon/UTC (Smooth) .....	*55 PSI
*8.25" x 20"; Sof-Trak Wagon/UTC (Treaded) .....	*85 PSI
*9" x 22.5"; Sof-Trak Wagon/UTC .....	*85 PSI

\*All tire pressures must be equal.



**DANGER:** Rim and tire servicing can be dangerous. Explosive separation of tire and rim parts can cause serious injury or death.

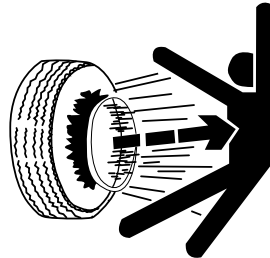

The multipiece rims used on some Sof-Trak wagons and Utility Tracked Chassis require that specific procedures and safety instructions be followed in mounting and demounting of

the tires. Do not attempt to mount a tire unless you have the proper equipment and experience to perform the job. This should only be done by persons properly trained and equipped to do the job. Always maintain the correct tire pressure. Do not inflate the tires above the recommended pressure. When inflating tires, use a clip-on air chuck and extension hose long enough to allow you to stand to one side and NOT in front of or over the tire assembly. Use a safety cage to enclose the tire and rim assembly when inflating. Inspect tires and wheels daily. Do not operate with low pressure, cuts, bubbles, damaged rims or missing wheel bolts and nuts.

# MAINTENANCE

## AUGER TIMING

If vertical augers or the drive bullet assembly have been removed for any reason, special care must be taken to reinstall the bullet assembly in the proper position. It is possible to install the bullet assembly in two positions 180° apart. One position will place the auger assembly out of time and restrict the flow of grain between the upper and lower auger. The proper location is noted in the photos below. **A properly installed bullet assembly places the drive pin where it is closest to the flighting on the auger when measuring down the drive pin to the flighting on the auger.**

58619-39/54813-41/54813-38

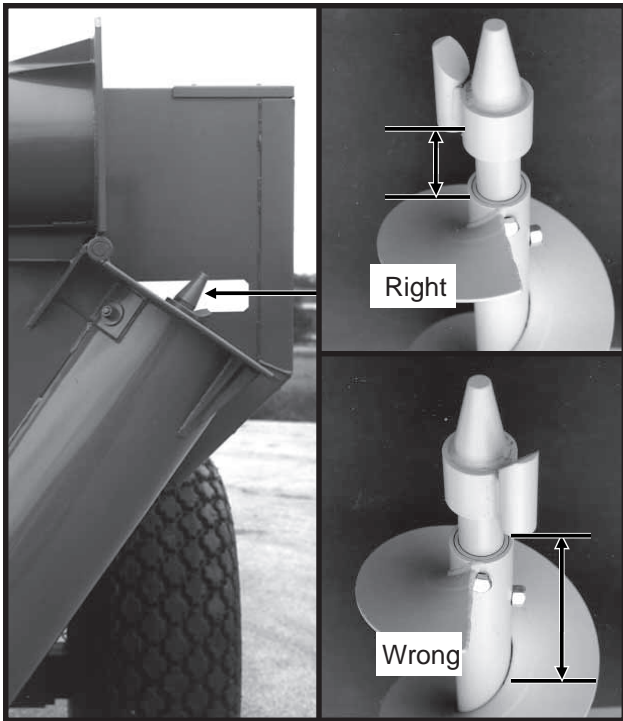

## MUD SCRAPER ADJUSTMENT

(Sof-Trak Wagon/UTC - Rubber-Tire End Wheels Only)

79970-26a

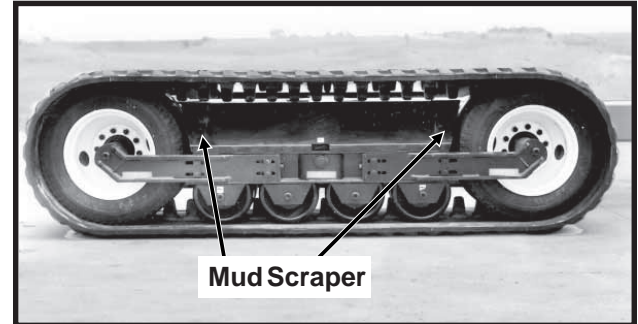

Slotted attachment holes on the scrapers allow for scraper adjustment. Each scraper should be adjusted to maintain 1/2" clearance between the scraper and tires.

## TRACK TENSION (Sof-Trak Wagon/UTC)

79970-4a

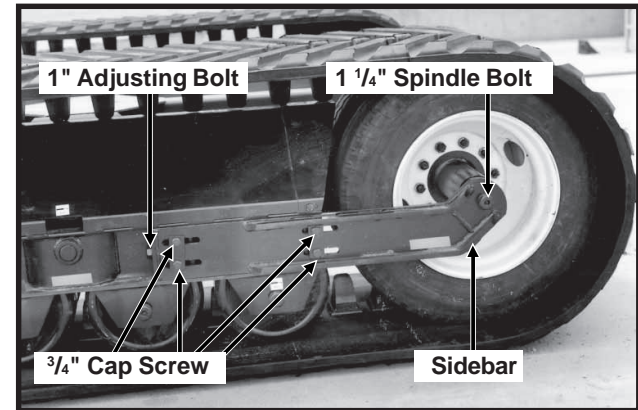

Rubber-Tire End Wheels Shown

There should be approximately 3/4" to 1" of sag (rubber-tire end wheels) or 1" to 2" sag (cast iron end wheels) in the track at the midpoint between the front and rear end wheels. To check for proper tension, lay a straight edge across the complete length of the track. Measure the distance between the track and the straight edge at the midpoint. **NOTE: The centering lugs, on 36" tracks, may lightly touch the top center of the track chassis.**

If adjustment is needed, loosen the four 3/4" attachment cap screws on the inside sidebar and the four 3/4" attachment cap screws on the outside sidebar on one end (front or rear) of the track assembly. Turn the 1" adjusting bolt on the end of each sidebar in or out equal amounts according to the adjustment needed. Retighten the four 3/4" cap screws on each sidebar. Torque to 220 ft. lbs. For additional adjustment it may be necessary to repeat the above procedure on the opposite end of the track assembly.

# MAINTENANCE

## TRACK ALIGNMENT (Sof-Trak Wagon/UTC)

RH490(WGN15)

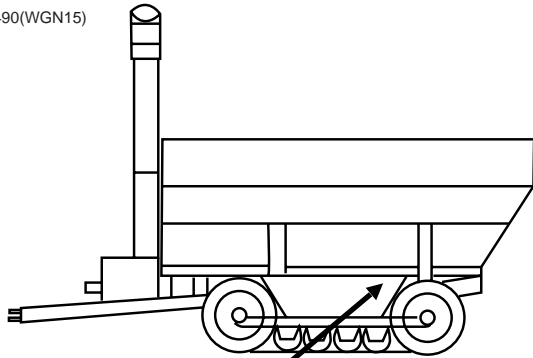

RH050390(WGN16)

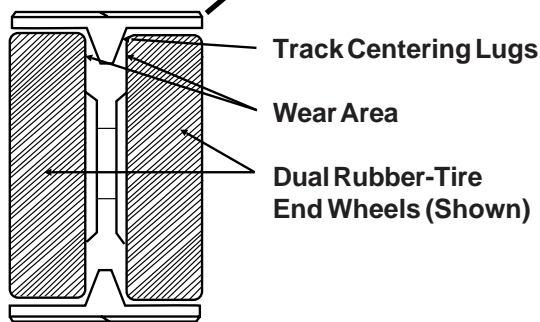

When properly aligned, the track centering lugs should run centered between the dual end wheels as the lugs enter the end wheels when the tracks are rotated. Proper track alignment is important and should be **checked daily** to ensure maximum life of the end wheels and tracks.

### Rubber-Tire End Wheels

Misalignment will cause heat build up and scuffing of the rubber on the inside of the tires. To check alignment, drive empty wagon 4-5 miles. Stop. Feel for heat buildup on sidewalls of end wheel tires.

**NOTE: Equal tire pressure is important to maintain proper track alignment. See "Tire Pressure".**

### Cast Iron End Wheels

Misalignment will cause heat build up on the mid wheels and end wheels. To check alignment, drive empty wagon 1 mile at 8 to 10 MPH. Stop. Feel for heat buildup on mid wheels and end wheels.

Alignment adjustment is made by loosening the four  $\frac{3}{4}$ " cap screws on each sidebar and extending or retracting the sidebar(s) until proper alignment is obtained. Extending the sidebar (turning 1" adjusting bolt clockwise) closest to the end wheel showing evidence of misalignment or retracting the sidebar (turning the 1" adjusting bolt counterclockwise) on the end wheel on the opposite side will move the centering lugs away from the end wheel. Retighten the four  $\frac{3}{4}$ " cap screws on each sidebar. Torque to 220 ft. lbs.

## TIRE REPAIR (Sof-Trak Wagon/UTC - Rubber-Tire End Wheels Only)

To remove a tire for repair, position a jack at the axle and raise the side of the machine. Remove mud scraper.

Mark the position of both the inside and outside sidebars nearest the tire being removed. Loosen the four  $\frac{3}{4}$ " cap screws and 1  $\frac{1}{4}$ " spindle bolt on each sidebar. Loosen the 1" adjusting bolt on each sidebar. Remove the sidebar on the side next to the tire being repaired. Remove wheel nuts and remove tire.

After the tire has been reinstalled and the wheel nuts torqued to 425 ft. lbs., reinstall the sidebar. Extend sidebars to the previously marked positions and tighten all hardware. Torque  $\frac{3}{4}$ " cap screws to 220 ft. lbs. and 1  $\frac{1}{4}$ " spindle bolt to 1360 ft. lbs. Replace mud scraper. Check track alignment, track tension and mud scraper clearance. Adjust if necessary.

**NOTE: Retorque wheel nuts as follows:**

- a. After 4 hours use.
- b. After 16 hours use.
- c. Weekly during season.



**DANGER: Rim and tire servicing can be dangerous. Explosive separation of tire and rim parts can cause serious injury or death.**

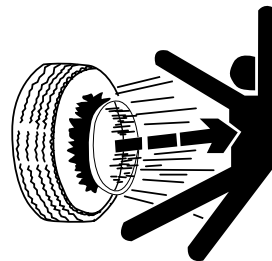

The multipiece rims used on some Sof-Trak wagons and Utility Tracked Chassis require that specific procedures and safety instructions be followed in mounting and demounting of

the tires. Do not attempt to mount a tire unless you have the proper equipment and experience to perform the job. This should only be done by persons properly trained and equipped to do the job. Always maintain the correct tire pressure. Do not inflate the tires above the recommended pressure. When inflating tires, use a clip-on air chuck and extension hose long enough to allow you to stand to one side and **NOT** in front of or over the tire assembly. Use a safety cage to enclose the tire and rim assembly when inflating. Inspect tires and wheels daily. Do not operate with low pressure, cuts, bubbles, damaged rims or missing wheel bolts and nuts.

# MAINTENANCE

## INSIDE TIRE REPAIR OR REMOVAL (Row Crop Wagon)

In order to repair or remove the inside tire on the Row Crop wagon, the complete tire/axle assembly on that side of the wagon must be removed.

**IMPORTANT: If there is grain in the wagon, it must be unloaded.**

Make sure the wagon is on level ground that is firm enough to support the weight of the wagon while the wagon is raised. Hitch the wagon to a tractor to stabilize the wagon fore and aft.

Remove the two 1" x 8" cap screws and sleeves on the center axles. Place a hydraulic jack under the wagon frame just ahead of the tire/axle assembly and raise the wagon until weight is removed from the assembly. Place blocking under the wagon at the front axle/frame to support the wagon and lower the jack until the frame is supported by the blocking. There will be some side pressure on the wagon when the tire/axle assembly is being removed and reinstalled. Therefore, the blocking must be placed in such a way as to give a wide base of support as shown below.

HTA037(WGN56)

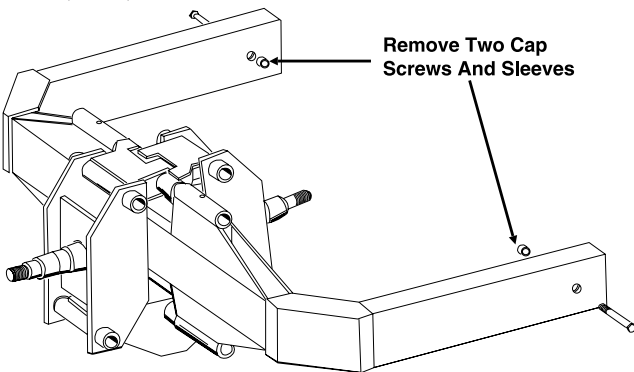

59536-13



To remove the tire/axle assembly, attach a chain around the top pivot pin and using a forklift or loader, raise the tire/axle assembly slightly and slowly back up. If the assembly won't slide out, move it up and down to free it.

59536-6a



**IMPORTANT: Care must be taken to prevent pulling or pushing the wagon off the support blocking while removing and installing the assembly.**



**DANGER: Never work around or under the wagon with the tire/axle assembly removed.**

Remove wheel nuts and remove tire from hub.



**DANGER: Rim and tire servicing can be dangerous. Explosive separation of tire and rim parts can cause serious injury or death.**

After tire repair is completed, reinstall tire onto hub and torque wheel nuts to 425 ft. lbs.

**NOTE: Be sure tire is reinstalled with the offset in the rim to the same side as previously installed.**

Reposition tire/axle assembly under wagon at desired axle adjustment. Install the two 1" x 8" cap screws and sleeves and torque to 480 ft. lbs.

**NOTE: Retorque wheel nuts as follows:**

- After 4 hours use.
- After 16 hours use.
- Weekly during season.



**DANGER: Never transport Row Crop wagon or load Row Crop wagon with grain with outer wheels removed.**



# MAINTENANCE

## AXLE ADJUSTMENT (Row Crop Wagon)

The tire width on Row Crop wagons can be set for 30" row spacing or wide (36" - 38") row spacing. Row spacing is determined by axle adjustment and tire rim position.



**DANGER: Never transport Row Crop wagon or load Row Crop wagon with grain with outer wheels removed.**

Row Crop wagons are shipped with the outer wheel and hub assembly on each side of the wagon removed and the axle and inner wheel rims installed for 30" row spacing. For field operation with 30" row spacing, install the outer wheel assembly onto each side of the wagon with the offset in the rim to the outside as shown at right. Torque wheel nuts to 425 ft. lbs.

If wide (36" - 38") row spacing is desired, remove the two 1" x 8" cap screws, two sleeves and complete tire/axle assembly. Reverse the inner wheel so the offset in the rim is to the outside of the wagon as shown below. Follow the procedure described in "Inside Tire Repair Or Removal" for raising the wagon and removing the inside tire. Reposition tire/axle assembly approximately 12" outward from the 30" row spacing location. See illustration in next column. Torque 1" bolts to 480 ft. lbs. Install outer wheels with offset in rim to the inside. Torque wheel nuts to 425 ft. lbs. Repeat procedure on opposite side of wagon.

HTA037(WGN56)

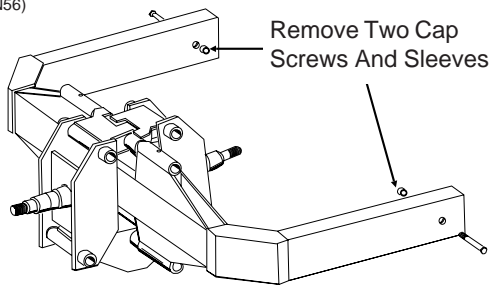

**NOTE: Below illustrations viewed from rear of wagon. Offset in rim is exaggerated to show positioning.**

RH050490(WGN17/WGN57)

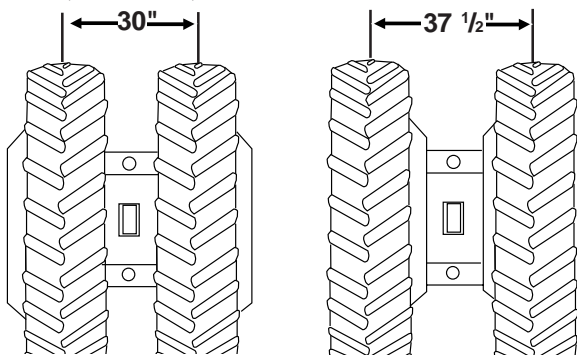

Dual wheel installation with offset in rims positioned for 30" row spacing.

Dual wheel installation with offset in rims positioned for wide (36" - 38") row spacing.

L0112-29(WGN55)

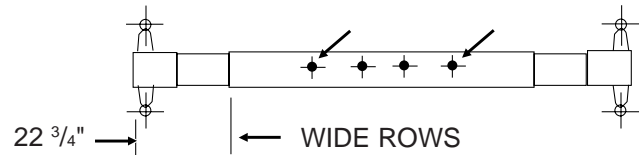
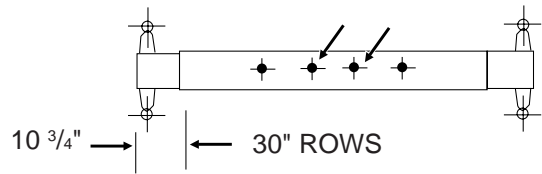

**NOTE: Retorque wheel nuts as follows:**

- After 4 hours use.
- After 16 hours use.
- Weekly during season.

**NOTE: On Row Crop wagons when axle location/tire width is set at the wide (36" - 38") row spacing, the single amber light assemblies at the rear of the wagon must be relocated to the outboard side of the mounting bracket.**

D02080140a.tif

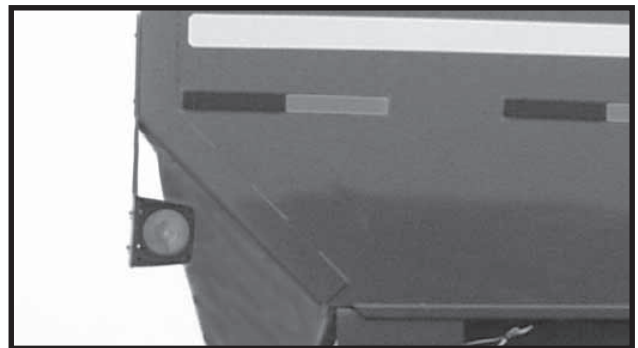

**Standard Location On Inboard Side Of Mounting Bracket**

D02080140b.tif

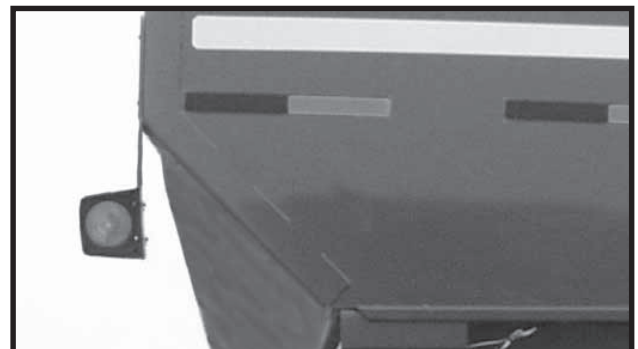

**Relocated To Outboard Side Of Mounting Bracket For Wide Row Spacing When Overall Width Is Greater Than 12' 6"**

# MAINTENANCE

## AXLE ADJUSTMENT (Wheel Wagon)

640/840 wheel wagons are factory assembled with the axle in the **shipping position** and **must be extended** to a 108" or 120" tire center-to-center operating position. Adjustment holes in the center axle allow for the axle width to be adjusted.

L0112-29(WGN12)

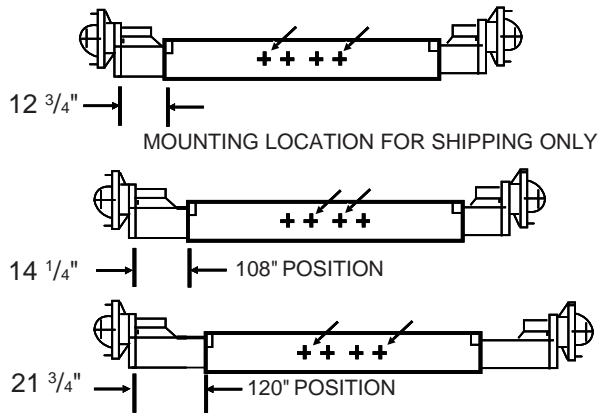

Remove the 1" x 12" cap screws on the center axle. Slide the axle stubs out approximately 1 1/2" and re-install cap screws in inner set of holes for 108" center-to-center axle setting. Slide axle stubs out approximately 9" and re-install cap screws in outer set of holes for 120" center-to-center axle setting. Torque bolts to 480 ft. lbs.

**NOTE:** To allow clearance between wagon tub and tire, 30.5" x 32" tires on the 640 wagon and 30.5" x 32" R-1 (traction tread) tires on the 840 wagon require 120" axle settings.

## AXLE ADJUSTMENT (Sof-Trak Wagon/UTC)

The Sof-Trak wagon and Utility Tracked Chassis is factory assembled with the axle in the **shipping position** and **must be extended** to a 108" or 120" operating position. Adjustment holes in the center axle allow for the axle setting to be adjusted.

L0112-30(WGN13)

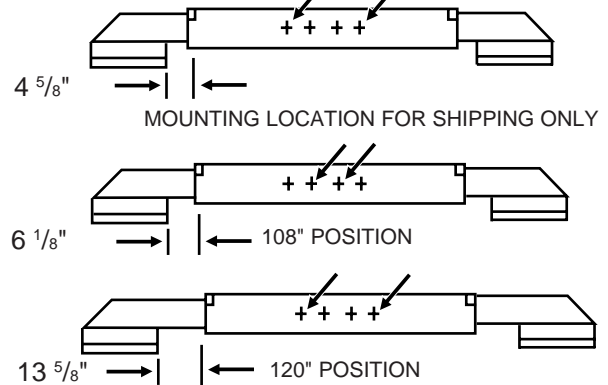

Remove the 1" x 12" cap screws on the center axle. Slide the axle stubs out approximately 1 1/2" and re-install cap screws in inner set of holes for 108" center-to-center axle setting. Slide axle stubs out approximately 9" and re-install cap screws in outer set of holes for 120" center-to-center axle setting. Torque bolts to 480 ft. lbs.



**WARNING:** Wide loads or loads with a high center of gravity may cause instability or rollover when operating the Utility Tracked Chassis on hillsides or in rough terrain.

**NOTE:** On Sof-Trak wagons/UTC (with 36" tracks) when the tracks are set at the 120" axle setting, the single amber light assemblies at the rear of the wagon must be relocated to the outboard side of the mounting bracket.

D02080140a.tif

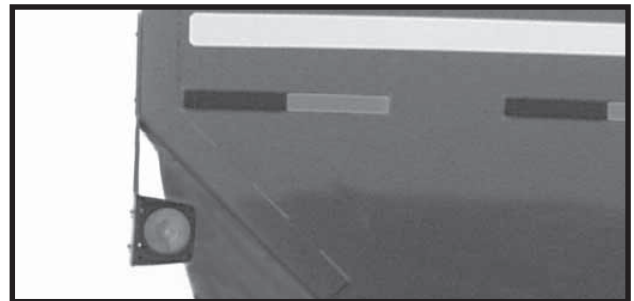

Standard Location On Inboard Side Of Mounting Bracket

D02080140b.tif

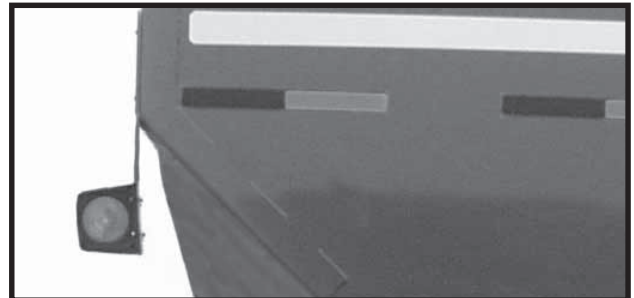

Relocated To Outboard Side Of Mounting Bracket For 36" Tracks On Wide Axle Setting When Overall Width Is Greater Than 12' 6"



# MAINTENANCE

## ELECTRONIC SCALE (Wheel/Row Crop Wagon)

The major elements of the electronic scale for wheel and row crop wagons are the indicator, 2 or 4 axle weigh beams, a hitch weigh beam, the junction box and the battery power cable.

### Wheel Wagon

(WGN14)

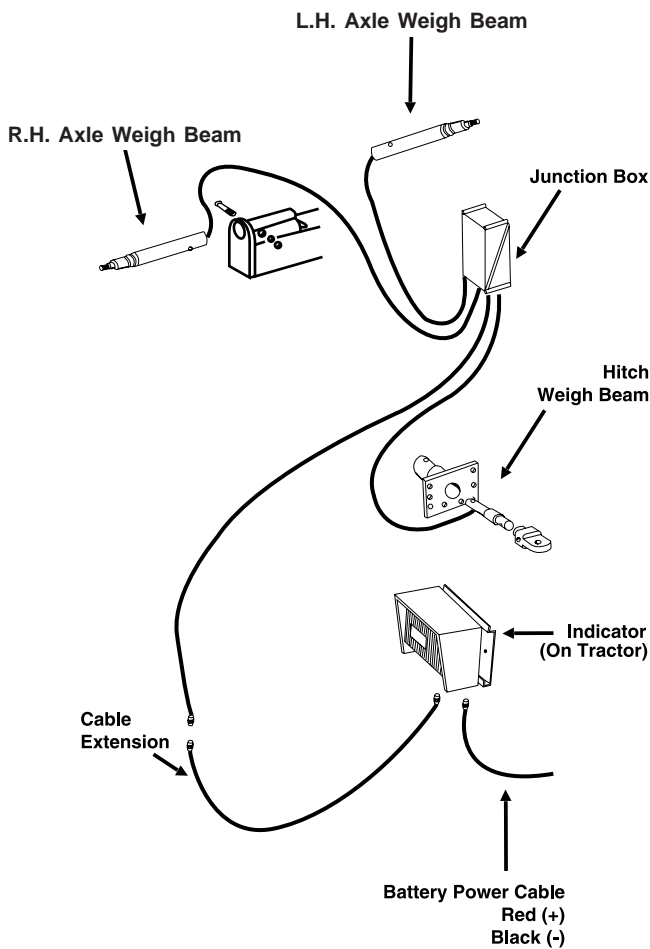

### Row Crop Wagon

(WGN14)

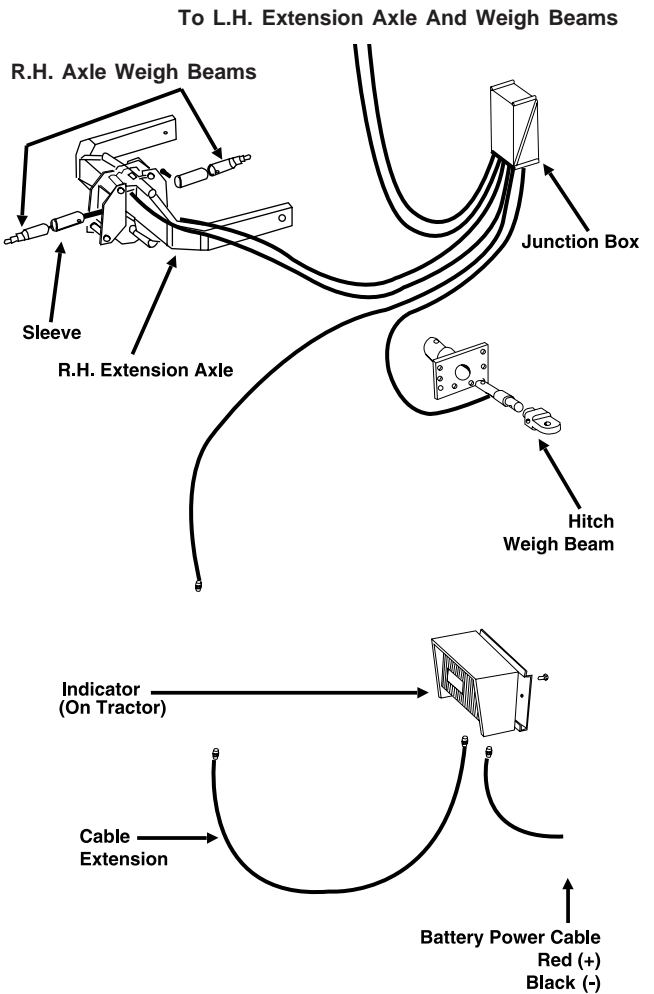

For additional information see "Electronic Scale Troubleshooting" for step-by-step procedures for troubleshooting problems commonly encountered with the electronic scale.

- The only tools required are as follows:
- Small screwdriver (straight blade)
  - No. 2 Phillips screwdriver

# MAINTENANCE

---

## ELECTRONIC SCALE (Utility Tracked Chassis)

The major elements of the electronic scale for the Utility Tracked Chassis/Grain Auger Wagon are the indicator, 4 corner-mounted load cells, the junction box and the battery power cable.

(WGN52)

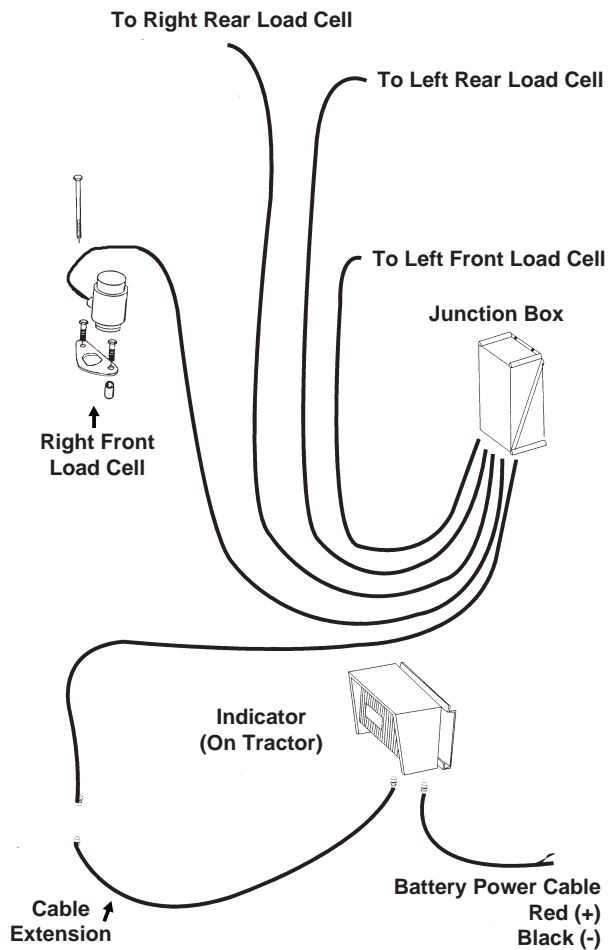

For additional information see “Electronic Scale Troubleshooting” for step-by-step procedures for troubleshooting problems commonly encountered with the electronic scale.

The only tools required are as follows:

- Small screwdriver (straight blade)
- No. 2 Phillips screwdriver

# MAINTENANCE

## ELECTRONIC SCALE TROUBLESHOOTING

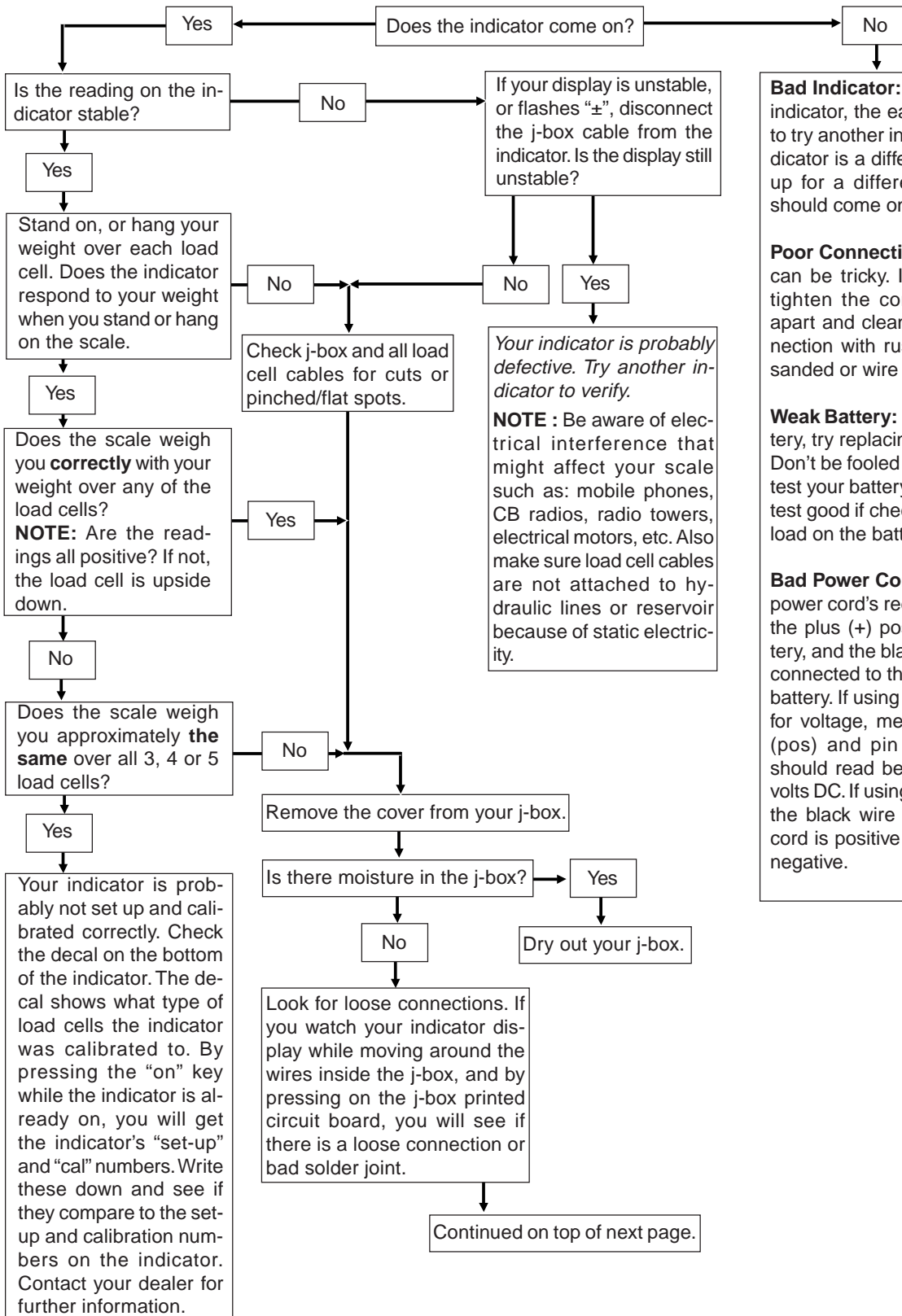

**Bad Indicator:** If you suspect a bad indicator, the easiest way to check is to try another indicator. Even if the indicator is a different model, or is set-up for a different scale, it at least should come on.

**Poor Connection:** Poor connections can be tricky. If in doubt, don't just tighten the connection, take them apart and clean them first. Any connection with rust or paint should be sanded or wire brushed.

**Weak Battery:** If you suspect the battery, try replacing it with another one. Don't be fooled if using a voltmeter to test your battery. A weak battery may test good if checked when there is no load on the battery.

**Bad Power Cord:** Make sure the power cord's red wire is connected to the plus (+) positive side of the battery, and the black (-) negative wire is connected to the negative side of the battery. If using a multimeter to check for voltage, measure between pin 1 (pos) and pin 2 (neg). The meter should read between 10.5 and 14.5 volts DC. If using a tractor power cord, the black wire on the tractor power cord is positive and the white wire is negative.

# MAINTENANCE

## ELECTRONIC SCALE TROUBLESHOOTING

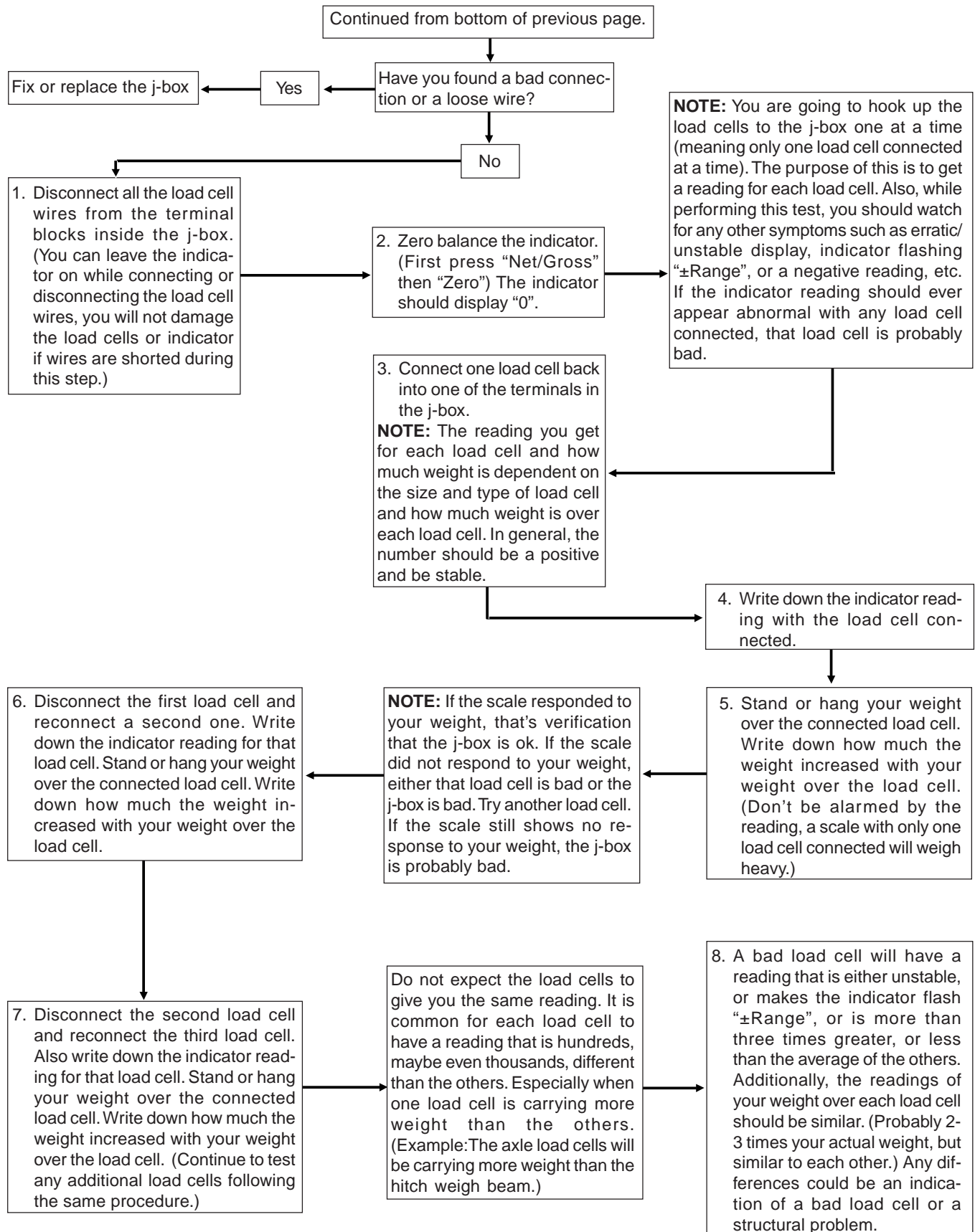

# MAINTENANCE

## END WHEEL/MID WHEEL BEARING REPLACEMENT (Sof-Trak Wagon/UTC)

**NOTE: Each mid wheel and end wheel assembly is equipped with a grease fitting for lubrication. The below procedure is used only for bearing replacement.**

### 1. End Wheel Procedure:

Follow the procedure described in "Tire Repair (Sof-Trak Wagon/UTC)" to raise machine, remove mud scraper, release track tension and remove inner and outer sidebars nearest the end wheel being serviced.

### Mid Wheel Procedure:

Follow the procedure described in "Tire Repair (Sof-Trak Wagon/UTC)" to raise machine, remove mud scraper, release track tension, remove inner and outer sidebars and both end wheels nearest mid wheel being serviced. Drop the mid wheel to clear the track carriage and roll it to the closest end of the track for removal. If there is a mid wheel between the end wheel and the mid wheel being serviced, it must be removed also.

2. Remove double nuts and slide spindle from hub.
3. Remove bearings, seals and cups and discard. Clean and dry hub.
4. Press in new bearing cups with thickest edge facing in.
5. Pack bearings with heavy duty wheel bearing grease thoroughly forcing grease between roller cone and bearing cage. Also fill the space between the bearing cups in the hub with grease.
6. Place inner bearing in place and install seal.
7. Clean spindle and install in hub.
8. Install outer bearing, seal and stepped nut. Tighten stepped nut until there is some drag when the spindle is rotated. This assures that all bearing surfaces are in contact. Back off stepped nut  $\frac{1}{4}$  turn or until there is only slight drag when rotating the hub. Install jam nut to lock against stepped nut.

### 9. End Wheel Procedure:

Follow the procedure described in "Tire Repair (Sof-Trak Wagon/UTC)" to reinstall the sidebars and mud scraper. Check track alignment, track tension and mud scraper clearance after completing the procedure.

### Mid Wheel Procedure:

Raise mid wheel assembly into position under the track carriage, install inner and outer spindle bolts and torque to 1360 ft. lbs. Follow the procedure described in "Tire Repair (Sof-Trak Wagon/UTC)" to reinstall end wheel assembly, sidebars, track tension and mud scraper. Check track alignment, track tension and mud scraper clearance after completing the procedure.

(WGN44a)

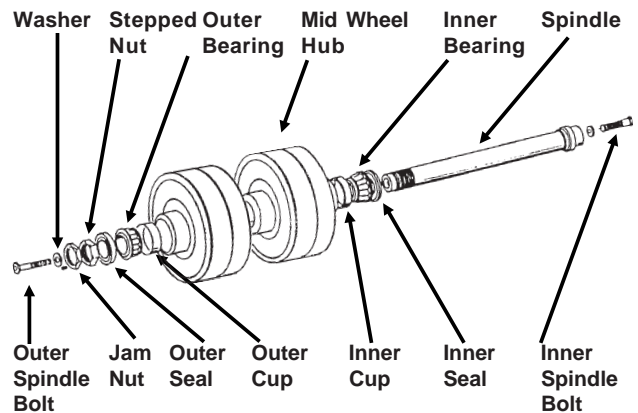

(WGN83b)

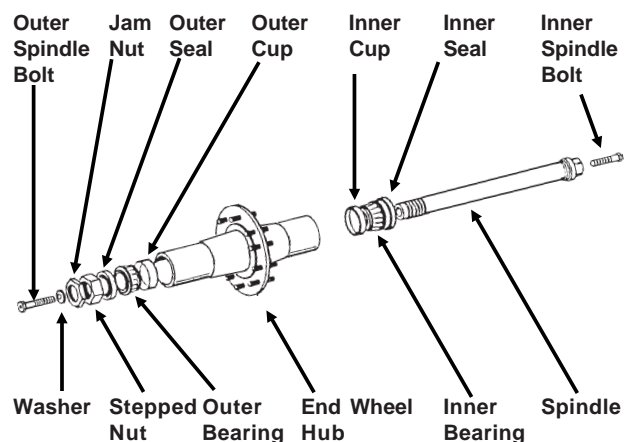

# MAINTENANCE

## WHEEL BEARING REPLACEMENT (Wheel/Row Crop Wagon)

**NOTE: See “Inside Tire Repair Or Removal” section of this manual for instruction on tire removal/access to inner wheel hubs on Row Crop Wagons.**

1. Raise tire clear of ground and remove wheel.
2. Remove dust cap attachment hardware and remove cap from wheel hub.
3. Remove cotter pin, axle nut and 2" washer.
4. Slide hub from axle spindle, using a hub puller if necessary.
5. Remove bearings and cups from hub and discard. Thoroughly clean and dry wheel hub.
6. Press in new bearing cups with thickest edges facing in.
7. Pack bearing with heavy duty wheel bearing grease, thoroughly forcing grease between roller cone and bearing cage. Also fill the space between the bearing cups in the hub with grease.
8. Place inner bearing in hub and press in new grease seal with lip pointing towards bearing.
9. Clean axle spindle and install hub.
10. Install outer bearing, 2" washer and slotted hex nut. Tighten slotted hex nut while rotating the hub until there is some drag. This assures that all bearing surfaces are in contact. Back off slotted nut to nearest locking slot and install cotter pin. Check for endplay in bearings.
11. Fill dust cap half full of wheel bearing grease and install on hub with attachment bolts.
12. Install wheel and remove jack. Torque wheel nuts to 425 ft. lbs.

## PREPARATION FOR STORAGE

- Always store the machine in a dry sheltered area if possible.
- Remove all trash that may be wrapped on sprockets or shafts and remove dirt that can draw moisture.
- Remove dump door and clean out all accumulated grain and debris from auger chamber.
- Wash machine inside and out.
- Clean all drive chains and coat with a rust preventative spray or remove chains and submerge in oil.
- Lubricate machine at all lubrication points.
- If possible, remove weight from all tires, particularly if the unit is being stored outdoors.
- Repaint any areas where paint has been removed. This is particularly important in the inside of the grain tank. Rust in this area will shorten the life of the wagon as well as prevent grain from smoothly sliding to the bottom of the tank.
- Inspect the machine for parts that are in need of replacement and order during the “off” season.
- Coat exposed surface of all cylinder piston rods with grease or rust preventative spray.

HTA002(WGN19)

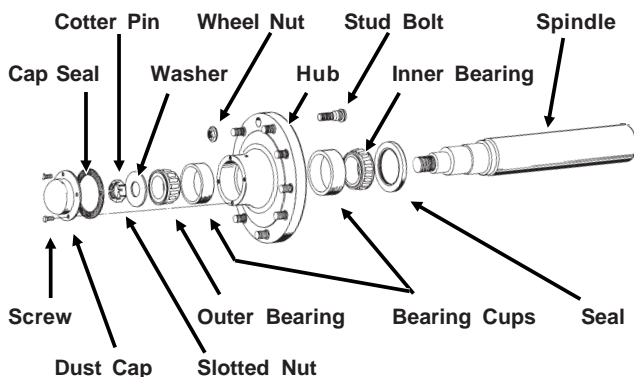



# MAINTENANCE

---

# PARTS LIST INDEX

---

## DRIVE COMPONENTS

Cylinders ..... P43  
Gearbox ..... P10  
Horizontal Auger Drive ..... P22  
Horizontal Augers And Bearings ..... P26  
PTO Assembly ..... P2  
Vertical Auger - Lower Section ..... P14  
Vertical Auger - Upper Section ..... P12  
Vertical Auger Drive ..... P18

## MAIN FRAME

Axles ..... P34  
End Wheel (Sof-Trak/UTC) ..... P40  
Grain Flow Control Gate ..... P28  
Grain Tank Panels ..... P32  
Hitch Cap/Plate ..... P42  
Hub And Tire Assembly (Wheel/Row Crop) ..... P37  
Jack Assembly ..... P48  
Mid Wheel (Sof-Trak/UTC) ..... P39  
Optional Safety Chain ..... P43  
Track And Carriage (Sof-Trak/UTC) ..... P38

## ELECTRICAL

Safety/Warning And Work Lights ..... P52  
Electronic Scale Components ..... P50

Decals, Paint And Miscellaneous ..... P54

Numerical Index ..... a

# PTO ASSEMBLY

## 1 3/8"-21 SPLINE YOKE

640

WAC008/WAC009(WGN20a)

STYLE A

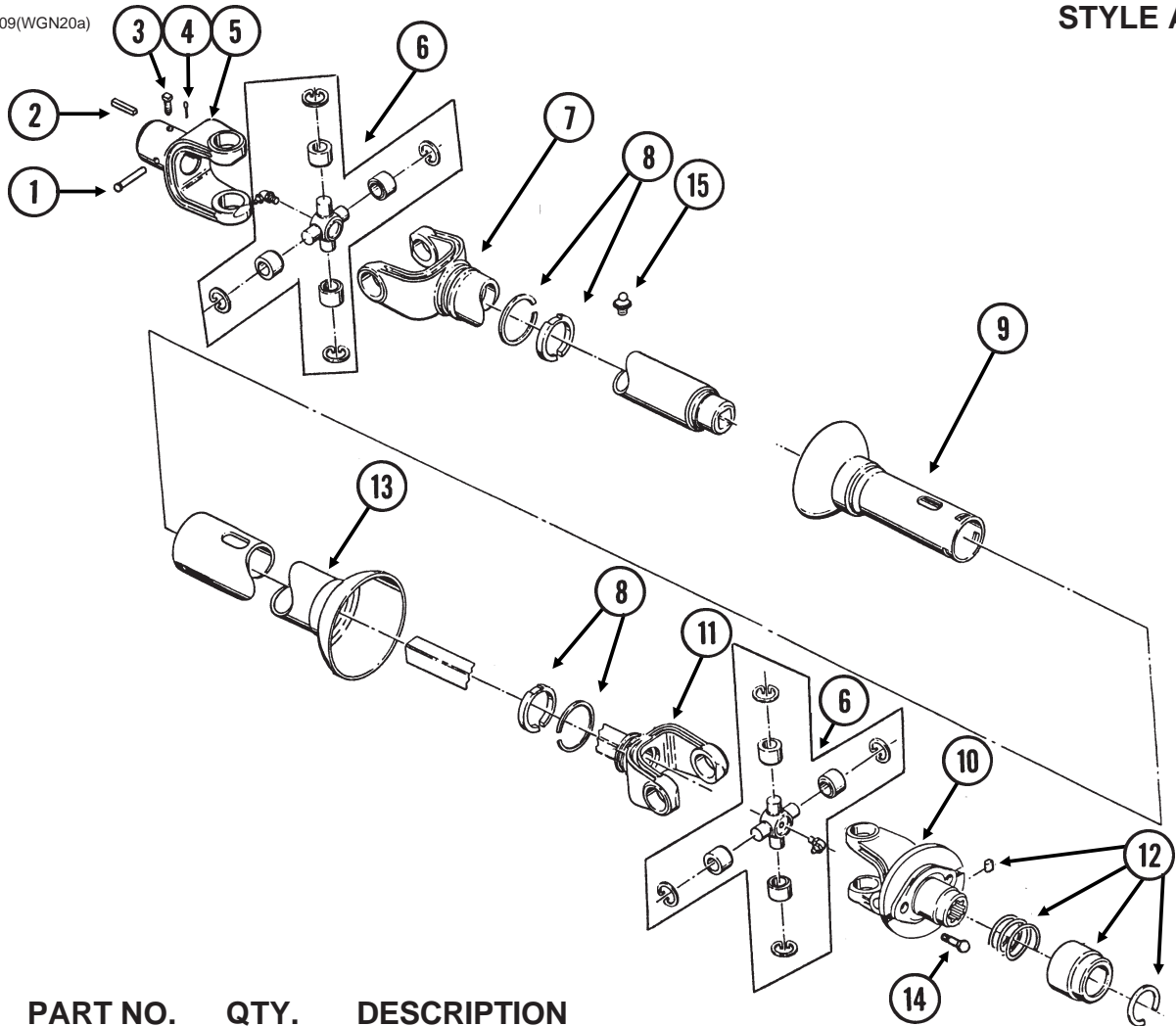

ITEM	PART NO.	QTY.	DESCRIPTION
1.	G10556	1	Clevis Pin, 3/8" x 2 1/2"
2.	GD0147	1	Key, 1/4" x 1/4" x 2"
3.	G10700	1	Set Screw, 3/8"-16 x 1"
4.	G10456	1	Cotter Pin, 1/8" x 3/4"
5.	GR0343	1	End Yoke
6.	GR0344	2	U-Joint Repair Kit W/Grease Fitting
	G10910	-	Grease Fitting, 65°, 1/8"-27
7.	GR0345	1	Yoke And Tube ( <b>Sub GR0342</b> )
8.	GR1237	-	Nylon Repair Kit
9.	GR0347	1	Inner Guard, Includes Item 8 - Machine Half
10.	GR1236	1	Ball Shear And Yoke Assembly, Includes Item 12
11.	GR1235	1	Yoke And Shaft Assembly ( <b>Sub GR1238</b> )
12.	GR0254	-	Safety Slide Lock Repair Kit
13.	GR1234	1	Outer Guard, Tractor Half (Item 8)
14.	G10001	1	Hex Head Cap Screw, 3/8"-16 x 1"
	G10108	1	Lock Nut, 3/8"-16
15.	GR1430	1	Grease Fitting, 3/16", Drive-In
A.	GR0342	-	PTO Half - Machine (Items 5-9 And 15)
B.	GR1238	-	PTO Half - Tractor (Items 6, 8 And 10-14)

# PTO ASSEMBLY

## 1 3/8"-21 SPLINE YOKE

640

WAC009(WGN21)

STYLE B

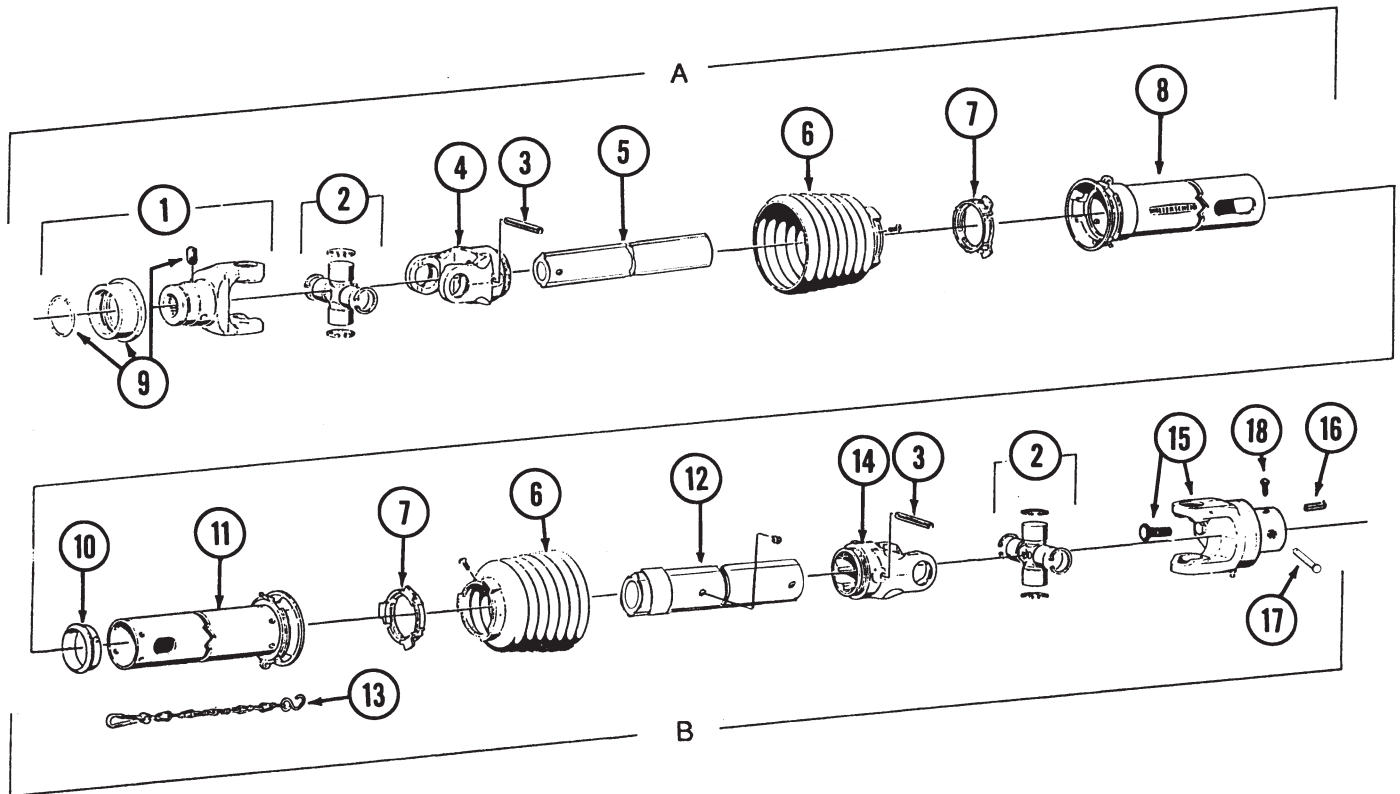

ITEM	PART NO.	QTY.	DESCRIPTION
1.	GR1340	1	Yoke, Includes Item 9
2.	GR1329	2	Cross And Bearing Kit W/Grease Fitting
	GR1300	-	Grease Fitting, 67.5°, Metric
3.	GR1330	2	Spring Pin
4.	GR1331	1	Inboard Yoke
5.	GR1332	1	Inner Profile
6.	GR1336	2	Guard Cone W/Screw
7.	GR1220	2	Bearing Ring
8.	GR1337	1	Outer Guard Tube (Oval)
9.	GR1339	-	Quick Disconnect Kit
10.	GR1222	1	Support Bearing
11.	GR1338	1	Inner Guard Tube (Round)
12.	GR1333	1	Profile And Sleeve W/Grease Fitting
	GR1430	-	Grease Fitting, 3/16", Drive-In
13.	GR1221	1	Safety Chain
14.	GR1334	1	Inboard Yoke
15.	GR1335	1	Clutch W/Shear Bolt, Nut And Grease Fitting
	G10060	-	Hex Head Cap Screw, 5/16"-18 x 2 1/2"
	G10109	-	Lock Nut, 5/16"-18
	GR1438	-	Special Grease Fitting
16.	GD0147	1	Key, 1/4" x 1/4" x 2 1/2"
17.	G10556	1	Clevis Pin, 3/8" x 2 1/2"
	G10456	1	Cotter Pin, 1/8" x 3/4"
18.	G10700	1	Set Screw, 3/8"-16 x 1"
A.	GR1341	-	PTO Half-Tractor (Items 1-9)
B.	GR1343	-	PTO Half-Machine (Items 2, 3, 6, 7 And 10-15)

# PTO ASSEMBLY HEAVY DUTY 1 3/4"-20 SPLINE YOKE

640

WAC008/WAC009(WGN20a)

STYLE A

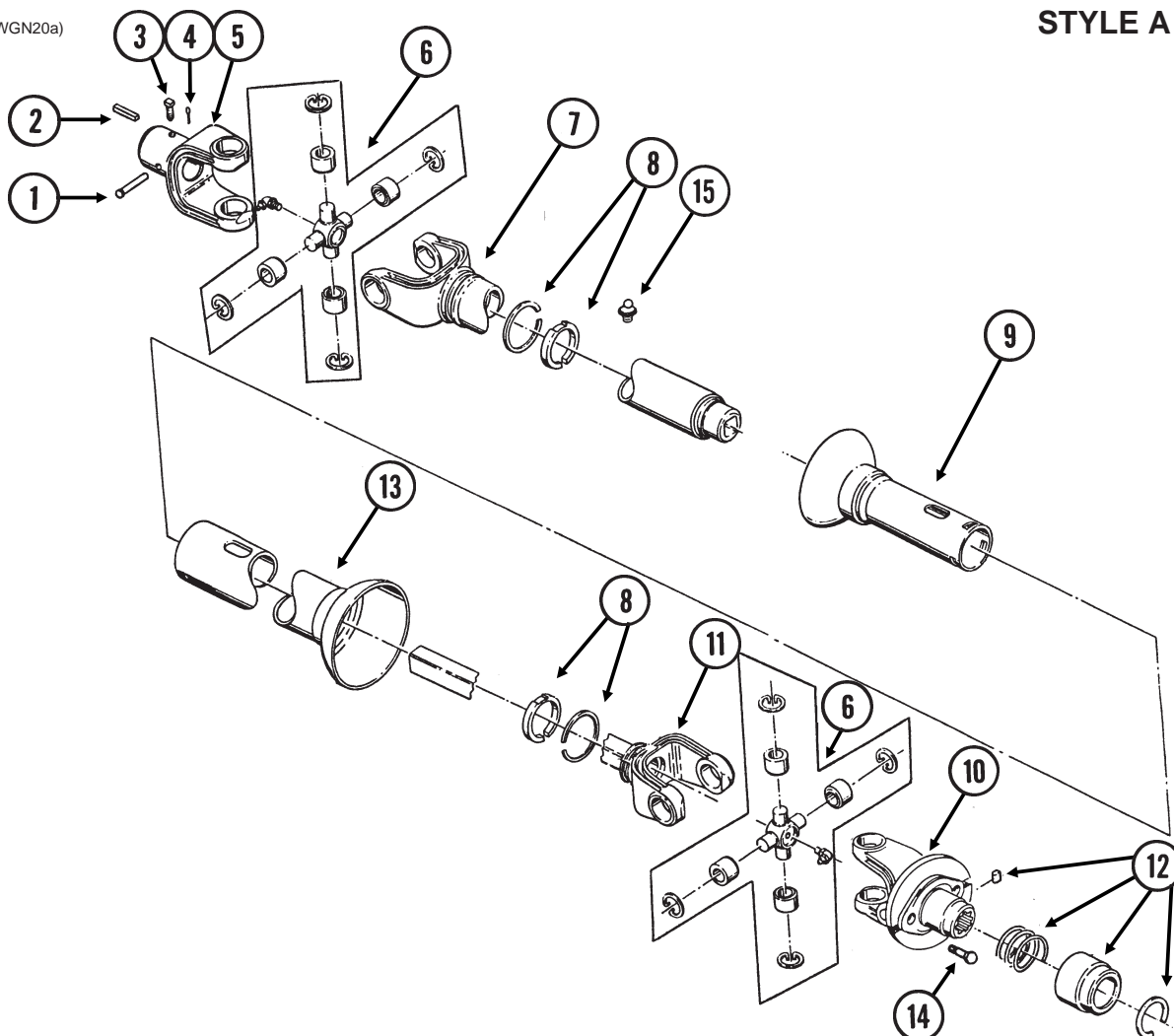

ITEM	PART NO.	QTY.	DESCRIPTION
1.	G10556	1	Clevis Pin, 3/8" x 2 1/2"
2.	GD0147	1	Key, 1/4" x 1/4" x 2"
3.	G10700	1	Set Screw, 3/8"-16 x 1"
4.	G10456	1	Cotter Pin, 1/8" x 3/4"
5.	GR0343	1	End Yoke
6.	GR0344	2	U-Joint Repair Kit W/Grease Fitting
	G10910	-	Grease Fitting, 65°, 1/8"-27
7.	GR0345	1	Yoke And Tube ( <b>Sub GR0342</b> )
8.	GR1237	-	Nylon Repair Kit
9.	GR0347	1	Inner Guard, Includes Item 8 - Machine Half
10.	GR1239	1	Ball Shear And Yoke Assembly, Includes Item 12
11.	GR1235	1	Yoke And Shaft Assembly ( <b>Sub GR1240</b> )
12.	GR1243	-	Safety Slide Lock Repair Kit
13.	GR1234	1	Outer Guard, Tractor Half (Item 8)
14.	G10001	1	Hex Head Cap Screw, 3/8"-16 x 1"
	G10108	1	Lock Nut, 3/8"-16
15.	GR1430	1	Grease Fitting, 3/16", Drive-In
A.	GR0342	-	PTO Half - Machine (Items 5-9 And 15)
B.	GR1240	-	PTO Half - Tractor (Items 6, 8 And 10-14)

# PTO ASSEMBLY HEAVY DUTY 1 3/4"-20 SPLINE YOKE

640

WAC008(WGN21)

STYLE B

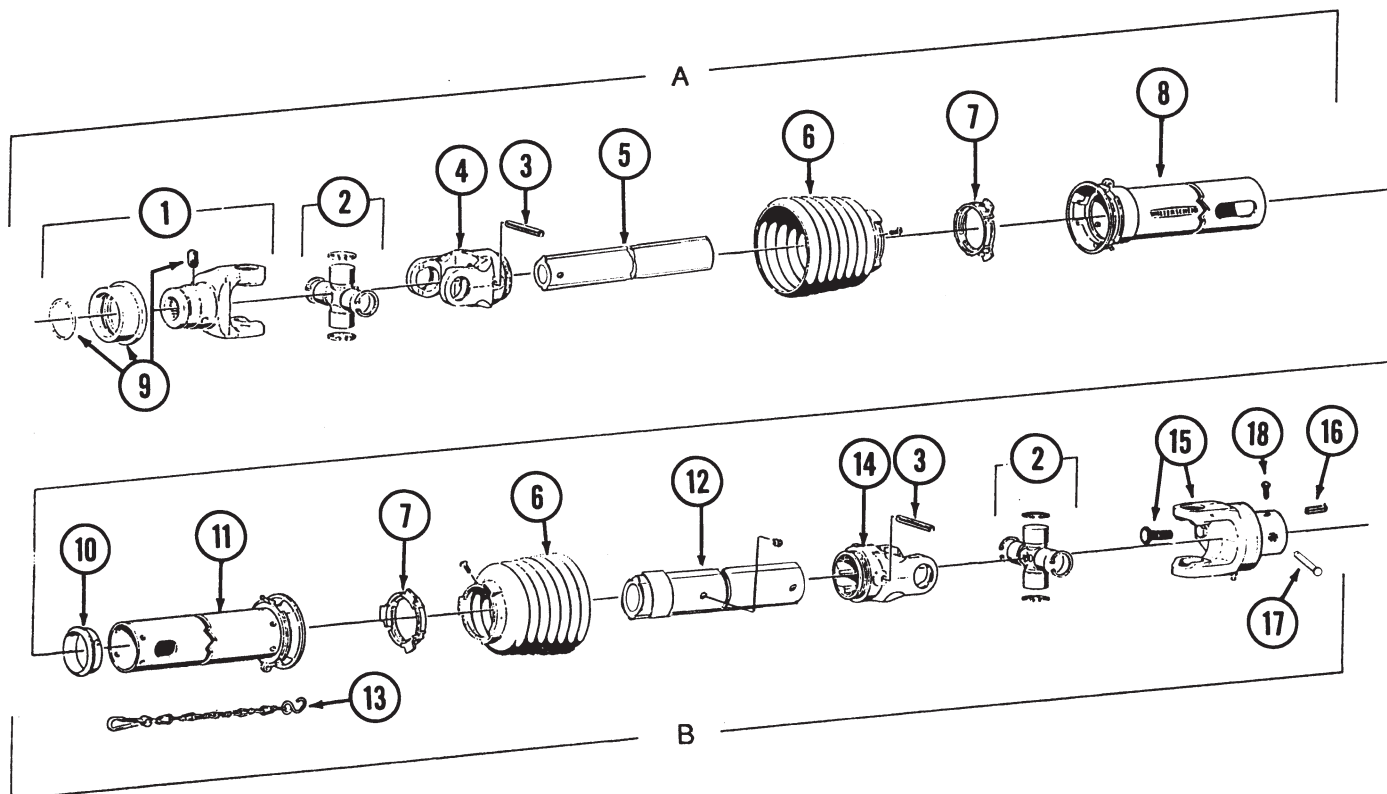

ITEM	PART NO.	QTY.	DESCRIPTION
1.	GR1328	1	Yoke, Includes Item 9
2.	GR1329	2	Cross And Bearing Kit W/Grease Fitting
	GR1300	-	Grease Fitting, 67.5°, Metric
3.	GR1330	2	Spring Pin
4.	GR1331	1	Inboard Yoke
5.	GR1332	1	Inner Profile
6.	GR1336	2	Guard Cone W/Screw
7.	GR1220	2	Bearing Ring
8.	GR1337	1	Outer Guard Tube (Oval)
9.	GR1246	-	Quick Disconnect Kit
10.	GR1222	1	Support Bearing
11.	GR1338	1	Inner Guard Tube (Round)
12.	GR1333	1	Profile And Sleeve W/Grease Fitting
	GR1430	-	Grease Fitting, 3/16", Drive-In
13.	GR1221	1	Safety Chain
14.	GR1334	1	Inboard Yoke
15.	GR1335	1	Clutch W/Shear Bolt, Nut And Grease Fitting
	G10060	-	Hex Head Cap Screw, 5/16"-18 x 2 1/2"
	G10109	-	Lock Nut, 5/16"-18
	GR1438	-	Special Grease Fitting
16.	GD0147	1	Key, 1/4" x 1/4" x 2"
17.	G10556	1	Clevis Pin, 3/8" x 2 1/2"
	G10456	1	Cotter Pin, 1/8" x 3/4"
18.	G10700	1	Set Screw, 3/8"-16 x 1"
A.	GR1342	-	PTO Half-Tractor (Items 1-9)
B.	GR1343	-	PTO Half-Machine (Items 2, 3, 6, 7 And 10-15)



# PTO ASSEMBLY

## 1 3/8"-21 SPLINE YOKE

840/1040

WAC008/WAC00(WGN20a)

STYLE A

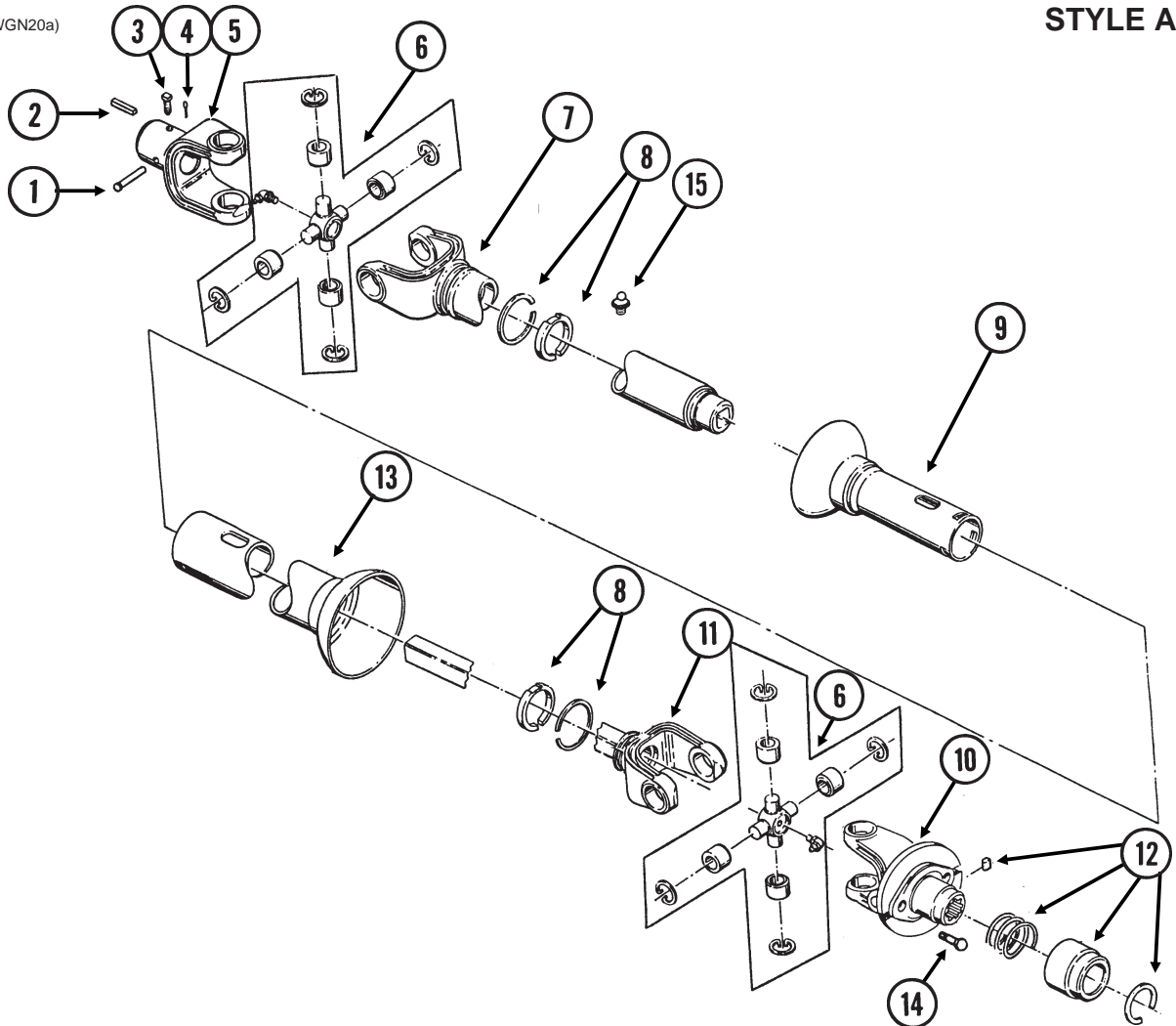

ITEM	PART NO.	QTY.	DESCRIPTION
1.	G10563	1	Clevis Pin, 3/8" x 3 1/4"
2.	GD0144	1	Key, 3/8" x 3/8" x 2 1/2"
3.	G10700	1	Set Screw, 3/8"-16 x 1"
4.	G10456	1	Cotter Pin, 1/8" x 3/4"
5.	GR0239	1	End Yoke
6.	GR0241	2	U-Joint Repair Kit W/Grease Fitting
	G10910	-	Grease Fitting, 65°, 1/8"-27
7.	GR0242	1	Yoke And Tube ( <b>Sub GR0240</b> )
8.	GR1231	-	Nylon Repair Kit
9.	GR0238	1	Inner Guard, Includes Item 8 - Machine Half
10.	GR1227	1	Ball Shear And Yoke Assembly, Includes Item 12
11.	GR1228	1	Yoke And Shaft Assembly ( <b>Sub GR1229</b> )
12.	GR0254	-	Safety Slide Lock Repair Kit
13.	GR1247	1	Outer Guard, Includes Item 8 - Tractor Half
14.	G10001	1	Hex Head Cap Screw, 3/8"-16 x 1"
	G10108	1	Lock Nut, 3/8"-16
15.	GR1430	1	Grease Fitting, 3/16", Drive-In
A.	GR0240	-	PTO Half-Machine (Items 5-9 And 15)
B.	GR1229	-	PTO Half-Tractor (Items 10-14)

# PTO ASSEMBLY

## 1 3/8"-21 SPLINE YOKE

840/1040

WAC009(WGN22)

STYLE B

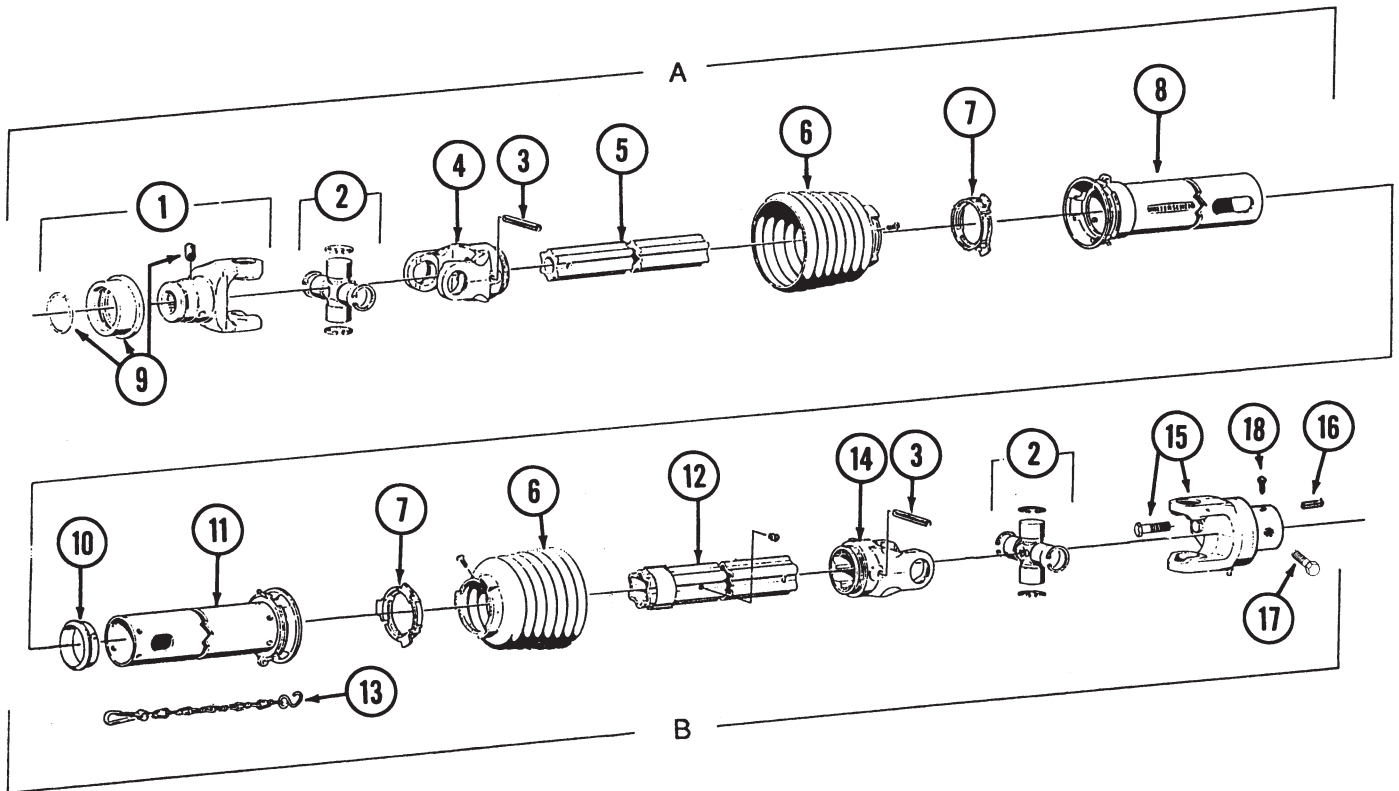

ITEM	PART NO.	QTY.	DESCRIPTION
1.	GR1209	1	Yoke, Includes Item 9
2.	GR1210	2	Cross And Bearing Kit W/Grease Fitting
	GR1300	-	Grease Fitting, 67.5°, Metric
3.	GR1211	2	Spring Pin
4.	GR1212	1	Inboard Yoke
5.	GR1213	1	Inner Profile
6.	GR1217	2	Guard Cone W/Screw
7.	GR1220	2	Bearing Ring
8.	GR1218	1	Outer Guard Tube
9.	GR1245	-	Quick Disconnect Kit
10.	GR1222	1	Support Bearing
11.	GR1219	1	Inner Guard Tube
12.	GR1214	1	Profile And Sleeve W/Grease Fitting
	GR1430	-	Grease Fitting, 3/16", Drive-In
13.	GR1221	1	Safety Chain
14.	GR1215	1	Inboard Yoke
15.	GR1216	1	Clutch W/Shear Bolt, Nut And Grease Fitting
	G10049	-	Hex Head Cap Screw, 3/8"-16 x 2 1/2"
	G10108	-	Lock Nut, 3/8"-16
	GR1438	-	Special Grease Fitting
16.	GD0144	1	Key, 3/8" x 3/8" x 2 1/2"
17.	G10326	1	Hex Head Cap Screw, 3/8"-16 x 3 3/4"
	G10108	1	Lock Nut, 3/8"-16
18.	G10700	1	Set Screw, 3/8"-16 x 1"
A.	GR1225	-	PTO Half-Tractor (Items 1-9)
B.	GR1224	-	PTO Half-Machine (Items 2, 3, 6, 7 And 10-15)

# PTO ASSEMBLY HEAVY DUTY 1 3/4"-20 SPLINE YOKE

840/1040

WAC008/WAC009(WGN20)

STYLE A

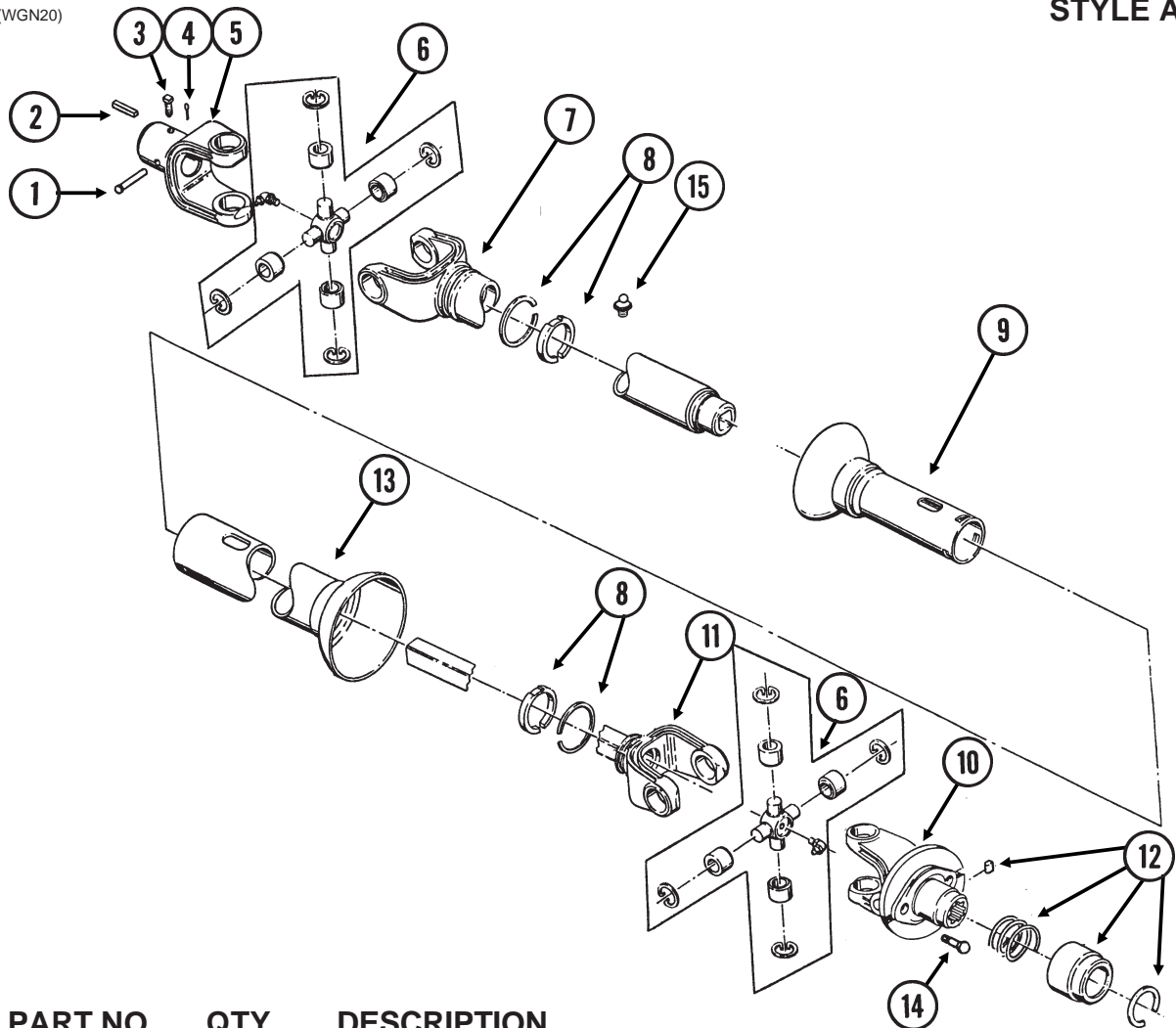

ITEM	PART NO.	QTY.	DESCRIPTION
1.	G10563	1	Clevis Pin, 3/8" x 3 1/4"
2.	GD0144	1	Key, 3/8" x 3/8" x 2 1/2"
3.	G10700	1	Set Screw, 3/8"-16 x 1"
4.	G10456	1	Cotter Pin, 1/8" x 3/4"
5.	GR0239	1	End Yoke
6.	GR0241	2	U-Joint Repair Kit W/Grease Fitting
	G10910	-	Grease Fitting, 65°, 1/8"-27
7.	GR0242	1	Yoke And Tube ( <b>Sub GR0240</b> )
8.	GR1231	-	Nylon Repair Kit
9.	GR0238	1	Inner Guard, Includes Item 8 - Machine Half
10.	GR1233	1	Ball Shear And Yoke Assembly, Includes Item 12
11.	GR1228	1	Yoke And Shaft Assembly ( <b>Sub GR1232</b> )
12.	GR1243	-	Safety Slide Lock Repair Kit
13.	GR1247	1	Outer Guard, Includes Item 8 - Tractor Half
14.	G10001	1	Hex Head Cap Screw, 3/8"-16 x 1"
	G10108	1	Lock Nut, 3/8"-16
15.	GR1430	1	Grease Fitting, 3/16", Drive-In
A.	GR0240	-	PTO Half-Machine (Items 5-9 And 15)
B.	GR1232	-	PTO Half-Tractor (Items 8 And 10-14)

# PTO ASSEMBLY HEAVY DUTY 1 3/4"-20 SPLINE YOKE

840/1040

WAC008(WGN22)

STYLE B

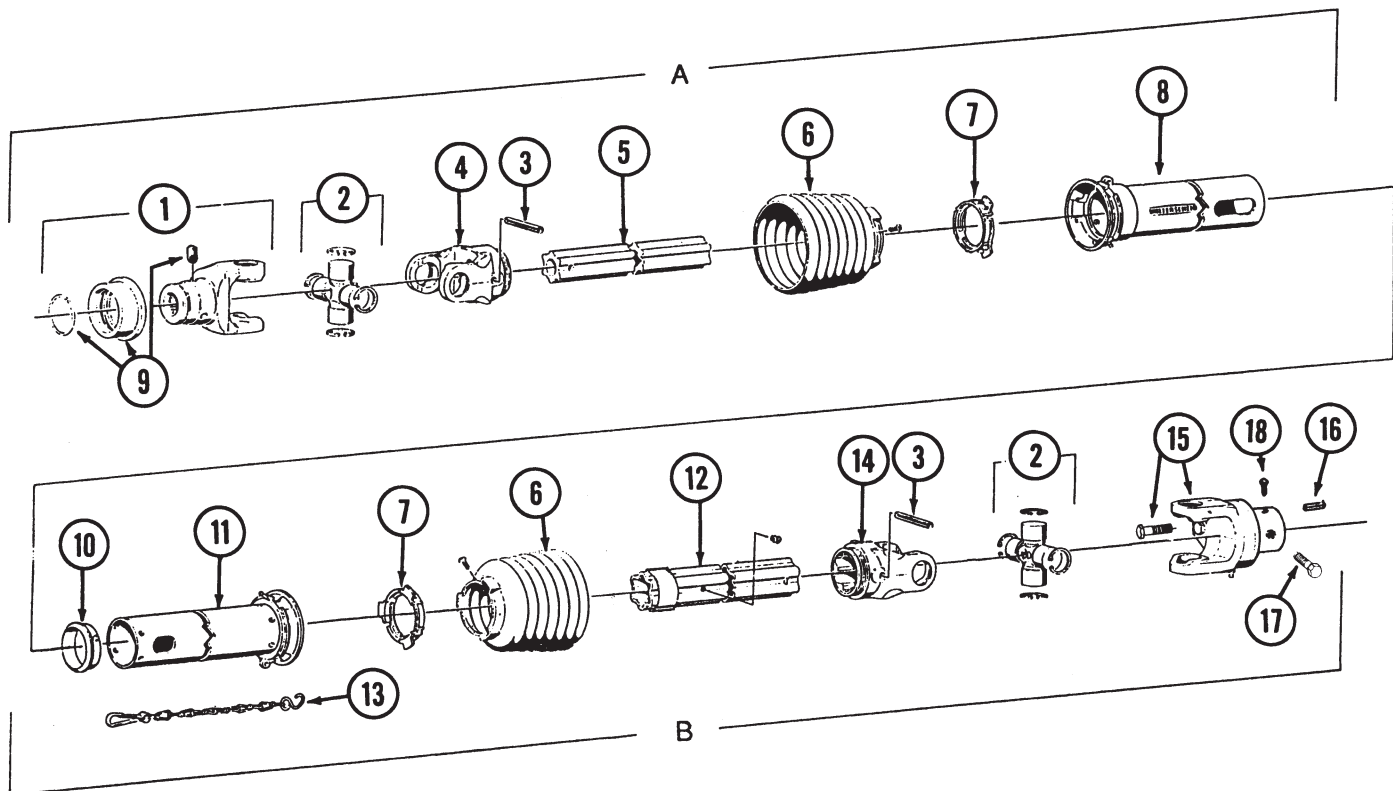

ITEM	PART NO.	QTY.	DESCRIPTION
1.	GR1223	1	Yoke, Includes Item 9
2.	GR1210	2	Cross And Bearing Kit W/Grease Fitting
	GR1300	-	Grease Fitting, 67.5°, Metric
3.	GR1211	2	Spring Pin
4.	GR1212	1	Inboard Yoke
5.	GR1213	1	Inner Profile
6.	GR1217	2	Guard Cone W/Screw
7.	GR1220	2	Bearing Ring
8.	GR1218	1	Outer Guard Tube
9.	GR1246	-	Quick Disconnect Kit
10.	GR1222	1	Support Bearing
11.	GR1219	1	Inner Guard Tube
12.	GR1214	1	Profile And Sleeve W/Grease Fitting
	GR1430	-	Grease Fitting, 3/16", Drive-In
13.	GR1221	1	Safety Chain
14.	GR1215	1	Inboard Yoke
15.	GR1216	1	Clutch W/Shear Bolt, Nut And Grease Fitting
	G10049	-	Hex Head Cap Screw, 3/8"-16 x 2 1/2"
	G10108	-	Lock Nut, 3/8"-16
	GR1438	-	Special Grease Fitting
16.	GD0144	1	Key, 3/8" x 3/8" x 2 1/2"
17.	G10326	1	Hex Head Cap Screw, 3/8"-16 x 3 3/4"
	G10108	1	Lock Nut, 3/8"-16
18.	G10700	1	Set Screw, 3/8"-16 x 1"
A.	GR1226	-	PTO Half-Tractor (Items 1-9)
B.	GR1224	-	PTO Half-Machine (Items 2, 3, 6, 7 And 10-15)

GBX002(WGN23a)

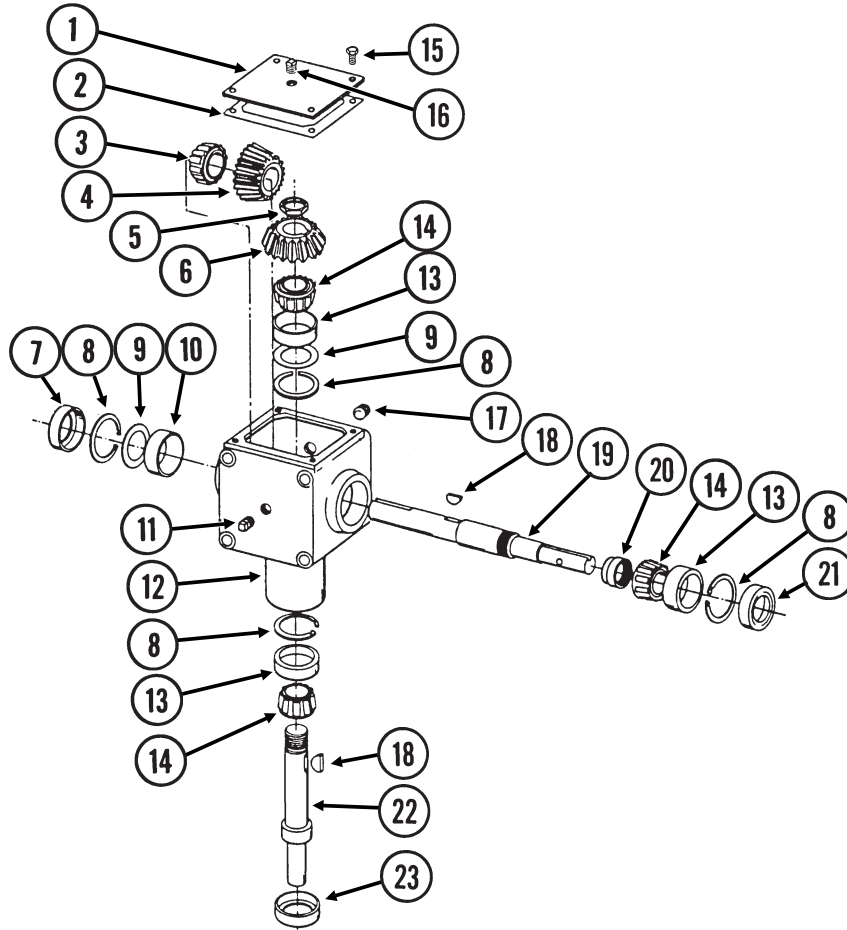

ITEM	PART NO.	QTY.	DESCRIPTION
1.	GR0328	1	Cover
2.	GR0336	1	Gasket
3.	GA0715	1	Bearing
4.	GR0341	1	Bevel Gear
5.	GR0331	1	Stake Nut, 1 3/8"-18
6.	GR0329	1	Bevel Gear
7.	GR0339	1	Seal
8.	G10143	4	Internal Retaining Ring, 2 5/8"
9.	GR0338	-	Shim
10.	GR0340	1	Cup
11.	G10121	1	Pipe Plug, 3/8" NPT
12.	GR0327	1	Housing
13.	GR0190	3	Cup
14.	GA0714	3	Bearing
15.	G10018	4	Hex Head Cap Screw, 5/16"-18 x 5/8"
16.	GR0306	1	Vent Plug, 3/8" NPT
17.	G10142	1	Pipe Plug, 3/8" NPT
18.	GR0334	2	Woodruff Key
19.	GR0333	1	Shaft
20.	GR0330	1	Stake Nut, 1 5/8"-18
21.	GR0335	1	Seal
22.	GR0332	1	Shaft
23.	GR0302	1	Seal
A.	GA0406	1	Gearbox Complete (Items 1-23)

# GEARBOX

840/1040

GBX001(WGN24a)

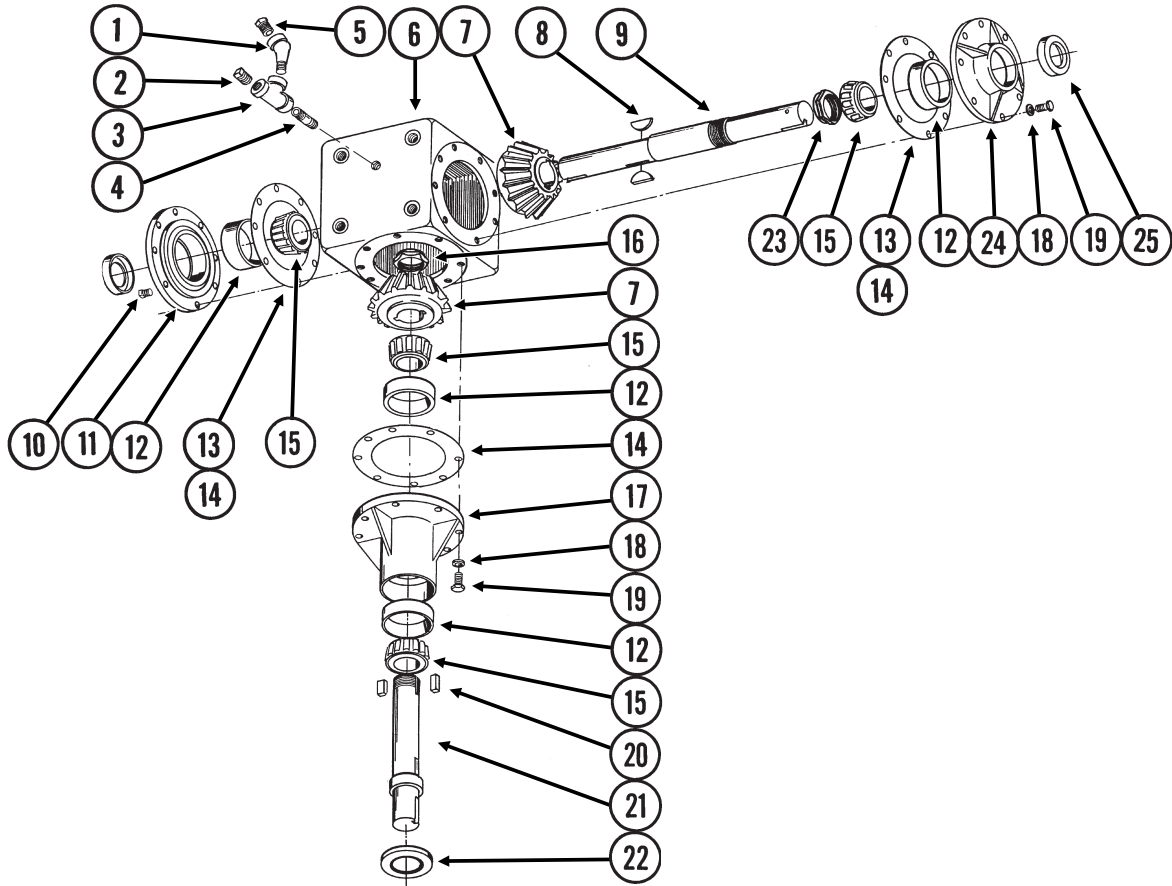

ITEM	PART NO.	QTY.	DESCRIPTION
1.	G10123	1	Elbow, 90°, 3/8" Male NPT To Female
2.	G10142	-	Pipe Plug, 3/8" NPT
3.	G10749	-	Tee, 3/8" Female NPT
4.	G10124	1	Pipe Nipple, 3/8" NPT x 1 1/2" Long
5.	GR0306	1	Vent Plug, 3/8" NPT
6.	GR0291	1	Housing
7.	GR0295	2	Bevel Gear Set (Pair)
8.	GR0297	2	Woodruff Key, "G"
9.	GR0300	1	Shaft
10.	G10135	1	Pipe Plug, 1/4" NPT
11.	GR0293	1	Cover
12.	GR0296	4	Cup
13.	GR0304	-	Shim
14.	GR0305	3	Gasket
15.	GA0699	4	Bearing
16.	GR0299	1	Stake Nut, 1 3/4"-18
17.	GR0294	1	Hub
18.	G10228	24	Lock Washer, 1/2"
19.	G10037	24	Hex Head Cap Screw, 1/2"-13 x 1 1/4"
20.	GR0307	2	Key, 3/8" x 3/8" x 1 3/8"
21.	GR0301	1	Shaft
22.	GR0303	1	Seal
23.	GR0298	1	Stake Nut, 2"-18
24.	GR0292	1	Cover
25.	GR0302	2	Seal
A.	GA0624	-	Gearbox Complete (Items 5-25)



# VERTICAL AUGER - UPPER SECTION

640

WVA007(WGN25b/WGN28e)

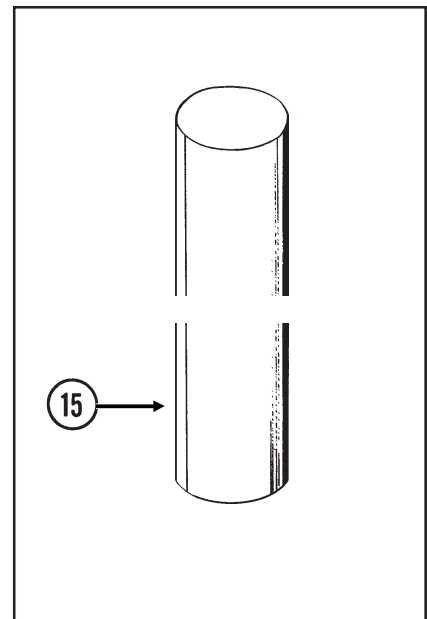
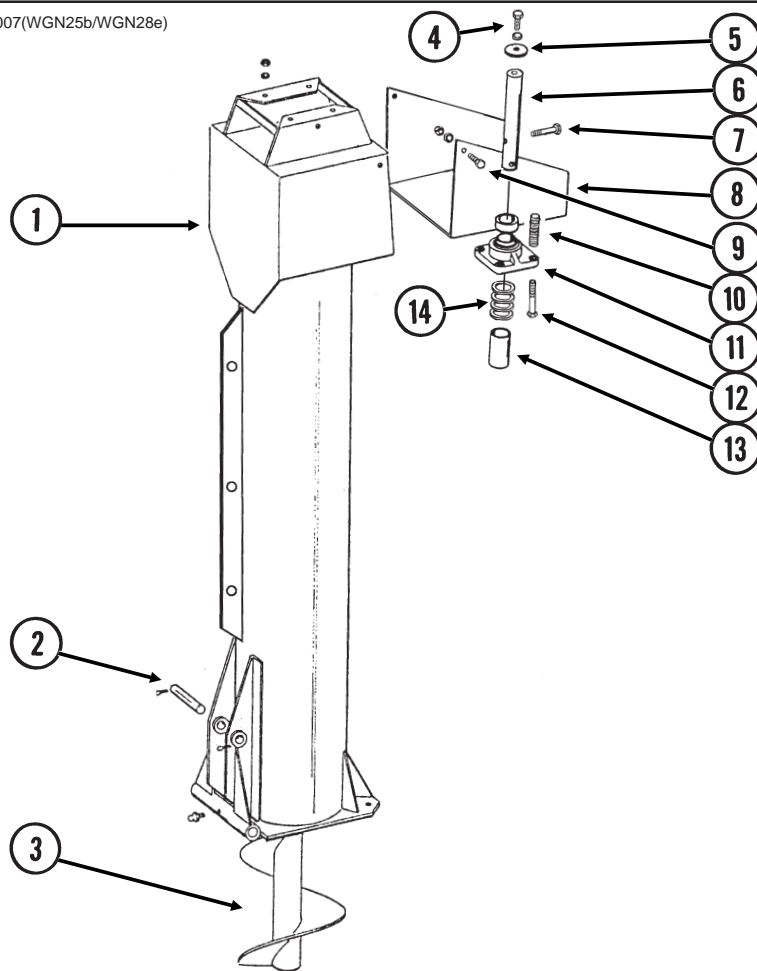

ITEM	PART NO.	QTY.	DESCRIPTION
1.	GR0966	1	Housing W/Grease Fitting
	G10641	-	Grease Fitting, 1/8" NPT
2.	GD2161	1	Pin, 1 1/4" x 8 1/4"
	G10460	2	Cotter Pin, 1/4" x 2"
3.	GA4534	1	Auger, Right Hand, 14" x 8'
4.	G10025	1	Hex Head Cap Screw, 3/4"-10 x 1 1/2"
	G10231	1	Lock Washer, 3/4"
5.	GD9592	1	Special Washer
6.	GD6388	1	Shaft, 2" x 14 3/4"
7.	G10013	2	Hex Head Cap Screw, 5/8"-11 x 3 1/2"
	G10107	2	Lock Nut, 5/8"-11
8.	GD6420	1	Extension
9.	G10001	2	Hex Head Cap Screw, 3/8"-16 x 1"
	G10108	2	Lock Nut, 3/8"-16
10.	GD6433	4	Spring
11.	GA0449	1	Bearing W/Lock Collar And Set Screw, 2"
	GR0265	-	Lock Collar ("FAFNIR" Stamped On Bearing)
	G10080	-	Hex Socket Set Screw, 7/16"-14 x 7/16" ("FAFNIR" Stamped On Bearing)
	GR1376	-	Lock Collar ("SKF" Stamped On Bearing)
	G10850	-	Hex Socket Set Screw, 7/16"-20 x 7/16" ("SKF" Stamped On Bearing)
	GR1434	-	Lock Collar ("INA" Stamped On Bearing)
	G10120	-	Hex Socket Set Screw, 3/8"-16 x 1/2" ("INA" Stamped On Bearing)
	GR1174	-	Lock Collar ("FYH" Stamped On Bearing)
	G10849	-	Hex Socket Set Screw, 3/8"-24 x 1/2" ("FYH" Stamped On Bearing)
12.	GD6462	4	Special Bolt, 5/8"-11 x 6"
	G10107	4	Lock Nut, 5/8"-11
13.	GD3457-06	1	Sleeve, 2" x 7 1/4" Long
14.	G10234	-	Machine Bushing, 2 1/8", 10 Gauge (As Required)
	G10892	-	Machine Bushing, 2 1/8", 18 Gauge (As Required)
15.	G1K303	1	Upper Vertical Auger Housing Liner Kit, 89 3/8" Long

# VERTICAL AUGER - UPPER SECTION

840/1040

WVA004/WVA010(WGN26c/WGN28e)

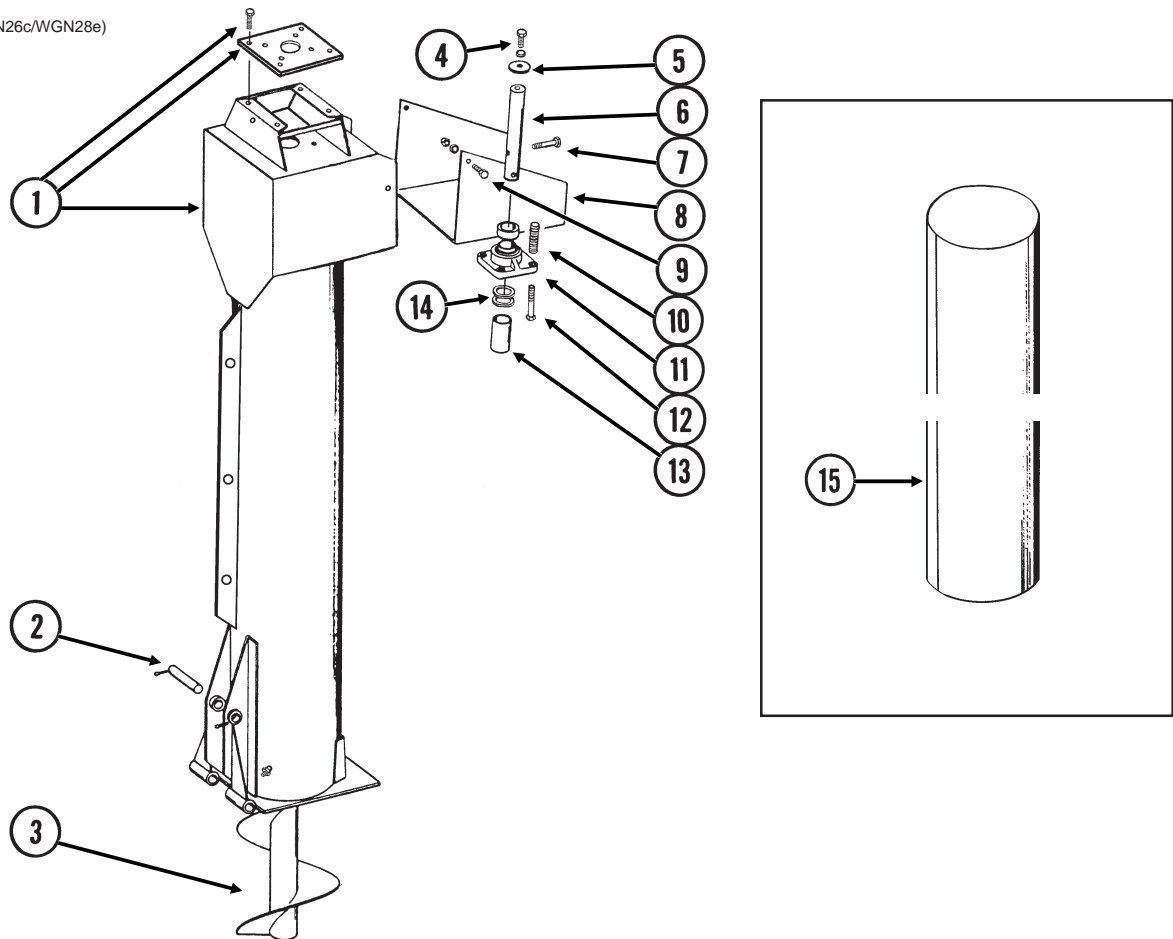

ITEM	PART NO.	QTY.	DESCRIPTION
1.	G1K297	1	Upper Vertical Auger Housing Kit W/Top Plate, Hardware And Grease Fittings
	GD11589	1	Top Plate
	G10107	4	Lock Nut, 5/8"-11
	G10942	4	Hex Head Tap Bolt, 5/8"-11 x 2 1/2"
2.	G10640	2	Grease Fitting, 1/4"-28
	GD0653	1	Pin, 1 1/4" x 7 3/4"
3.	G10460	2	Cotter Pin, 1/4" x 2"
	GA4538	1	Auger, Right Hand, 16" x 8'
4.	G10025	1	Hex Head Cap Screw, 3/4"-10 x 1 1/2"
	G10231	1	Lock Washer, 3/4"
5.	GD9592	1	Special Washer
6.	GD7069	1	Pin, 2 7/16" x 11 1/2"
7.	G10011	2	Hex Head Cap Screw, 5/8"-11 x 5 1/2"
	G10107	2	Lock Nut, 5/8"-11
8.	GD8017	1	Extension
9.	G10001	2	Hex Head Cap Screw, 3/8"-16 x 1"
	G10108	2	Lock Nut, 3/8"-16
10.	GD6433	4	Spring
11.	GA0448	1	Bearing W/Lock Collar And Set Screw, 2 7/16"
	GR0264	-	Lock Collar ("FAFNIR" Stamped On Bearing)
	G10080	-	Hex Socket Set Screw, 7/16"-14 x 7/16" ("FAFNIR" Stamped On Bearing)
	GR1326	-	Lock Collar ("SKF" Stamped On Bearing)
	G10850	-	Hex Socket Set Screw, 7/16"-20 x 7/16" ("SKF" Stamped On Bearing)
	GR1433	-	Lock Collar ("INA" Stamped On Bearing)
	G10072	-	Hex Socket Set Screw, 3/8"-16 x 3/8" ("INA" Stamped On Bearing)
	GR1325	-	Lock Collar ("FYH" Stamped On Bearing)
	G10849	-	Hex Socket Set Screw, 3/8"-24 x 1/2" ("FYH" Stamped On Bearing)
	12.	GD6462	4
13.	G10107	4	Lock Nut, 5/8"-11
	GD8038-04	-	Sleeve, 2 1/2" x 3" Long
14.	G10359	-	Machine Bushing, 2 1/2", 18 Gauge (As Required)
	G10360	-	Machine Bushing, 2 1/2", 10 Gauge (As Required)
15.	G1K304	1	Upper Vertical Auger Housing Liner Kit, 84" Long

# VERTICAL AUGER - LOWER SECTION

640

WVA008/WVA006(WGN127a/WGN127/WGN28e/WGN128)

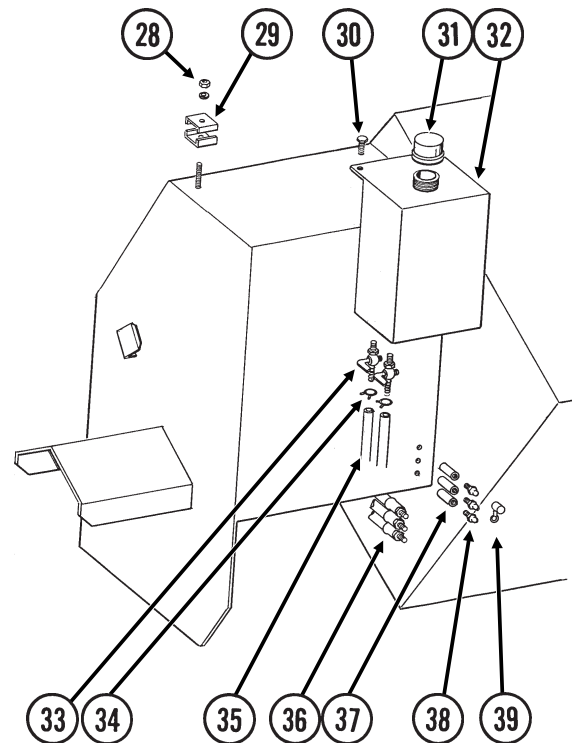
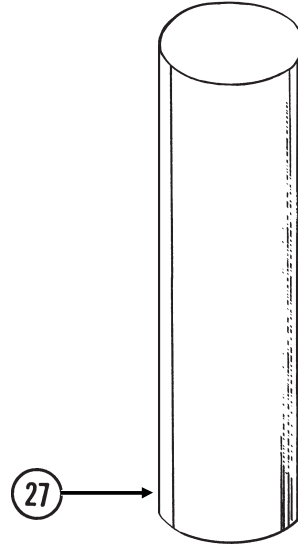
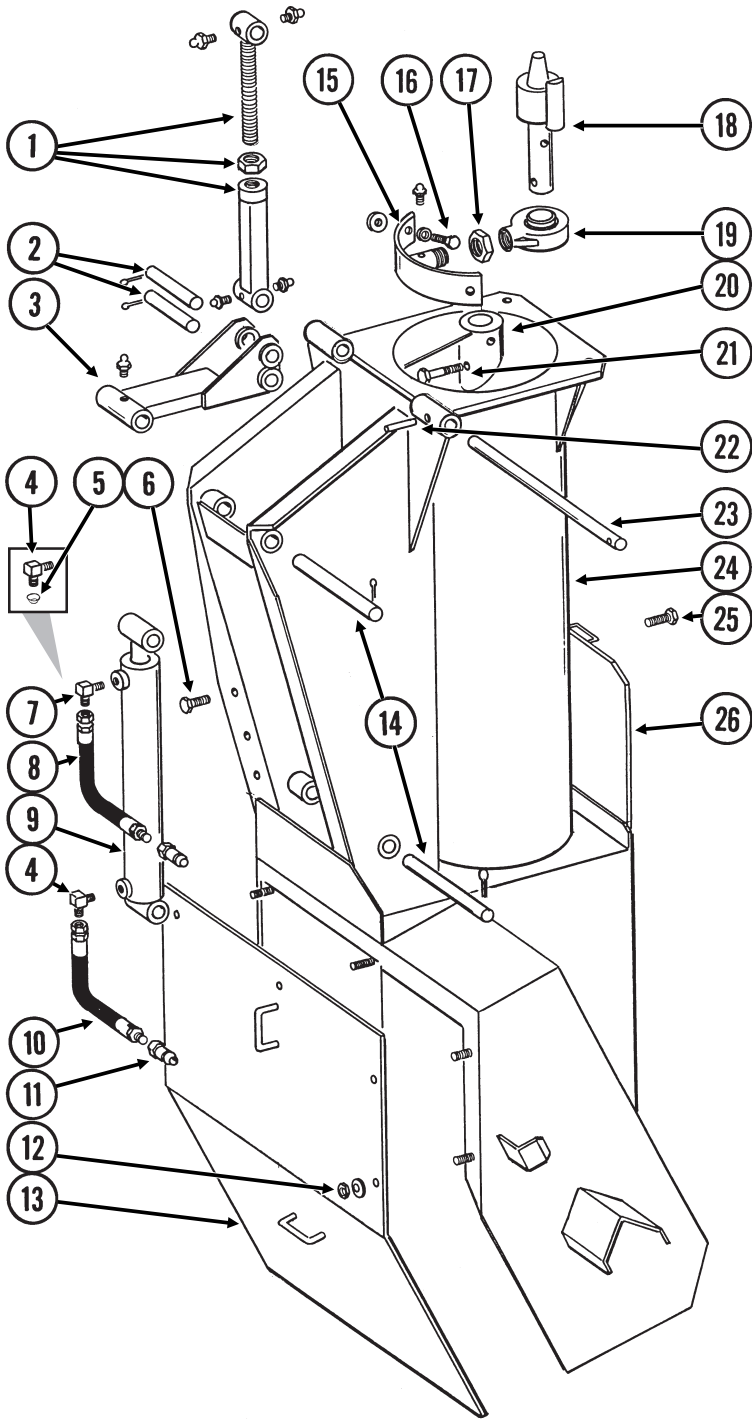

# VERTICAL AUGER - LOWER SECTION

640

ITEM	PART NO.	QTY.	DESCRIPTION
1.	GA4160	1	Fold Arm W/Grease Fittings And Jam Nut
	G10641	-	Grease Fitting, 1/8" NPT
	G10087	-	Jam Nut, 1 1/2"-12, Grade 2
2.	GD4108	2	Pin, 1 1/4" x 7"
	G10460	4	Cotter Pin, 1/4" x 2"
3.	GA4174	1	Folding Link W/Grease Fitting
	G10641	-	Grease Fitting, 1/8" NPT
4.	G6801-06-08	1-2	Elbow W/O-Ring, 90°, 9/16"-18 Male JIC To 3/4"-16 O-Ring
	GR1037	-	O-Ring
5.	GD6323	1	Restrictor ( <b>Sub GA8609</b> ), Item 7
6.	G10007	-	Hex Head Cap Screw, 5/8"-11 x 1 1/2" (L.H. Support Bracket When Viewed From Front Of Machine)
	G10230	-	Lock Washer, 5/8"
	G10104	-	Hex Nut, 5/8"-11
7.	GA8609	1	Flow Restrictor Elbow, 9/16"-18 JIC To 3/4"-16 O-Ring ("R" Stamped On Both Sides)
8.	*A1112	1	Hose Assembly, 1/4" x 138"
9.		-	See "Vertical Auger Fold Cylinder", Pages P43 And P44
10.	*A1111	1	Hose Assembly, 1/4" x 120"
11.	GD4086	2	ISO Coupler
12.	G10229	6	Lock Washer, 3/8"
	G10101	6	Hex Nut, 3/8"-16
13.	GA4208	1	Inspection Cover
14.	GD4014	2	Pin, 1 1/4" x 12"
	G10460	4	Cotter Pin, 1/4" x 2"
15.	GR0965	1	Bearing Hanger W/Grease Fitting
	G10641	-	Grease Fitting, 1/8" NPT
16.	G10008	2	Hex Head Cap Screw, 5/8"-11 x 2"
	G10217	4	Washer, 5/8" USS
	G10230	2	Lock Washer, 5/8"
	G10104	2	Hex Nut, 5/8"-11
17.	GD10748	1	Special Nut, 1"-11
18.	GA4163	1	Bullet
19.	GA0451	1	Hanger Bearing, 2"
20.	GA4535	1	Auger, Right Hand, 14" x 6' 1"
21.	G10013	2	Hex Head Cap Screw, 5/8"-11 x 3 1/2"
	G10107	2	Lock Nut, 5/8"-11
22.	G10610	1	Spring Pin, 3/8" x 2"
23.	GD6417	1	Shaft, 1 1/4" x 17"
24.	GR0967	1	Housing (Prior To Serial No. 503739)
	GR1556	-	Housing (Serial No. 503739 And On)
25.	G10017	2	Hex Head Cap Screw, 1/2"-13 x 1 1/2" (R.H. Support Bracket When Viewed From Front Of Wagon)
	G10228	2	Lock Washer, 1/2"
	G10102	2	Hex Nut, 1/2"-13
26.	GA4168	1	Cleanout Door
27.	G1K200	-	Lower Vertical Auger Housing Liner Kit, 56 7/8" Long (Prior To Serial No. 503739)
28.	G10232	1	Lock Washer, 5/16"
	G10106	1	Hex Nut, 5/16"-18
29.	GD5892	-	Hose Clamp, 5/8" x 1 1/2" x 1 1/2"
30.	G10019	3	Hex Head Cap Screw, 5/16"-18 x 1"
	G10232	3	Lock Washer, 5/16"
	G10219	3	Washer, 5/16" USS
	G10106	3	Hex Nut, 5/16"-18
31.	GA4112	1	Vented Cap, 1 1/2" NPT
32.	GA4189	1	Tank
33.	GA4110	2	Hose Cock, Brass
34.	G10426	2	Wire Hose Clamp, 5/8"
35.	GD6279-04	-	Clear Plastic Hose, 9/16" x 17"
36.	GA0504	3	Grease Hose, 24"
37.	G10125	3	Pipe Coupling, 1/8" NPT
38.	G10763	3	Grease Fitting, Extended, 1/8"-27
39.	G10434	3	Cap Plug

\*Hydraulic hose is not stocked by KINZE® Repair Parts, but can be made available on a special order basis. Call for quote.

# VERTICAL AUGER - LOWER SECTION

840/1040

WVA001/WVA011(WGN127a/WGN129/WGN28e/WGN130)

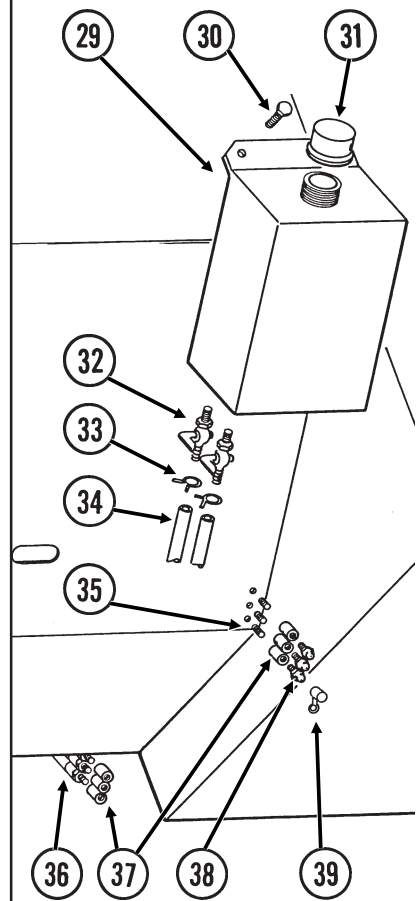
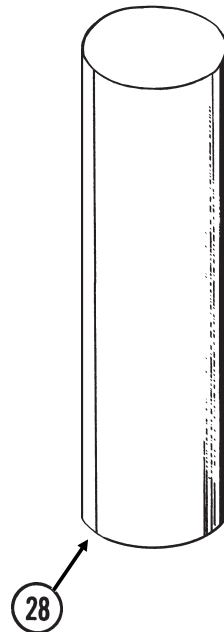
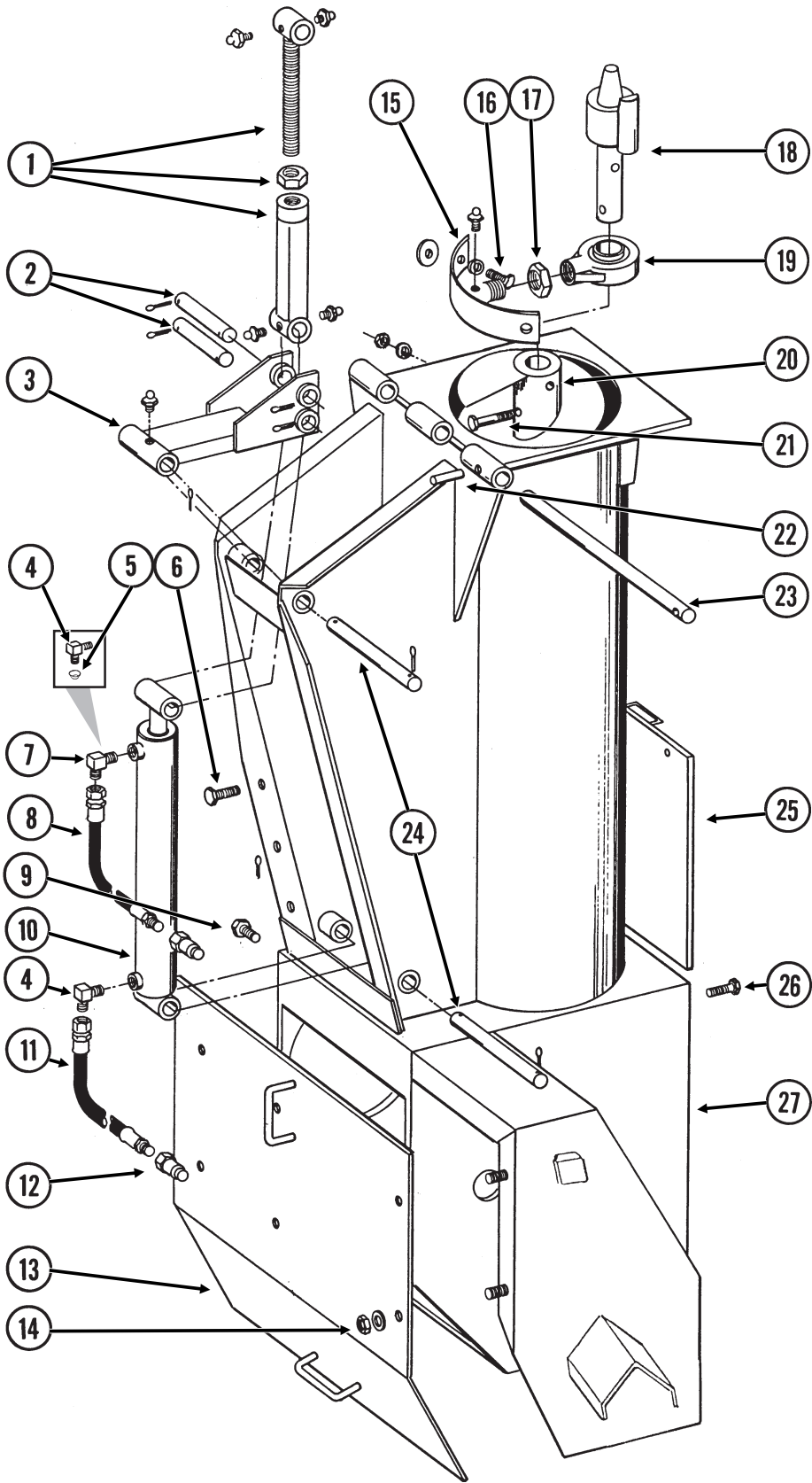

# VERTICAL AUGER - LOWER SECTION

840/1040

ITEM	PART NO.	QTY.	DESCRIPTION
1.	GA4160	1	Fold Arm W/Grease Fittings And Jam Nut
	G10641	-	Grease Fitting, 1/8" NPT
	G10087	-	Jam Nut, 1 1/2"-12, Grade 2
2.	GD4108	2	Pin, 1 1/4" x 7"
	G10460	4	Cotter Pin, 1/4" x 2"
3.	GA4174	1	Folding Link W/Grease Fitting
	G10641	-	Grease Fitting, 1/8" NPT
4.	G6801-08	1-2	Elbow W/O-Ring, 90°, 3/4"-16 Male JIC To O-Ring
	GR1037	-	O-Ring
5.	GD6323	-	Restrictor (Sub GA8610), Item 7
6.	G10007	-	Hex Head Cap Screw, 5/8"-11 x 1 1/2" (L.H. Support Bracket When Viewed From Front Of Wagon)
	G10230	-	Lock Washer, 5/8"
	G10104	-	Hex Nut, 5/8"-11
7.	GA8610	1	Flow Restrictor Elbow, 3/4"-16 JIC To 3/4"-16 O-Ring ("R" Stamped On Both Sides)
8.	*A1015	1	Hose Assembly, 3/8" x 138"
9.	G10025	-	Hex Head Cap Screw, 3/4"-10 x 1 1/2"
	G10231	-	Lock Washer, 3/4"
	G10105	-	Hex Nut, 3/4"-10
10.		-	See "Vertical Auger Fold Cylinder", Pages P43 And P44
11.	*A1014	1	Hose Assembly, 3/8" x 120"
12.	GD4086	2	ISO Coupler
13.	GA5769	1	Inspection Cover
14.	G10229	6	Lock Washer, 3/8"
	G10101	6	Hex Nut, 3/8"-16
15.	GA0511	1	Mount W/Grease Fitting
	G10641	-	Grease Fitting, 1/8" NPT
16.	G10016	2	Hex Head Cap Screw, 1/2"-13 x 2"
	G10216	4	Washer, 1/2" USS
	G10111	2	Lock Nut, 1/2"-13
17.	GD10749	1	Special Nut, 1 1/4"-11
18.	GA0423	1	Bullet
19.	GA0452	1	Bearing, 2 7/16"
20.	GA4539	1	Auger, Right Hand, 16" x 5' 6"
21.	G10011	2	Hex Head Cap Screw, 5/8"-11 x 5 1/2"
	G10107	2	Lock Nut, 5/8"-11
22.	G10610	1	Spring Pin, 3/8" x 2"
23.	GD4012	1	Shaft, 1 1/4" x 22 3/4"
24.	GD4014	2	Pin, 1 1/4" x 12"
	G10460	4	Cotter Pin, 1/4" x 2"
25.	GA5773	1	Cleanout Door
26.	G10017	2	Hex Head Cap Screw, 1/2"-13 x 1 1/2" (R.H. Support Bracket When Viewed From Front Of Wagon)
	G10228	2	Lock Washer, 1/2"
	G10102	2	Hex Nut, 1/2"-13
27.	G1K278	1	Housing (Prior To Serial No. 503739)
	G1K326	-	Housing (Serial No. 503739 And On)
28.	G1K201	-	Lower Vertical Auger Housing Liner Kit, 53 1/2" Long (Prior To Serial No. 503739)
29.	GA4108	1	Tank
30.	G10019	2	Hex Head Cap Screw, 5/16"-18 x 1"
	G10232	2	Lock Washer, 5/16"
	G10219	2	Washer, 5/16" USS
	G10106	2	Hex Nut, 5/16"-18
31.	GA4112	1	Vented Cap, 1 1/2" NPT
32.	GA4110	2	Hose Cock, Brass
33.	G10426	2	Wire Hose Clamp, 5/8"
34.	GD6279-04	-	Clear Plastic Hose, 9/16" x 17"
35.	G10127	3	Pipe Nipple, 1/8" NPT x 1 1/2" Long
36.	GA0504	3	Grease Hose, 24"
37.	G10125	3	Pipe Coupling, 1/8" NPT
38.	G10763	3	Grease Fitting, Extended, 1/8"-27
39.	G10434	3	Cap Plug

\*Hydraulic hose is not stocked by KINZE® Repair Parts, but can be made available on a special order basis. Call for quote.



WAD005/WAD002(WGN29b)

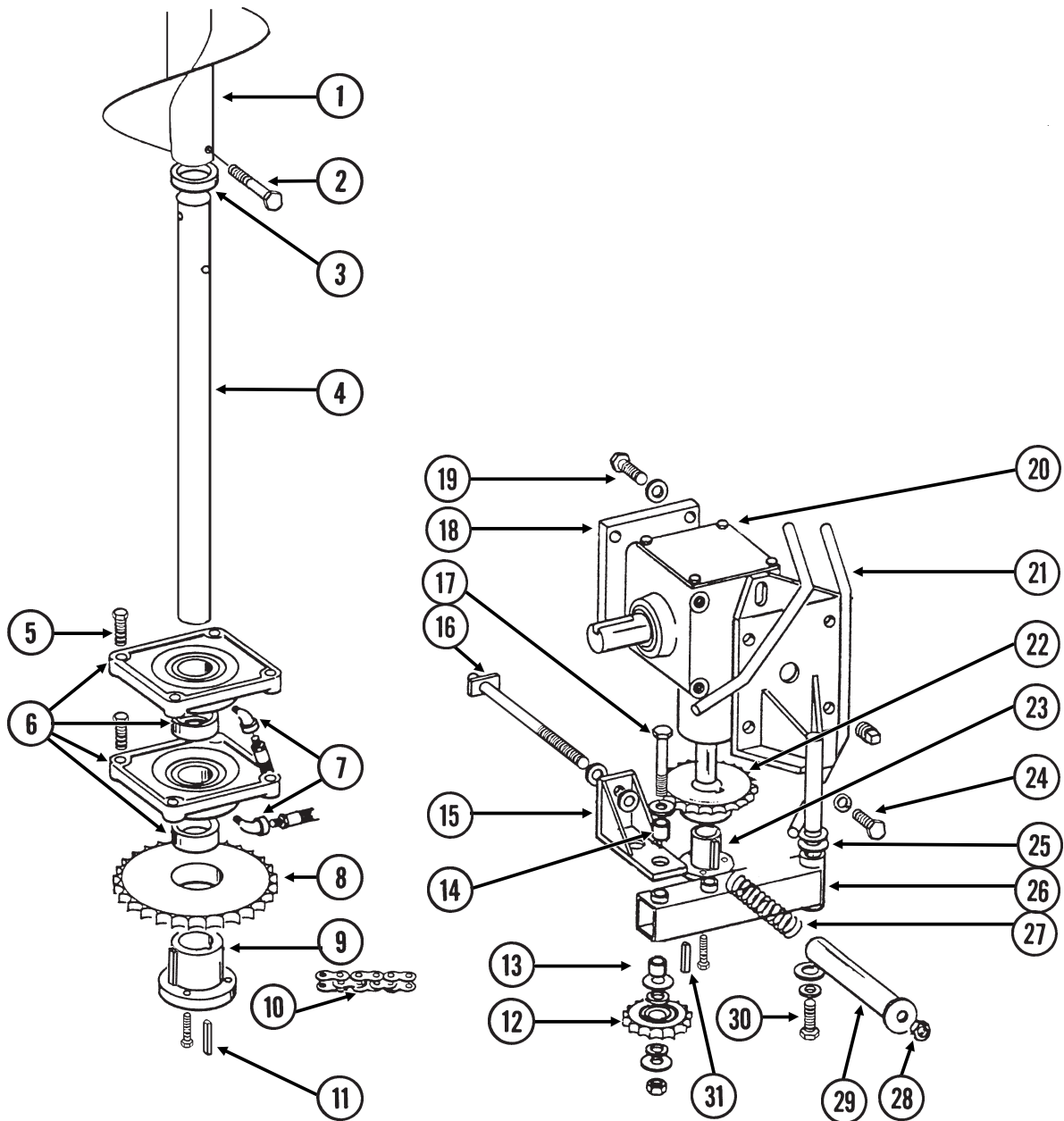

ITEM	PART NO.	QTY.	DESCRIPTION
1.		-	See "Vertical Auger/Lower Section, 640", Pages P14 And P15
2.	G10013	2	Hex Head Cap Screw, 5/8"-11 x 3 1/2"
	G10107	2	Lock Nut, 5/8"-11
3.	GD3457-04	1	Sleeve, 2" x 1 3/8" Long
4.	GD6387	1	Shaft, 2" x 20"
5.	G10008	8	Hex Head Cap Screw, 5/8"-11 x 2"
	G10230	8	Lock Washer, 5/8"
	G10104	8	Hex Nut, 5/8"-11
6.	GA0449	1	Bearing W/Lock Collar And Set Screw, 2"
	GR0265	-	Lock Collar ("FAFNIR" Stamped On Bearing)
	G10080	-	Hex Socket Set Screw, 7/16"-14 x 7/16" ("FAFNIR" Stamped On Bearing)
	GR1376	-	Lock Collar ("SKF" Stamped On Bearing)
	G10850	-	Hex Socket Set Screw, 7/16"-20 x 7/16" ("SKF" Stamped On Bearing)
	GR1434	-	Lock Collar ("INA" Stamped On Bearing)
	G10120	-	Hex Socket Set Screw, 3/8"-16 x 1/2" ("INA" Stamped On Bearing)
	GR1174	-	Lock Collar ("FYH" Stamped On Bearing)
	G10849	-	Hex Socket Set Screw, 3/8"-24 x 1/2" ("FYH" Stamped On Bearing)
7.	G10423	2	Elbow, 90°, 1/8" Male NPT To Female
	G10914	-	Adapter, 1/8" Male NPT To Female (As Required Between G10423 And Bearing)
8.	GD4117	1	Sprocket, 26 Tooth
9.	GA0713	1	Bushing W/Hex Head Cap Screws And Set Screw, 2"
	G10004	-	Hex Head Cap Screw, 3/8"-16 x 1 1/4"
	G10141	-	Hex Socket Head Set Screw, 1/4"-20 x 3/4"
10.	G3304-63	1	Chain, No. 80, 63 Pitch Including Connector Link And Offset Link
	GR0197	-	Connector Link, No. 80
	GR0202	-	Offset Link, No. 80
11.	GD0148	1	Key, 1/2" x 1/2" x 2 1/2"
12.	GD4119	1	Idler Sprocket W/Bearing, 12 Tooth
	GA0593	-	Bearing
13.	GD6425-03	1	Bushing, 1" O.D. x 3/4" I.D. x 3/8" Long
14.	GD6425-01	1	Bushing, 1" O.D. x 3/4" I.D. x 1/2" Long
15.	GA4691	1	Bracket
16.	GA4178	1	Idler Bracket
	G10217	1	Washer, 5/8" USS
17.	G10058	1	Hex Head Cap Screw, 3/4"-10 x 5 1/2"
	G10215	5	Machine Bushing, 3/4", 14 Gauge
	G10218	3	Washer, 3/4" USS
	G10112	1	Lock Nut, 3/4"-10
18.	GD6408	1	Spacer
19.	G10039	4	Hex Head Cap Screw, 1/2"-13 x 1 3/4"
	G10228	4	Lock Washer, 1/2"
20.		-	See "Gearbox, 640", Page P10
21.	GA4734	1	Idler Plate
22.	GD4118	1	Sprocket, 15 Tooth
23.	GD4121	1	Bushing W/Hex Head Cap Screws, 1 1/4"
	G10019	-	Hex Head Cap Screw, 5/16"-16 x 1"
24.	G10014	4	Hex Head Cap Screw, 1/2"-13 x 1"
	G10228	4	Lock Washer, 1/2"
25.	G10233	-	Machine Bushing, 1", 10 Gauge (As Required)
	G10526	-	Machine Bushing, 1" (.048" Thick) (As Required)
26.	GA4690	1	Arm W/Grease Fitting
	G10641	-	Grease Fitting, 1/8" NPT
27.	GD6337	1	Spring
28.	G10730	1	Nylon Lock Nut, 5/8"-11
29.	GA4180	1	Spring Housing
30.	G10438	1	Hex Head Cap Screw, 1/2"-13 x 3/4"
	G10228	1	Lock Washer, 1/2"
	G10216	1	Washer, 1/2" USS
31.	GD0147	1	Key, 1/4" x 1/4" x 2"

# VERTICAL AUGER DRIVE

840/1040

WAD002/WAD006(WGN30f)

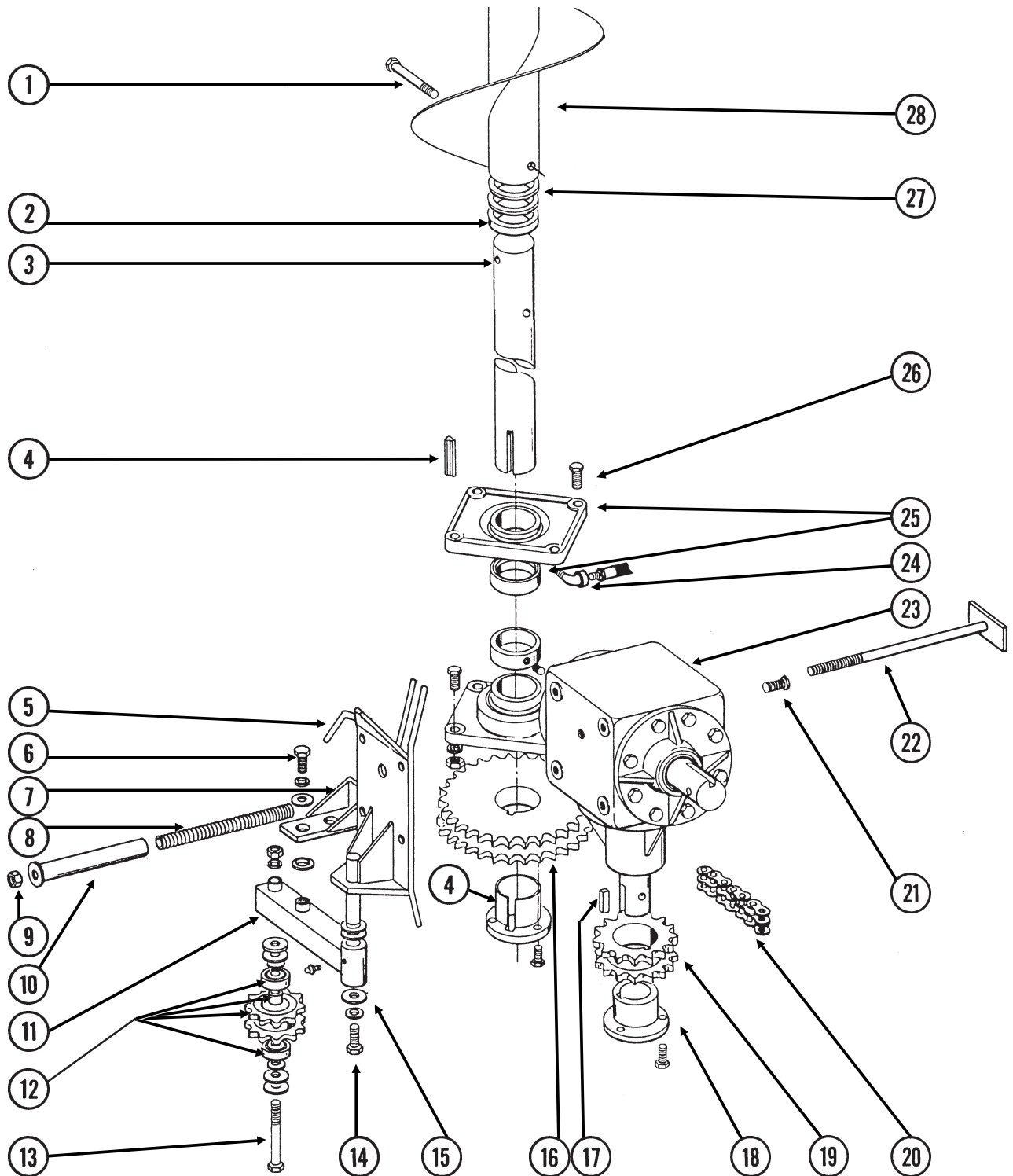

ITEM	PART NO.	QTY.	DESCRIPTION	
1.	G10011	2	Hex Head Cap Screw, 5/8"-11 x 5 1/2"	
	G10107	2	Lock Nut, 5/8"-11	
2.	GD8038-05	1	Sleeve, 2 1/2" x 1 1/2" Long	
3.	GD6885	1	Shaft, 2 7/16" x 22"	
4.	GD1358	1	Bushing W/Hex Head Cap Screws And Key, 2 7/16"	
	GR0258	-	Offset Key	
	G10004	-	Hex Head Cap Screw, 3/8"-16 x 1 1/4"	
5.	GA4692	1	Idler Plate	
6.	G10543	1	Hex Head Adjusting Bolt, 3/4"-10 x 3"	
	G10231	1	Lock Washer, 3/4"	
	G10218	2	Washer, 3/4" USS	
7.	GA4691	1	Bracket	
8.	GD6337	1	Spring	
9.	G10730	1	Nylon Lock Nut, 5/8"-11	
10.	GA4180	1	Spring Housing	
11.	GA4690	1	Arm W/Grease Fitting	
	G10641	-	Grease Fitting, 1/8" NPT	
12.	GA0447	1	Idler Sprocket W/Spacer And Bearings	
	GR0259	-	Spacer, 1 3/4" O.D. (As Required)	
	GR1248	-	Spacer, 1" O.D. (As Required)	
	GA0593	-	Bearing	
13.	G10058	1	Hex Head Cap Screw, 3/4"-10 x 5 1/2"	
	G10215	5	Machine Bushing, 3/4", 14 Gauge	
	G10218	3	Washer, 3/4" USS	
	G10112	1	Lock Nut, 3/4"-10	
14.	G10438	1	Hex Head Cap Screw, 1/2"-13 x 3/4"	
	G10228	1	Lock Washer, 1/2"	
	G10216	1	Washer, 1/2" USS	
15.	G10233	-	Machine Bushing, 1", 10 Gauge (As Required)	
	G10526	-	Machine Bushing, 1" (.048" Thick) (As Required)	
16.	GD1357	1	Sprocket, 30 Tooth	
17.	GD9221	-	Key, 3/8" x 3/8" x 1 7/8"	
18.	GD4079	1	Bushing W/Hex Head Cap Screws, 1 3/4"	
	G10004	-	Hex Head Cap Screw, 3/8"-16 x 1 1/4"	
19.	GD4077	1	Sprocket, 16 Tooth	
20.	G3301-65	1	Chain, No. 80-2, 65 Pitch Including Connector Link And Offset Link	
	GR0206	-	Offset Link, No. 80-2	
	GR0198	-	Connector Link, No. 80-2	
	G10055	4	Hex Head Cap Screw, 5/8"-11 x 1 1/4"	
	GA4178	1	Idler Bracket	
21.	G10423	2	Elbow, 90°, 1/8" Male NPT To Female	
22.	G10914	-	Adapter, 1/8" Male NPT To Female (As Required Between G10423 And Bearing)	
	GA0448	1	Bearing W/Lock Collar And Set Screw, 2 7/16"	
25.	GR0264	-	Lock Collar ("FAFNIR" Stamped On Bearing)	
	G10080	-	Hex Socket Set Screw, 7/16"-14 x 7/16" ("FAFNIR" Stamped On Bearing)	
	GR1326	-	Lock Collar ("SKF" Stamped On Bearing)	
	G10850	-	Hex Socket Set Screw, 7/16"-20 x 7/16" ("SKF" Stamped On Bearing)	
	GR1433	-	Lock Collar ("INA" Stamped On Bearing)	
	G10072	-	Hex Socket Set Screw, 3/8"-16 x 3/8" ("INA" Stamped On Bearing)	
	GR1325	-	Lock Collar ("FYH" Stamped On Bearing)	
	G10849	-	Hex Socket Set Screw, 3/8"-24 x 1/2" ("FYH" Stamped On Bearing)	
	26.	G10008	8	Hex Head Cap Screw, 5/8"-11 x 2"
		G10230	8	Lock Washer, 5/8"
G10104		8	Hex Nut, 5/8"-11	
G10359		-	Machine Bushing, 2 1/2", 18 Gauge (As Required)	
27.	G10360	-	Machine Bushing, 2 1/2", 10 Gauge (As Required)	
		-	See "Vertical Auger, Lower Section, 840/1040", Pages P16 And P17	

WAD004(WGN31b)

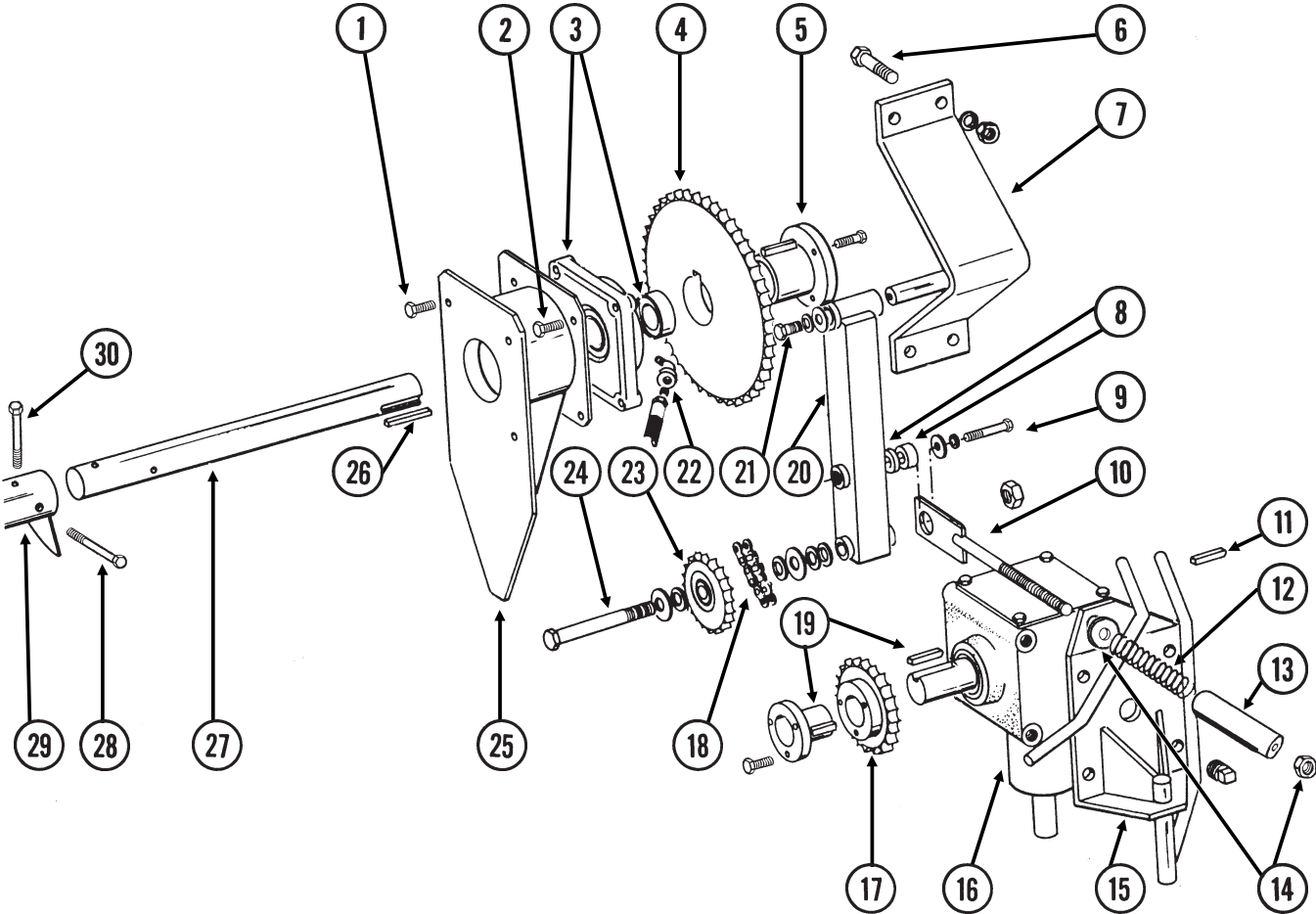

ITEM	PART NO.	QTY.	DESCRIPTION
1.	G10055	4	Hex Head Cap Screw, 5/8"-11 x 1 1/4"
	G10230	4	Lock Washer, 5/8"
	G10104	4	Hex Nut, 5/8"-11
2.	G10005	4	Hex Head Cap Screw, 5/8"-11 x 1 3/4"
	G10230	4	Lock Washer, 5/8"
	G10104	4	Hex Nut, 5/8"-11
3.	GA0449	1	Bearing W/Lock Collar And Set Screw, 2"
	GR0265	-	Lock Collar ("FAFNIR" Stamped On Bearing)
	G10080	-	Hex Socket Set Screw, 7/16"-14 x 7/16" ("FAFNIR" Stamped On Bearing)
	GR1376	-	Lock Collar ("SKF" Stamped On Bearing)
	G10850	-	Hex Socket Set Screw, 7/16"-20 x 7/16" ("SKF" Stamped On Bearing)
	GR1434	-	Lock Collar ("INA" Stamped On Bearing)
	G10120	-	Hex Socket Set Screw, 3/8"-16 x 1/2" ("INA" Stamped On Bearing)
	GR1174	-	Lock Collar ("FYH" Stamped On Bearing)
	G10849	-	Hex Socket Set Screw, 3/8"-24 x 1/2" ("FYH" Stamped On Bearing)
4.	GD6392	1	Sprocket, 34 Tooth
5.	GD4123	1	Bushing W/Hex Head Cap Screws, 2"
	G10004	-	Hex Head Cap Screw, 3/8"-16 x 1 1/4"
6.	G10017	4	Hex Head Cap Screw, 1/2"-13 x 1 1/2"
	G10228	4	Lock Washer, 1/2"
	G10102	4	Hex Nut, 1/2"-13
7.	GA4182	1	Upper Mounting Plate
8.	GD6425-01	2	Bushing, 1" O.D. x 3/4" I.D. x 1/2" Long
9.	G10028	1	Hex Head Cap Screw, 3/4"-10 x 3"
	G10215	1	Machine Bushing, 3/4", 14 Gauge
	G10218	1	Washer, 3/4" USS
10.	GA4177	1	Idler Bar
11.			See "PTO Assembly", Pages P2-P5
12.	GD6337	1	Spring
13.	GA4180	1	Spring Housing
14.	G10205	1	Washer, 5/8" SAE
	G10730	1	Nylon Lock Nut, 5/8"-11
15.		-	See "Vertical Auger Drive, 640", Pages P18 And P19
16.		-	See "Gearbox, 640", Page P10
17.	GD4118	1	Sprocket, 15 Tooth
18.	G3304-51	1	Chain, No. 80, 51 Pitch Including Connector Link And Offset Link
	GR0197	-	Connector Link, No. 80
	GR0202	-	Offset Link, No. 80
	GD4120	1	Bushing W/Hex Head Cap Screws And Key, 1 1/2"
19.	G10019	-	Hex Head Cap Screw, 5/16"-16 x 1"
	GR0361	-	Key
	GA4690	1	Arm W/Grease Fitting
20.	G10641	-	Grease Fitting, 1/8" NPT
	G10438	1	Hex Head Cap Screw, 1/2"-13 x 3/4"
21.	G10228	1	Lock Washer, 1/2"
	G10216	1	Washer, 1/2" USS
	G10423	1	Elbow, 90°, 1/8" Male NPT To Female
22.	G10914	-	Adapter, 1/8" Male NPT To Female (As Required Between G10423 And Bearing)
	GD4119	1	Idler Sprocket W/Bearing, 12 Tooth
23.	GA0531	-	Inner Bearing
	G10058	1	Hex Head Cap Screw, 3/4"-10 x 5 1/2"
24.	G10215	5	Machine Bushing, 3/4", 14 Gauge
	G10218	3	Washer, 3/4" USS
	G10112	1	Lock Nut, 3/4"-10
	GA4171	1	Bearing Spacer
25.	GD0148	1	Key, 1/2" x 1/2" x 2 1/2"
26.	GD1346	1	Shaft, 2" x 18 1/2"
27.	G10013	1	Hex Head Cap Screw, 5/8"-11 x 3 1/2"
	G10107	1	Lock Nut, 5/8"-11
28.		-	See "Horizontal Augers And Bearings, 640", Page P26
29.	G10743	1	Hex Head Cap Screw, 5/8"-11 x 3 3/4"
	G10107	1	Lock Nut, 5/8"-11



# HORIZONTAL AUGER DRIVE

840/1040

WAD003/WAD006WHA002(WGN32a)

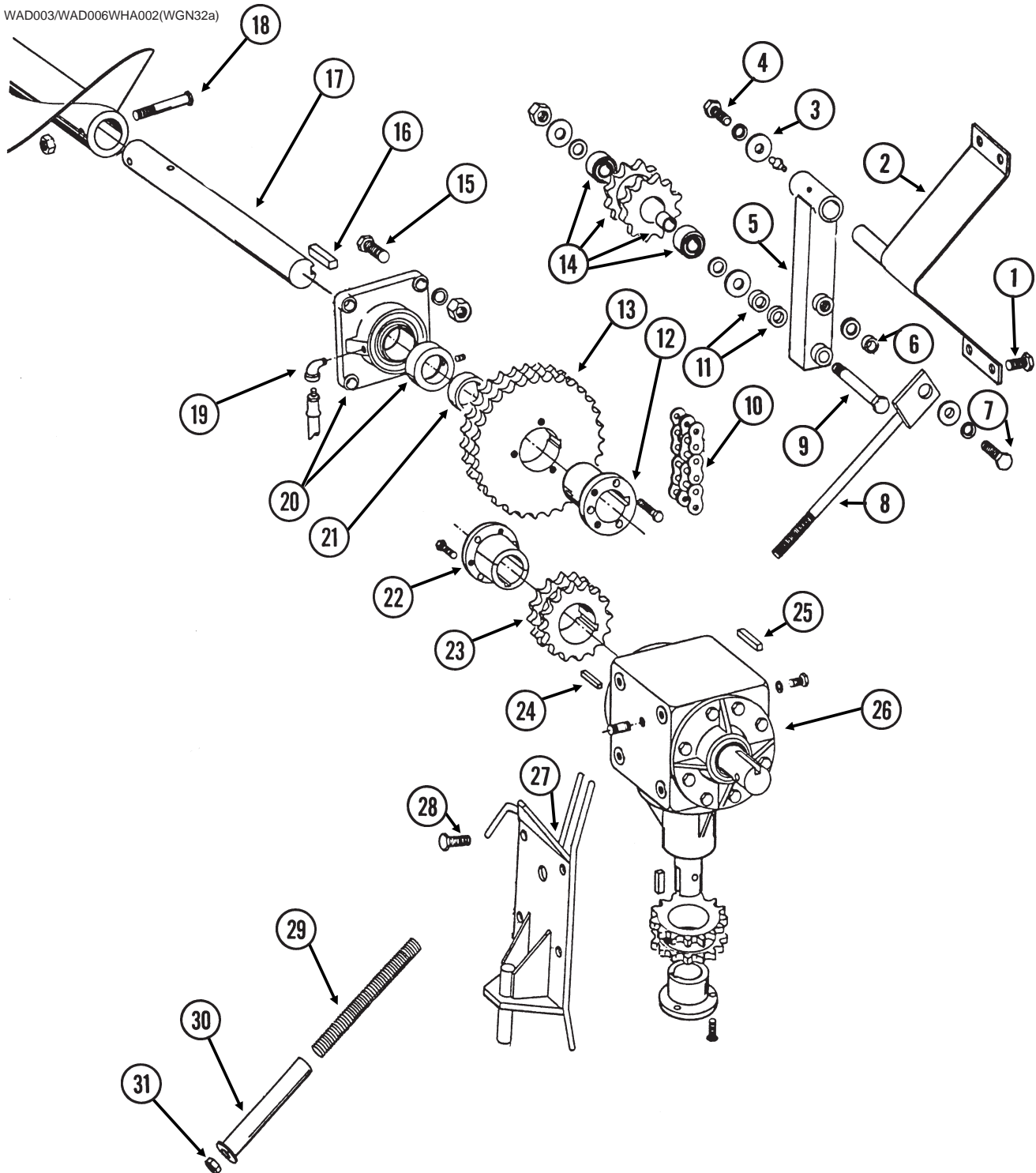

ITEM	PART NO.	QTY.	DESCRIPTION
1.	G10017	4	Hex Head Cap Screw, 1/2"-13 x 1 1/2"
	G10228	4	Lock Washer, 1/2"
	G10102	4	Hex Nut, 1/2"-13
	2.	GA4182	1
3.	G10233	-	Machine Bushing, 1", 10 Gauge (As Required)
	G10526	-	Machine Bushing, 1" (.048" Thick) (As Required)

# HORIZONTAL AUGER DRIVE

840/1040

ITEM	PART NO.	QTY.	DESCRIPTION	
4.	G10438	1	Hex Head Cap Screw, 1/2"-13 x 3/4"	
	G10228	1	Lock Washer, 1/2"	
	G10216	1	Washer, 1/2" USS	
5.	GA4690	1	Arm W/Grease Fitting	
	G10641	-	Grease Fitting, 1/8" NPT	
6.	GD6425-01	1	Bushing, 1" O.D. x 3/4" I.D. x 1/2" Long	
7.	G10543	1	Hex Head Adjusting Bolt, 3/4"-10 x 3"	
	G10231	1	Lock Washer, 3/4"	
	G10218	1	Washer, 3/4" USS	
8.	GA4177	1	Idler Bar	
9.	G10400	1	Hex Head Cap Screw, 3/4"-10 x 6 1/2"	
	G10215	2	Machine Bushing, 3/4", 14 Gauge	
	G10218	2	Washer, 3/4" USS	
	G10112	1	Lock Nut, 3/4"-10	
10.	G3301-45	1	Chain, No. 80-2, 45 Pitch Including Connector Link And Offset Link (Used W/26 Tooth Sprocket, Item 13)	
	G3301-47	-	Chain, No. 80-2, 47 Pitch Including Connector Link And Offset Link (Used W/30 Tooth Sprocket, Item 13)	
	GR0198	-	Connector Link, No. 80-2	
	GR0206	-	Offset Link, No. 80-2	
	11.	GD2951	3	Sleeve, 25/32" x 3/8" Long
	12.	GD4123	1	Bushing W/Hex Head Cap Screws, 2"
G10004		-	Hex Head Cap Screw, 3/8"-16 x 1 1/4"	
13.	GD9820	1	Sprocket, 26 Tooth	
	GD1357	1	Sprocket, 30 Tooth	
14.	GA0447	1	Idler Sprocket W/Spacer And Bearings	
	GA0593	-	Bearing	
	GR0259	-	Spacer, 1 3/4" O.D. (As Required)	
	GR1248	-	Spacer, 1" O.D. (As Required)	
15.	G10009	4	Hex Head Cap Screw, 5/8"-11 x 2 1/2"	
	G10217	4	Washer, 5/8" USS	
	G10230	4	Lock Washer, 5/8"	
	G10104	4	Hex Nut, 5/8"-11	
16.	GD0148	1	Key, 1/2" x 1/2" x 2 1/2"	
17.	GD9821	1	Shaft, 2" x 12 1/2"	
18.	G10318	2	Hex Head Cap Screw, 5/8"-11 x 4 1/2"	
	G10230	1	Lock Washer, 5/8" (Under Cap Screw Head On Rear Auger)	
	G10107	2	Lock Nut, 5/8"-11	
19.	G10423	1	Elbow, 90°, 1/8" Male NPT To Female	
	G10914	-	Adapter, 1/8" Male NPT To Female (As Required Between G10423 And Bearing)	
20.	GA0449	1	Bearing W/Lock Collar And Set Screw, 2"	
	GR0265	-	Lock Collar ("FAFNIR" Stamped On Bearing)	
	G10080	-	Hex Socket Set Screw, 7/16"-14 x 7/16" ("FAFNIR" Stamped On Bearing)	
	GR1376	-	Lock Collar ("SKF" Stamped On Bearing)	
	G10850	-	Hex Socket Set Screw, 7/16"-20 x 7/16" ("SKF" Stamped On Bearing)	
	GR1434	-	Lock Collar ("INA" Stamped On Bearing)	
	G10120	-	Hex Socket Set Screw, 3/8"-16 x 1/2" ("INA" Stamped On Bearing)	
	GR1174	-	Lock Collar ("FYH" Stamped On Bearing)	
21.	G10849	-	Hex Socket Set Screw, 3/8"-24 x 1/2" ("FYH" Stamped On Bearing)	
	GD4016	1	Spacer, 2" x 1/2" Wide	
22.	GD4079	1	Bushing W/Hex Head Cap Screws, 1 3/4"	
	G10004	-	Hex Head Cap Screw, 3/8"-16 x 1 1/4"	
23.	GD4077	1	Sprocket, 16 Tooth	
24.	GD9221	1	Key, 3/8" x 3/8" x 1 7/8"	
25.		-	See "PTO Assembly", Pages P6-P9	
26.		-	See "Gearbox, 840/1040", Page P11	
27.		-	See "Vertical Auger Drive, 840/1040", Pages P20 And P21	
28.	G10055	4	Hex Head Cap Screw, 5/8"-11 x 1 1/4"	
29.	GD6337	1	Spring	
30.	GA4180	1	Spring Housing	
31.	G10730	1	Nylon Lock Nut, 5/8"-11	

WHA003/WHA004(WGN53a)

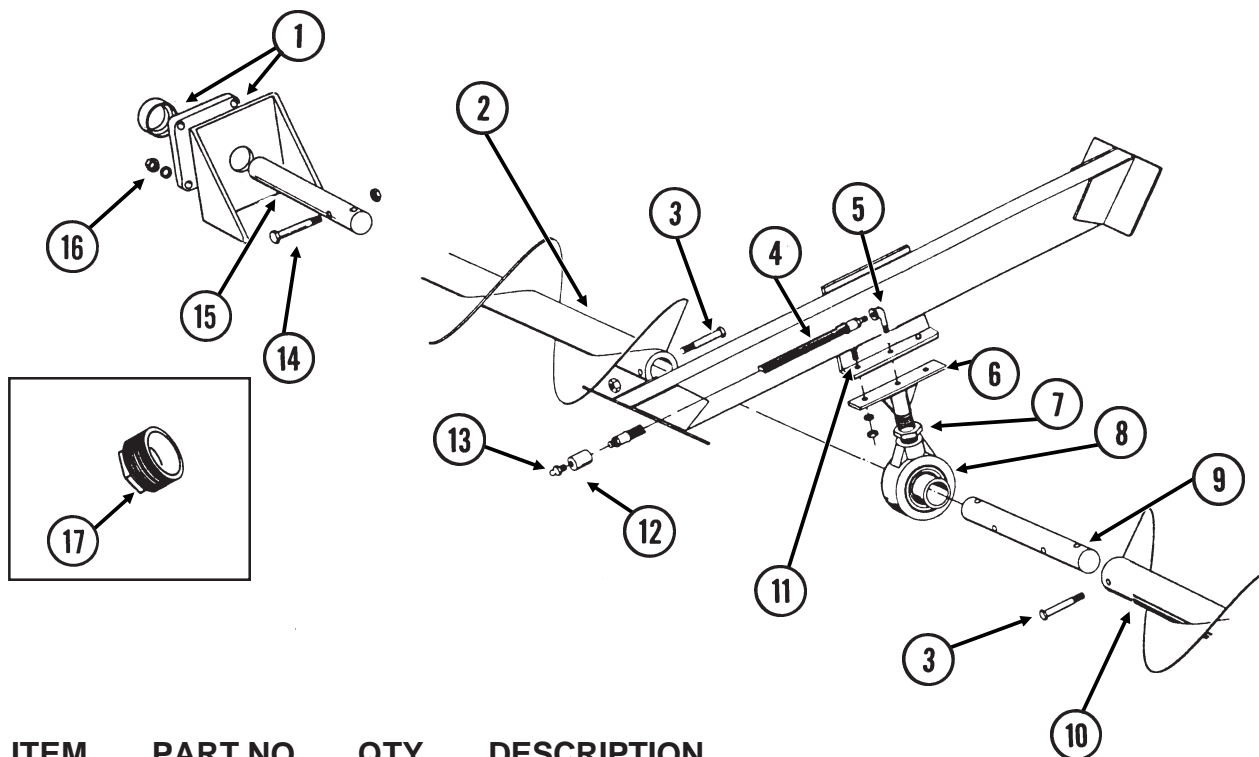

ITEM	PART NO.	QTY.	DESCRIPTION
1.	GA0450	1	Bearing W/Lock Collar And Set Screw, 1 1/2"
	GR0266	-	Lock Collar ("FAFNIR" Stamped On Bearing)
	G10072	-	Hex Socket Set Screw, 3/8"-16 x 3/8" ("FAFNIR" Stamped On Bearing)
	GR1324	-	Lock Collar ("SKF" Stamped On Bearing)
	G10694	-	Hex Socket Set Screw, 3/8"-24 x 3/8" ("SKF" Stamped On Bearing)
	GR1324	-	Lock Collar ("MANKO" Stamped On Bearing)
	G10694	-	Hex Socket Set Screw, 3/8"- 24 x 3/8" ("MANKO" Stamped On Bearing)
	GR1323	-	Lock Collar ("FYH" Stamped On Bearing)
	G10847	-	Hex Socket Set Screw, 5/16"-24 x 3/8" ("FYH" Stamped On Bearing)
2.	GA4533	1	Rear Auger, Left Hand, 12" x 6'
3.	G10036	4	Hex Head Cap Screw, 5/8"-11 x 4"
	G10107	4	Lock Nut, 5/8"-11
4.	GA0504	1	Grease Hose, 24"
5.	G10423	1	Elbow, 90°, 1/8" Male NPT To Female
6.	GA4147	1	Bracket
7.	GD10748	1	Special Nut, 1"-11
8.	GA0451	1	Hanger Bearing, 2"
9.	GD4010	1	Shaft, 2" x 13 1/2"
10.	GA4532	1	Front Auger, Left Hand, 12" x 7' 2 1/2"
11.	G10039	2	Hex Head Cap Screw, 1/2"-13 x 1 3/4"
	G10228	2	Lock Washer, 1/2"
	G10102	2	Hex Nut, 1/2"-13
12.	G10125	1	Pipe Coupling, 1/8" NPT
13.	G10641	1	Grease Fitting, 1/8" NPT
14.	G10033	2	Hex Head Cap Screw, 1/2"-13 x 3 1/2"
	G10111	2	Lock Nut, 1/2"-13
15.	GD1447	1	Shaft, 1 1/2" x 16 1/2"
16.	G10228	4	Lock Washer, 1/2"
	G10102	4	Hex Nut, 1/2"-13
17.	G10185	1	Pipe Plug, 2" NPT (Located In Bottom Of Wagon)

# HORIZONTAL AUGERS AND BEARINGS

840/1040

WHA002/WHA004/WTC011(WGN33a)

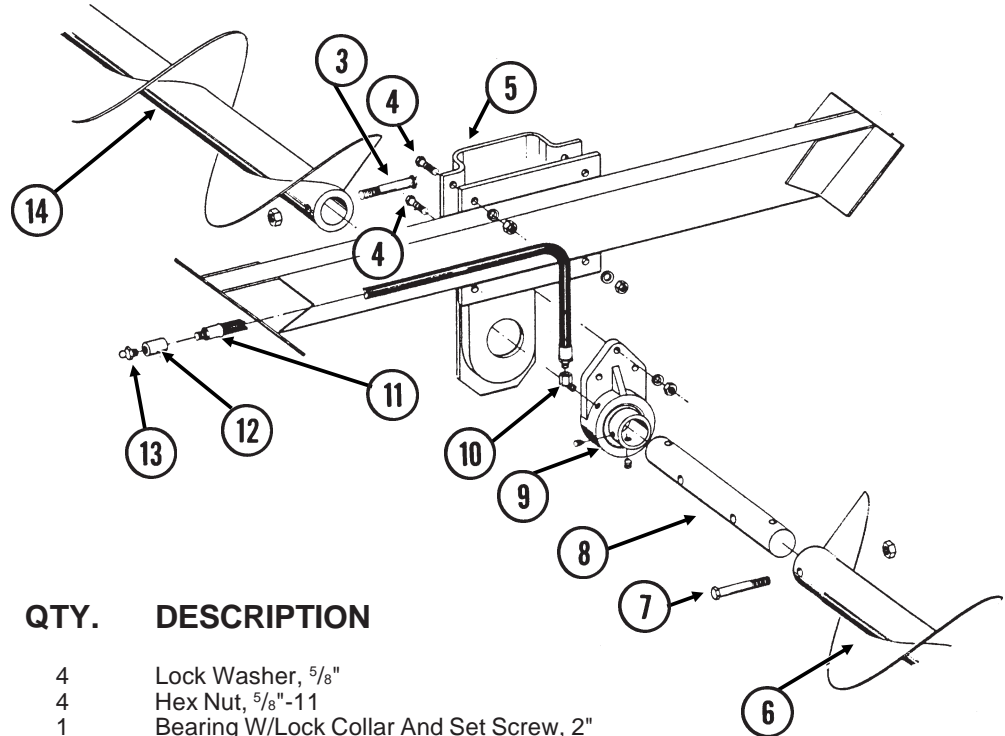
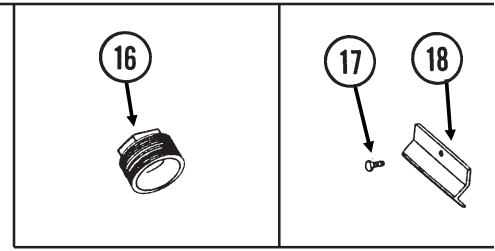
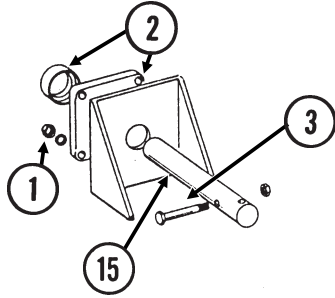

ITEM	PART NO.	QTY.	DESCRIPTION
1.	G10230	4	Lock Washer, 5/8"
	G10104	4	Hex Nut, 5/8"-11
2.	GA0449	1	Bearing W/Lock Collar And Set Screw, 2"
	GR0265	-	Lock Collar ("FAFNIR" Stamped On Bearing)
	G10080	-	Hex Socket Set Screw, 7/16"-14 x 7/16" ("FAFNIR" Stamped On Bearing)
	GR1376	-	Lock Collar ("SKF" Stamped On Bearing)
	G10850	-	Hex Socket Set Screw, 7/16"-20 x 7/16" ("SKF" Stamped On Bearing)
	GR1434	-	Lock Collar ("INA" Stamped On Bearing)
	G10120	-	Hex Socket Set Screw, 3/8"-16 x 1/2" ("INA" Stamped On Bearing)
	GR1174	-	Lock Collar ("FYH" Stamped On Bearing)
	G10849	-	Hex Socket Set Screw, 3/8"-24 x 1/2" ("FYH" Stamped On Bearing)
3.	G10036	4	Hex Head Cap Screw, 5/8"-11 x 4"
	G10107	4	Lock Nut, 5/8"-11
4.	G10017	4	Hex Head Cap Screw, 1/2"-13 x 1 1/2"
	G10228	4	Lock Washer, 1/2"
	G10102	4	Hex Nut, 1/2"-13
5.	GA0685	1	Bracket
6.	GA6919	1	Front Auger, Left Hand, 12" x 11' 8"
7.	G10318	2	Hex Head Cap Screw, 5/8"-11 x 4 1/2"
	G10107	2	Lock Nut, 5/8"-11
8.	GD4010	1	Shaft, 2" x 13 1/2"
9.	GA0517	1	Hanger Bearing, 2"
10.	G5503-02-02	1	Elbow, 45°, 1/8" NPT
11.	GA0504	1	Grease Hose, 24", Wheel And Sof-Trak/UTC Wagons
	GA5852	-	Grease Hose, 48", Row Crop Wagons
12.	G10125	1	Pipe Coupling, 1/8" NPT
13.	G10641	1	Grease Fitting, 1/8" NPT
14.	GA4537	1	Rear Auger, Left Hand, 12" x 8'
15.	GD1347	1	Shaft, 2" x 13"
	G10185	1	Pipe Plug, 2" NPT (Located In Bottom Of Wagon)
17.	G10001	-	Hex Head Cap Screw, 3/8"-16 x 1"
	G10229	-	Lock Washer, 3/8"
	G10101	-	Hex Nut, 3/8"-16
18.	GD8219	-	Grease Hose Hold Down, Row Crop Wagons Only

WTC003/WTC006(WGN135/WGN133)

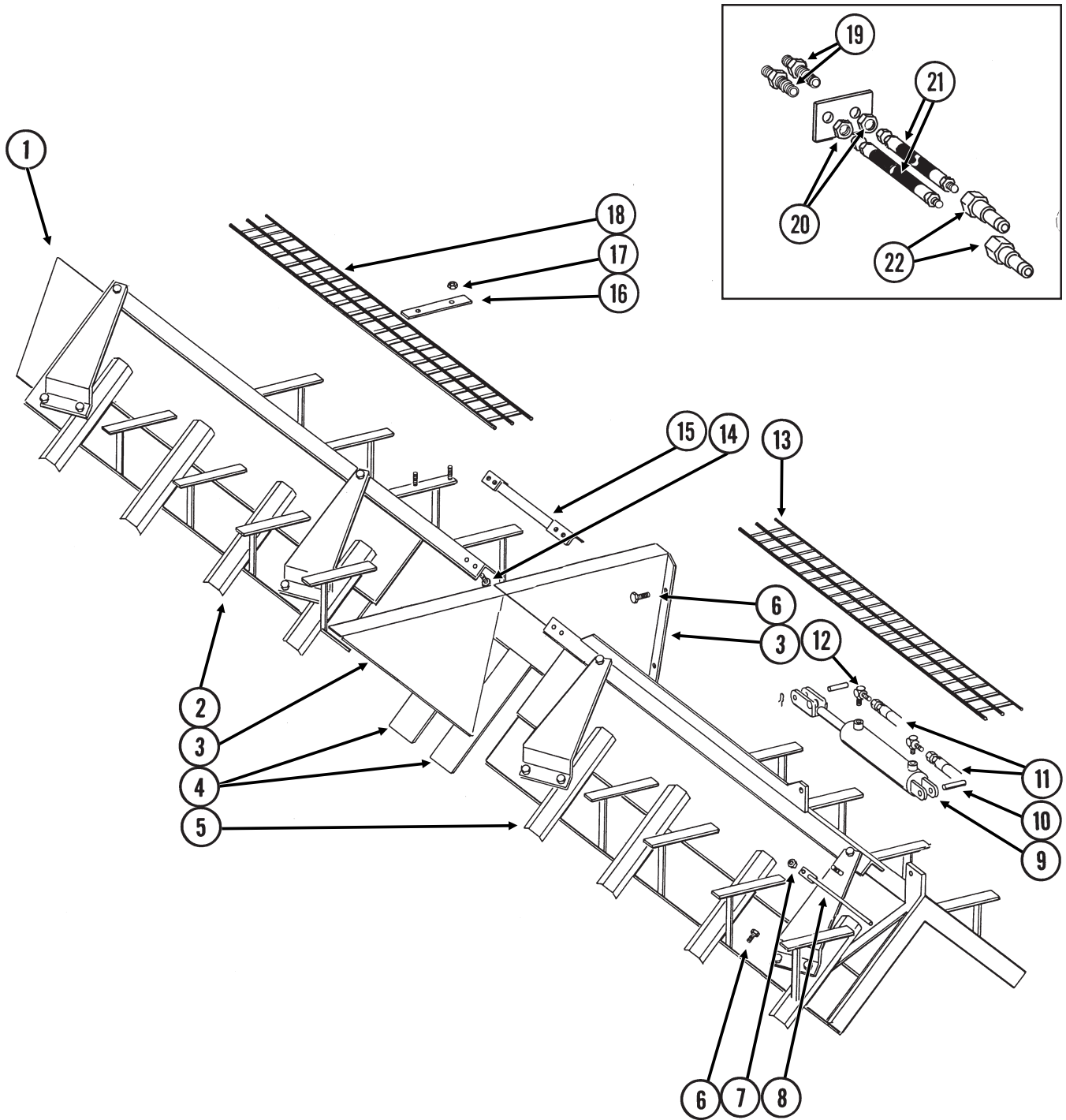

ITEM	PART NO.	QTY.	DESCRIPTION
1.	GD6307	1	Cap
2.	GA4134	1	Rear Tunnel Cover Assembly
3.	GD6308	2	Bearing Cover
4.	GD6309	1	Plate, 6"
	GD6985	1	Plate, 7"
5.	GA4135	1	Front Tunnel Cover Assembly
6.	G10004	32	Hex Head Cap Screw, $\frac{3}{8}$ "-16 x 1 $\frac{1}{4}$ "
	G10229	32	Lock Washer, $\frac{3}{8}$ "
	G10101	32	Hex Nut, $\frac{3}{8}$ "-16
7.	G10111	1	Lock Nut, $\frac{1}{2}$ "-13
8.	GA4085	1	Sight Gauge Rod
9.		-	See "Grain Flow Control Cylinder, 640", Pages P45 And P46
10.	GR0962	2	Pin, 1" x 3 $\frac{3}{8}$ "
	GR0193	4	Hair Pin Clip
11.	*A1137	2	Hose Assembly, $\frac{1}{4}$ " x 23"
12.	G6801-06-08	2	Elbow W/O-Ring, 90°, $\frac{9}{16}$ "-18 Male JIC To $\frac{3}{4}$ "-16 O-Ring
	GR1037	-	O-Ring
13.	GA4185	2	Front Screen, 66"
14.	G10017	8	Hex Head Cap Screw, $\frac{1}{2}$ "-13 x 1 $\frac{1}{2}$ "
	G10228	8	Lock Washer, $\frac{1}{2}$ "
	G10102	8	Hex Nut, $\frac{1}{2}$ "-13
15.	GD10500	1	Tie
16.	GD6447	12	Clamp
17.	G10108	24	Lock Nut, $\frac{3}{8}$ "-16
18.	GA4186	2	Rear Screen, 78"
19.	G2700-06-06	2	Bulkhead Tube Union, $\frac{9}{16}$ "-18 Male JIC
20.	G306-06	2	Lock Nut, $\frac{9}{16}$ "-18
21.	*A1111	2	Hose Assembly, $\frac{1}{4}$ " x 120"
22.	GD4086	2	ISO Coupler

\*Hydraulic hose is not stocked by KINZE® Repair Parts, but can be made available on a special order basis. Call for quote.



# GRAIN FLOW CONTROL GATE

840/1040

WTC007/WTC011(WGN132/WGN131/WGN133)

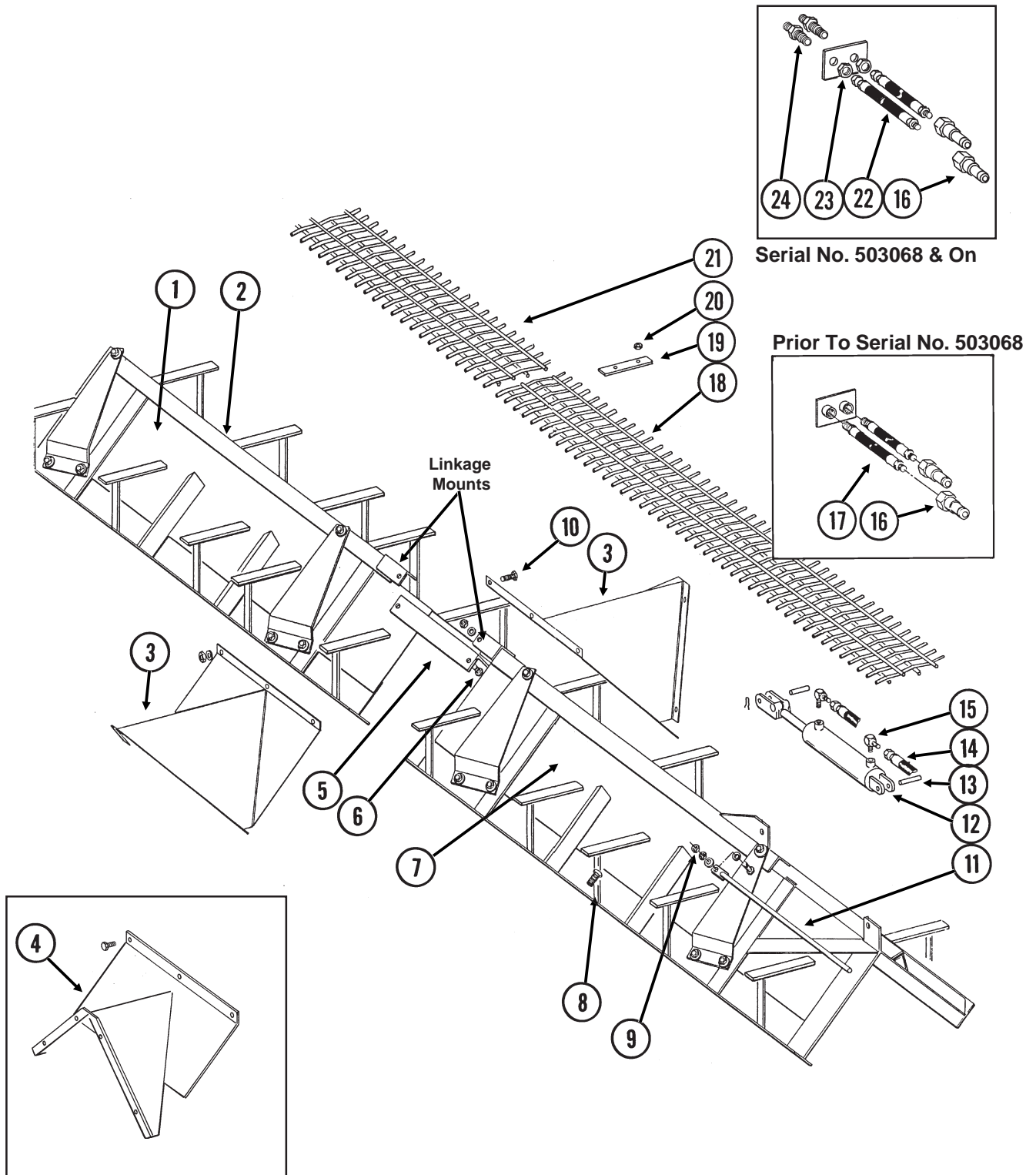

# GRAIN FLOW CONTROL GATE

840/1040

ITEM	PART NO.	QTY.	DESCRIPTION
1.	GA4719	1	Rear Tunnel Cover Assembly (Includes Item 2 Less Linkage Mount), Wheel And Sof-Trak/UTC Wagons (Shown)
	GA5860	-	Rear Tunnel Cover Assembly (Includes Item 2 Less Linkage Mount), Row Crop Wagons
2.	GA1539	2	Linkage Arm
3.	GA0696	2	Bearing Cover, Wheel And Sof-Trak/UTC Wagons
4.	GA5813	2	Bearing Cover, Row Crop Wagons Only
5.	GD4061	1	Connector Arm
6.	G10025	4	Hex Head Cap Screw, $\frac{3}{4}$ "-10 x 1 $\frac{1}{2}$ "
	G10231	4	Lock Washer, $\frac{3}{4}$ "
	G10105	4	Hex Nut, $\frac{3}{4}$ "-10
7.	GA4718	1	Front Tunnel Cover Assembly (Includes Item 2 Less Linkage Mount), Wheel And Sof-Trak/UTC Wagons (Shown)
	GA5859	-	Front Tunnel Cover Assembly (Includes Item 2 Less Linkage Mount), Row Crop Wagons
8.	G10003	34	Hex Head Cap Screw, $\frac{3}{8}$ "-16 x 1 $\frac{1}{2}$ "
	G10210	68	Washer, $\frac{3}{8}$ " USS
	G10229	34	Lock Washer, $\frac{3}{8}$ "
	G10101	34	Hex Nut, $\frac{3}{8}$ "-16
9.	G10111	1	Lock Nut, $\frac{1}{2}$ "-13
10.	G10004	11	Hex Head Cap Screw, $\frac{3}{8}$ "-16 x 1 $\frac{1}{4}$ "
	G10229	11	Lock Washer, $\frac{3}{8}$ "
	G10101	11	Hex Nut, $\frac{3}{8}$ "-16
11.	GA0686	1	Rod
12.		-	See "Grain Flow Control Gate Cylinder, 840/1040", Pages P46 And P47
13.	GR0962	2	Pin, 1" x 3 $\frac{3}{8}$ "
	GR0193	4	Hair Pin Clip
14.	*A1017	2	Hose Assembly, $\frac{3}{8}$ " x 24" (Male To Female), Prior To Serial No. 503068
	*A1079	-	Hose Assembly, $\frac{3}{8}$ " x 24" (Female To Female), Serial No. 503068 & On
15.	G6801-08	2	Elbow W/O-Ring, 90°, $\frac{3}{4}$ "-16 Male JIC To O-Ring
	GR1037	-	O-Ring
16.	GD4086	2	ISO Coupler
17.	*A1016	2	Hose Assembly, $\frac{3}{8}$ " x 120"
18.	GA4697	1	Right Front Screen, 108", Wheel And Sof-Trak/UTC Wagons (Shown)
	GA8193	-	Left Front Screen, 108" With Cut Outs, Wheel And Sof-Trak/UTC Wagons
	GA5857	-	Right Front Screen, 108", Row Crop Wagons
	GA8192	-	Left Front Screen, 108" With Cut Outs, Row Crop Wagons
19.	GD7071	8	Clamp, 1" x 10 $\frac{1}{2}$ "
	GD8221	2	Clamp, 1" x 5 $\frac{1}{4}$ ", Row Crop Wagons Only
20.	G10108	16	Lock Nut, $\frac{3}{8}$ "-16
21.	GA4698	2	Rear Screen, 96", Wheel And Sof-Trak/UTC Wagons (Shown)
	GA5858	-	Rear Screen, 96", Row Crop Wagons
22.	*A1014	2	Hose Assembly, $\frac{3}{8}$ " x 120"
23.	G306-08	2	Lock Nut, $\frac{3}{4}$ "-16
24.	G2700-08	2	Bulkhead Tube Union, $\frac{3}{4}$ "-16 Male JIC

\*Hydraulic hose is not stocked by KINZE® Repair Parts, but can be made available on a special order basis. Call for quote.

WTP003/WTP008(WGN36a/WGN36b)

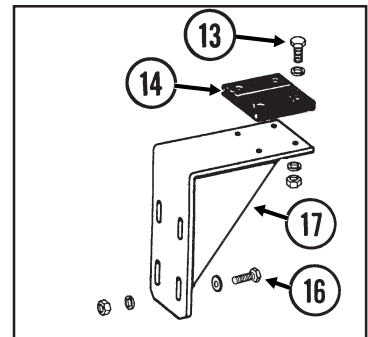
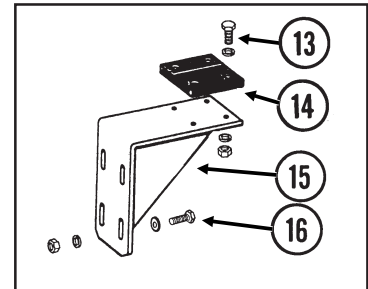
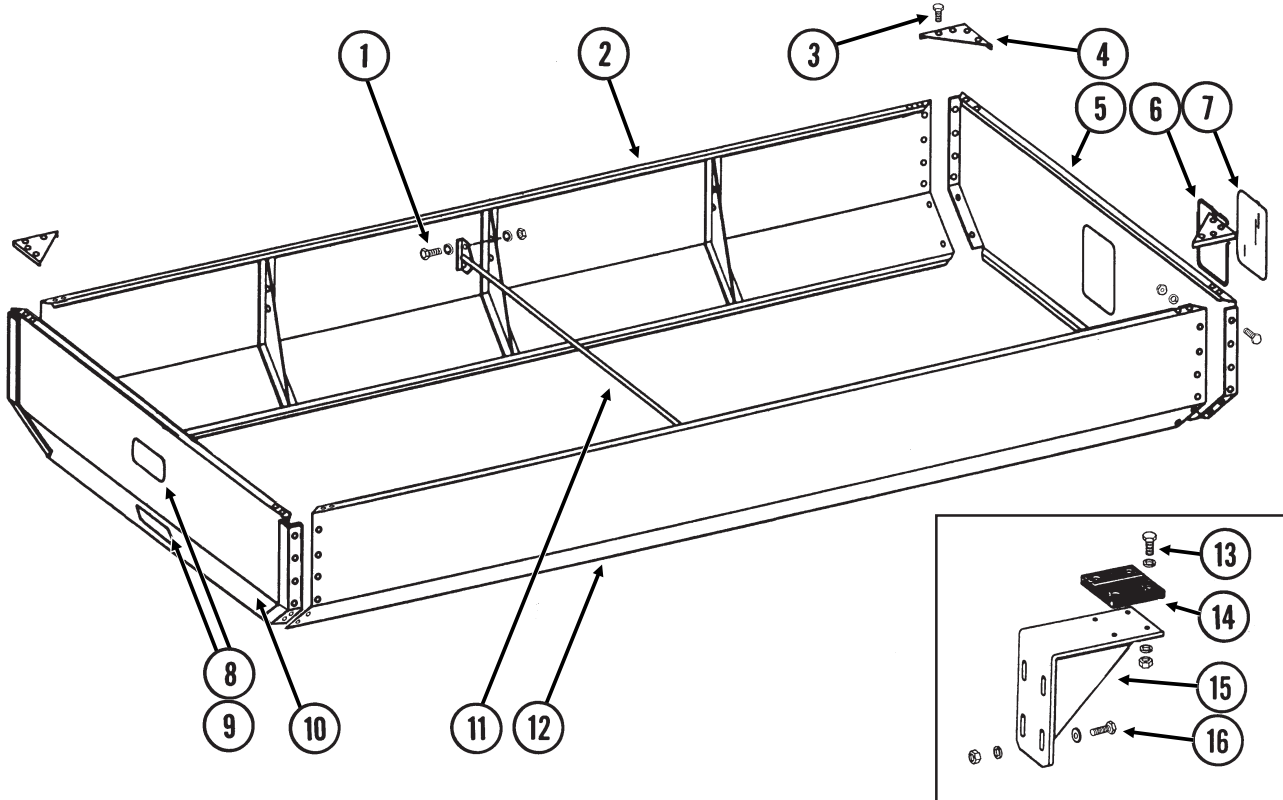

ITEM	PART NO.	QTY.	DESCRIPTION
1.	G10017	-	Hex Head Cap Screw, 1/2"-13 x 1 1/2"
	G10216	-	Washer, 1/2" USS
	G10228	-	Lock Washer, 1/2"
	G10102	-	Hex Nut, 1/2"-13
2.	GA4155	1	Side Panel, L.H.
3.	G10001	16	Hex Head Cap Screw, 3/8"-16 x 1"
	G10229	16	Lock Washer, 3/8"
	G10101	16	Hex Nut, 3/8"-16
4.	GD0327	4	Corner Cap
5.	GA4152	1	Front Panel
6.	GD6461-02	1	Front Window Molding
7.	GD6487	1	Front Window, 10 1/2" x 19 1/4"
8.	GD6460	2	Rear Window, 6 1/2" x 10 1/2"
9.	GD6461-01	2	Rear Window Molding
10.	GA4151	1	Rear Panel
11.	GA4688	3	Cross Brace, 119"
12.	GA4156	1	Side Panel, R.H.
13.	G10003	4	Hex Head Cap Screw, 3/8"-16 x 1 1/2"
	G10210	4	Washer, 3/8" USS
	G10229	4	Lock Washer, 3/8"
	G10101	4	Hex Nut, 3/8"-16
14.	GD6978	1	Rubber Stop
15.	GA4664	1	Adjustable Stop Bracket
16.	G10017	4	Hex Head Cap Screw, 1/2"-13 x 1 1/2"
	G10228	4	Lock Washer, 1/2"
	G10216	4	Washer, 1/2" USS
	G10102	4	Hex Nut, 1/2"-13
17.	GA8936	-	Adjustable Stop Bracket

# GRAIN TANK PANELS

# 840/1040

WTP004/WTP008/WAC019(WGN37c/WGN37e/WGN37d)

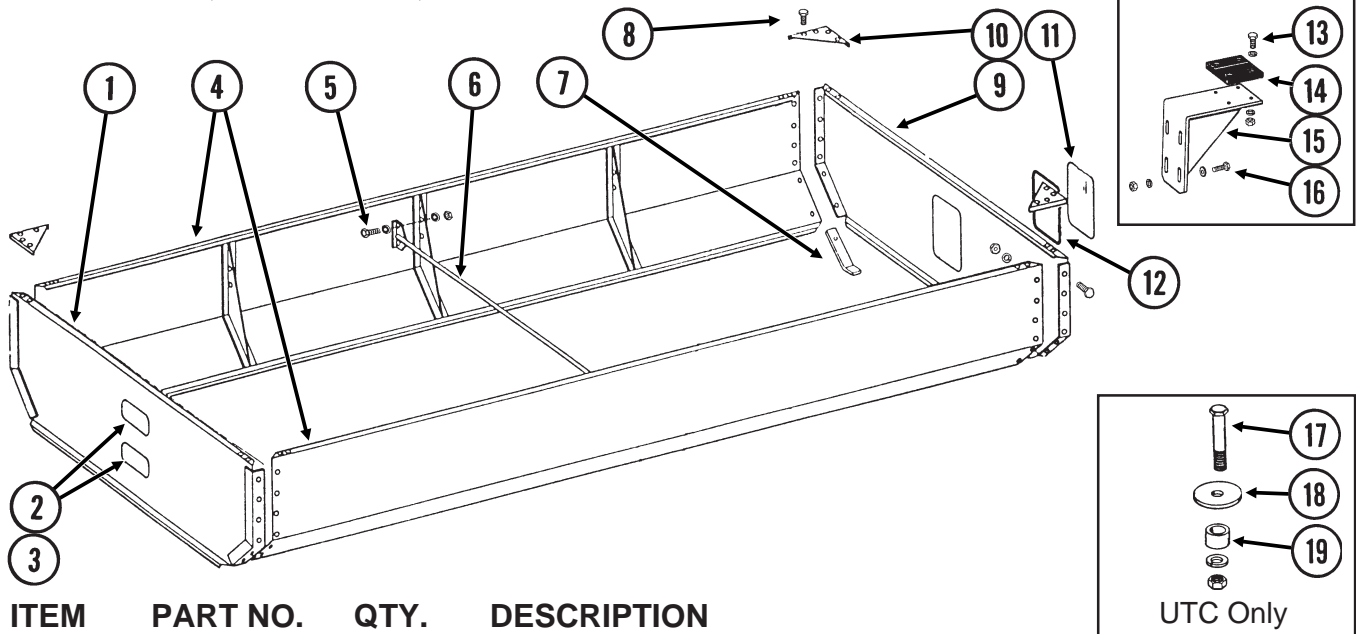

ITEM	PART NO.	QTY.	DESCRIPTION
1.	GA4194	1	Rear Panel, 37 3/8" x 120 1/2", 840
	GA5779	-	Rear Panel, 49 7/8" x 132 1/2", 1040
2.	GD6460	2	Rear Window, 6 1/2" x 10 1/2"
3.	GD6461-01	2	Rear Window Molding
4.	GA4196	2	Side Panel, 37 3/8" x 239 1/2", 840
	GA5776	-	Side Panel, 49 7/8" x 239 1/2", 1040
5.	G10017	-	Hex Head Cap Screw, 1/2"-13 x 1 1/2"
	G10228	-	Lock Washer, 1/2"
	G10102	-	Hex Nut, 1/2"-13
6.	GA0437	3	Cross Brace, 119 1/2", 840
	GA5778	4	Cross Brace, 131 1/2", 1040
7.	GD4173	-	Corner Patch, 2 1/2" x 7 1/2", Wheel And Sof-Trak/UTC Wagons
	GD8225	-	Corner Patch, 2 1/2" x 10", Row Crop Wagons
8.	G10001	16	Hex Head Cap Screw, 3/8"-16 x 1"
	G10229	16	Lock Washer, 3/8"
	G10101	16	Hex Nut, 3/8"-16
9.	GA5772	1	Front Panel, 37 3/8" x 120 1/2", 840
	GA5780	-	Front Panel, 49 7/8" x 132 1/2", 1040
10.	GD0327	4	Corner Cap
11.	GD6487	1	Front Window, 10 1/2" x 19 1/4"
12.	GD6461-02	1	Front Window Molding
13.	G10003	4	Hex Head Cap Screw, 3/8"-16 x 1 1/2"
	G10210	4	Washer, 3/8" USS
	G10229	4	Lock Washer, 3/8"
	G10101	4	Hex Nut, 3/8"-16
14.	GD6978	1	Rubber Stop
15.	GA4664	1	Adjustable Stop Bracket
16.	G10017	4	Hex Head Cap Screw, 1/2"-13 x 1 1/2"
	G10228	4	Lock Washer, 1/2"
	G10216	4	Washer, 1/2" USS
	G10102	4	Hex Nut, 1/2"-13
17.	G10028	4	Hex Head Cap Screw, 3/4"-10 x 3" (Secures Grain Wagon To UTC)
	G10056	-	Hex Head Cap Screw, 3/4"-10 x 3 1/2" (Electronic Scale Equipped Machines-Replaces 3" Hex Head Cap Screw)
	G10231	4	Lock Washer, 3/4"
	G10105	4	Hex Nut, 3/4"-10
18.	GD9602-02	4	Sleeve, 3/8" (Between Grain Wagon And UTC)
	GD9602-01	-	Sleeve, 1 1/4" (Electronic Scale Equipped Machines-Replaces 3/8" Sleeve)
19.	GD9592	4	Special Washer

# AXLE

# 640/840 WHEEL WAGON

HTA038(WGN38a)

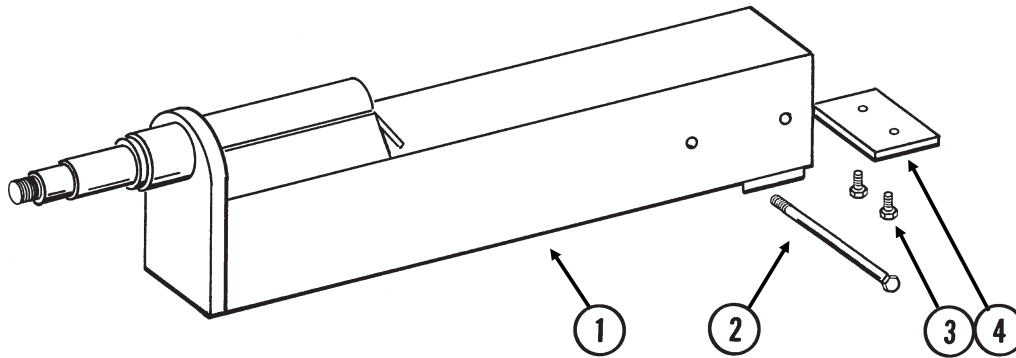

ITEM	PART NO.	QTY.	DESCRIPTION
(Per Wagon)			
1.	GA5734	2	Stub Axle
2.	G10540	2	Hex Head Cap Screw, 1"-8 x 12"
	G10117	2	Hex Nut, 1"-8
3.	G10014	4	Hex Head Cap Screw, 1/2"-13 x 1"
	G10228	4	Lock Washer, 1/2"
4.	GD7538	2	Shim, 5" x 8"

# WEIGH AXLE

# 640/840 WHEEL WAGON

HTA030(WGN39a)

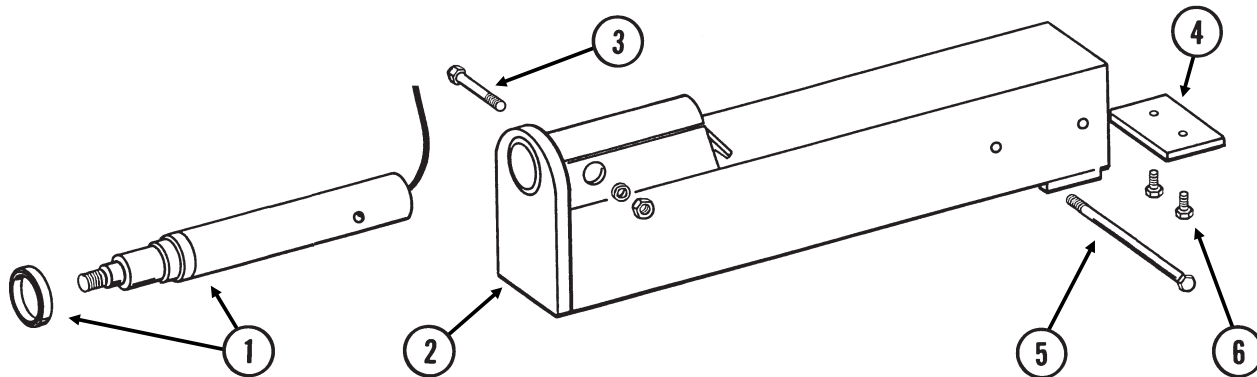

ITEM	PART NO.	QTY.	DESCRIPTION
(Per Wagon)			
1.	GA4687	2	Weigh Axle W/Spacer, 4 1/2"
	GD6996	-	Spacer
2.	GA5736	1	Stub Axle, R.H.
	GA5737	1	Stub Axle, L.H.
3.	G10011	2	Hex Head Cap Screw, 5/8"-11 x 5 1/2"
	G10107	2	Lock Nut, 5/8"-11
4.	GD7538	2	Shim, 5" x 8"
5.	G10540	2	Hex Head Cap Screw, 1"-8 x 12"
	G10117	2	Hex Nut, 1"-8
6.	G10014	4	Hex Head Cap Screw, 1/2"-13 x 1"
	G10228	4	Lock Washer, 1/2"

# AXLE

# 840/1040 ROW CROP WAGON

HTA037(WGN40a/WGN72)

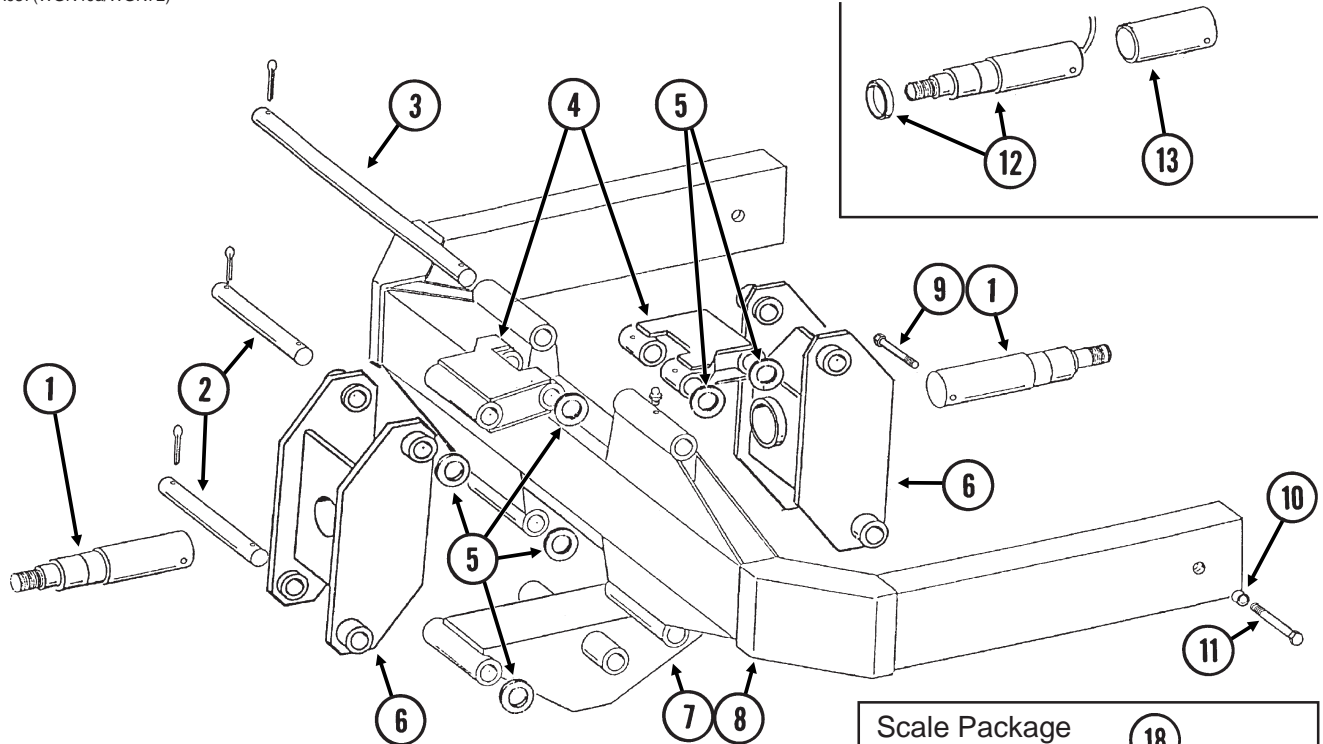

ITEM	PART NO.	QTY. (Per Wagon)	DESCRIPTION
1.	GD8037	4	Spindle, 4 1/2"
2.	GD8119	8	Pin, 2 1/8" x 16 1/4"
	G10461	16	Cotter Pin, 3/8" x 3"
3.	GD8140	2	Pin, 2 1/8" x 36 1/2"
	G10461	4	Cotter Pin, 3/8" x 3"
4.	GA5797	4	Top Link Arm W/Adapter And Grease Fittings
	G10914	-	Adapter, 1/8" Male NPT To Female
	G10343	-	Grease Fitting, 90°, 1/8"-27
	G10641	-	Grease Fitting, 1/8" NPT
5.	G10234	-	Machine Bushing, 2 1/8", 10 Gauge (As Required)
	G10336	-	Machine Bushing, 2 1/8", 14 Gauge (As Required)
6.	GA5790	4	Link Plate W/Grease Fittings
	G10641	-	Grease Fitting, 1/8" NPT
7.	GA5789	2	Bottom Link Arm W/Grease Fittings
	G10640	-	Grease Fitting, 1/4"-28
8.	GA5806	2	Extension Axle W/Grease Fittings
	G10641	-	Grease Fitting, 1/8" NPT
9.	G10400	4	Hex Head Cap Screw, 3/4"-10 x 6 1/2"
	G10112	4	Lock Nut, 3/4"-10
10.	GD7585-06	-	Sleeve, 1 3/4"
11.	G10402	4	Hex Head Cap Screw, 1"-8 x 8"
	G10396	4	Lock Nut, 1"-8
12.	GA6752	-	Weigh Axle W/Spacer, 4 1/2"
	GD6996	-	Spacer
13.	GD9594	-	Sleeve, 7 1/8"
14.	GD10739	8	Conduit Clamp, 1" EMT (For Scale Wires)
15.	GD10740	2	Conduit Tube (For Scale Wires)
16.	G10023	4	Hex Head Cap Screw, 1/4"-20 x 3/4" (For Scale Wires)
	G10110	4	Lock Nut, 1/4"-20 (For Scale Wires)
17.	GA7818	1	EMT Connector, 1" (For Scale Wires)
18.	GD10759	1	Insulating Bushing, 1" (For Scale Wires)



# AXLE

# 640/840 SOF-TRAK/UTC

HTA033/HTA036(WGN41a)

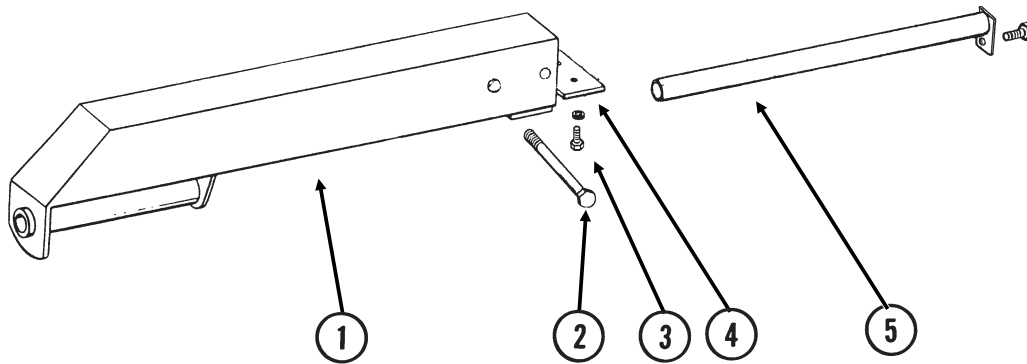

ITEM	PART NO.	QTY.	DESCRIPTION
		(Per Wagon)	
1.	GA5489	2	Stub Axle W/Grease Fittings
	G10641	-	Grease Fitting, 1/8" NPT
2.	G10540	2	Hex Head Cap Screw, 1"-8 x 12"
	G10117	2	Hex Nut, 1"-8
3.	G10014	4	Hex Head Cap Screw, 1/2"-13 x 1"
	G10228	4	Lock Washer, 1/2"
4.	GD7538	2	Shim, 5" x 8"
5.		-	See "Track And Carriage", Page P38

# ADJUSTABLE AXLE, BOLT-ON

# 640/840 WHEEL AND SOF-TRAK

(WGN137b)

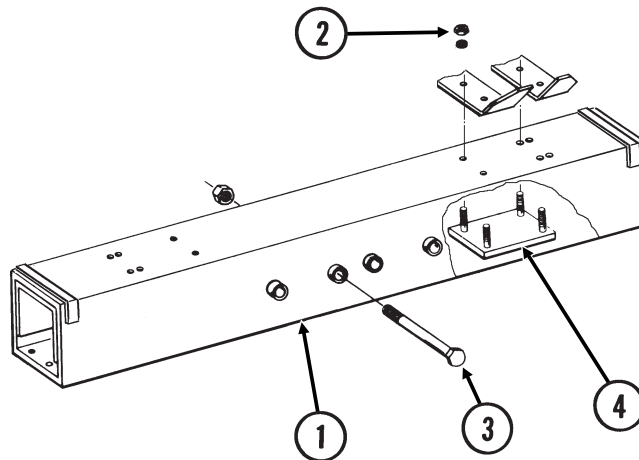

ITEM	PART NO.	QTY.	DESCRIPTION
1.	GA8185	1	Bolt-On Adjustable Axle Receiver
2.	G10231	8	Lock Washer, 3/4"
	G10105	8	Hex Nut, 3/4"-10
3.		-	See "Axle", Pages P34 And P36
4.	GA5535	2	Mount, 7" x 11", 840
	GA5534	-	Mount, 7" x 10", 640

# HUB AND TIRE ASSEMBLY

# WHEEL/ROW CROP

HTA002/HTA004/HTA039(WGN42b/WGN80/WGN81)

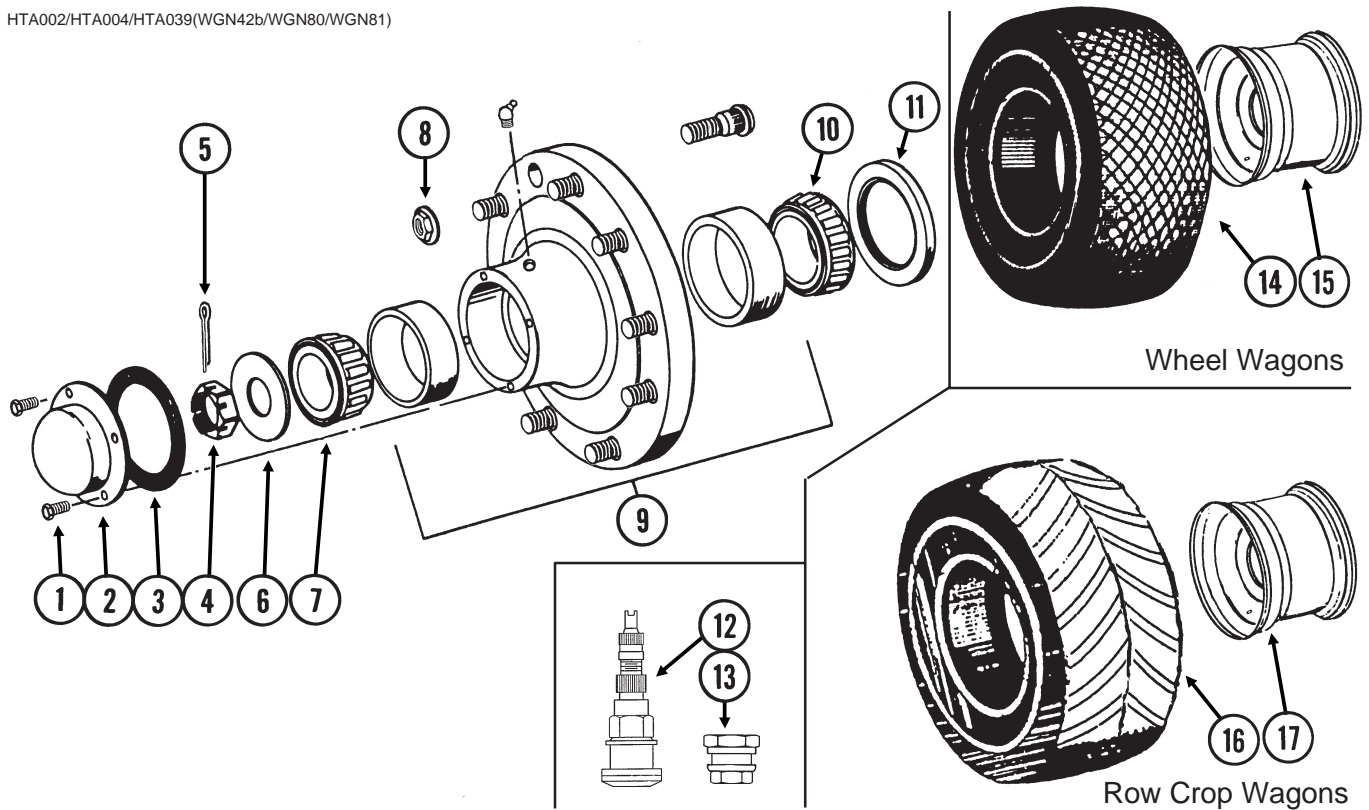

ITEM	PART NO.	QTY.	DESCRIPTION
(Per Wagon)			
1.	G10054	4	Hex Head Cap Screw, 5/16"-18 x 1/2"
2.	GD1360	1	Dust Cap
3.	GD1359	1	Seal
4.	G10726	1	Slotted Hex Nut, 2"-12
5.	G10471	1	Cotter Pin, 3/8" x 2 1/2"
6.	G10198	1	Washer, 2"
7.	GA0530	1	Outer Bearing
8.	G10625	10	Flange Nut, 3/4"-16
9.	GA0529	1	Hub W/Cups, Grease Fitting And Stud Bolts (10 Bolt)
	GR0192	-	Outer Cup
	GR0191	-	Inner Cup
	G10373	-	Grease Fitting, 45°, 1/8"-27
	GR0257	-	Bolt, 3/4"-16 x 2 1/2"
10.	GA0531	1	Inner Bearing
11.	GA0532	1	Seal
12.	GA6128	-	Valve Stem
13.	GA5447	-	Brass Plug
14.	D4093	-	Tire, 24.5" x 32" R-3 Diamond-Type Tread, 12 Ply, 640 (Used W/GA0446 Wheel) <b>(Non-Stock Item)</b>
	D8495	-	Tire, 24.5" x 32" R-1 Traction-Type Tread, 12 Ply, 640 (Used W/GA0446 Wheel) <b>(Non-Stock Item)</b>
	D11013	-	Tire, 30.5" x 32" R-3 Diamond-Type Tread, 16 Ply, 640/840 (Used W/GA0445 Wheel) <b>(Non-Stock Item)</b>
	D11012	-	Tire, 30.5" x 32" R-1 Traction-Type Tread, 16 Ply, 640/840 (Used W/GA0445 Wheel) <b>(Non-Stock Item)</b>
15.	GA0446	-	Wheel, 21" x 32", 640 (Used W/D4093 Or D8495 Tire)
	GA0445	-	Wheel, 27" x 32", 640/840 (Used W/D11013 Or D11012 Tire)
16.	D10909	-	Tire, 18.4" x 38" R-1 Traction-Type Tread, 14 Ply <b>(Non-Stock Item)</b>
	D11899	-	Tire, 18.4" x 38" R-1 Traction-Type Tread, Radial <b>(Non-Stock Item)</b>
17.	GA5768	-	Wheel, WH16A x 38"

# TRACK AND CARRIAGE

# 640/840 SOF-TRAK/UTC

HTA033(WGN43a/WGN43b)

STYLE B

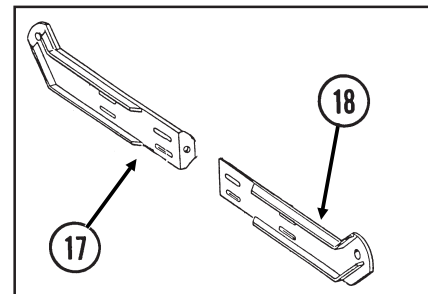
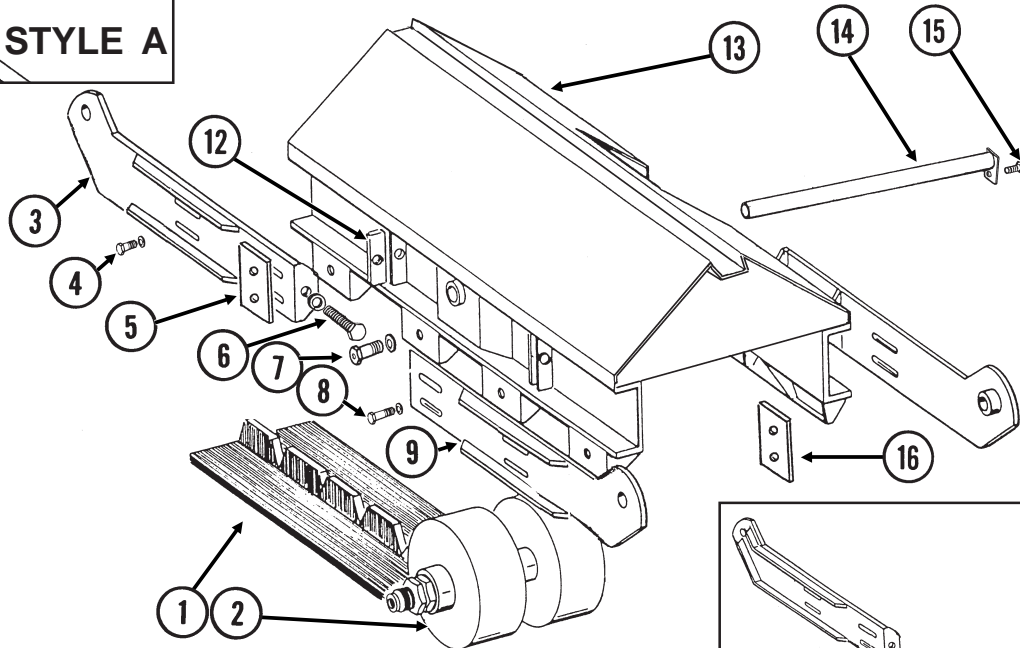
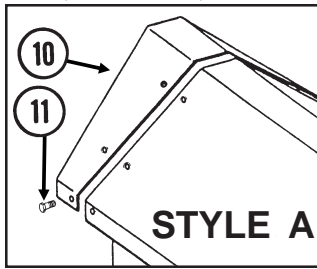

ITEM	PART NO.	QTY. (Per Assy.)	DESCRIPTION
1.	GD7096	1	Rubber Track, 24" (Specify Brand*)
	GD9900	-	Rubber Track, 36" (Specify Brand*)
2.		-	See "Mid Wheel, Sof-Trak/UTC", Page P39
3.	GA9653	2	Sidebar, L.H.
4.	G10537	8	Hex Head Cap Screw, 3/4"-16 x 2 1/2"
5.	GD8279	8	Plate, 2" x 4 1/2"
6.	G10539	4	Hex Head Adjusting Bolt, 1"-14 x 7"
	G10082	4	Washer, 1" SAE
7.		4	See "Mid Wheel, Sof-Trak/UTC", Page P39
8.	G10538	8	Hex Head Cap Screw, 3/4"-16 x 4 1/2"
9.	GA9652	2	Sidebar, R.H.
10.	GD7521	2	Mud Scraper
11.	G10014	12	Hex Head Cap Screw, 1/2"-13 x 1"
	G10216	12	Washer, 1/2" USS
	G10228	12	Lock Washer, 1/2"
	G10102	12	Hex Nut, 1/2"-13
12.	GD8860	4	Tap Block
13.	A9606	-	Track And Carriage <b>(Non-Stock Item)</b>
14.	GA5514	1	Pin
15.	G10005	1	Hex Head Cap Screw, 5/8"-11 x 1 3/4"
16.	GD10136	8	Threaded Plate
17.	A5477	-	Sidebar, L.H. <b>(Non-Stock Item) (Sub GA9653)</b>
18.	A5476	-	Sidebar, R.H. <b>(Non-Stock Item) (Sub GA9652)</b>

\* Specific brand requests will be supplied only as available from current KINZE® stock. If a specific brand requested is not in stock, the brand available will be supplied.

# MID WHEEL

# SOF-TRAK/UTC

HTA035(WGN44b)

## STYLE A

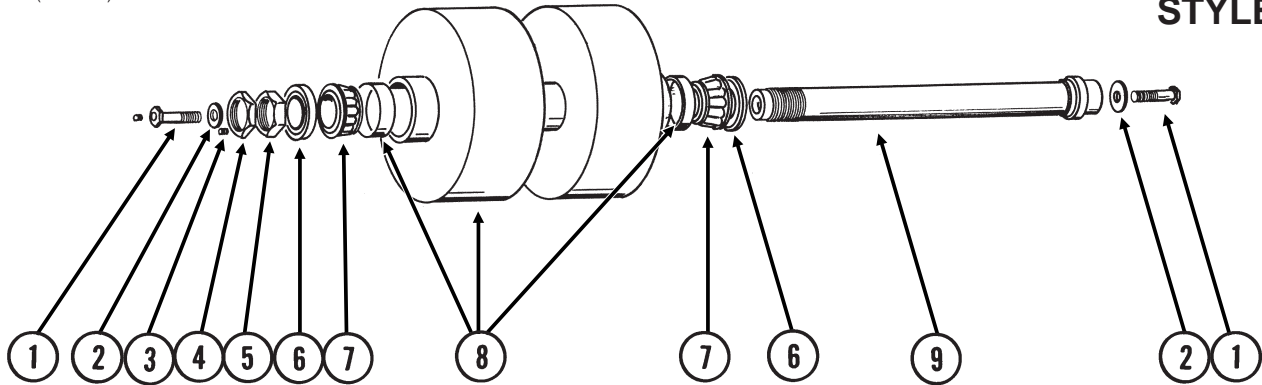

## STYLE B

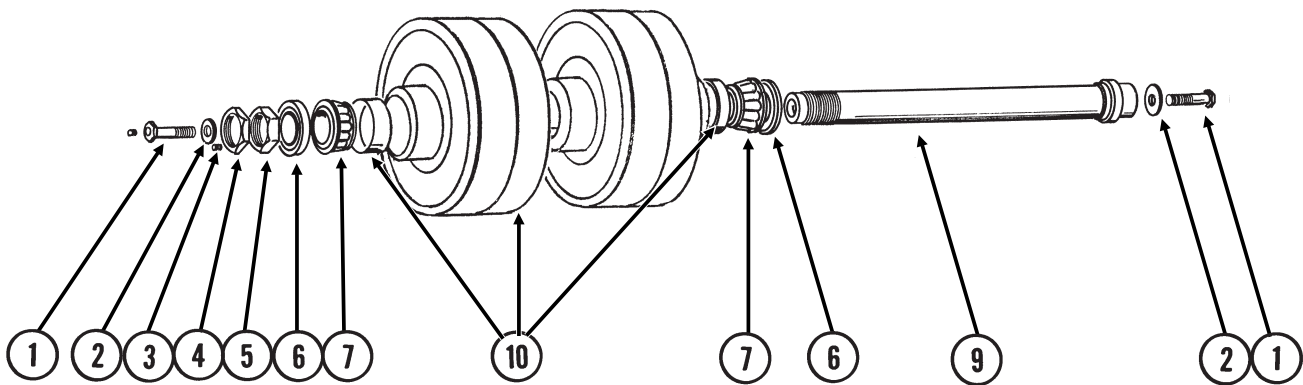

ITEM	PART NO.	QTY. (Per Assy.)	DESCRIPTION
1.	GA5487	2	Bolt W/Grease Fitting, 1 1/4" x 3 1/2", Grade 8
	G10641	-	Grease Fitting, 1/8" NPT
2.	G10236	2	Lock Washer, 1 1/4"
3.	G10535	1	Hex Socket Set Screw, 3/8"-16 x 3/4"
4.	GD7460	1	Jam Nut, 2 1/2"-12
5.	GD7451	1	Stepped Nut, 2 1/2"-12
6.	GD7452	2	Seal
7.	GA0779	2	Bearing
8.	GA5486	1	Mid Wheel W/Cups (Welded/Machined), Style A
	GR0323	-	Cup
9.	GA4999	1	Spindle
10.	GA6889	-	Mid Wheel W/Cups (Formed/Machined), Style B
	GR0323	-	Cup
A.	GA6890	-	Mid Wheel Assembly (Items 1-7, 9 And 10)

# END WHEEL, RUBBER-TIRE

# SOF-TRAK/UTC

HTA034(WGN83a)

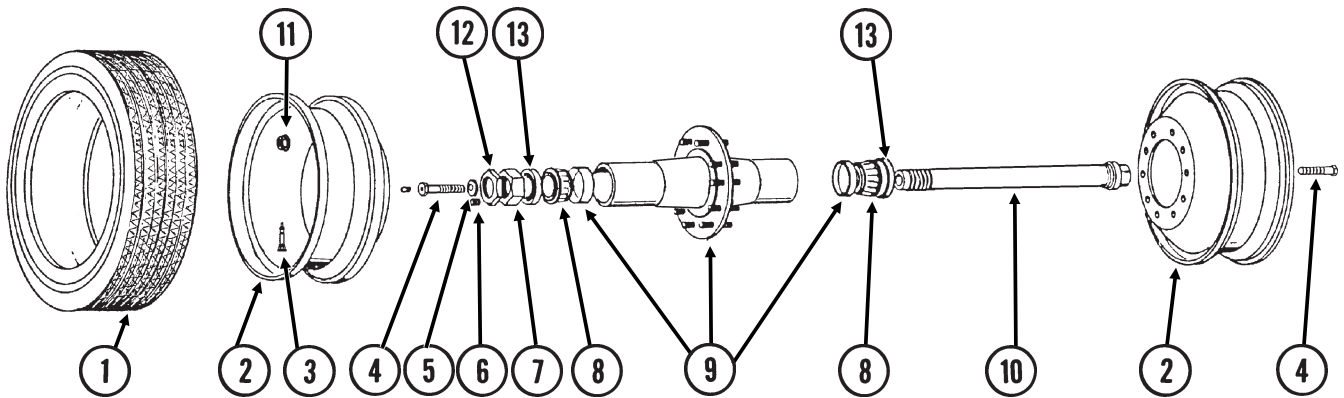
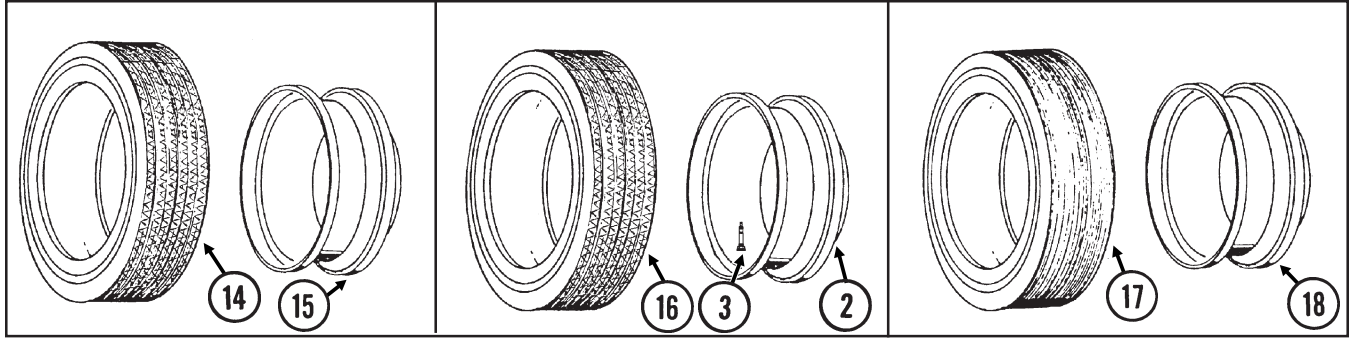

ITEM	PART NO.	QTY.	DESCRIPTION
(Per Assy.)			
1.	GD11092	2	Tubeless Tire, 9" x 22.5", 12 Ply, Treaded (Specify Brand *)
2.	GD10045	2	Rim
3.	GA7434	2	Valve Stem
4.	GA5487	2	Bolt W/Grease Fitting, 1 1/4" x 3 1/2", Grade 8
	G10641	1	Grease Fitting, 1/8" NPT
5.	G10236	2	Lock Washer, 1 1/4"
6.	G10535	1	Hex Socket Set Screw, 3/8"-16 x 3/4"
7.	GD7451	1	Stepped Nut, 2 1/2"-12
8.	GA0779	2	Bearing
9.	GA5484	1	Hub W/Cups And Bolts
	GR0323	-	Cup
	GD7489	-	Bolt (10 Bolt Hub), Threaded Both Ends
	GR0257	-	Bolt, 3/4"-16 x 2 1/2"
10.	GA4999	1	Spindle
11.	GR0256	20	Lug Nut, 3/4"-16
12.	GD7460	1	Jam Nut, 2 1/2"-12
13.	GD7452	2	Seal
14.	D9307	2	Tube Type Tire, 8.25" x 20", 10 Ply, Treaded Truck <b>(Non-Stock Item)</b>
	D9308	-	Tube <b>(Non-Stock Item)</b>
	GD9777	-	Flap
15.	GA6879	2	Rim W/Lock Ring
	GD9778	-	Lock Ring
16.	D10044	2	Tubeless Tire, 9" x 22.5", 10 Ply, Treaded Truck <b>(Non-Stock Item)</b>
17.	D7640	2	Tube Type Tire, 8.25" x 20", Smooth <b>(Non-Stock Item)</b>
	A5574	-	Tube W/Insert <b>(Non-Stock Item)</b>
18.	GA5490	2	Rim W/Lock Ring
	GD7594	-	Lock Ring
A.	GA5483	-	Hub Assembly (Item 4-13)

\* Specific brand requests will be supplied only as available from current KINZE® stock. If a specific brand requested is not in stock, the brand available will be supplied.

HTA049(WGN138)

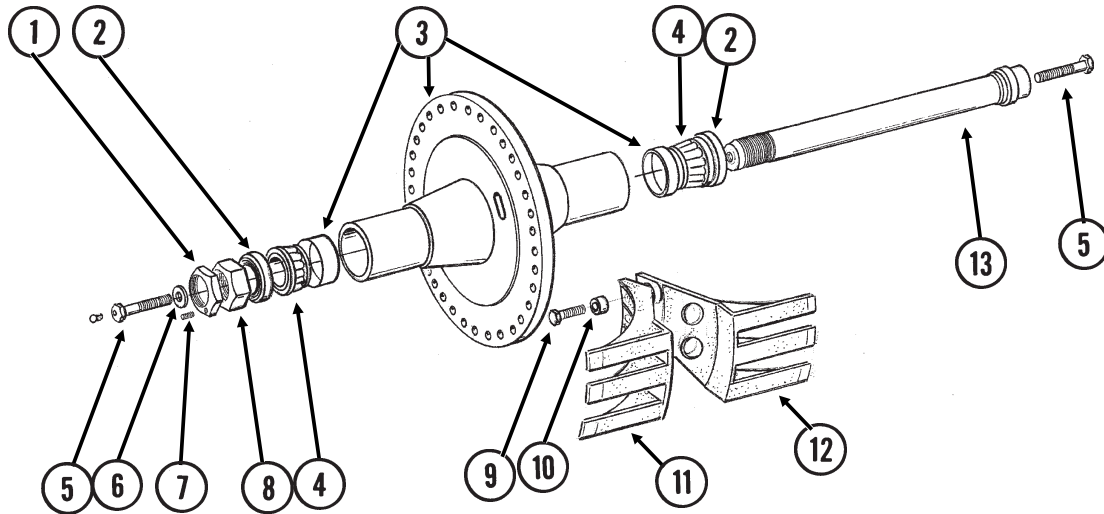

ITEM	PART NO.	QTY.	DESCRIPTION
		(Per Assy.)	
1.	GD7460	1	Jam Nut, 2 1/2"-12
2.	GD7452	2	Seal
3.	GA9607	1	Hub W/Cups
	GR0323	-	Cup
4.	GA0779	2	Bearing
5.	GA5487	2	Bolt W/Grease Fitting, 1 1/4" x 3 1/2", Grade 8
	G10641	1	Grease Fitting, 1/8" NPT
6.	G10236	2	Lock Washer, 1 1/4"
7.	G10535	1	Hex Socket Set Screw, 3/8"-16 x 3/4"
8.	GD7451	1	Stepped Nut, 2 1/2"-12
9.	G10056	12	Hex Head Cap Screw, 3/4"-10 x 3 1/2"
10.	GD13573	24	Spacer
11.	GD13552	12	Cast Iron Segment, Drilled
12.	GD13553	12	Cast Iron Segment, Tapped
13.	GA4999	1	Spindle



# HITCH CAP/PLATE

WAC004/WAC012/WAC013/WAC015(WGN46d)

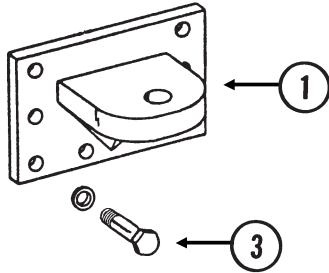

Wheel Wagon, Row Crop Wagon And UTC

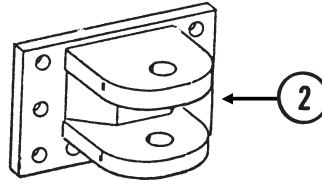

Wheel Wagon, Row Crop Wagon And UTC

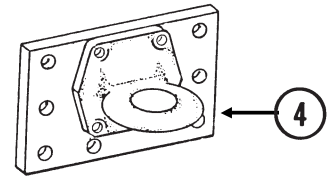

UTC Only (With Or Without Electronic Scale)

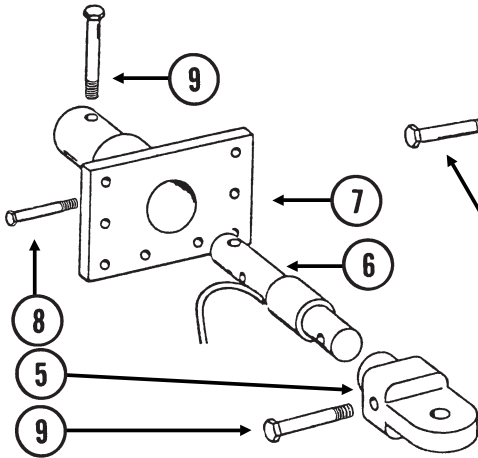

640 Wheel Wagon With Electronic Scale

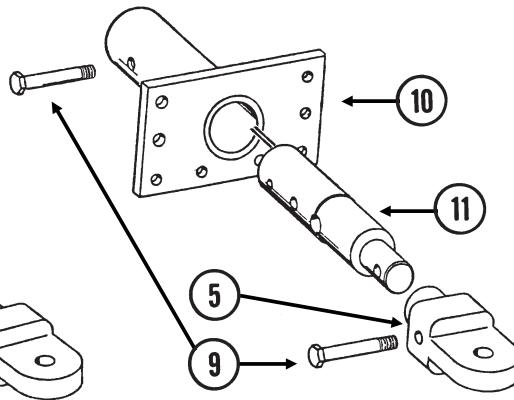

840/1040 Wheel/Row Crop Wagon With Electronic Scale

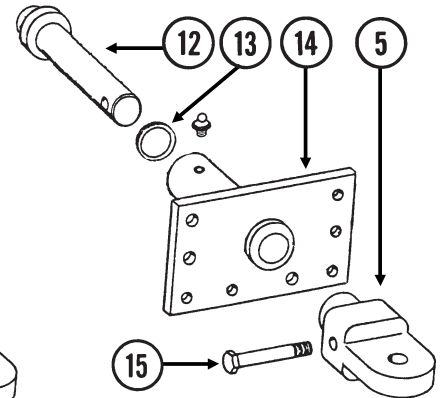

Wheel Wagon, Row Crop Wagon And UTC

ITEM	PART NO.	QTY.	DESCRIPTION
1.	GA7561	-	Hitch Cap, Single Clevis
2.	GA4214	-	Hitch Cap, Double Clevis
3.	G10441	8	Hex Head Cap Screw, 7/8"-9 x 3", Grade 8
	G10330	8	Lock Washer, 7/8"
	G10442	8	Hex Nut, 7/8"-9
4.	GA6093	-	Pintle Hitch
5.	GB0236	-	Single Clevis
	G1K271	-	Washer Kit, Includes: (1) Washer And (1) Instruction Sheet
6.	GA4681	-	Weigh Beam, 2 1/2"
7.	GA4680	-	Hitch Plate
8.	G10050	-	Hex Head Cap Screw, 3/4"-10 x 5"
	G10112	-	Lock Nut, 3/4"-10
9.	G10648	-	Hex Head Cap Screw, 1"-8 x 6", Grade 8
	G10647	-	Hex Nut, 1"-8, Grade 8
10.	GA6022	-	Hitch Plate
11.	GA6025	-	Weigh Beam, 3 3/4"
12.	GA7955	-	Pin
13.	G10360	1	Machine Bushing, 2 1/2", 10 Gauge
14.	GA7956	-	Hitch Plate W/Grease Fitting
	G10641	-	Grease Fitting, 1/8" NPT
15.	G10151	1	Hex Head Cap Screw, 1"-8 x 6"
	G10396	1	Lock Nut, 1"-8

# OPTIONAL SAFETY CHAIN

WAC011(WGN47)

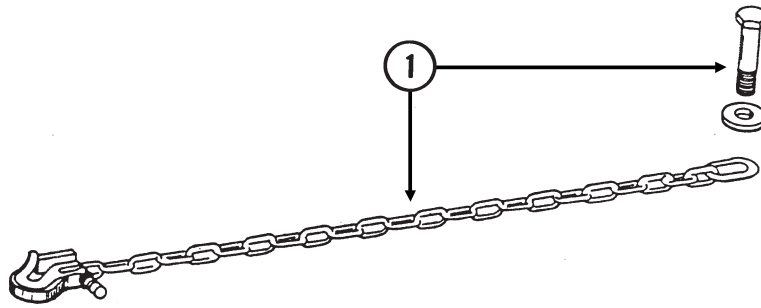

ITEM	PART NO.	QTY.	DESCRIPTION
1.	G1K175	1	Safety Chain Kit W/Hardware, 1/2"
	G10238	1	Hex Head Cap Screw, 1 1/4"-7 x 4"
	G10139	1	Washer, 1 1/4" USS
	G10236	1	Lock Washer, 1 1/4"
	G10239	1	Hex Nut, 1 1/4"-7

# VERTICAL AUGER FOLD CYLINDER

640/840/1040

(CYL3f)

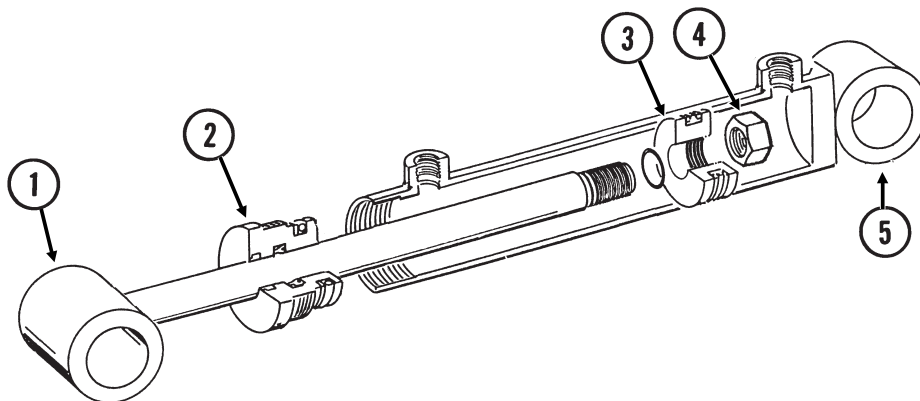

ITEM	PART NO.	QTY.	DESCRIPTION
1.	GA4193	1	Rod Assembly
2.	GD11926	1	Gland
3.	GD4525	1	Piston
4.	G10969	1	Lock Nut, 7/8"-14
5.	A4192	1	Barrel <b>(Non-Stock Item)</b>
A.	GA4115	-	Cylinder Complete, 2 1/2" x 20 1/16" <i>(Part Number Stamped On Barrel)</i> <b>(Sub GA8899)</b>
B.	GR0963	-	Seal Kit, Includes: (1) T-Seal, (2) O-Rings, (1) BU Ring, (1) U-Cup, (1) Wiper

# VERTICAL AUGER FOLD CYLINDER

640/840/1040

(CYL3f)

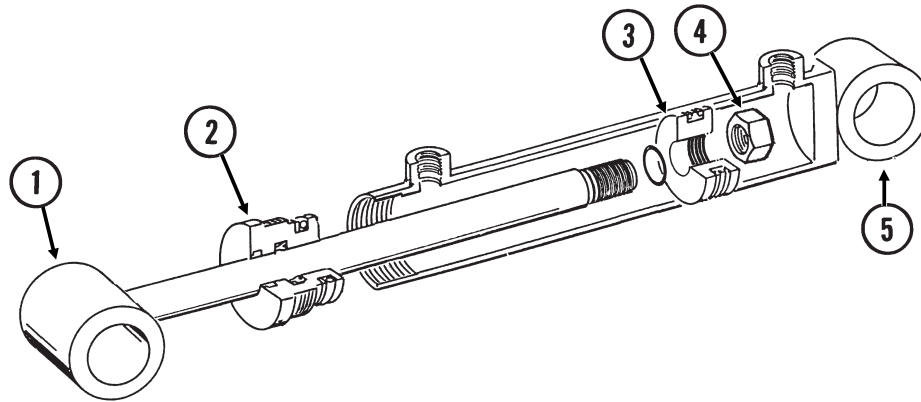

ITEM	PART NO.	QTY.	DESCRIPTION
1.	GA8821	1	Rod Assembly
2.	GD11926	1	Gland
3.	GD11986	1	Piston
4.	G10969	1	Lock Nut, 7/8"-14
5.	A8822	1	Barrel <b>(Non-Stock Item)</b>
A.	GA8823	-	Cylinder Complete, 2 1/2" x 20 1/16" <i>(Part Number Stamped On Barrel)</i> <b>(Sub GA8899)</b>
B.	GR0963	-	Seal Kit, Includes: (1) T-Seal, (2) O-Rings, (1) BU Ring, (1) U-Cup, (1) Wiper

# VERTICAL AUGER FOLD CYLINDER

640/840/1040

(CYL3f)

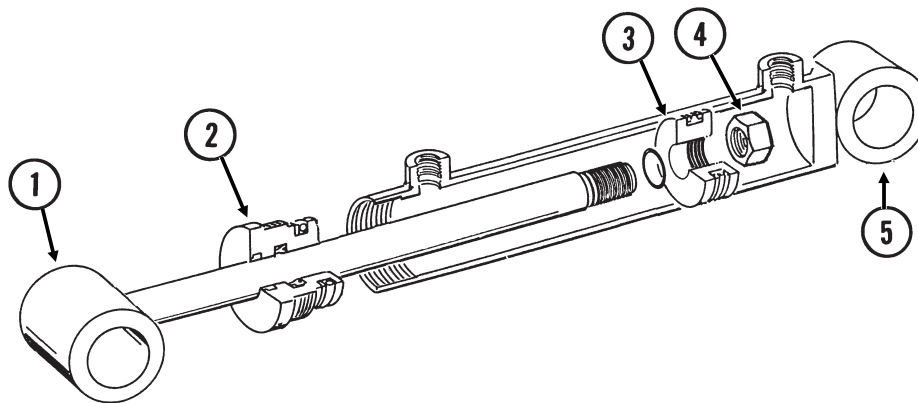

ITEM	PART NO.	QTY.	DESCRIPTION
1.	GA8898	1	Rod Assembly
2.	GD11985	1	Gland
3.	GD11986	1	Piston
4.	G10969	1	Lock Nut, 7/8"-14
5.	A8822	1	Barrel <b>(Non-Stock Item)</b>
A.	GA8899	-	Cylinder Complete, 2 1/2" x 20 1/16" <i>(Part Number Stamped On Barrel)</i>
B.	GR1522	-	Seal Kit, Includes: (1) T-Seal, (2) O-Rings, (1) BU Ring, (1) U-Cup, (1) Wiper

# GRAIN FLOW CONTROL GATE CYLINDER

640

CYL030/CYL049(CYL26b)

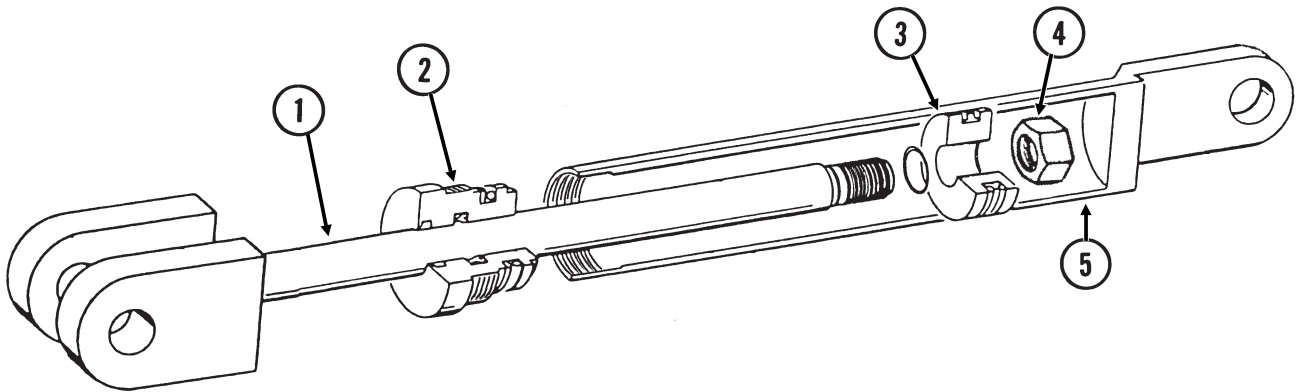

ITEM	PART NO.	QTY.	DESCRIPTION
1.	GA4188	1	Rod Assembly
2.	GD5949	1	Gland
3.	GD4632	1	Piston
4.	GR0959	1	Lock Nut, 3/4"-16
5.	A4187	1	Barrel <b>(Non-Stock Item)</b>
A.	GA4129	-	Cylinder Complete, 2" x 8" <i>(Part Number Stamped On Barrel)</i> <b>(Sub GA8920)</b>
B.	GR0927	-	Seal Kit, Includes: (1) T-Seal, (2) O-Rings, (1) BU Ring, (1) U-Cup, (1) Wiper

# GRAIN FLOW CONTROL GATE CYLINDER

640

CYL030/CYL049(CYL26b)

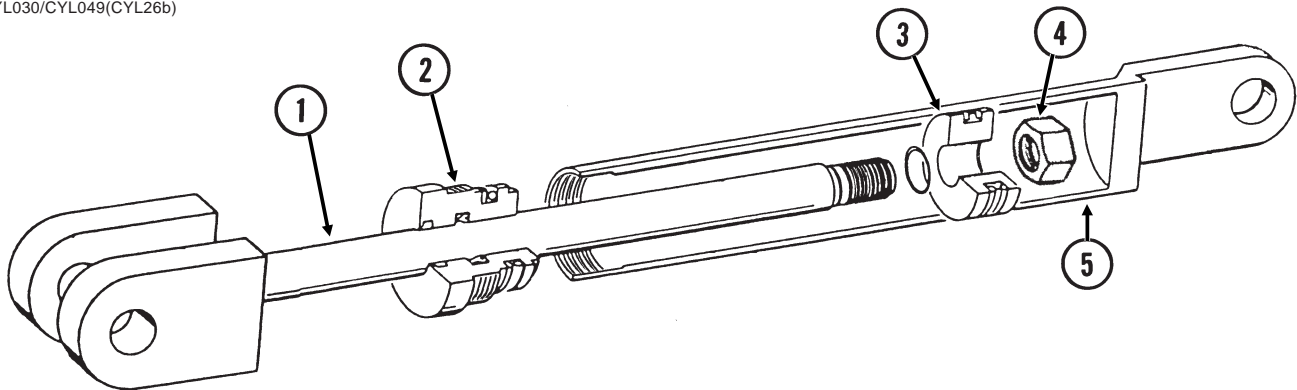

ITEM	PART NO.	QTY.	DESCRIPTION
1.	GA8816	1	Rod Assembly
2.	GD5949	1	Gland
3.	GD4632	1	Piston
4.	G10967	1	Lock Nut, 3/4"-16
5.	A8775	1	Barrel <b>(Non-Stock Item)</b>
A.	GA8818	-	Cylinder Complete, 2" x 8" <i>(Part Number Stamped On Barrel)</i> <b>(Sub GA8920)</b>
B.	GR0927	-	Seal Kit, Includes: (1) T-Seal, (2) O-Rings, (1) BU Ring, (1) U-Cup, (1) Wiper

# GRAIN FLOW CONTROL GATE CYLINDER

640

CYL030/CYL049(CYL26b)

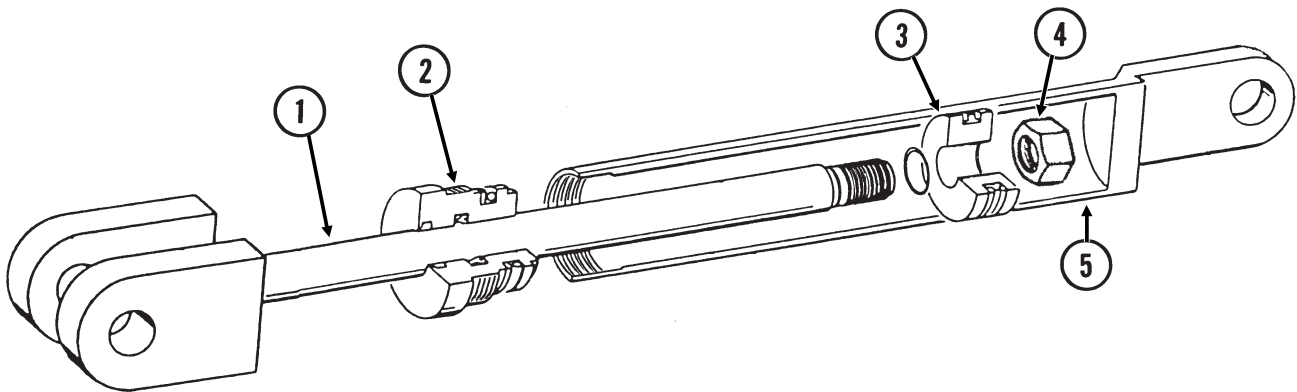

ITEM	PART NO.	QTY.	DESCRIPTION
1.	GA8921	1	Rod Assembly
2.	GD12510	1	Gland
3.	GD12511	1	Piston
4.	G10967	1	Lock Nut, 3/4"-16
5.	A8775	1	Barrel <b>(Non-Stock Item)</b>
A.	GA8920	-	Cylinder Complete, 2" x 8" <i>(Part Number Stamped On Barrel)</i>
B.	GR1529	-	Seal Kit, Includes: (1) T-Seal, (2) O-Rings, (1) BU Ring, (2) U-Cups, (1) Wiper, (1) IS511 Instruction

# GRAIN FLOW CONTROL GATE CYLINDER

840/1040

CYL044(CYL27d)

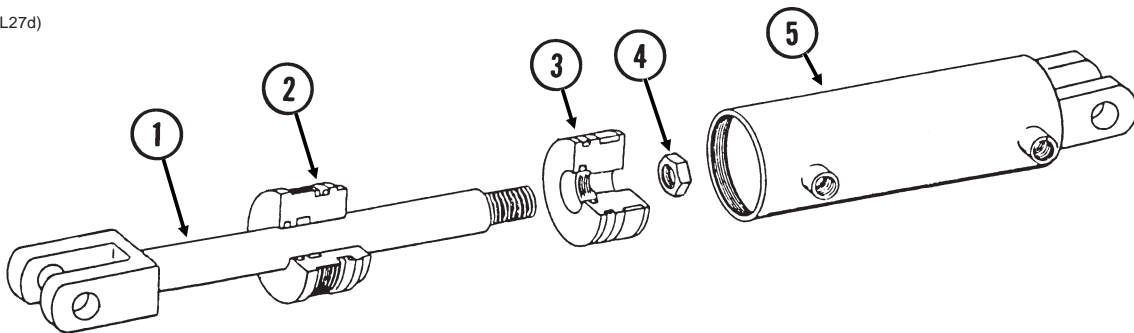

ITEM	PART NO.	QTY.	DESCRIPTION
1.	GA4757	1	Rod Assembly
2.	GD5954	1	Gland
3.	GD5956	1	Piston
4.	GR0986	1	Special Jam Nut, 1"-14
5.	A4756	1	Barrel <b>(Non-Stock Item)</b>
A.	GA4255	-	Cylinder Complete, 2 1/2" x 10" <i>(Part Number Stamped On Barrel)</i> <b>(Sub GA8900)</b>
B.	GR0930	-	Seal Kit, Includes: (1) Wear Ring, (1) T-Seal, (2) O-Rings, (1) BU Ring, (1) U-Cup, (1) Wiper

# GRAIN FLOW CONTROL GATE CYLINDER

840/1040

CYL044(CYL27c)

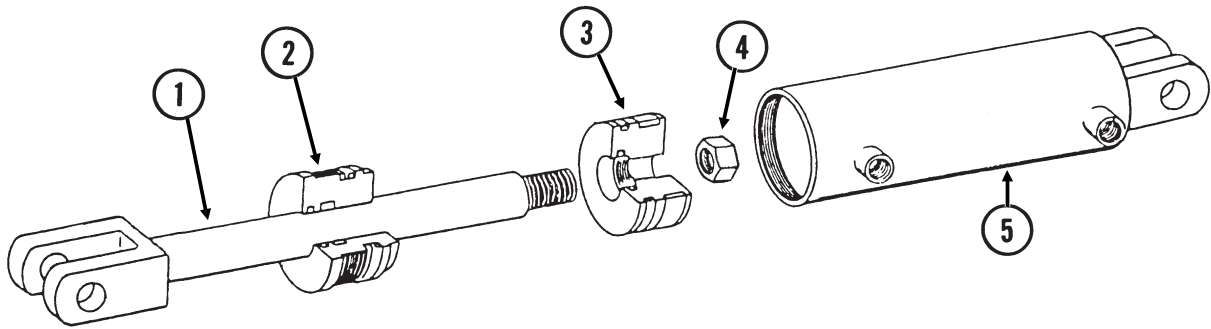

ITEM	PART NO.	QTY.	DESCRIPTION
1.	GA4757	1	Rod Assembly
2.	GD11926	1	Gland
3.	GD11888	1	Piston
4.	G10958	1	Lock Nut, 1"-14
5.	A8824	1	Barrel <b>(Non-Stock Item)</b>
A.	GA8825	-	Cylinder Complete, 2 1/2" x 10" (Part Number Stamped On Barrel) <b>(Sub GA8900)</b>
B.	GR0930	-	Seal Kit, Includes: (1) Wear Ring, (1) T-Seal, (2) O-Rings, (1) BU Ring, (1) U-Cup, (1) Wiper

# GRAIN FLOW CONTROL GATE CYLINDER

840/1040

CYL044(CYL27e)

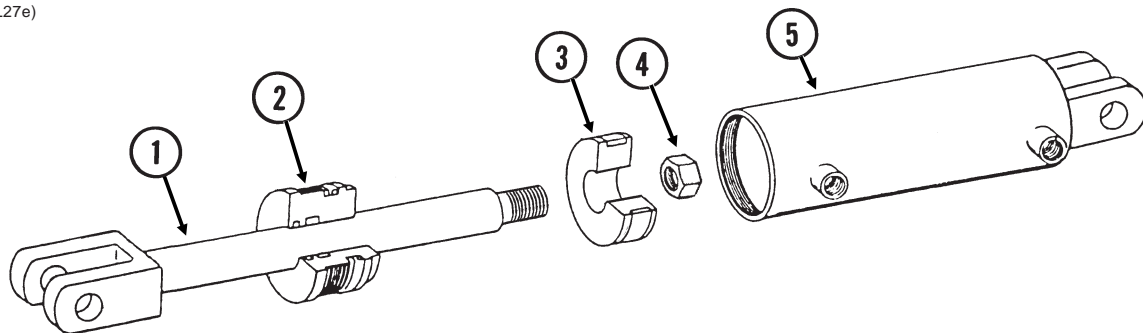

ITEM	PART NO.	QTY.	DESCRIPTION
1.	GA8901	1	Rod Assembly
2.	GD11985	1	Gland
3.	GD11986	1	Piston
4.	G10969	1	Lock Nut, 7/8"-14
5.	A8824	1	Barrel <b>(Non-Stock Item)</b>
A.	GA8900	-	Cylinder Complete, 2 1/2" x 10" (Part Number Stamped On Barrel)
B.	GR1522	-	Seal Kit, Includes: (1) T-Seal, (2) O-Rings, (1) BU Ring, (1) U-Cup, (1) Wiper



WAC002/WAC003(WGN136a)

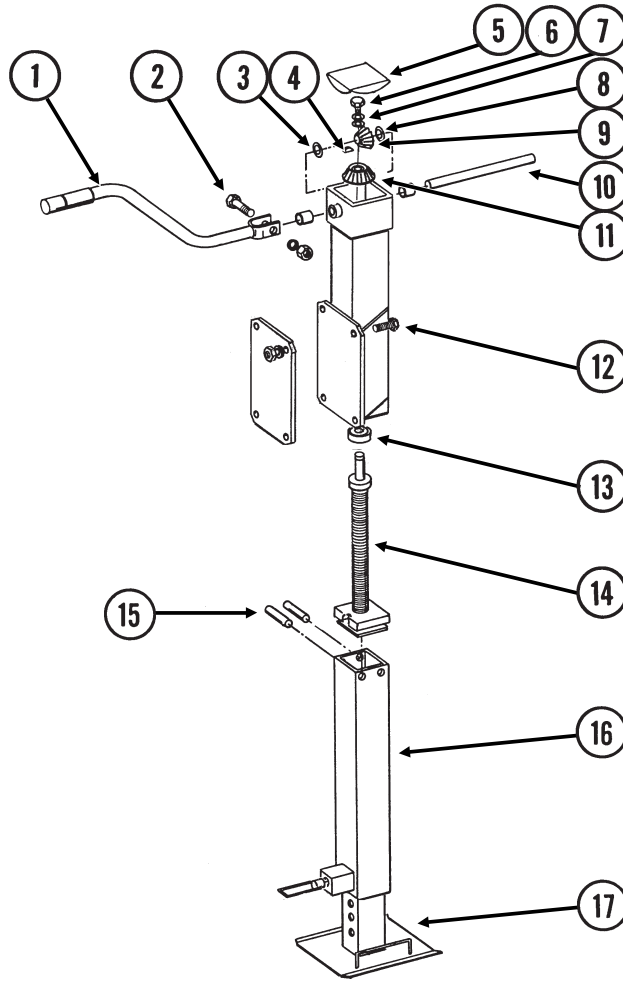

ITEM	PART NO.	QTY.	DESCRIPTION
1.	GD1350	1	Handle
2.	G10049	1	Hex Head Cap Screw, $\frac{3}{8}$ "-16 x 2 $\frac{1}{2}$ "
	G10210	2	Washer, $\frac{3}{8}$ " USS
	G10108	1	Lock Nut, $\frac{3}{8}$ "-16
3.	GR0692	3	Machine Washer, 1" x 2" x 18 Gauge
4.	GR0694	2	Key
5.	GR0700	1	Lid
6.	GR0703	1	Retaining Hex Head Cap Screw
7.	GR0702	2	Retaining Washer, $\frac{1}{2}$ "
8.	GR0704	1	Snap Ring
9.	GR0698	1	Gear, 12 Tooth
10.	GR0977	1	Shaft
11.	GR0693	1	Gear, 18 Tooth
12.	G10005	4	Hex Head Cap Screw, $\frac{5}{8}$ "-11 x 1 $\frac{3}{4}$ "
	G10230	4	Lock Washer, $\frac{5}{8}$ "
	G10104	4	Hex Nut, $\frac{5}{8}$ "-11
13.	GR0691	1	Bearing
14.	GR0974	1	Nut And Screw Assembly
15.	GR0976	2	Pin
16.	GR1009	1	Secondary W/Lock Assembly
17.	GR1008	1	Drop Tube
A.	G1K168	-	Jack Replacement Kit, 640

WAC003(WGN136)

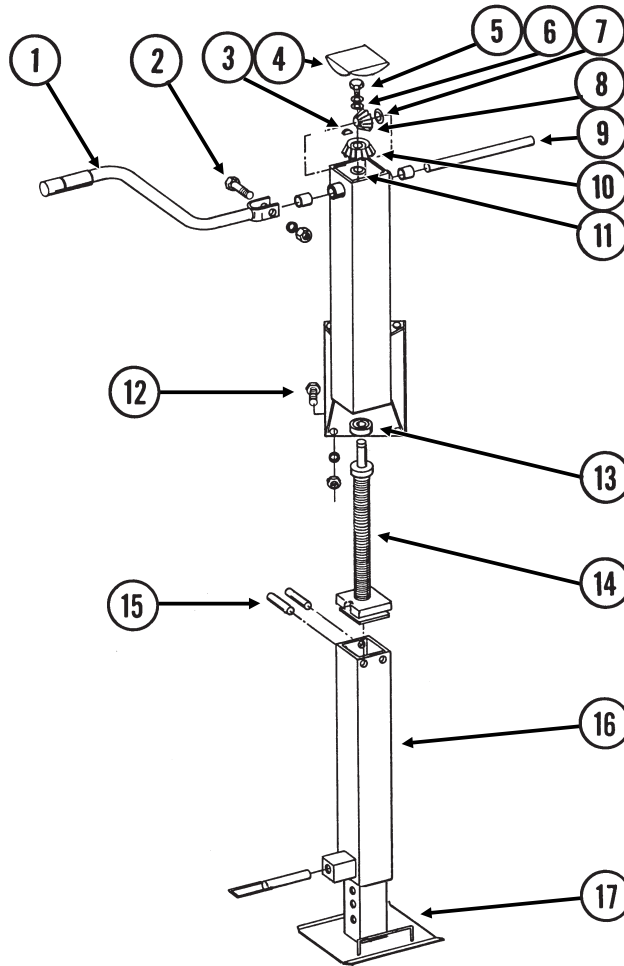

ITEM	PART NO.	QTY.	DESCRIPTION
1.	GD1350	1	Handle
2.	G10049	1	Hex Head Cap Screw, $\frac{3}{8}$ "-16 x 2 $\frac{1}{2}$ "
	G10210	2	Washer, $\frac{3}{8}$ " USS
	G10108	1	Lock Nut, $\frac{3}{8}$ "-16
3.	GR0694	2	Key
4.	GR0700	1	Lid
5.	GR0703	1	Retaining Hex Head Cap Screw
6.	GR0702	2	Retaining Washer, $\frac{1}{2}$ "
7.	GR0704	1	Snap Ring
8.	GR0698	1	Gear, 12 Tooth
9.	GR0696	1	Shaft
10.	GR0693	1	Gear, 18 Tooth
11.	GR0692	3	Machine Washer, 1" x 2" x 18 Gauge
12.	G10005	4	Hex Head Cap Screw, $\frac{5}{8}$ "-11 x 1 $\frac{3}{4}$ "
	G10230	4	Lock Washer, $\frac{5}{8}$ "
	G10104	4	Hex Nut, $\frac{5}{8}$ "-11
13.	GR0691	1	Bearing
14.	GR0689	1	Nut And Screw Assembly
15.	GR0690	2	Pin
16.	GR1011	1	Secondary W/Lock Assembly
17.	GR1010	1	Drop Tube
A.	GR0449	-	Jack Replacement Kit, 840/1040 (Shown)
	GA6030	-	Jack Replacement Kit, UTC

# ELECTRONIC SCALE COMPONENTS

WTP004/WTP008/WAC019/RH0395(WGN50b/WGN54a/WGN134/WGN8a/WGN58a/WGN60c/WGN61a/WGN61b/WGN61c)

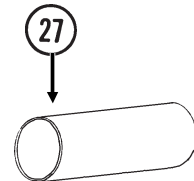
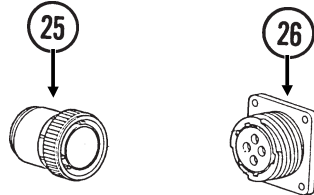
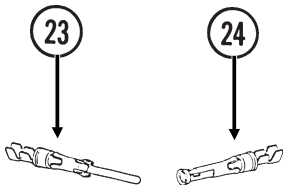
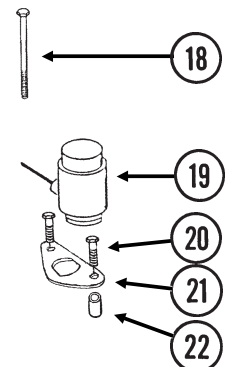
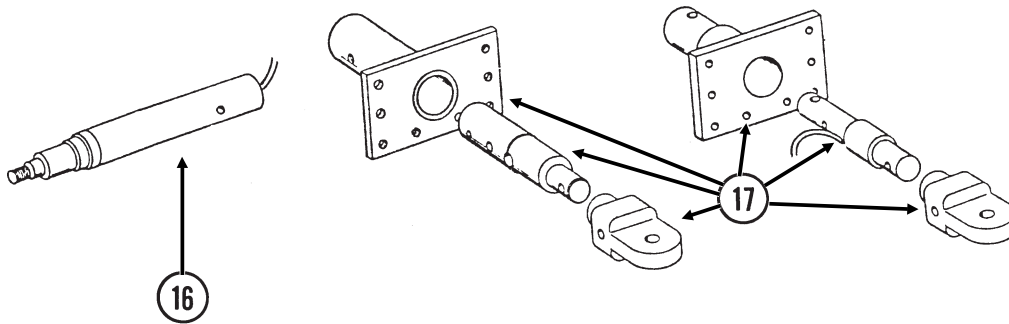
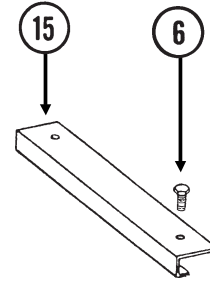
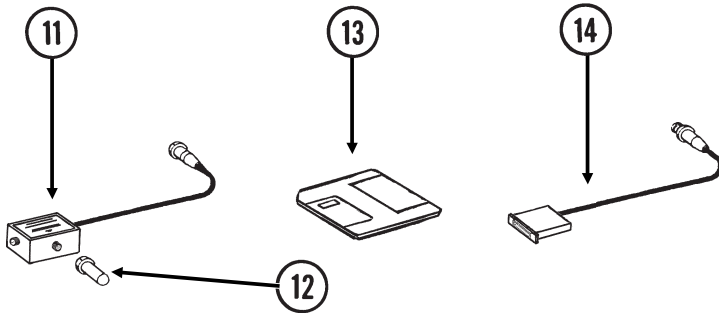
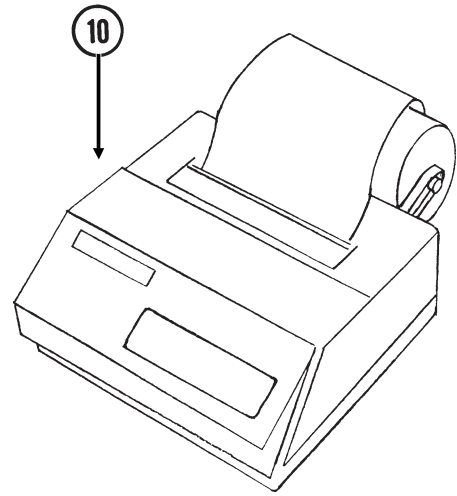
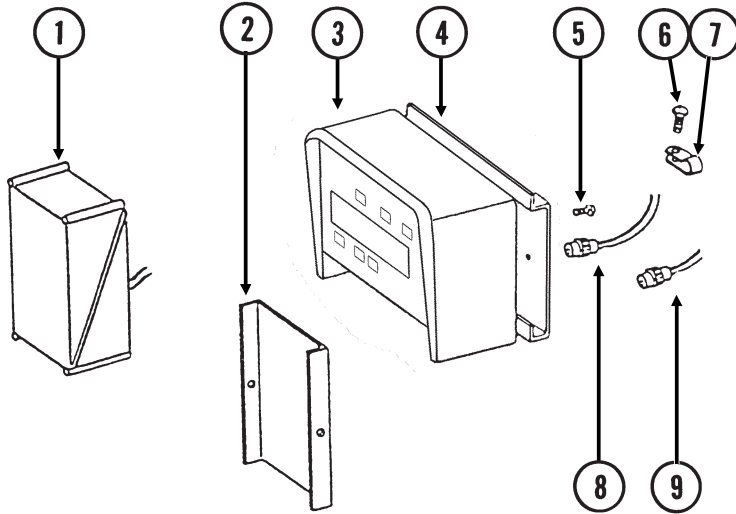

# ELECTRONIC SCALE COMPONENTS

ITEM	PART NO.	QTY.	DESCRIPTION
1.	GA5692	1	Junction Box W/30' Cable, 640/840 Wheel Wagons And UTC
	GA7312	-	Junction Box W/30' Cable, 840/1040 Row Crop Wagons
	GR1431	-	Cable 30' (If Applicable)
2.	GD7008	1	Cover, 6 1/2" x 8" x 1", 640 Wheel Wagons
	GD9728	-	Cover, 6 1/2" x 8" x 1 3/4", 840 Wheel And 840/1040 Row Crop Wagons
	GD10716	-	Cover, 14" x 6 1/4" x 1 3/4", UTC
3.	G7701X	1	EZ 2000 Indicator W/Serial Port For Printer, FACTORY CALIBRATION REQUIRED - Specify Wagon Type And Size, 640/840 Wheel Wagons, 840/1040 Row Crop Wagons And UTC
	GR1175	-	Plastic Housing (Not Shown)
4.	GD7826	1	Mounting Bracket
5.	G10023	4	Hex Head Cap Screw, 1/4"-20 x 3/4"
	G10110	4	Lock Nut, 1/4"-20
6.	G10522	-	Slotted Hex Self-Tapping Screw, 1/4"-20 x 3/4"
7.	GD6291	-	Insulated Clamp, 3/8"
8.	GA4683	1	Cable Extension (To Junction Box Cable)
9.	GA6772	1	Battery Power Cable
10.	7383X	-	Optional Printer W/Data Cable And Power Cable, For Use With EZ-210, EZ 150 And EZ 2000 Printer Ready Indicators <b>(Non-Stock Item - Order Through KINZE® Wholegoods)</b>
	GR1491	-	Data Cable (Used Between Indicator And Printer)
	GR1492	-	Power Cable
11.	GA8606	1	Memory Converter (Used Between Indicator And Downloader Module)
12.	GA8605	1	Downloader Module
13.	GD11586	1	Program Diskette
14.	GA8612	1	Interface Cable (Used Between Downloader Module And PC Printer Port)
15.	GD7138	-	Cover, 28", Wheel And Row Crop Wagons
	GD7139	-	Cover, 20", Wheel And Row Crop Wagons
16.		-	See "Weigh Axle, 640/840 Wheel Wagon", Page P34 Or "Axle, 840/1040 Row Crop Wagon", Page P35
17.		-	See "Hitch Cap/Plate", Page P41
18.	G10012	4	Hex Head Cap Screw, 5/8"-11 x 6 1/2"
	G10107	4	Lock Nut, 5/8"-11
19.	GA7895	4	Load Cell, UTC
20.	G10048	8	Hex Head Cap Screw, 3/8"-16 x 2", UTC (Load Cell Retainer)
	G10108	8	Lock Nut, 3/8"-16 (Load Cell Retainer)
21.	GD10682	-	Load Cell Retainer
22.	GD10359	8	Bushing, UTC (Load Cell Retainer)
23.	GR1067	-	Pin
24.	GR1171	-	Female Socket Contact
25.	GR1068	-	Connector, Male
26.	GR1170	-	Connector, Female
27.	GR1069	-	Shrink Tube, 2 1/2"

# SAFETY/WARNING AND WORK LIGHTS

ECP010/WAC017(WGN51d/WGN51e/WGN67a)

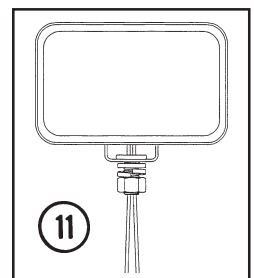
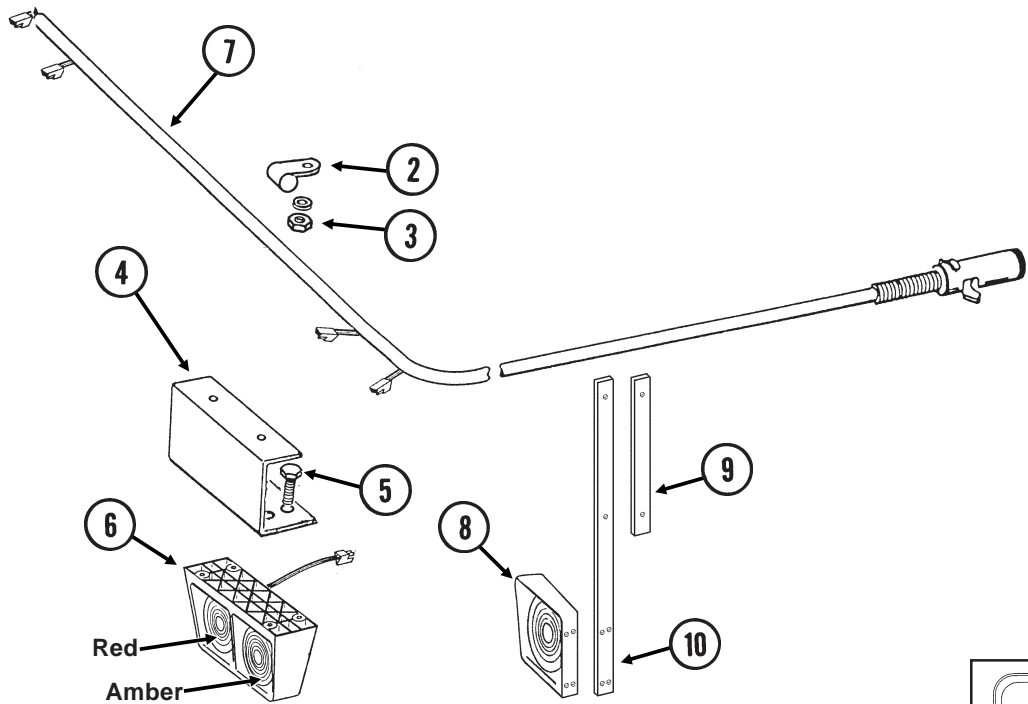
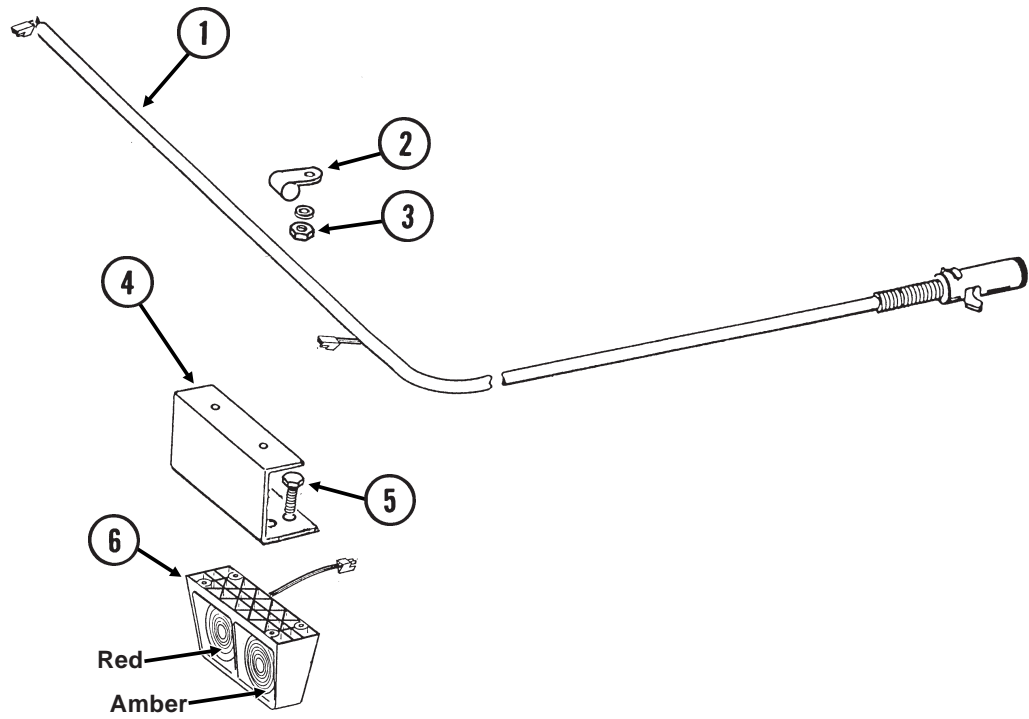

# SAFETY/WARNING AND WORK LIGHTS

---

ITEM	PART NO.	QTY.	DESCRIPTION
1.	GA7583	1	Wiring Harness W/7 Terminal Female Connector, 640
	GA7584	-	Wiring Harness W/7 Terminal Female Connector, 840/1040
	GA5385	-	7 Terminal Female Connector
2.	GD6291	-	Insulated Clamp, 3/8"
3.	G10229	-	Lock Washer, 3/8"
	G10101	-	Hex Nut, 3/8"-16
4.	GD9425	2	Mount
5.	G10064	8	Hex Head Cap Screw, 1/4"-20 x 1"
	G10110	8	Lock Nut, 1/4"-20
6.	GA6700	1	Double Light Assembly (Shown)
	GA6699	1	Double Light Assembly
	GR1203	-	Red Lens
	GR1204	-	Amber Lens
	GR1205	-	Cover
	GR1206	-	Rubber Grommet (4)
	GR1207	-	Lamp Unit
	GR1208	-	Bulb
	7.	GA9117	1
GA9116		-	Light Wiring Harness W/7 Terminal Female Connector, 840/1040
GA5385		-	7 Terminal Female Connector
8.	GA6701	2	Single Light Assembly
	GR1204	-	Amber Lens
	GR1206	-	Rubber Grommet (2)
	GR1207	-	Lamp Unit
	GR1208	-	Bulb
9.	GD12833	2	Bracket Cap
10.	GD12832	2	Light Bracket
11.	GA7581	2	Flood Light Subassembly W/Lamp
	GR1360	1	Lamp, 50W Halogen
A.	G1K328	-	Safety/Warning Light Package (Items 2-10)

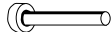

# DECALS, PAINT AND MISCELLANEOUS

GRAIN FLOW CONTROL GATE INDICATOR	
RETRACTED  CLOSED	EXTENDED  OPEN

7100-19

1



2

## WARNING

1. Read and understand the Operator's Manual.
2. Stop the tractor engine before leaving the operator's platform.
3. Keep riders off the machine.
4. Make certain everyone is clear of the machine before starting the tractor engine and operating.
5. Keep all shields in place.
6. Never lubricate, adjust, unclog or service the machine with tractor engine running.
7. Wait for all movement to stop before servicing.
8. Keep hands, feet and clothing away from moving parts.
9. Use flashing warning lights when operating on highways except when prohibited by law.

7100-46

3

# KINZE

4

## WARNING

**TOW ONLY WITH FARM TRACTOR**

7100-56

5

## DANGER



**ROTATING DRIVELINE CONTACT CAN CAUSE DEATH KEEP AWAY!**

**DO NOT OPERATE WITHOUT-**

- ALL DRIVELINE GUARDS, TRACTOR AND EQUIPMENT SHIELDS IN PLACE
- DRIVELINES SECURELY ATTACHED AT BOTH ENDS
- DRIVELINE GUARDS THAT TURN FREELY ON DRIVELINE

6

## WARNING

NEVER OPERATE PTO SHAFT ABOVE 1000 PTO RPM. NEVER RUN WAGON AUGERS AT FULL RPM WHEN EMPTY.

7100-79

7

## DANGER

HYDRAULIC FOLDING AUGER

**FAILURE TO HEED THIS WARNING MAY RESULT IN PERSONAL INJURY OR DEATH.**

KEEP CLOTHING, YOURSELF AND OTHERS WELL CLEAR WHEN FOLDING AND UNFOLDING AUGER.

7100-81

9

## DANGER

FAILURE TO HEED THESE WARNINGS MAY RESULT IN **PERSONAL INJURY OR DEATH.** NEVER ALLOW ANYONE ON OR IN WAGON WHILE OPERATING. ALWAYS UNHOOK WAGON FROM TRACTOR WHEN PERFORMING REPAIRS INSIDE OF WAGON. ALL NORMAL MAINTENANCE CAN BE PERFORMED WITHOUT CLIMBING INSIDE OF WAGON.

WAGON IS INTENDED FOR FIELD USE ONLY. TOW ONLY WITH FARM TRACTOR. ALWAYS OBEY ALL LAWS AND LOAD LIMITS WHEN TRANSPORTING.

7100-82

10

## WARNING

NEVER OPERATE WAGON WHEN INSPECTION COVER IS REMOVED.

7100-80

8

## INSTRUCTION

TIGHTEN WHEEL NUTS TO 425 FOOT-POUNDS TORQUE AND CHECK PERIODICALLY. MAINTAIN TIRE PRESSURE AT 35 MIN.-40 MAX. PSI. LUBRICATE AUGER HINGE, PTO SHAFT AND DRIVE CHAINS DAILY. SEE OPERATOR'S MANUAL FOR ADDITIONAL MAINTENANCE TO BE PERFORMED ANNUALLY.

7100-85

11

## DANGER



SHIELD MISSING DO NOT OPERATE

---

## DANGER



SHIELD MISSING DO NOT OPERATE

12

## WARNING

THIS MACHINE HAS BEEN DESIGNED AND BUILT WITH YOUR SAFETY IN MIND. DO NOT MAKE ANY ALTERATIONS OR CHANGES TO THIS MACHINE. ANY ALTERATION TO THE DESIGN OR CONSTRUCTION MAY CREATE SAFETY HAZARDS.

7100-90

13



14

# 640

15

# 840

16



WEEKLY

7100-110

18



17



DAILY

7100-111

19

## WARNING

WINDOWS GIVE ONLY A LIMITED VIEW OF WHAT IS BEHIND THE WAGON. ALWAYS CHECK CAREFULLY, INCLUDING BLIND SPOTS, BEFORE BACKING OR TURNING WAGON.

7100-112

20

## CAUTION

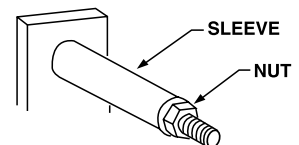

CHAIN IDLER SPRING ADJUSTMENT NUTS MUST NOT BE OVERTIGHTENED. SLEEVE AROUND SPRING MUST ALWAYS TURN FREELY BY HAND AFTER NUT IS TIGHTENED. IF SLEEVE DOES NOT TURN FREELY, LOOSEN ADJUSTMENT NUT UNTIL IT DOES.

7100-113

21

# DECALS, PAINT AND MISCELLANEOUS

**⚠ DANGER**

SERIOUS INJURY OR DEATH CAN RESULT FROM CONTACT WITH ELECTRICAL LINES. USE CARE TO AVOID CONTACT WITH ELECTRIC LINES WHEN MOVING OR OPERATING THIS MACHINE.

7100-117 **22**

**⚠ WARNING ⚠**

1. SHUT OFF PTO AND TRACTOR ENGINE.
2. OPEN BRASS VALVES LOCATED UNDER OILER TANK.
3. START TRACTOR ENGINE AND ENGAGE PTO AT IDLE FOR A SHORT TIME.
4. REMAIN ON/IN TRACTOR WHILE PTO IS RUNNING.
5. DISENGAGE PTO AND SHUT OFF TRACTOR ENGINE.
6. CLOSE BRASS VALVES LOCATED UNDER OILER TANK.

7100-118 **23**

**INFLATE TO  
35 MIN - 40 MAX PSI**

7100-119 **24**

**Electronic Scale**

**25**

**⚠ DANGER**

Do Not Tow Loaded Wagons on Public Roads and Bridges. If you must tow a loaded wagon on public roads and bridges:

1. Do not exceed 10 mph.
2. Check operator's manual for the loaded weight of the wagon.
3. Tow only on roads and bridges capable of carrying the loaded weight of the wagon.
4. Know and obey all laws and regulations.

7100-120 **26**

*Sof-Trak* **27**



**28**

*Row Crop* **29**

**1040** **30**

**⚠ DANGER**  
FLOWING GRAIN TRAPS AND SUFFOCATES VICTIM IN SECONDS!

NEVER PLAY IN OR ON THIS WAGON!



YOU CAN DIE IN SECONDS IN FLOWING GRAIN!

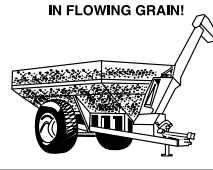

Farm Safety For "JUST KIDS" © 1988

**31**

**⚠ DANGER**

- ROTATING AUGER - NEVER OPEN OR CLOSE WITH AUGER RUNNING. WHEN OPERATING DUMP DOOR KEEP CLOTHING, YOURSELF AND OTHERS WELL CLEAR.

7100-142 **32**

**INSTRUCTIONS**

AXLE ADJUSTMENT

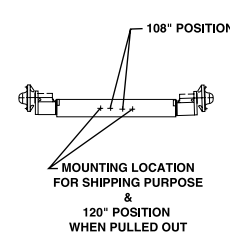

108" POSITION

MOUNTING LOCATION FOR SHIPPING PURPOSE & 120" POSITION WHEN PULLED OUT

7100-151 **34**

**⚠ DANGER**

**NEVER TRANSPORT WAGON OR LOAD WAGON WITH GRAIN WITH OUTER WHEELS REMOVED**

The two outer wheels on Row Crop wagons are removed to allow narrower width for truck shipment. Using extreme caution, unload wagon in level area. Tipping may occur because of narrow wheel base! Install outer wheels immediately.

7100-161 **35**

**⚠ DANGER ⚠**

NEVER TRANSPORT WAGON OR LOAD WAGON WITH GRAIN WITH OUTER WHEELS REMOVED

7100-162 **33**

**⚠ CAUTION**

1. Read and understand Utility Tracked Chassis Operator's Manual.
2. This Utility Tracked Chassis is designed for off road use only.
3. Never allow riders on or near the chassis while operating.
4. Do not exceed maximum gross vehicle weight or maximum towing speed indicated in operator's manual.
5. It is anticipated that modifications and attachments will be added to the chassis. KINZE Manufacturing, Inc. will not be responsible for the safety, performance, or conditions created by these modifications and attachments individually or the completed machine.

DO NOT REMOVE THIS DECAL. SHOULD DECAL BE RENDERED UNREADABLE, REPLACE IMMEDIATELY.

7100-160 **36**

**⚠ WARNING**

1. This chassis has been designed and built with your safety in mind. It is your responsibility to follow appropriate safety standards and practices to protect you and others from injury when any modifications are made or attachments are added to the chassis.
2. Wide loads or loads with high center of gravity may cause instability or rollover when operating on hillside or rough terrain.
3. Never leave towing vehicle's operating station without shutting off engine and applying parking brake.
4. Tow only with off road tractor of size and type to properly control gross weight and braking. If you must tow on public roads and bridges, you are responsible to be aware of and follow all appropriate federal, state and local laws and regulations in this regard.

**37**

**⚠ DANGER**



AVOID CONTACT WITH ELECTRICAL POWER

7100-175 **37**

**38**

# DECALS, PAINT AND MISCELLANEOUS

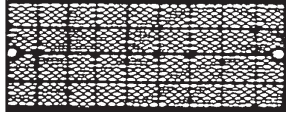

39



40



41

## NOTE

It is the responsibility of the user to read and understand the Operator's Manual in regards to safety, operation, lubrication and maintenance before operation of this equipment.

AN OPERATOR & PARTS MANUAL IS AVAILABLE FOR THIS MACHINE.

To obtain a manual, furnish model number and serial number and contact your KINZE Dealer or KINZE Manufacturing, Inc., P.O. Box 806 Williamsburg, IA 52361-0806 USA

42

ITEM	PART NO.	QTY.	DESCRIPTION
1.	G7100-19	1	Decal, Grain Flow Indicator
2.	G7100-36	1	SMV Sign
3.	G7100-46	1	Decal, Warning
4.	G7100-54	2	Decal, KINZE®, 4 3/16" x 17 3/16"
5.	G7100-56	1	Decal, Warning
6.	G7100-67	1	Decal, Danger
7.	G7100-79	1	Decal, Warning
8.	G7100-80	2	Decal, Warning
9.	G7100-81	1	Decal, Danger
10.	G7100-82	1	Decal, Danger
11.	G7100-85	1	Decal, Instructions
12.	G7100-86	1	Decal, Danger
13.	G7100-90	1	Decal, Warning
14.	G7100-93	-	White Striping, 3" x 100 Yards
	GR1172-01	-	White Striping, Per Foot
15.	G7100-105	2	Decal, 640
16.	G7100-106	2	Decal, 840
17.	G7100-107	2	Decal, KINZE® Logo
18.	G7100-110	-	Decal, Grease Weekly
19.	G7100-111	-	Decal, Oil Daily
20.	G7100-112	1	Decal, Warning
21.	G7100-113	1	Decal, Caution
22.	G7100-117	1	Decal, Danger
23.	G7100-118	1	Decal, Warning
24.	G7100-119	2	Decal, Instruction
25.	G7100-130	2	Decal, Electronic Scale
26.	G7100-120	1	Decal, Danger
27.	G7100-131	2	Decal, Sof-Trak
28.	G7100-272	2	Decal, Sof-Trak
29.	G7100-150	2	Decal, Row Crop
30.	G7100-152	2	Decal, 1040
31.	G7100-134	1	Decal, Danger
32.	G7100-142	1	Decal, Danger
33.	G7100-162	2	Decal, Danger, Row Crop Wagon
34.	G7100-151	1	Decal, Instructions, Wheel Wagon
35.	G7100-161	1	Decal, Danger, Row Crop Wagon
36.	G7100-180	1	Decal, Caution/Warning, UTC
37.	G7100-175	2	Decal, Danger
38.	GD1512	-	Tie Strap, 7 1/2"
	GD2117	-	Tie Strap, 14 1/2"
39.	G7200-03	4	Reflector, Red (If Applicable)
	G7200-04	2	Reflector, Amber (If Applicable)
40.	G7100-258	-	Reflective Decal, Red, 1 1/2" x 9", Rectangular (If Applicable)
	G7100-259	-	Reflective Decal, Amber, 1 1/2" x 9", Rectangular (If Applicable)
	G7100-260	-	Reflective Decal, Orange, 1 1/2" x 9", Rectangular (If Applicable)
41.	GR0155	-	Blue Paint, Aerosol Can (Shown)
	GR0155MPP	-	Blue Paint, Twelve Aerosol Cans
42.	G7100-217	-	Decal, Note

# NUMERICAL INDEX

Part No.	Page	Part No.	Page	Part No.	Page
7383X	P51	G10049	P7, P9, P48, P49	G10216	P17, P19, P21, P23, P25, P32, P33, P38
A1014	P17, P31	G10050	P42	G10217	P15, P19, P25
A1015	P17	G10054	P37	G10218	P19, P21, P23, P25
A1016	P31	G10055	P21, P23, P25	G10219	P15, P17
A1017	P31	G10056	P33, P41	G10228	P11, P15, P17, P19, P21, P23, P24, P25, P26, P27, P29, P32, P33, P34, P36, P38
A1079	P31	G10058	P19, P21, P23	G10229	P15, P17, P27, P29, P31, P32, P33, P53
A1111	P15, P29	G10060	P3, P5	G10230	P15, P17, P19, P21, P23, P25, P27, P48, P49
A1112	P15	G10064	P53	G10231	P12, P13, P17, P21, P25, P31, P33, P36
A1137	P29	G10072	P13, P21, P26	G10232	P15, P17
A4187	P45	G10080	P12, P13, P19, P21, P23, P25, P27	G10233	P19, P21, P24
A4192	P43	G10082	P38	G10234	P12, P35
A4756	P46	G10087	P15, P17	G10236	P39, P40, P41, P43
A5476	P38	G10101	P15, P17, P27, P29, P31, P32, P33, P53	G10238	P43
A5477	P38	G10102	P15, P17, P23, P24, P26, P27, P29, P32, P33, P38	G10239	P43
A5574	P40	G10104	P15, P17, P19, P21, P23, P25, P27, P48, P49	G10318	P25, P27
A8775	P45, P46	G10105	P17, P31, P33, P36	G10326	P7, P9
A8822	P44	G10106	P15, P17	G10330	P42
A8824	P47	G10107	P12, P13, P15, P17, P19, P21, P23, P25, P26, P27, P34, P51	G10336	P35
A9606	P38	G10108	P2, P4, P6, P7, P8, P9, P12, P13, P29, P31, P48, P49, P51	G10343	P35
D10044	P40	G10109	P3, P5	G10359	P13, P21
D10909	P37	G10110	P35, P51, P53	G10360	P13, P21, P42
D11012	P37	G10111	P17, P26, P29, P31	G10373	P37
D11013	P37	G10112	P19, P21, P23, P25, P35, P42	G10396	P35, P42
D11899	P37	G10117	P34, P36	G10400	P25, P35
D4093	P37	G10120	P12, P19, P23, P25, P27	G10402	P35
D7640	P40	G10121	P10	G10423	P19, P21, P23, P25, P26
D8495	P37	G10122	P11	G10426	P15, P17
D9307	P40	G10123	P11	G10434	P15, P17
D9308	P40	G10124	P11	G10438	P19, P21, P23, P25
G10001	P2, P4, P6, P8, P12, P13, P27, P32, P33	G10125	P15, P17, P26, P27	G10441	P42
G10003	P31, P32, P33	G10127	P17	G10442	P42
G10004	P19, P21, P23, P25, P29, P31	G10135	P11	G10456	P2, P3, P4, P5, P6, P8
G10005	P23, P38, P48, P49	G10139	P43	G10460	P12, P13, P15, P17
G10007	P15, P17	G10141	P19	G10461	P35
G10008	P15, P19, P21	G10142	P10, P11	G10471	P37
G10009	P25	G10143	P10	G10522	P51
G10011	P13, P17, P21, P34	G10151	P42	G10526	P19, P21, P24
G10012	P51	G10185	P26, P27	G10535	P39, P40, P41
G10013	P12, P15, P19, P23	G10198	P37	G10537	P38
G10014	P19, P34, P36, P38	G10205	P23	G10538	P38
G10016	P17	G10210	P31, P32, P33, P48, P49	G10539	P38
G10017	P15, P17, P23, P24, P27, P29, P32, P33	G10215	P19, P21, P23, P25	G10540	P34, P36
G10018	P10			G10543	P21, P25
G10019	P15, P17, P19, P23			G10556	P2, P3, P4, P5
G10023	P35, P51			G10563	P6, P8
G10025	P12, P13, P17, P31			G10610	P15, P17
G10028	P23, P33				
G10033	P26				
G10036	P26, P27				
G10037	P11				
G10039	P19, P26				
G10048	P51				

# NUMERICAL INDEX

Part No.	Page	Part No.	Page	Part No.	Page
G10625	P37	G7100-110	P56	GA0517	P27
G10640	P13, P35	G7100-111	P56	GA0529	P37
G10641	P12, P15, P17, P19, P21, P23, P25, P26, P27, P35, P36, P39, P40, P41, P42	G7100-112	P56	GA0530	P37
G10647	P42	G7100-113	P56	GA0531	P23, P37
G10648	P42	G7100-117	P56	GA0532	P37
G10694	P26	G7100-118	P56	GA0593	P19, P21, P25
G10700	P2, P3, P4, P5, P6, P7, P8, P9	G7100-119	P56	GA0624	P11
G10726	P37	G7100-120	P56	GA0685	P27
G10730	P19, P21, P23, P25	G7100-130	P56	GA0686	P31
G10743	P23	G7100-131	P56	GA0696	P31
G10749	P11	G7100-134	P56	GA0699	P11
G10763	P15, P17	G7100-142	P56	GA0713	P19
G10847	P26	G7100-150	P56	GA0714	P10
G10849	P12, P13, P19, P21, P23, P25, P27	G7100-151	P56	GA0715	P10
G10850	P12, P13, P19, P21, P23, P25, P27	G7100-152	P56	GA0779	P39, P40, P41
G10892	P12	G7100-161	P56	GA1539	P31
G10910	P2, P4, P6, P8	G7100-162	P56	GA4085	P29
G10914	P19, P21, P23, P25, P35	G7100-175	P56	GA4108	P17
G10942	P13	G7100-180	P56	GA4110	P15, P17
G10958	P47	G7100-19	P56	GA4112	P15, P17
G10967	P45, P46	G7100-217	P56	GA4115	P43
G10969	P43, P44, P47	G7100-258	P56	GA4129	P45
G1K168	P48	G7100-259	P56	GA4134	P29
G1K175	P43	G7100-260	P56	GA4135	P29
G1K200	P15	G7100-272	P56	GA4147	P26
G1K201	P17	G7100-36	P56	GA4151	P32
G1K271	P42	G7100-46	P56	GA4152	P32
G1K278	P17	G7100-54	P56	GA4155	P32
G1K297	P13	G7100-56	P56	GA4156	P32
G1K303	P12	G7100-67	P56	GA4160	P15, P17
G1K304	P13	G7100-79	P56	GA4163	P15
G1K326	P17	G7100-80	P56	GA4168	P15
G1K328	P53	G7100-81	P56	GA4171	P23
G2700-06-06	P29	G7100-82	P56	GA4174	P15, P17
G2700-08	P31	G7100-85	P56	GA4177	P23, P25
G306-06	P29	G7100-86	P56	GA4178	P19, P21
G306-08	P31	G7100-90	P56	GA4180	P19, P21, P23, P25
G3301-45	P25	G7100-93	P56	GA4182	P23, P24
G3301-47	P25	G7200-03	P56	GA4185	P29
G3301-65	P21	G7200-04	P56	GA4186	P29
G3304-51	P23	G7701X	P51	GA4188	P45
G3304-63	P19	GA0406	P10	GA4189	P15
G5503-02-02	P27	GA0423	P17	GA4193	P43
G6801-06-08	P15, P29	GA0437	P33	GA4194	P33
G6801-08	P17, P31	GA0445	P37	GA4196	P33
G7100-105	P56	GA0446	P37	GA4208	P15
G7100-106	P56	GA0447	P21, P25	GA4214	P42
G7100-107	P56	GA0448	P13, P21	GA4255	P46
		GA0449	P12, P19, P23	GA4532	P26
			P25, P27	GA4533	P26
		GA0450	P26	GA4534	P12
		GA0451	P15, P26	GA4535	P15
		GA0452	P17	GA4537	P27
		GA0504	P15, P17, P26, P27	GA4538	P13
		GA0511	P17	GA4539	P17



# NUMERICAL INDEX

Part No.	Page	Part No.	Page	Part No.	Page
GA4664	P32, P33	GA6700	P53	GD10739	P35
GA4680	P42	GA6701	P53	GD10740	P35
GA4681	P42	GA6752	P35	GD10748	P15, P26
GA4683	P51	GA6772	P51	GD10749	P17
GA4687	P34	GA6879	P40	GD10759	P35
GA4688	P32	GA6889	P39	GD11092	P40
GA4690	P19, P21, P23, P25	GA6890	P39	GD11586	P51
GA4691	P19, P21	GA6919	P27	GD11589	P13
GA4692	P21	GA9652	P38	GD11888	P47
GA4697	P31	GA9653	P38	GD11926	P43, P44, P47
GA4698	P31	GA7312	P51	GD11985	P44, P47
GA4718	P31	GA7434	P40	GD11986	P44, P47
GA4719	P31	GA7561	P42	GD12510	P46
GA4734	P19	GA7581	P53	GD12511	P46
GA4757	P46, P47	GA7583	P53	GD12832	P53
GA4999	P39, P40, P41	GA7584	P53	GD12833	P53
GA5385	P53	GA7818	P35	GD1346	P23
GA5447	P37	GA7895	P51	GD1347	P27
GA5483	P40	GA7955	P42	GD1350	P48, P49
GA5484	P40	GA7956	P42	GD13552	P41
GA5486	P39	GA8185	P36	GD13553	P41
GA5487	P39, P40, P41	GA8192	P31	GD1357	P21, P25
GA5489	P36	GA8193	P31	GD13573	P41
GA5490	P40	GA8605	P51	GD1358	P21
GA5514	P38	GA8606	P51	GD1359	P37
GA5534	P36	GA8609	P15	GD1360	P37
GA5535	P36	GA8610	P17	GD1447	P26
GA5692	P51	GA8612	P51	GD1512	P56
GA5734	P34	GA8816	P45	GD2117	P56
GA5736	P34	GA8818	P45	GD2161	P12
GA5737	P34	GA8821	P44	GD2951	P25
GA5768	P37	GA8823	P44	GD3457-04	P19
GA5769	P17	GA8825	P47	GD3457-06	P12
GA5772	P33	GA8898	P44	GD4010	P26, P27
GA5773	P17	GA8899	P44	GD4012	P17
GA5776	P33	GA8900	P47	GD4014	P15, P17
GA5778	P33	GA8901	P47	GD4016	P25
GA5779	P33	GA8920	P46	GD4061	P31
GA5780	P33	GA8921	P46	GD4077	P21, P25
GA5789	P35	GA8936	P32	GD4079	P21, P25
GA5790	P35	GA9116	P53	GD4086	P15, P17, P29, P31
GA5797	P35	GA9117	P53	GD4108	P15, P17
GA5806	P35	GA9607	P41	GD4117	P19
GA5813	P31	GB0236	P42	GD4118	P19, P23
GA5852	P27	GD0144	P6, P7, P8, P9	GD4119	P19, P23
GA5857	P31	GD0147	P2, P3, P4, P5, P19	GD4120	P23
GA5858	P31	GD0148	P19, P23, P25	GD4121	P19
GA5859	P31	GD0327	P32, P33	GD4123	P23, P25
GA5860	P31	GD0653	P13	GD4173	P33
GA6022	P42	GD10045	P40	GD4525	P43
GA6025	P42	GD10136	P38	GD4632	P45
GA6030	P49	GD10359	P51	GD5892	P15
GA6093	P42	GD10500	P29	GD5949	P45
GA6128	P37	GD10682	P51	GD5954	P46
GA6699	P53	GD10716	P51	GD5956	P46



# NUMERICAL INDEX

Part No.	Page	Part No.	Page	Part No.	Page
GD6279-04	P15, P17	GD9602-01	P33	GR0332	P10
GD6291	P51, P53	GD9602-02	P33	GR0333	P10
GD6307	P29	GD9728	P51	GR0334	P10
GD6308	P29	GD9777	P40	GR0335	P10
GD6309	P29	GD9778	P40	GR0336	P10
GD6323	P15, P17	GD9820	P25	GR0338	P10
GD6337	P19, P21, P23, P25	GD9821	P25	GR0339	P10
GD6388	P12	GD9900	P38	GR0340	P10
GD6392	P23	GR0155	P56	GR0341	P10
GD6408	P19	GR0155MPP	P56	GR0342	P2, P4
GD6417	P15	GR0190	P10	GR0343	P2, P4
GD6420	P12	GR0191	P37	GR0344	P2, P4
GD6425-01	P19, P23, P25	GR0192	P37	GR0345	P2, P4
GD6425-03	P19	GR0193	P29, P31	GR0347	P2, P4
GD6433	P12, P13	GR0197	P19, P23	GR0361	P23
GD6447	P29	GR0198	P21, P25	GR0449	P49
GD6460	P32, P33	GR0202	P19, P23	GR0689	P49
GD6461-01	P32, P33	GR0206	P21, P25	GR0690	P49
GD6461-02	P32, P33	GR0238	P6, P8	GR0691	P48, P49
GD6462	P12, P13	GR0239	P6, P8	GR0692	P48, P49
GD6487	P32, P33	GR0240	P6, P8	GR0693	P48, P49
GD6885	P21	GR0241	P6, P8	GR0694	P48, P49
GD6978	P32, P33	GR0242	P6, P8	GR0696	P49
GD6985	P29	GR0254	P2, P6	GR0698	P48, P49
GD6996	P34, P35	GR0256	P40	GR0700	P48, P49
GD7008	P51	GR0257	P37, P40	GR0702	P48, P49
GD7069	P13	GR0258	P21	GR0703	P48, P49
GD7071	P31	GR0259	P21, P25	GR0704	P48, P49
GD7096	P38	GR0264	P13, P21	GR0927	P45, P45
GD7138	P51	GR0265	P12, P19, P23, P25, P27	GR0930	P46, P47
GD7139	P51	GR0266	P26	GR0959	P45
GD7451	P39, P40, P41	GR0291	P11	GR0962	P29, P31
GD7452	P39, P40, P41	GR0292	P11	GR0963	P43, P44
GD7460	P39, P40, P41	GR0293	P11	GR0965	P15
GD7489	P40	GR0294	P11	GR0966	P12
GD7521	P38	GR0295	P11	GR0967	P15
GD7538	P34, P36	GR0296	P11	GR0974	P48
GD7585-06	P35	GR0297	P11	GR0976	P48
GD7594	P40	GR0298	P11	GR0977	P48
GD7826	P51	GR0299	P11	GR0986	P46
GD8017	P13	GR0300	P11	GR1008	P48
GD8037	P35	GR0301	P11	GR1009	P48
GD8038-04	P13	GR0302	P10, P11	GR1010	P49
GD8038-05	P21	GR0303	P11	GR1011	P49
GD8119	P35	GR0304	P11	GR1037	P15, P17, P29, P31
GD8140	P35	GR0305	P11	GR1067	P51
GD8219	P27	GR0306	P10, P11	GR1068	P51
GD8221	P31	GR0307	P11	GR1069	P51
GD8225	P33	GR0323	P39	GR1170	P51
GD8279	P38	GR0323	P39, P40, P41	GR1171	P51
GD8860	P38	GR0327	P10	GR1172-01	P56
GD9221	P21, P25	GR0328	P10	GR1174	P12, P19, P23, P25, P27
GD9425	P53	GR0329	P10	GR1175	P51
GD9592	P12, P13, P33	GR0330	P10	GR1203	P53
GD9594	P35	GR0331	P10	GR1204	P53

# NUMERICAL INDEX

Part No.	Page	Part No.	Page	Part No.	Page
GR1205	P53	GR1338	P3, P5		
GR1206	P53	GR1339	P3		
GR1207	P53	GR1340	P3		
GR1208	P53	GR1341	P3		
GR1209	P7	GR1342	P5		
GR1210	P7, P9	GR1343	P3, P5		
GR1211	P7, P9	GR1360	P53		
GR1212	P7, P9	GR1376	P12, P19, P23, P25, P27		
GR1213	P7, P9	GR1430	P2, P3, P4, P5, P6, P7, P8, P9		
GR1214	P7, P9	GR1431	P51		
GR1215	P7, P9	GR1433	P13, P21		
GR1216	P7, P9	GR1434	P12, P19, P23, P25, P27		
GR1217	P7, P9	GR1438	P3, P5, P7, P9		
GR1218	P7, P9	GR1491	P51		
GR1219	P7, P9	GR1492	P51		
GR1220	P3, P5, P7, P9	GR1522	P44, P47		
GR1221	P3, P5, P7, P9	GR1529	P46		
GR1222	P3, P5, P7, P9	GR1556	P15		
GR1223	P9				
GR1224	P7, P9				
GR1225	P7				
GR1226	P9				
GR1227	P6				
GR1228	P6, P8				
GR1229	P6				
GR1231	P6, P8				
GR1232	P8				
GR1233	P8				
GR1234	P2, P4				
GR1235	P2, P4				
GR1236	P2				
GR1237	P2, P4				
GR1238	P2				
GR1239	P4				
GR1240	P4				
GR1243	P4, P8				
GR1245	P7				
GR1246	P5, P9				
GR1247	P6, P8				
GR1248	P21, P25				
GR1300	P3, P5, P7, P9				
GR1323	P26				
GR1324	P26				
GR1325	P13, P21				
GR1326	P13, P21				
GR1328	P5				
GR1329	P3, P5				
GR1330	P3, P5				
GR1331	P3, P5				
GR1332	P3, P5				
GR1333	P3, P5				
GR1334	P3, P5				
GR1335	P3, P5				
GR1336	P3, P5				
GR1337	P3, P5				

