

M0142

OPERATOR & PARTS MANUAL

40 SERIES GRAIN AUGER WAGONS

This manual is applicable to: 640, 840 and 1040 Grain Auger Wagons

Model: AW

Serial Number: 2433 and on

Record the model number and serial number of your grain auger wagon with date purchased:

Model Number _____

Serial Number _____

Date Purchased _____

SERIAL NUMBER

The serial number provides important information about your auger wagon and may be required to obtain the correct replacement part.

The serial number plate is located on the front right hand corner of the wagon frame. It is suggested that the serial number be recorded in the space provided above. Always provide the serial number and model number when ordering parts from your KINZE Dealer or anytime correspondence is made with KINZE Manufacturing, Inc.

58619-2



TABLE OF CONTENTS

TO THE OWNER	1-1
WARRANTY	1-2
INTRODUCTION	
General Information	2-1
SPECIFICATIONS	3-1/3-3
SAFETY PRECAUTIONS	4-1/4-2
SAFETY WARNING SIGNS	5-1/5-3
LUBRICATION	
Auger Bearings, Hinge And PTO	6-1
Chain Oiler Operation	6-1
Drive Chains	6-1
Gearbox	6-2
Lubrication Locations	6-2/6-6
Wheel Bearings	6-1
OPERATION	
Cleanout Door	7-3
Initial Preparation Of The Wagon	7-1
Optional Electronic Scale	7-4
Tractor Preparation And Hookup	7-1/7-2
Unloading	7-2
MAINTENANCE	
Auger Drive Chain Adjustment	8-2
Auger Timing	8-5
Axle Adjustment (Row Crop Wagon)	8-8
Axle Adjustment (Sof-Trak Wagon)	8-9
Axle Adjustment (Wheel Wagon)	8-9
Inside Tire Repair Or Removal (Row Crop Wagon)	8-7
Mounting Bolts And Hardware	8-1
Mud Scraper Adjustment (Sof-Trak Wagon)	8-5
Optional Electronic Scale	8-9/8-11
Preparation For Storage	8-13
Shear Bolt Protection	8-3/8-4
Tire Pressure	8-4
Tire Repair (Sof-Trak Wagon)	8-6
Torque Values Chart	8-1
Track Alignment (Sof-Trak Wagon)	8-6
Track Tension (Sof-Trak Wagon)	8-5
Vertical Auger Fold	8-2
Wheel Bearing Replacement	8-12/8-13
Wheel Nuts	8-4
Wiring Diagram	8-3
PARTS LIST INDEX	P1
PARTS SECTION NUMERICAL INDEX	a

PREDELIVERY/DELIVERY CHECK LIST

TO THE DEALER

Preelivery service includes assembly, lubrication, adjustment and test. This service assures that the wagon will be delivered to the customer ready for field use.

PREDELIVERY CHECK LIST

After the wagon has been completely assembled, use the following check list and inspect the wagon. Check off each item as it is found satisfactory or after proper adjustment is made.

- Wheel nuts are torqued to 425 ft. lbs. Axles adjusted from shipping position to desired operating position.
- Tires are inflated to specified PSI of air pressure.
- Chains are aligned and properly tensioned.
- All grease fittings have been lubricated, gearbox oil level checked and chain oiler filled.
- Check to be sure all safety decals are correctly located and legible. Replace if damaged.
- Check to be sure the red reflectors and amber reflectors are correctly located.
- Check to be sure SMV decal is in place and shipping cover removed.
- Check to be sure safety/warning lights are working.
- Test run the augers.
- Check auger timing (840/1040 Models). See "Auger Timing" in Maintenance Section.
- Check to be sure safety screens over horizontal augers are in place.
- Paint all parts scratched in shipment.

This wagon has been thoroughly checked and to the best of my knowledge is ready for delivery to the customer.

(Signature of Set-up Person/Date)

OWNER REGISTER

Name _____

Date Sold _____

Street Address _____

Model _____

City & State _____

Serial Number _____

DELIVERY CHECK LIST

At the time the wagon is delivered, the following check list is a reminder of very important information which should be conveyed directly to the customer. Check off each item as it is fully explained to the customer.

- Advise the customer that the durability and longevity of this or any other machine is dependent on regular maintenance as directed in the operator's manual.
- Tell the customer about all safety precautions that must be observed while using this wagon.
- Advise the customer of the specified tractor requirement for use with this wagon.
- Check axle spacing with customer to be sure axle is adjusted to desired operating width.
- Along with the customer check to be sure the red and amber reflectors and SMV decal are clearly visible with the auger wagon attached to the tractor. Check to be sure the safety/warning lights are in working condition. Tell the customer to check and follow federal, state/provincial and local regulations before towing on a road or highway.
- Along with the customer check to be sure the hitch height when attached to the tractor is sufficient to prevent severe bends in PTO U-joint angles. Check to be sure PTO is correct length for making turns and operating on uneven terrain.
- Complete Warranty And Delivery Report Form.
- Give the operator's manual to the customer and explain all operating adjustments.

To the best of my knowledge this machine has been delivered ready for field use and customer has been fully informed as to proper care and operation.

(Signature of Delivery Person/Date)

AFTER DELIVERY CHECK LIST

The following is a list of items we suggest to check during the first season of use of the equipment.

- Check with the customer as to the performance of the wagon.
- Review with the customer the importance of proper maintenance and safety precautions.
- Check for parts that may need to be adjusted or replaced.
- Retorque all wheel nuts to 425 ft. lbs.
- Check to be sure all safety shields and screens are in place.
- Check to be sure all safety decals, reflectors and the SMV sign are correctly located and legible. Replace if damaged, or missing.
- Check to be sure safety/warning lights are working.
- Check to be sure recommended lubrication procedures are being followed.

(Signature of Follow-up Person/Date)

**RETURN THIS COMPLETED FORM TO KINZE® IMMEDIATELY, along with Warranty And Delivery Report.
Retain photocopy of this form at dealership for After Delivery Check.**

Tear Along Perforation

TO THE OWNER

KINZE Manufacturing, Inc. would like to thank you for your patronage. We appreciate your confidence in KINZE® farm machinery. Your KINZE® auger wagon has been carefully designed and sturdily built to provide dependable operation in return for your investment.

This manual has been prepared to aid you in the operation and maintenance of the auger wagon and should be considered a permanent part of the machine and should remain with the machine when you sell it.

It is the responsibility of the user to read and understand the Operator's Manual in regards to safety, operation, lubrication and maintenance prior to operation of this equipment. It is the user's responsibility to inspect and service the machine routinely as directed in the Operator's Manual. We have attempted to cover all areas of safety, operation, lubrication and maintenance; however, there may be times when special care must be taken to fit your conditions.

Throughout this manual the symbol  and the words, **NOTE, CAUTION, WARNING and DANGER** are used to call your attention to important safety information. The definition of each of these terms used follows:

NOTE: Indicates a special point of information.

CAUTION: Indicates that a failure to observe can cause damage to the machine or equipment.

 **WARNING:** Indicates that a failure to observe can cause damage to the machine or equipment and/or personal injury.

 **DANGER:** Indicates that a failure to observe can cause most serious damage to the machine or equipment and/or most serious personal injury.

 **WARNING:** Some photos in this manual may show safety covers or shields removed for visual clarity. **NEVER OPERATE** the machine without all safety covers and shields in place.

NOTE: Some photos in this manual may have been taken of prototype machines. Production machines may vary in appearance.

NOTE: Some photos and illustrations in this manual show optional attachments installed. Contact your KINZE Dealer for purchase of optional attachments.

 **DANGER:** Because of load capacities on bridges and roads and because the wagon is not equipped with brakes, the wagon is not intended for hauling loads on public roadways. It is the operator's responsibility to be aware of and follow federal, state and local regulations in this regard.

WARRANTY

The KINZE Limited Warranty for your new machine is stated on the back of the retail purchaser's copy of the Warranty And Delivery Report form.

Warranty, within the warranty period, is provided as part of KINZE's support program for registered KINZE products which have been operated and maintained as described in this manual. Evidence of equipment abuse or modification beyond original factory specifications will void the warranty. Normal maintenance, service and repair is not covered by KINZE warranty.

To register your KINZE product for warranty, a Warranty And Delivery Report form must be completed by the KINZE Dealer and signed by the retail purchaser, with copies to the Dealer, to the retail purchaser and to KINZE. Registration must be completed and sent to KINZE within 30 days of delivery of the KINZE product to the retail purchaser. KINZE reserves the right to refuse warranty on serial numbered products which have not been properly registered.

Additional copies of the Limited Warranty can be obtained through your KINZE Dealer.

If service or replacement of failed parts which are covered by the Limited Warranty are required, it is the user's responsibility to deliver the machine along with the retail purchaser's copy of the Warranty And Delivery Report to the KINZE Dealer for service. KINZE warranty does not include cost of travel time, mileage, hauling or labor. Any prior arrangement made between the Dealer and the retail purchaser in which the Dealer agrees to absorb all or part of this expense should be considered a courtesy to the retail purchaser.

KINZE warranty does not include cost of travel time, mileage, hauling or labor.

INTRODUCTION

This manual has been written to cover the 640, 840 and 1040 Model KINZE Auger Wagons.

The information and photos used in this manual were current at the time of printing. However, due to KINZE's continual attempt to improve its product, possible on-line production changes may cause your machine to appear slightly different in detail. KINZE Manufacturing, Inc. reserves the right to change specifications or design without notice and without incurring obligation to install the same on machines previously manufactured.

Right hand and left hand as used throughout this manual is determined by facing in the direction the machine will travel when in use.



640 Wheel Wagon

53881-12



640 Sof-Trak Wagon

62181-2



840 Wheel Wagon

CN840



840 Sof-Trak Wagon

59577-10



840 Row Crop Wagon



1040 Row Crop Wagon

INTRODUCTION

SPECIFICATIONS

RH490

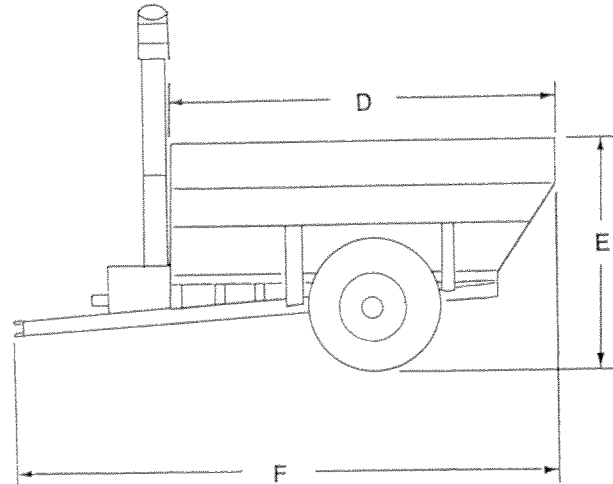
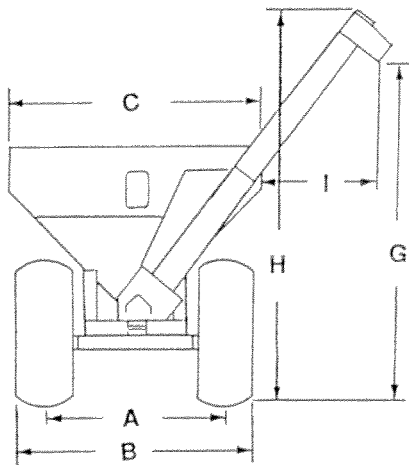

MODEL	640 Wheel	840 Wheel
(A) Tire Center To Center(Adjustable)	108" or 120"	108" or 120"
(B) Transport Width, 108" Axle	11' 0" (24.5" x 32" Tires)	11' 6"
Transport Width, 120" Axle	12' 0" (24.5" x 32" Tires)	12' 6"
(C) Width - Grain Tank	10' 0"	10' 0"
(D) Length - Grain Tank	16' 0"	20' 0"
(E) Height - Grain Tank	9' 2"	9' 6"
(F) Total Length	23' 2"	27' 0"
(G) Height - Auger Discharge	12' 3"	11' 10"
(H) Height - Top Of Auger	15' 0"	15' 5"
(I) Side Of Wagon To Tip Of Spout	4' 7"	5' 0"
Wagon Weight - Empty	8122 Lbs.	11,634 Lbs.
Hitch Weight - Empty	1760 Lbs.	2200 Lbs.
Hitch Weight - Loaded	3920 Lbs.	5950 Lbs.
Total Capacity*	625 Bu.	825 Bu.
Bushels/Minute - Max.*	210 Bu./Min.	290 Bu./Min.
Vertical Auger	14" Full Pitch R.H.	16" Full Pitch R.H.
Horizontal Auger	12" Full Pitch L.H.	12" Full Pitch L.H.
Front	12"-2/3 Pitch L.H.	12"-2/3 Pitch L.H.
Rear	3/8" Helicoid	3/8" Helicoid
Flighting	12"-14"	7/16" Helicoid
	16"	-
Gearbox	A-11 Heavy Duty	A-76 Heavy Duty
Chain	No. 80 Roller	Double No. 80 Roller
Sprockets	Industrial Grade With Tapered Lock Bushings	
Bearings	1 1/2" - 2"	2" - 2 7/16"
PTO - 1000 RPM (U-Joint W/Shaft Shear)	80 HP Rated	160 HP Rated
PTO Yoke	1 3/8"-21 Spline or 1 3/4"-20" Spline	
Hydraulic Flow Control	Standard	Standard
Tires (NOTE: 30.5" x 32" tire on 640 wagon requires 120" axle setting.)	**24.5" x 32" 12 Ply (2)	**30.5" x 32" 12 Ply (2)
	**30.5" x 32" 12 Ply (2)	-
Spindle/Hub	4 1/2" - 10 Bolt (2)	4 1/2" - 10 Bolt (2)
Hitch Clevis	Bolt-on Single Or Double Clevis - All Models	
Windows	Standard Front And Rear - All Models	
Chain/Oiler/Lube Bank	Standard	Standard
Parking Jack	7,000 Lb. Drop Leg	10,000 Lb. Drop Leg
Lights	Rear Mtd. Safety/Warning W/SAE Std. Connector	
Scale Option	Factory Or Field Installation	
Tractor Requirement (Minimum)	125 - 175 HP	175 HP 2WD/4WD

* Approximate with 15% moisture corn. Bushels and bushels/minute will vary with moisture content of grain and/or RPM.

** R-1 traction-tread or R-3 diamond-tread.

SPECIFICATIONS

RH490

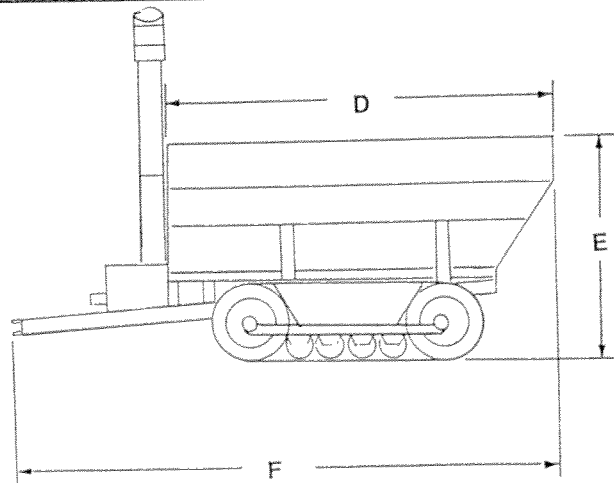
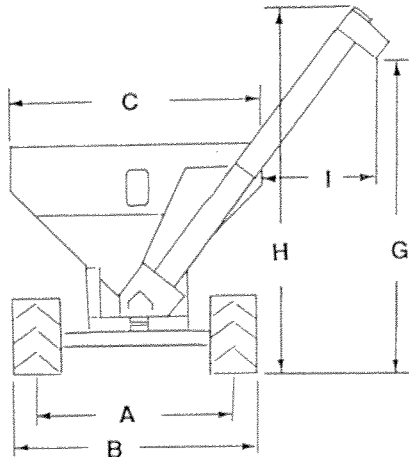

MODEL	640 Sof-Trak	840 Sof-Trak
(A) Track Center To Center(Adjustable)	108" or 120"	108" or 120"
(B) Transport Width, 108" Axle	11' 9"	11' 9"
Transport Width, 120" Axle	12' 9"	12' 9"
(C) Width - Grain Tank	10' 0"	10' 0"
(D) Length - Grain Tank	16' 0"	20' 0"
(E) Height - Grain Tank	9' 2"	9' 6"
(F) Total Length	23' 2"	27' 0"
(G) Height - Auger Discharge	12' 3"	11' 10"
(H) Height - Top Of Auger	15' 0"	15' 5"
(I) Side Of Wagon To Tip Of Spout	4' 7"	5' 0"
Wagon Weight - Empty	15,103 Lbs.	18,245 Lbs.
Hitch Weight - Empty	1760 Lbs.	2200 Lbs.
Hitch Weight - Loaded	3920 Lbs.	5950 Lbs.
Total Capacity*	625 Bu.	825 Bu.
Bushels/Minute - Max.*	210 Bu./Min.	290 Bu./Min.
Vertical Auger	14" Full Pitch R.H.	16" Full Pitch R.H.
Horizontal Auger	12" Full Pitch L.H.	12" Full Pitch L.H.
Flighting	12"-14"	12"-2/3 Pitch L.H.
	16"	3/8" Helicoid
		7/16" Helicoid
Gearbox	A-11 Heavy Duty	A-76 Heavy Duty
Chain	No. 80 Roller	Double No. 80 Roller
Sprockets	Industrial Grade With Tapered Lock Bushings	
Bearings	1 1/2" - 2"	2" - 2 7/16"
PTO - 1000 RPM (U-Joint W/Shaft Shear)	80 HP Rated	160 HP Rated
PTO Yoke	1 3/8"-21 Spline or 1 3/4"-20" Spline	
Hydraulic Flow Control	Standard	Standard
Track		
	Width	24"
	Length - Overall	153"
	Length - Contact	108"
	End Wheels	**8.25" x 20" (8)
	Mid Wheels	16" Steel (8)
Hitch Clevis	Bolt-on Single Or Double Clevis - All Models	
Windows	Standard Front And Rear - All Models	
Chain/Oiler/Lube Bank	Standard	Standard
Parking Jack	7,000 Lb. Drop Leg	10,000 Lb. Drop Leg
Lights	Rear Mtd. Safety/Warning W/SAE Std. Connector	
Scale Option	Not Available	Not Available
Tractor Requirement (Minimum)	125 - 175 HP	175 HP 2WD/4WD

* Approximate with 15% moisture corn. Bushels and bushels/minute will vary with moisture content of grain and/or RPM.

** Smooth or treaded truck tire.

SPECIFICATIONS

RH490

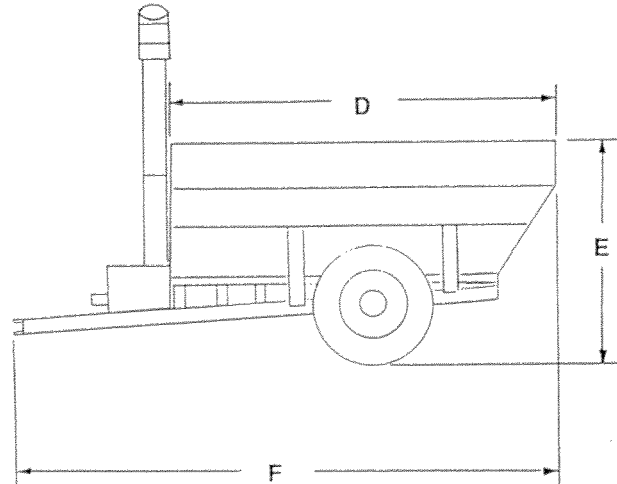
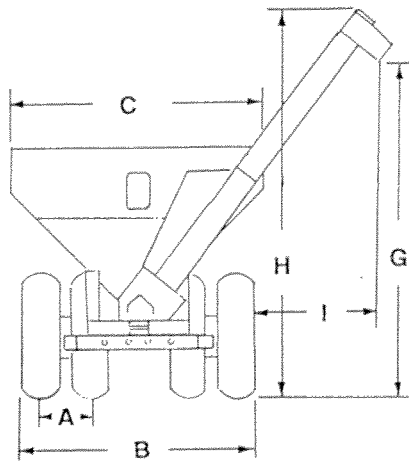

MODEL	840 Row Crop	1040 Row Crop
(A) Tire Center To Center(Adjustable)**	30" or 34 1/2"	30" or 34 1/2"
(B) Transport Width, 30" Row	11' 9"	11' 9"
Transport Width, Wide Row	13' 11"	13' 11"
(C) Width - Grain Tank	10' 0"	11' 0"
(D) Length - Grain Tank	20' 0"	20' 0"
(E) Height - Grain Tank	9' 8"	10' 8"
(F) Total Length	27' 0"	27' 0"
(G) Height - Auger Discharge	11' 10"	11' 10"
(H) Height - Top Of Auger	15' 5"	15' 5"
(I) Side Of Tire To Tip Of Spout	30" Row 4' 6"	4' 6"
	Wide Row 3' 3"	3' 3"
Wagon Weight - Empty	15,640 Lbs.	15,780 Lbs.
Hitch Weight - Empty	2200 Lbs.	2640 Lbs.
Hitch Weight - Loaded	5950 Lbs.	7240 Lbs.
Total Capacity*	810 Bu.	970 Bu.
Bushels/Minute - Max.*	290 Bu./Min.	290 Bu./Min.
Vertical Auger	16" Full Pitch R.H.	16" Full Pitch R.H.
Horizontal Auger	Front 12" Full Pitch L.H.	12" Full Pitch L.H.
	Rear 12"-2/3 Pitch L.H.	12"-2/3 Pitch L.H.
Flighting	12" 3/8" Helicoid	3/8" Helicoid
	16" 7/16" Helicoid	7/16" Helicoid
Gearbox	A-76 Heavy Duty	A-76 Heavy Duty
Chain	Double No. 80 Roller	Double No. 80 Roller
Sprockets	Industrial Grade With Tapered Lock Bushings	
Bearings	2" - 2 7/16"	2" - 2 7/16"
PTO - 1000 RPM (U-Joint W/Shaft Shear)	160 HP Rated	160 HP Rated
PTO Yoke	1 3/8"-21 Spline or 1 3/4"-20" Spline	
Hydraulic Flow Control	Standard	Standard
Tires	***18.4" x 38" 10 Ply (4)	***18.4" x 38" 10 Ply (4)
Spindle/Hub	4 1/2" - 10 Bolt (4)	4 1/2" - 10 Bolt (4)
Hitch Clevis	Bolt-on Single Or Double Clevis - All Models	
Windows	Standard Front And Rear - All Models	
Chain/Oiler/Lube Bank	Standard	Standard
Parking Jack	10,000 Lb. Drop Leg	10,000 Lb. Drop Leg
Lights	Rear Mtd. Safety/Warning W/SAE Std. Connector	
Scale Option	Factory Or Field Installation	
Tractor Requirement (Minimum)	175 HP 2WD/4WD	225 HP 4WD

* Approximate with 15% moisture corn. Bushels and bushels/minute will vary with moisture content of grain and/or RPM.

** Duals may be adjusted to center over 30" or wide rows.

*** R-1 traction-tread.

SAFETY PRECAUTIONS

Safe and careful operation of the tractor and auger wagon at all times will contribute significantly to the prevention of accidents.

Since a large portion of farm accidents occur as a result of fatigue or carelessness, safety practices should be of utmost concern. Read and understand the instructions provided in this manual. Listed below are a few other safety suggestions that should become common practice.

 Always disengage PTO and shut off tractor engine before:

1. Leaving tractor seat.
2. Lubricating the auger wagon.
3. Cleaning out debris.

 Always keep hands, feet and clothing away from moving parts.

 Make certain tractor is in safe operating condition with adequate braking capabilities, especially when operating on uneven terrain.

 Never operate the auger wagon without PTO guards, tractor master shield and implement guards in place. Make certain PTO guards turn freely and are properly attached.

 Always make certain U-joint yokes are securely locked on tractor and implement shaft before operating wagon.

 Grease telescoping PTO shaft regularly to minimize thrust forces.

 Never exceed 1000 PTO RPM or operate the PTO at full RPM with the augers empty.

 Always use adequate lights or safety warnings when transporting the wagon on public roads and after dark. Check with local law enforcement agencies for specific requirements.

 Always make certain there is adequate overhead clearance before folding or unfolding the unloading auger.

 Limit towing speed to 15 MPH when empty and 10 MPH when loaded.

 Never permit any persons other than the operator to ride on the tractor and never permit persons to ride on or in the wagon at any time.

 Always fold unloading auger to down position before transporting wagon.

 This machine has been designed and built with your safety in mind. Any alteration to the design or construction may create safety hazards. Do not make any alterations or changes to the equipment, but if any alterations or changes are made you must follow all appropriate safety standards and practices to protect you and others near this machine from injury.

 Before applying pressure to the hydraulic system, make sure all connections are tight and that hoses and fittings have not been damaged. Hydraulic fluid escaping under pressure can have sufficient force to penetrate skin, causing injury or infection.

 Because of load capacities on bridges and roads and because the wagon is not equipped with brakes, the wagon is not intended for hauling loads on public roadways. It is the operator's responsibility to be aware of and follow federal, state and local regulations in this regard.

SAFETY PRECAUTIONS



At all times keep children off of and out of auger wagon.



Rim and tire servicing can be dangerous. Explosive separation of a tire and rim parts can cause serious injury or death. The multipiece rim used on the Sof-Trak wagon requires that specific procedures and safety instruction be followed in mounting and demounting of the tires. Do not attempt to mount a tire unless you have the proper equipment and experience to perform the job. This should only be done by persons properly trained and equipped to do the job. Always maintain the correct tire pressure. Do not inflate the tires above the recommended pressure. When inflating tires, use a clip-on air chuck and extension hose long enough to allow you to stand to one side and NOT in front of or over the tire assembly. Use a safety cage to enclose the tire and rim assembly when inflating. Inspect tires and wheels daily. Do not operate with low pressure, cuts, bubbles, damaged rims or missing lug bolts and nuts.



Never transport Row Crop wagon or load Row Crop wagon with grain with outer wheels removed.



Windows give only a limited view of what is behind the wagon. Always check carefully, including blind spots, before backing or turning the wagon.

SAFETY WARNING SIGNS

The “WARNING” signs illustrated on these pages are placed on the machine to warn of hazards. “The warnings found on these signs are for your personal safety and those around you.” **OBSERVE THESE WARNINGS!**

- Keep these signs clean so they can be observed readily. Wash with soap and water or cleaning solution as required.
- Replace “WARNING” signs should they become damaged, painted over or if they are missing.
- Check the SMV decal periodically. Replace if it shows loss of any of its reflective property.
- When replacing decals, clean the machine surface thoroughly using soap and water or cleaning solution to remove all dirt and grease.

58619-21

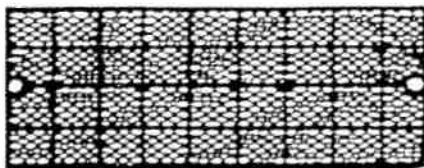
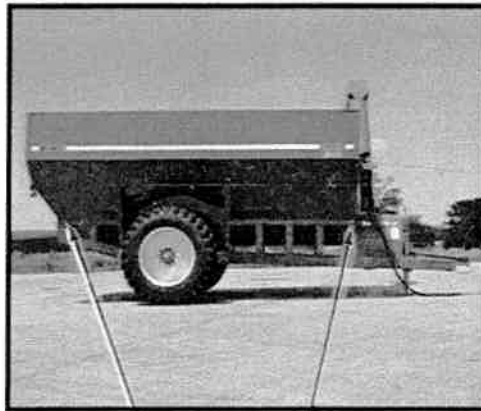

Part No. 7200-03
Red Reflector (Qty. 4)

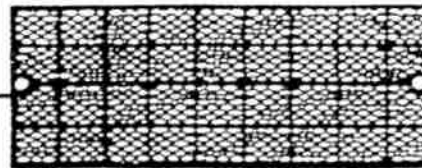

Part No. 7200-04
Amber Reflector (Qty. 2)

58619-48

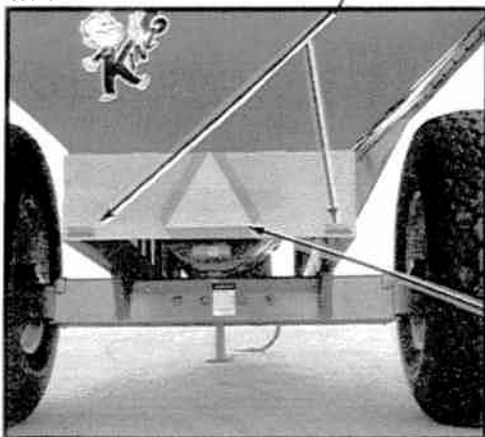

Part No. 7100-36
SMV Decal

SAFETY WARNING SIGNS

 CAUTION

1. Read and understand the Operator's Manual.
2. Stop the tractor engine before leaving the operator's platform.
3. Keep riders off the machine.
4. Make certain everyone is clear of the machine before starting the tractor engine and operating.
5. Keep all shields in place.
6. Never lubricate, adjust, unplug or service the machine with tractor engine running.
7. Wait for all movement to stop before servicing.
8. Keep hands, feet and clothing away from moving parts.
9. Use flashing warning lights when operating on highways except when prohibited by law.

Part No. 7100-46

 DANGER

HYDRAULIC FOLDING AUGER

FAILURE TO HEED THIS WARNING MAY RESULT IN PERSONAL INJURY OR DEATH.

KEEP CLOTHING, YOURSELF AND OTHERS WELL CLEAR WHEN FOLDING AND UNFOLDING AUGER.

7100-81

Part No. 7100-81

 DANGER

SERIOUS INJURY OR DEATH CAN RESULT FROM CONTACT WITH ELECTRIC LINES. USE CARE TO AVOID CONTACT WITH ELECTRIC LINES WHEN MOVING OR OPERATING THIS MACHINE.

7100-117

Part No. 7100-117

 CAUTION

WINDOWS GIVE ONLY A LIMITED VIEW OF WHAT IS BEHIND THE WAGON. ALWAYS CHECK CAREFULLY, INCLUDING BLIND SPOTS, BEFORE BACKING OR TURNING WAGON.

7100-112

Part No. 7100-112

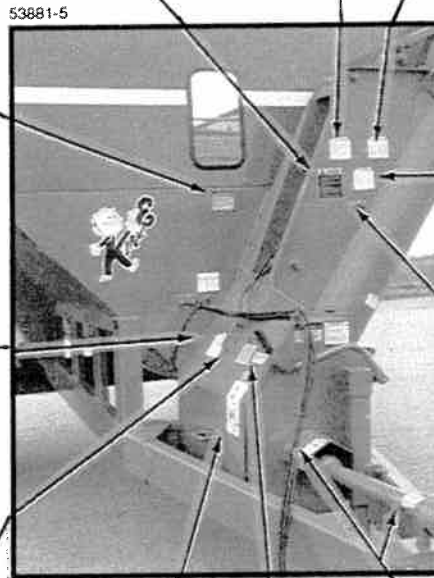

 DANGER

Do Not Tow Loaded Wagons on Public Roads and Bridges. If you must tow a loaded wagon on public roads and bridges:

1. Do not exceed 10 mph.
2. Check operator's manual for the loaded weight of the wagon.
3. Tow only on roads and bridges capable of carrying the loaded weight of the wagon.
4. Know and obey all laws and regulations.

7100-120

Part No. 7100-120

 DANGER

FAILURE TO HEED THESE WARNINGS MAY RESULT IN PERSONAL INJURY OR DEATH. NEVER ALLOW ANYONE ON OR IN WAGON WHILE OPERATING. ALWAYS UNHOOK WAGON FROM TRACTOR WHEN PERFORMING REPAIRS INSIDE OF WAGON. ALL NORMAL MAINTENANCE CAN BE PERFORMED WITHOUT CLIMBING INSIDE OF WAGON.

WAGON IS INTENDED FOR FIELD USE ONLY. TOW ONLY WITH FARM TRACTOR. ALWAYS OBEY ALL LAWS AND LOAD LIMITS WHEN TRANSPORTING.

7100-82

Part No. 7100-82

 WARNING

TOW ONLY WITH FARM TRACTOR.

Part No. 7100-56

 WARNING 

THIS MACHINE HAS BEEN DESIGNED AND BUILT WITH YOUR SAFETY IN MIND. ANY ALTERATION TO THE DESIGN OR CONSTRUCTION MAY CREATE SAFETY HAZARDS. DO NOT MAKE ANY ALTERATIONS OR CHANGES TO THE EQUIPMENT, BUT IF ANY ALTERATIONS OR CHANGES ARE MADE YOU MUST FOLLOW ALL APPROPRIATE SAFETY STANDARDS AND PRACTICE TO PROTECT YOU AND OTHERS NEAR THIS MACHINE FROM INJURY.

7100-90

Part No. 7100-90

 DANGER

FLOWING GRAIN TRAPS AND SUFFOCATES VICTIM IN SECONDS!

NEVER PLAY IN OR ON THIS WAGON





YOU CAN DIE IN SECONDS IN FLOWING GRAIN



Never Riding On



Part No. 7100-134

 WARNING 

NEVER OPERATE WAGON WHEN INSPECTION COVER IS REMOVED.

7100-80

Part No. 7100-80

 DANGER



ROTATING DRIVE LINE

DEATH CAN RESULT FROM INTANGLEMENT. KEEP PEOPLE AND CLOTHING WELL CLEAR.

DO NOT OPERATE WITHOUT:

- DRIVE LINE GUARDS
- INPUT SHAFT GUARDS
- TRACTOR MASTER SHIELD
- U JOINTS LOCKED TO TRACTOR AND IMPLEMENT SHAFTS

Part No. 7100-67

SAFETY WARNING SIGNS

58619-49

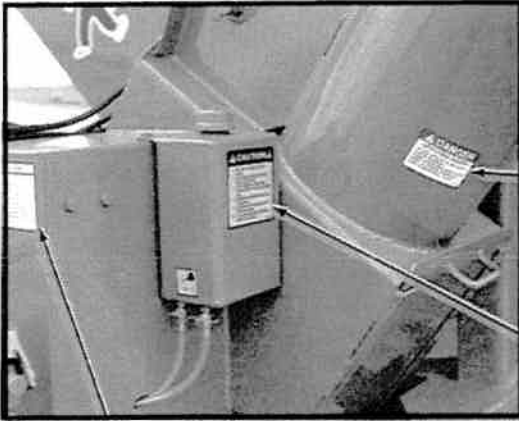

Part No. 7100-142

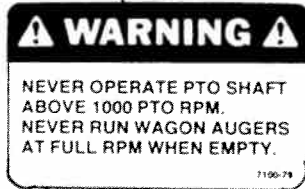

Part No. 7100-79



Part No. 7100-118

49875-20

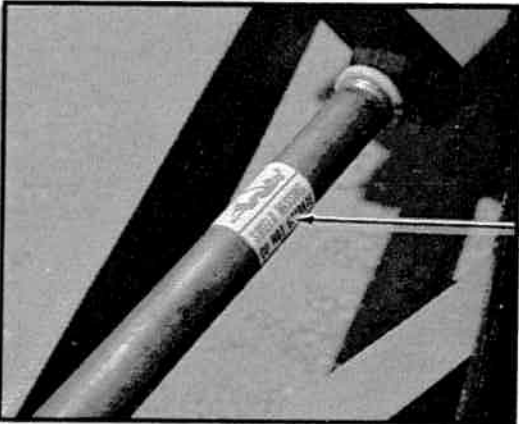

Part No. 7100-86

49735-12

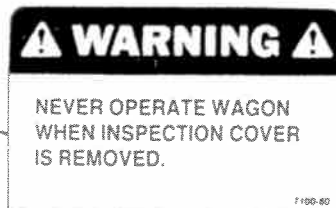

Part No. 7100-80

SAFETY WARNING SIGNS

59577-5



 **DANGER**

**NEVER TRANSPORT WAGON OR
LOAD WAGON WITH GRAIN WITH
OUTER WHEELS REMOVED**

The two outer wheels on Row Crop wagons are removed to allow narrower width for truck shipment. Using extreme caution, unload wagon in level area. Tipping may occur because of narrow wheel base! Install outer wheels immediately.

7100-161

Part No. 7100-161
Row Crop Wagon Only
(Temporary shipping warning)

59577-8

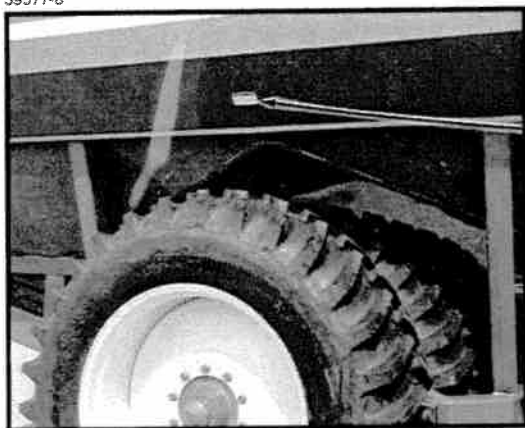

 **DANGER** 

**NEVER TRANSPORT WAGON
OR LOAD WAGON WITH
GRAIN WITH OUTER WHEELS
REMOVED**

7100-162

Part No. 7100-162
Row Crop Wagon Only
(1 on each side of wagon)

LUBRICATION

The following pages show the location of all lubrication points. Proper lubrication of all moving parts will help ensure efficient operation of your KINZE auger wagon and prolong the life of friction producing parts.

AUGER BEARINGS, HINGE AND PTO

Those parts equipped with grease fittings should be lubricated at the frequency indicated with an SAE multipurpose type grease. Be sure to clean the fitting thoroughly before using grease gun. The frequency of lubrication recommended is based on normal operating conditions. Severe or unusual conditions may require more frequent attention.

DRIVE CHAINS

58619-50



The auger wagon is equipped with a one gallon capacity chain oiler system that enables you to safely and conveniently lubricate the drive chains without removing the inspection cover. A quality engine oil or equivalent SAE 30 weight oil should be used. The chains should be lubricated at least daily or more frequently if desired, particularly under extreme operating conditions.

CHAIN OILER OPERATION:

1. Shut off PTO and tractor engine.
2. Open brass valves located under oiler tank.
3. Start tractor engine and engage PTO at idle for a short time.

! **DANGER:** Remain on/in tractor while PTO is running.

4. Disengage PTO and shut off tractor engine.
5. Close brass valves located under oiler tank.

! **DANGER:** Never turn oiler on or work around PTO, gearbox or chains and sprockets or allow anyone else to do so while PTO is running. **CAUTION:** Extreme operating conditions such as dirt, temperature or speed may require more frequent lubrication.

! **DANGER:** NEVER REACH UNDER THE WAGON TO OIL CHAINS WHILE THE CHAINS ARE MOVING. THE SPROCKETS AND CHAINS COULD PULL YOU INTO THE DRIVELINE RESULTING IN SEVERE INJURY OR DEATH!

! **DANGER:** DO NOT OPERATE WAGON WITH INSPECTION COVER REMOVED.

WHEEL BEARINGS

Wheel bearings should be checked and lubricated annually.

Raise wheel off the ground and remove the dirt cap. Check for endplay in the bearings by moving the tire in and out. Rotate the tire to check for roughness in the bearings. If bearings sound rough, the hub should be removed and the bearings inspected and replaced if necessary. See "Wheel Bearing Replacement" in the Maintenance Section of this manual.

If bearing replacement is not necessary, while the wheel is raised and the dirt cap removed, pump grease into the hub until grease comes out through the bearing rollers. Replace dirt cap.

LUBRICATION

GEARBOX

46331-8

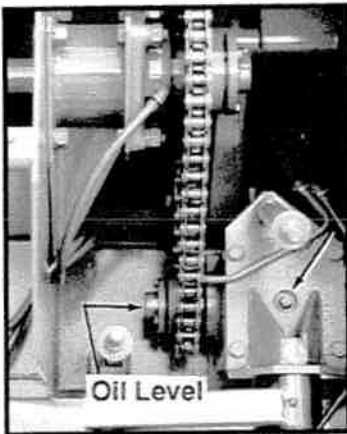

640 Models - To check oil level remove plug.

49735-10



840/1040 Models - Style A
To check oil level remove plug, elbows and nipple.

71484-2



840/1040 Models - Style B
To check oil level remove plug.

Using a clean piece of wire as a dip stick measure oil level to be sure it is **half way up** on the horizontal cross shaft. Fill as needed with SAE 90 oil.

NOTE: Oil level should never exceed more than half way up on the cross shaft.

640 MODELS

58619-47

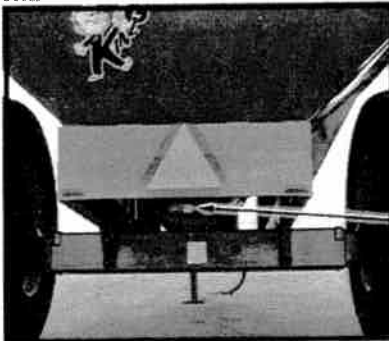

Rear Bearing (Horizontal Auger)

46331-27

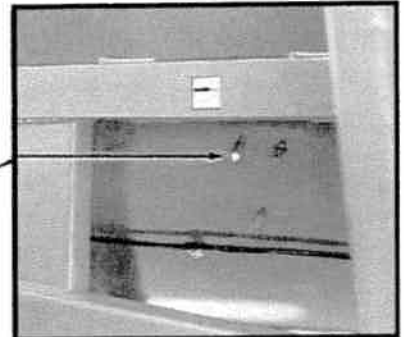

Center Bearing (Horizontal Auger)

58619-25

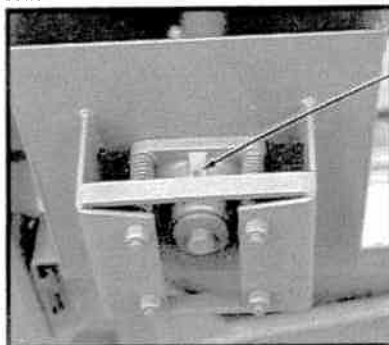

Upper Bearing (Vertical Auger)

46331-11

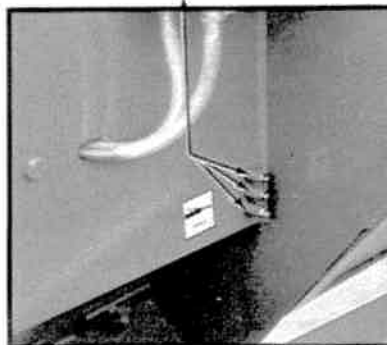

Lower Bearings (Vertical Auger)
Front Bearing (Horizontal Auger)

54813-60

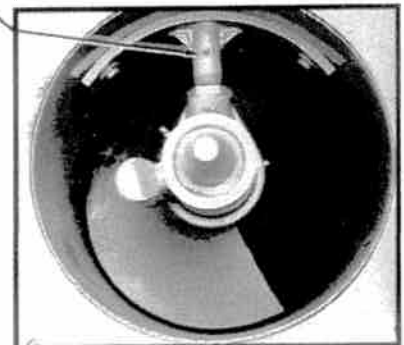

Center Bearing (Vertical Auger)



CAUTION: Extreme operating conditions such as dirt, temperature or speed may require more frequent lubrication.

LUBRICATION

58619-24

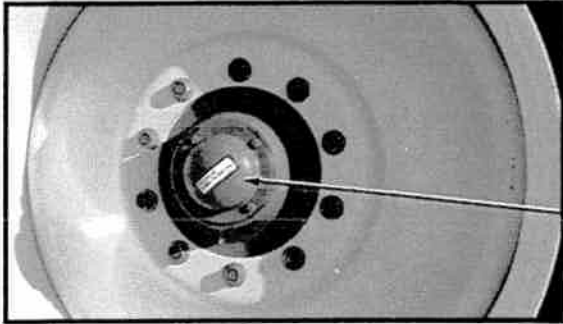

Wheel Bearings (1 Zerk Per Wheel Hub)

46331-7

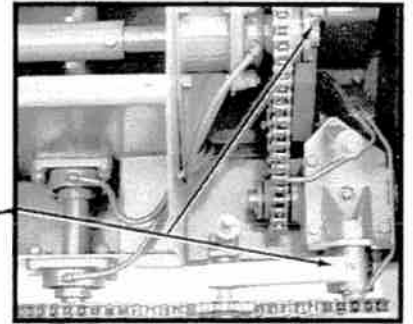

Drive Chain Idlers
(Vertical and Horizontal Augers)

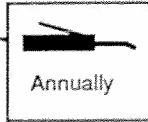

46331-7

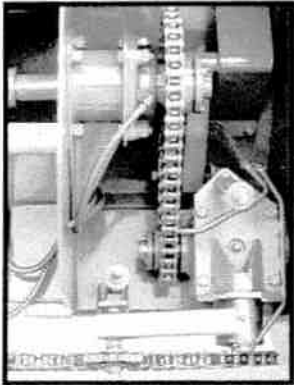

Drive Chains

58619-51

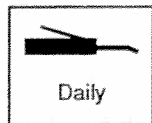

46331-34

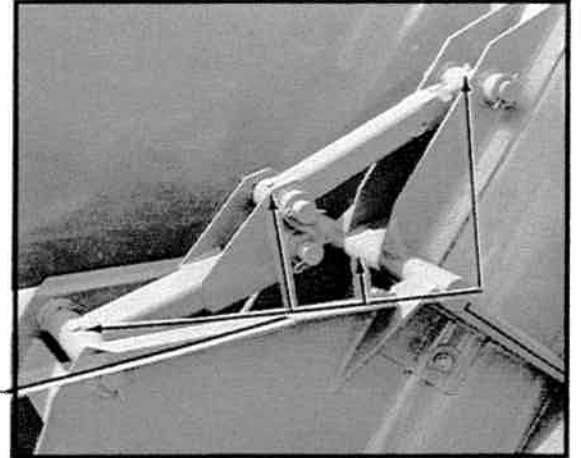

Fold Linkage and Hinge (4 Zerks)

STYLE A

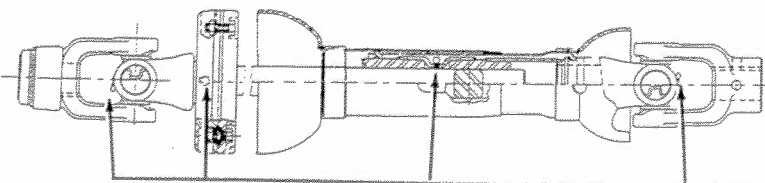

STYLE B

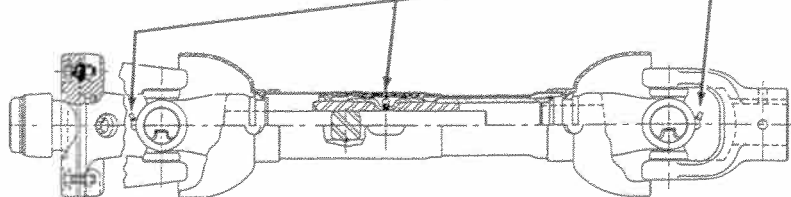

NOTE: Disconnect PTO from tractor. Retract PTO assembly and rotate shield to expose grease fitting on PTO slide.

CAUTION: Extreme operating conditions such as dirt, temperature or speed may require more frequent lubrication.

LUBRICATION

840/1040 MODELS

58619-7



Rear Bearing (Horizontal Auger)

46331-28

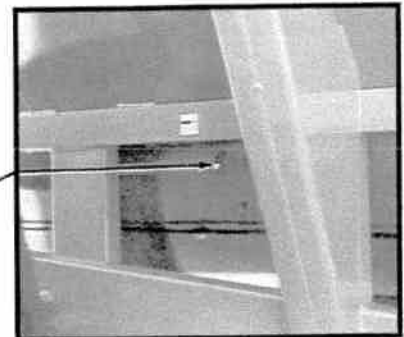

Center Bearing (Horizontal Auger)

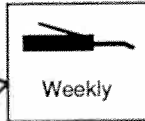

16D

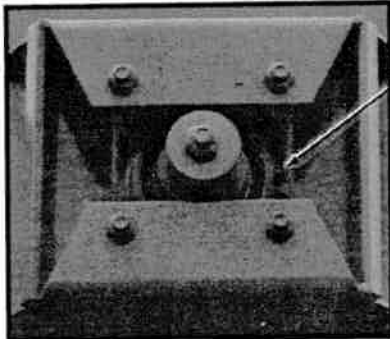

Upper Bearing (Vertical Auger)

58619-53



Lower Bearings (Vertical Auger)
Front Bearing (Horizontal Auger)

54813-62

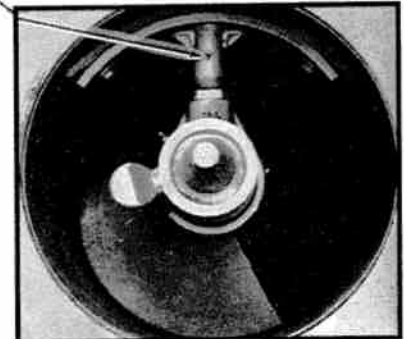

Center Bearing (Vertical Auger)

58619-23

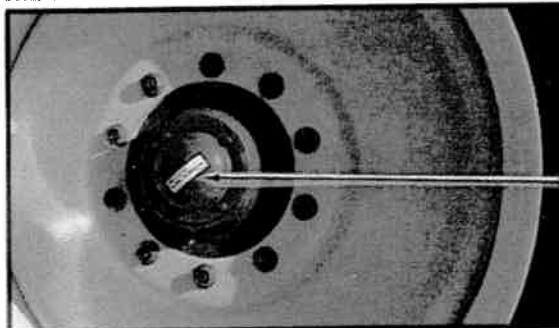

Wheel Bearings (1 Zerk Per Wheel Hub)

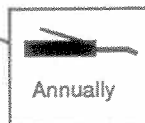

49735-14

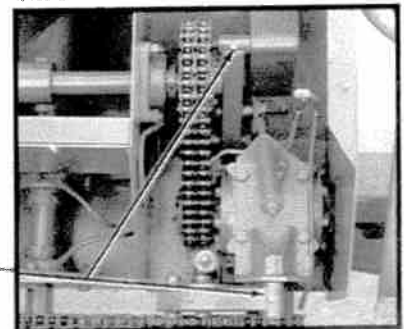

Drive Chain Idlers (Vertical and Horizontal Augers)

CAUTION: Extreme operating conditions such as dirt, temperature or speed may require more frequent lubrication.

49735-13

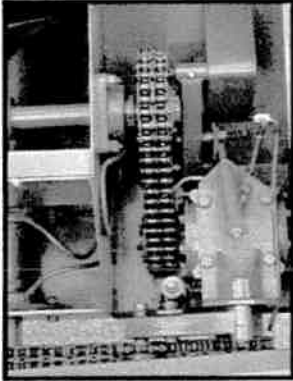

58619-56



Drive Chains

58619-12

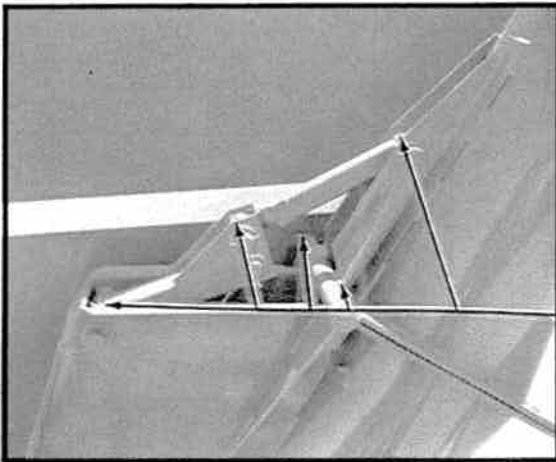

Fold Linkage and Hinge (5 Zerks)

STYLE A

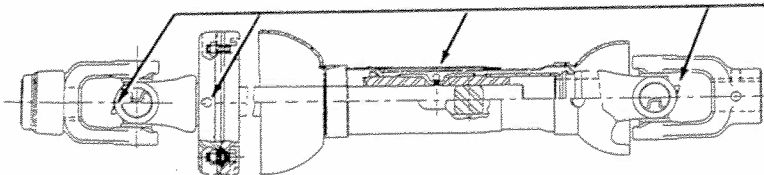

STYLE B

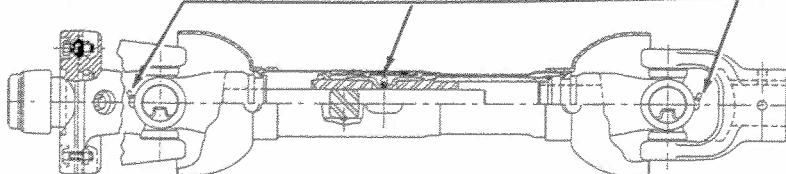

STYLE C

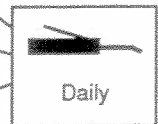
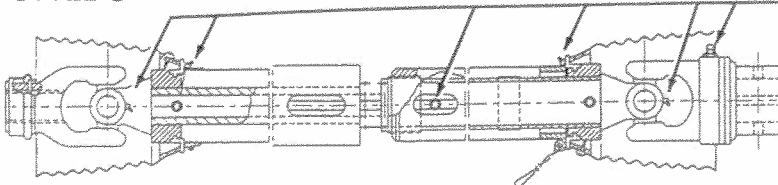

NOTE: Disconnect PTO from tractor. Retract PTO assembly and rotate shield to expose grease fitting on PTO slide.

CAUTION: Extreme operating conditions such as dirt, temperature or speed may require more frequent lubrication.

LUBRICATION

SOF-TRAK Wagon Track and Carriage

54731-7

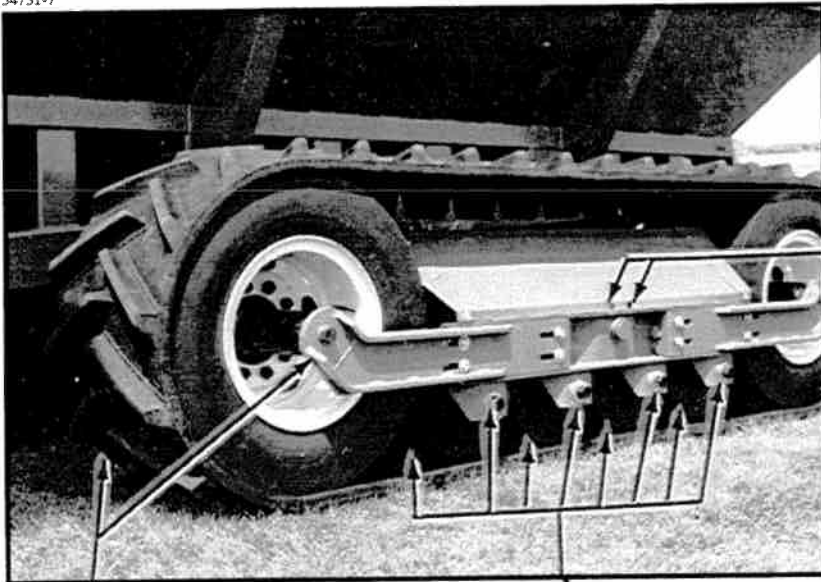

Axle
(2 Per Side)

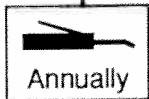

*Endwheel Spindle Bolt
(2 Per Endwheel Assembly)

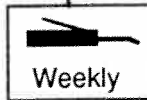

*Midwheel Spindle Bolt
(2 Per Midwheel Assembly)

* Pump grease into hub until grease comes out around the seals.

ROW CROP Wagon Axle

58619-10

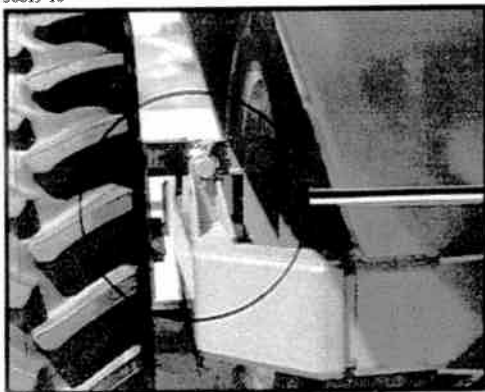

Parallel Linkage Assembly
(21 Zerks Per Side)

CAUTION: Extreme operating conditions such as dirt, temperature or speed may require more frequent lubrication.

OPERATION

The following information is general in nature and was written to aid the operator in preparing the tractor and auger wagon for use and to provide general operating procedures.

INITIAL PREPARATION OF THE WAGON

Lubricate the auger wagon per the lubrication information in this manual prior to initial operation and at prescribed intervals thereafter. Make sure all tires have been properly inflated prior to each use. Check all drive chains for proper tension and lubrication.

TRACTOR PREPARATION AND HOOKUP

1. Slide tractor drawbar in as far as possible and still allow PTO shaft to have sufficient clearance to prevent damage to drive line components when making sharp turns and operating over uneven ground.
2. Connect auger wagon to tractor hitch using a high quality hitch pin of sufficient length and secure pin with a locking device.

Recommended pin diameter:

- Single Clevis Pin recommended and supplied by the tractor manufacturer. (Max. 1 3/4")
- Double Clevis Min. 1 3/8"/Max. 1 1/2"

NOTE: The single clevis hitch can be turned over for an additional 1 1/2" hitch height adjustment. (Recommended mounting bolt torque - 380 ft. lbs.)

46331-94

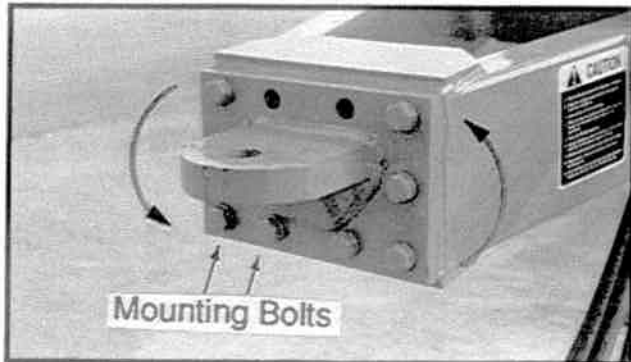

NOTE: Auxiliary attaching systems (safety chains) are available from KINZE Repair Parts. Check state and local regulations for requirements.

58780-5

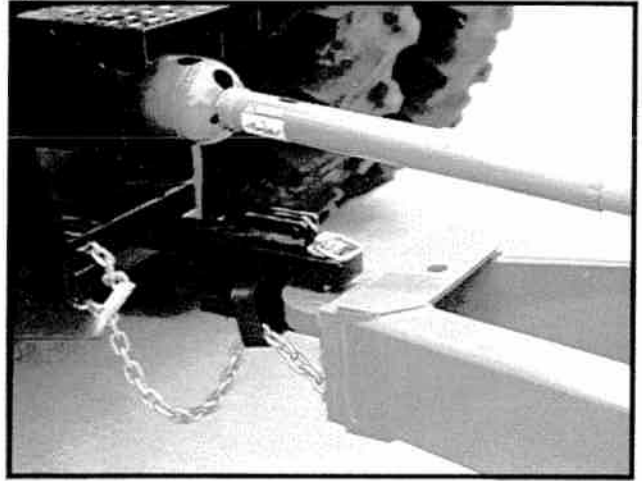

3. Attach wagon PTO connecting yoke to tractor PTO shaft. Be sure spring loaded yoke pin engages groove in tractor PTO shaft. Check that slip tube grease fitting is visible through hole of outer tube.

CAUTION: Ensure hitch height is sufficient to prevent severe bends in PTO U-joint angles.

4. Attach quick disconnect fitting to ends of hydraulic hoses to match tractor hydraulic ports. (ISO couplers standard equipment) Connect hydraulic hoses to tractor ports in a sequence which is both familiar and comfortable to the operator.

WARNING: Before applying pressure to the hydraulic system, make sure all connections are tight and hoses and fittings have not been damaged. Hydraulic fluid escaping under pressure can have sufficient force to penetrate skin, causing injury or infection.

IMPORTANT: Always wipe hose ends to remove any dirt before connecting couplers to tractor ports.

OPERATION

5. Raise parking jack to maximum height to prevent damage in uneven field conditions.

6. Connect the seven terminal breakaway connector receptacle for the light package on the wagon to the seven pin connector on the tractor. If your tractor is not equipped with the SAE Standard 7-pin connector, obtain through your local tractor supply dealer. Check to be sure clearance lights and signal lights are working.

! DANGER: Because of load capacities on bridges and roads and because the wagon is not equipped with brakes, the wagon is not intended for hauling on public roadways. It is the operator's responsibility to be aware of and follow federal, state and local regulations in this regard.

NOTE: If using an auxiliary attaching system to retain the connection between the auger wagon and tractor hitch, be sure the auxiliary attaching system is of sufficient strength and length and correctly attached. Also be aware of PTO clearance.

WAC010

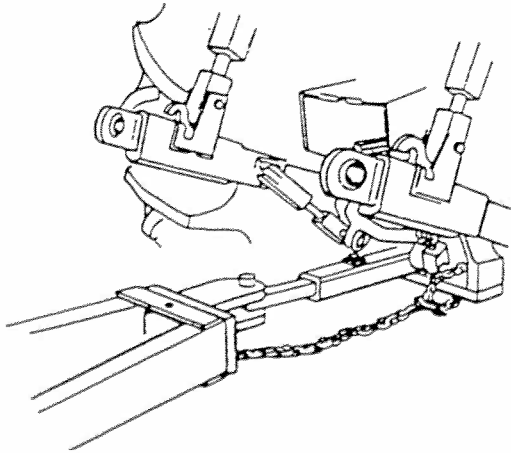

An auxiliary attaching system (safety chain) is available from KINZE Repair Parts through your Kinze Dealer.

! DANGER: Windows give only a limited view of what is behind the wagon. The use of a rear-view mirror is recommended to aid the operator in seeing behind the wagon. Always check carefully, including blind spots, before backing or turning the wagon.

UNLOADING

The unloading speed will vary with the moisture content of the grain and the PTO speed. The amount of opening on the grain flow control gate can also be used to adjust unloading speed.

1. After checking to see there are no power lines or other obstacles in the way, fold the unloading auger into the unloading position. The cylinder should be fully extended and the folding linkage locked over center to lock the augers in place. It is not necessary that the housing be bolted together. Check the speed at which the auger folds and if necessary adjust the tractor flow control. If the auger folds too fast it could damage the hinge assembly or force the spring loaded bearing at the upper end of the auger out of adjustment.

2. With clutch disengaged and tractor idling, engage PTO.

3. Open grain flow control gate. The amount of opening can be determined by the position of the control gate indicator on the front of the grain tank.

46331-50

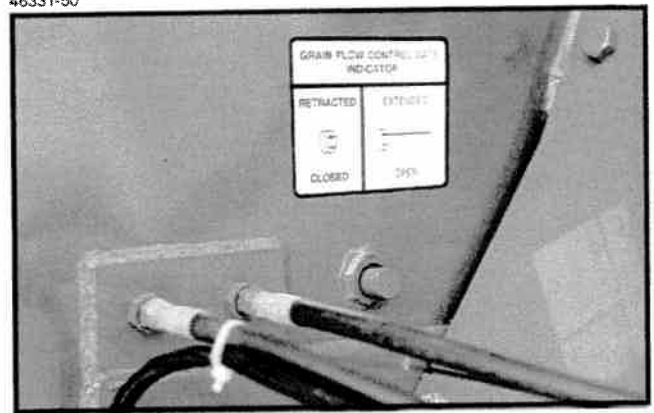

4. Increase tractor RPM to the desired speed. (Not to exceed 1000 PTO RPM.)

CAUTION: If the auger wagon is being unloaded on the move, disengage PTO before making any sharp turns.

5. As grain flow slows, reduce tractor RPM to idle.

CAUTION: Do not operate tractor PTO at full speed with the augers empty.

6. When grain flow stops, close the grain flow control gate.

7. Disengage PTO.

NOTE: If wagon is used around power lines, buildings, trees or other obstacles or if the wagon is being used in rough field conditions, the unloading auger should be folded after unloading.

! DANGER: Care must be taken when operating wagon and/or folding unloading auger around power lines.

OPERATION

CLEANOUT DOOR

⚠ DANGER: Never open cleanout door while PTO and/or augers are running.

All models are equipped with a dump door that is designed primarily for clean out purposes. However, the door can be used for pit dumping.

At the end of each season or extended use, the clean out door should be removed and the auger chamber cleaned of all debris and accumulated grain to prevent rust and mold.

Pit Dumping

If the wagon is being used strictly for pit dumping, it is important that the vertical auger drive chain be removed.

With the PTO disengaged and the tractor engine shut off, remove the clean out door. Start tractor engine and engage PTO. Regulate grain flow using grain flow control gate.

⚠ DANGER: Never work around PTO, gearbox or chains and sprockets or allow anyone else to do so while PTO is running.

58619-3

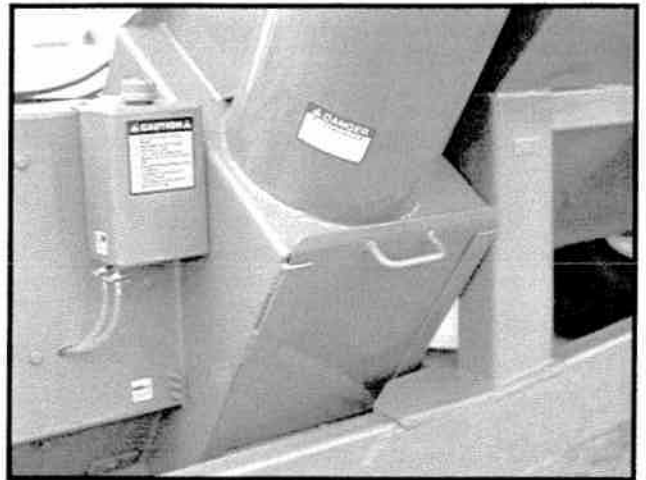

640 Model

58619-54



840/1040 Models

OPERATION

OPTIONAL ELECTRONIC SCALE

58619-34

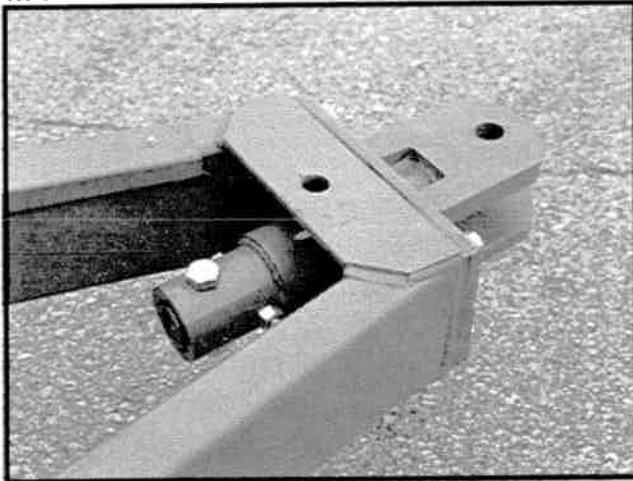

58619-30

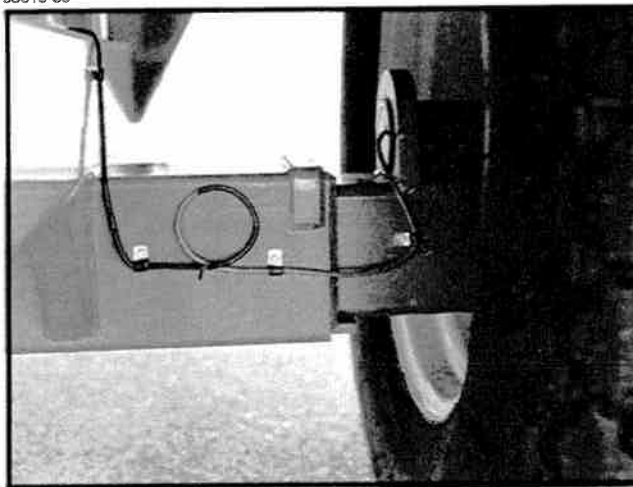

An electronic scale option is available for 640 and 840 Wheel auger wagons and 840 and 1040 Row Crop wagons (Not available for Sof-Trak models). The electronic scale option includes two weigh axles (four on Row Crop models), one hitch weigh beam, a scale indicator console for tractor mounting and the required cables, brackets and hardware for mounting.

Suggested Operation Procedures

NOTE: Movement of the wagon will cause the scale indicator reading to fluctuate.

Step 1 Press "ON" to turn scale on.

NOTE: Allow 10 to 30 minutes for the scale to warm up.

Step 2 Prior to unloading the wagon, press "TARE".

Step 3 Unload wagon. The negative reading on the scale indicator is pounds unloaded. Record weight.

Repeat Steps 2 and 3 each time the wagon is unloaded.

Consult scale manufacturer's manual provided for additional information.

MAINTENANCE

MOUNTING BOLTS AND HARDWARE

Before operating the wagon for the first time, check to be sure all nuts and bolts are tight. Check all nuts and bolts again after approximately the first 50 hours of operation and at the beginning of each season thereafter.

All bolts used on the KINZE wagon are Grade 5 (high strength) unless otherwise noted. Refer to the torque values chart when tightening bolts.

NOTE: Over tightening bolts can cause as much damage as under tightening. Tightening a bolt beyond the recommended range can reduce its shock load capacity.

TORQUE VALUES CHART - PLATED HARDWARE

Bolt Diameter	Grade 2		Grade 5		Grade 8	
	Coarse	Fine	Coarse	Fine	Coarse	Fine
1/4"	50 In. Lbs.	56 In. Lbs.	76 In. Lbs.	87 In. Lbs.	9 Ft. Lbs.	10 Ft. Lbs.
5/16"	8 Ft. Lbs.	9 Ft. Lbs.	13 Ft. Lbs.	14 Ft. Lbs.	18 Ft. Lbs.	20 Ft. Lbs.
3/8"	15 Ft. Lbs.	17 Ft. Lbs.	23 Ft. Lbs.	26 Ft. Lbs.	33 Ft. Lbs.	37 Ft. Lbs.
7/16"	25 Ft. Lbs.	27 Ft. Lbs.	37 Ft. Lbs.	41 Ft. Lbs.	52 Ft. Lbs.	58 Ft. Lbs.
1/2"	35 Ft. Lbs.	40 Ft. Lbs.	57 Ft. Lbs.	64 Ft. Lbs.	80 Ft. Lbs.	90 Ft. Lbs.
9/16"	50 Ft. Lbs.	60 Ft. Lbs.	80 Ft. Lbs.	90 Ft. Lbs.	115 Ft. Lbs.	130 Ft. Lbs.
5/8"	70 Ft. Lbs.	80 Ft. Lbs.	110 Ft. Lbs.	125 Ft. Lbs.	160 Ft. Lbs.	180 Ft. Lbs.
3/4"	130 Ft. Lbs.	145 Ft. Lbs.	200 Ft. Lbs.	220 Ft. Lbs.	280 Ft. Lbs.	315 Ft. Lbs.
7/8"	125 Ft. Lbs.	140 Ft. Lbs.	320 Ft. Lbs.	350 Ft. Lbs.	450 Ft. Lbs.	500 Ft. Lbs.
1"	190 Ft. Lbs.	205 Ft. Lbs.	480 Ft. Lbs.	530 Ft. Lbs.	675 Ft. Lbs.	750 Ft. Lbs.
1 1/8"	265 Ft. Lbs.	300 Ft. Lbs.	600 Ft. Lbs.	670 Ft. Lbs.	960 Ft. Lbs.	1075 Ft. Lbs.
1 1/4"	375 Ft. Lbs.	415 Ft. Lbs.	840 Ft. Lbs.	930 Ft. Lbs.	1360 Ft. Lbs.	1500 Ft. Lbs.
1 3/8"	490 Ft. Lbs.	560 Ft. Lbs.	1100 Ft. Lbs.	1250 Ft. Lbs.	1780 Ft. Lbs.	2030 Ft. Lbs.
1 1/2"	650 Ft. Lbs.	730 Ft. Lbs.	1450 Ft. Lbs.	1650 Ft. Lbs.	2307 Ft. Lbs.	2670 Ft. Lbs.

NOTE: Unplated bolts should be torqued approximately 1/3 higher than the above values. Bolts having lock nuts should be tightened to approximately 50% of amounts shown in chart. Bolts lubricated prior to installation should be torqued to 70% of value shown on chart.



GRADE 2
No Marks



GRADE 5
3 Marks



GRADE 8
6 Marks

MAINTENANCE

AUGER DRIVE CHAINS ADJUSTMENT

To prevent excessive wear on the auger drive chains and sprockets, the chains must be maintained and properly tensioned.

Adjust horizontal chain tension and vertical chain tension as follows:

49735-10

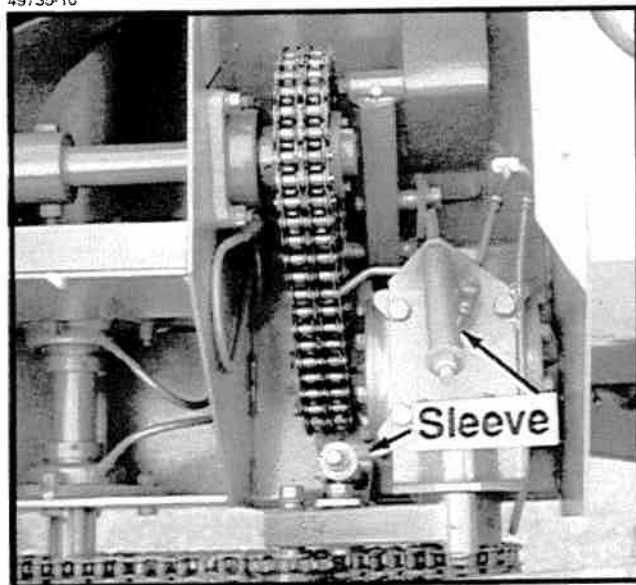

⚠ DANGER: Never run chains with inspection cover removed.

1. Tighten 5/8" lock nut until spring housing sleeve bottoms out.
2. Back off lock nut until spring housing sleeve can be rotated freely by hand.

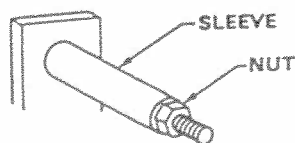

CAUTION: Chain idler spring adjustment nuts **MUST NOT BE OVER TIGHTENED**. Sleeve around spring must always turn freely by hand. After nut is tightened, if sleeve does not turn freely, loosen adjustment nut until it does.

VERTICAL AUGER FOLD

The vertical auger fold is preset at the factory and should require no additional adjustment. However, if the auger housing or cylinder is replaced, adjustment may be necessary.

When properly adjusted, the folding linkage should "snap" over-center at the end of the extended stroke of the cylinder. This over-center action holds the unloading auger in position without the need for hydraulic pressure from the cylinder.

⚠ DANGER: Stand clear when folding auger.

To adjust the folding linkage, loosen jam nut, remove pin from one end of linkage arm and rotate the arm in or out as required.

If the linkage arm is adjusted, the auger housing stop bracket (located on the grain tank and used when the auger is folded for transport) will need to be adjusted.

58619-12

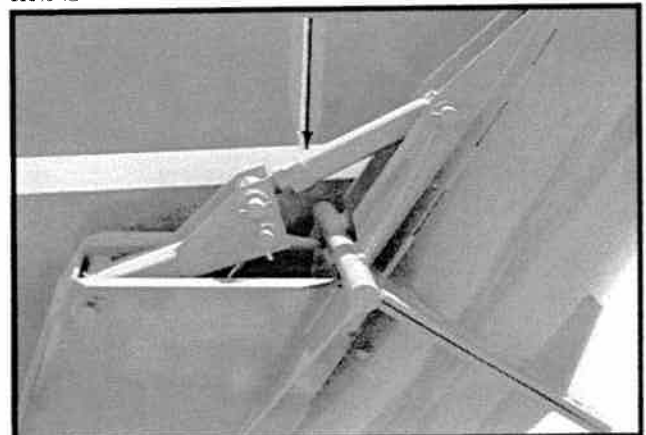

58619-58



MAINTENANCE

WIRING DIAGRAM

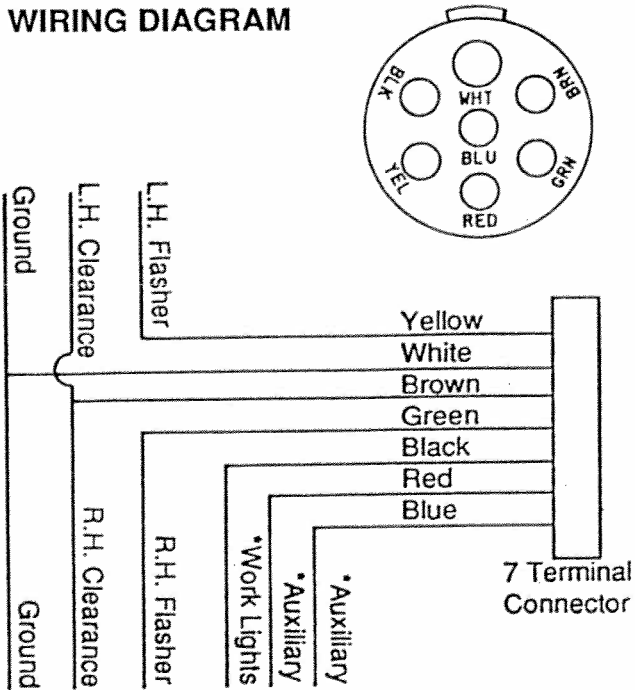

*Optional lights (to be supplied by customer) may be wired into existing auxiliary and work light wires in harness.

Light package supplied on the 40 Series grain auger wagon meets ASAE standards. For the correct wiring harness to be wired into the lights on your tractor, check with the tractor manufacturer.

69922-35

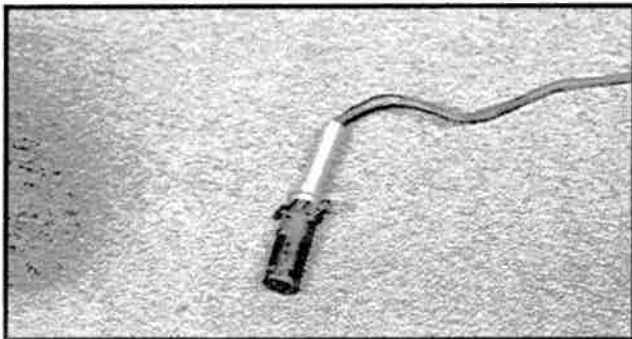

SHEAR BOLT PROTECTION

To ensure driveline and gearbox protection, all KINZE auger wagons are equipped with a shear bolt yoke in the PTO shaft. Should the auger become obstructed, the yoke is designed to shear the connecting bolt(s) before further damage can occur.

NOTE: Always use identical quantity, size and grade of bolt(s) for replacement.

46331-15

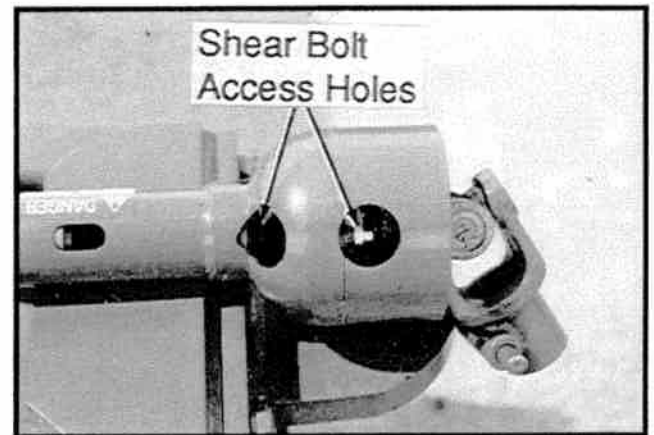

Style A PTO assembly (shown above) is equipped with access holes in the PTO shield to permit replace of the shear bolts without removal of the guard.

Style B PTO assembly (not shown) shear bolts accessible from end of PTO shield. (Similar to Style A)

71484-6

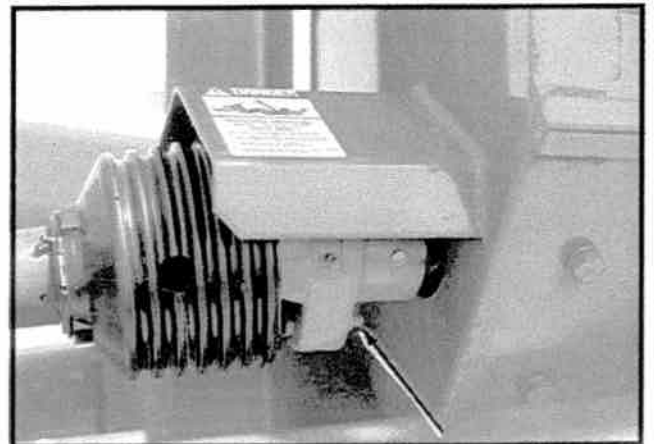

Style C PTO assembly shear bolt shown above.

MAINTENANCE

NOTE: Always use identical quantity, size and grade of bolt(s) for replacement.

640 MODEL

Style A - Shear is located in tractor half of PTO assembly. Two 5/16"-18 x 1 1/2" Grade 5 cap screws and lock nuts are used.

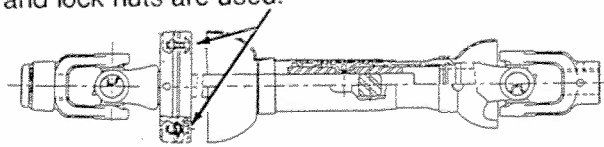

Style B - Shear is located in tractor half of PTO assembly. Two 3/8"-16 x 1" Grade 5 cap screws and lock nuts are used.

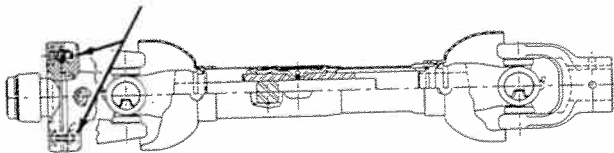

840/1040 MODELS

Style A - Shear is located in tractor half of PTO assembly. Two 5/16"-18 x 1 1/2" Grade 5 cap screws and lock nuts are used.

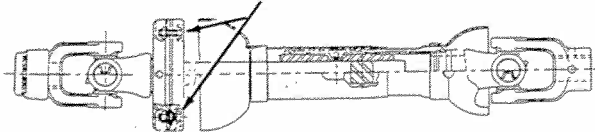

Style B - Shear is located in tractor half of PTO assembly. Two 3/8"-16 x 1" Grade 5 cap screws and lock nuts are used.

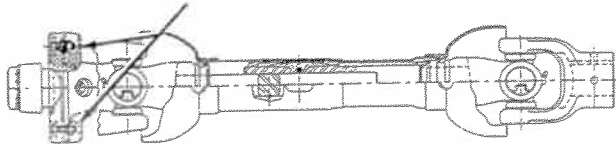

Style C - Shear is located in wagon half of PTO assembly. One 3/8"-16 x 2 1/2" Grade 5 cap screw and lock nut is used.

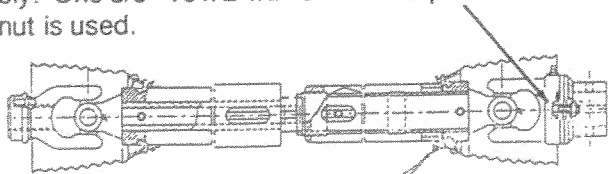

WHEEL NUTS

The wheels are attached to the hubs with press fit bolts through the hub flanges and wheel nuts. Upon any removal and installation of the wheel, clean threads with a wire brush and oil lightly to retard corrosion.

Tighten wheel nuts to 425 foot pounds torque and retorquer periodically thereafter as follows:

- a. After 4 hours use.
- b. After 16 hours use.
- c. Weekly during season.

TIRE PRESSURE

Tire pressure should be checked regularly and prior to each use of the wagon and maintained as follows:

	Minimum/Maximum
18.4 x 38; 10 Ply.....	35 PSI/40PSI
24.5 x 32; 12 Ply.....	35 PSI/40 PSI
30.5 x 32; 12 Ply	35 PSI/40 PSI
*8.25 x 20; Sof-Trak Wagon	*55 PSI

*All tire pressures must be equal.

! DANGER: Rim and tire servicing can be dangerous. Explosive separation of a tire and rim parts can cause serious injury or death.

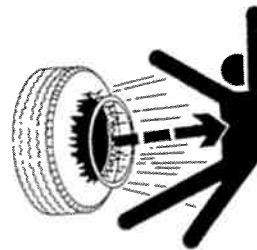

The multipiece rim used on the Sof-Trak wagon requires that specific procedures and safety instruction be followed in mounting and demounting of the tires. Do not attempt to mount a tire unless you have the proper equipment and experience to perform the job. This should only be done by persons properly trained and equipped to do the job. Always maintain the correct tire pressure. Do not inflate the tires above the recommended pressure. When inflating tires, use a clip-on air chuck and extension hose long enough to allow you to stand to one side and NOT in front of or over the tire assembly. Use a safety cage to enclose the tire and rim assembly when inflating. Inspect tires and wheels daily. Do not operate with low pressure, cuts, bubbles, damaged rims or missing wheel bolts and nuts.

MAINTENANCE

AUGER TIMING

Any time chains have been removed, check by rotating horizontal and vertical augers by hand to be sure the bolts on the front of the horizontal auger do not strike lower vertical auger flighting. (840/1040 Only)

54813-6

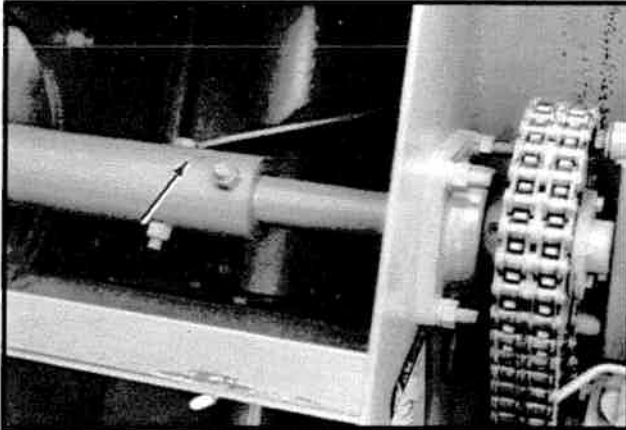

If vertical augers or bullet assembly have been removed for any reason, special care must be taken to reinstall bullet assembly in the proper position. It is possible to install the bullet assembly in two positions 180° apart. One position will place the auger assembly out of time and restrict the flow of grain between the upper and lower auger. The proper location is noted in the photo below. **A properly installed bullet assembly places the drive pin where it is closest to the flighting on the auger when measuring down the drive pin to the flighting on the auger.**

58619-39/54813-41/54813-38

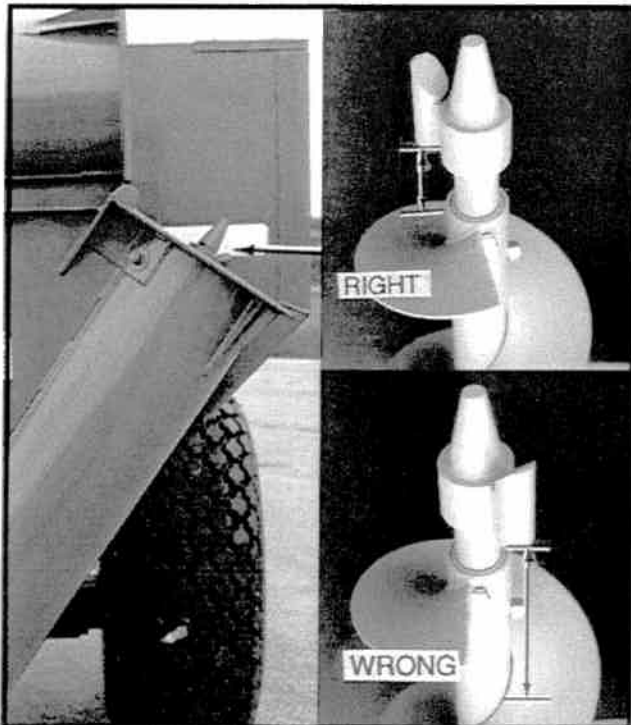

MUD SCRAPER ADJUSTMENT

(Sof-Trak Wagon)

54774-30

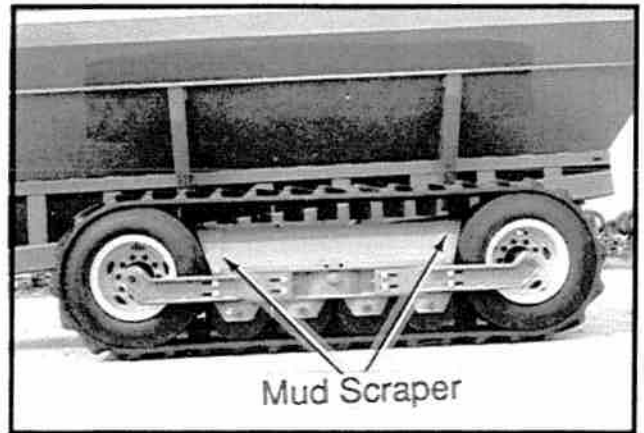

Slotted attachment holes on the scrapers allow for scraper adjustment. Each scraper should be adjusted to maintain 1/8" clearance between the scraper and tires.

TRACK TENSION (Sof-Trak Wagon)

54774-27

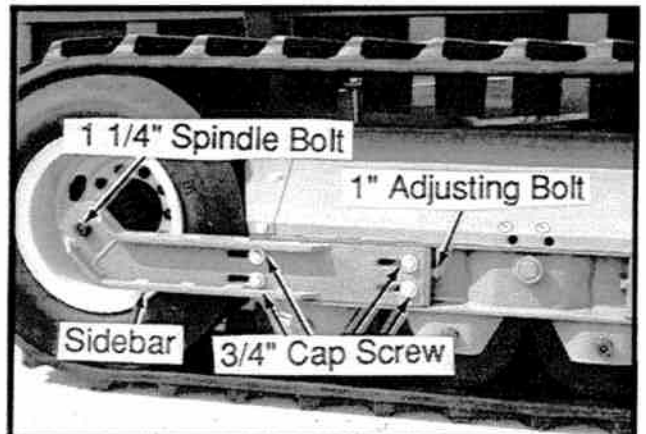

There should be approximately 1/4" to 3/8" of sag in the track at the midpoint between the front and back tires. To check for proper tension, lay a straight edge across the complete length of the track. Measure the distance between the track and the straight edge at the midpoint.

If adjustment is needed, loosen the four 3/4" attachment cap screws on the inside sidebar and the four 3/4" attachment cap screws on the outside sidebar on one end (front or rear) of the wagon. Turn the 1" adjusting bolt on the end of each sidebar in or out equal amounts according to the adjustment needed. Retighten the four 3/4" cap screws on each sidebar. Torque to 220 ft. lbs. For additional adjustment it may be necessary to repeat the above procedure on the opposite end of the track.

MAINTENANCE

TRACK ALIGNMENT (Sof-Trak Wagon)

RH490

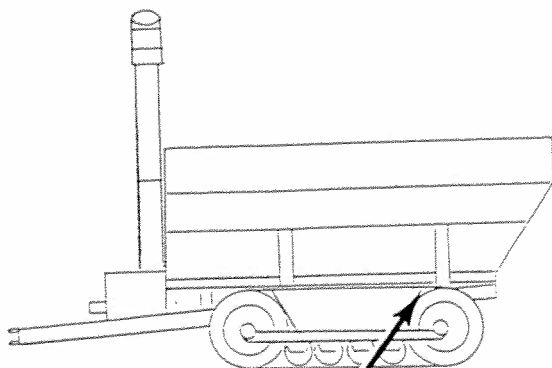

RH050390

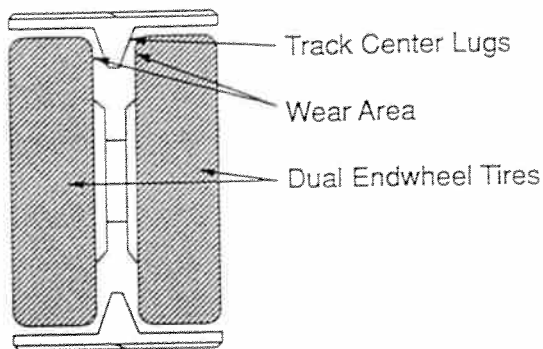

When properly aligned, the track center lugs should run centered between the dual endwheel tires as the lugs enter the tires when the tracks are rotated. Proper track alignment is important and should be **checked daily** to insure maximum life of the tires and tracks.

Misalignment will cause heat build up and scuffing of the rubber on the inside of the tires.

Equal tire pressure is important to insure proper track alignment. See "Tire Pressure".

Alignment adjustment is made by loosening the four 3/4" cap screws on each sidebar and extending or retracting the sidebar(s) until proper alignment is obtained. Extending the sidebar (Turning 1" adjusting bolt clockwise) closest to the tire showing wear or retracting (Turning the 1" adjusting bolt counterclockwise) the sidebar on the tire on the opposite side will move the lugs away from the tire. Retighten the four 3/4" cap screws on each sidebar. Torque to 220 ft. lbs.

TIRE REPAIR (Sof-Trak Wagon)

To remove a tire for repair, position a jack at the axle and raise the side of the wagon. Remove mud scraper.

Mark the position of both the inside and outside sidebars nearest the tire being removed. Loosen the four 3/4" cap screws and 1 1/4" spindle bolt on each sidebar. Loosen the 1" adjusting bolt on each sidebar. Remove the sidebar on the side next to the tire being repaired. Remove wheel nuts and remove tire.

After the tire has been reinstalled and the wheel nuts torqued to 425 ft. lbs., reinstall the sidebar. Extend sidebars to the previously marked positions and tighten all hardware. Torque 3/4" cap screws to 220 ft. lbs. and 1 1/4" spindle bolt to 1360 ft. lbs. Replace mud scraper. Check track alignment, track tension and mud scraper clearance. Adjust if necessary.

NOTE: Retorque wheel nuts as follows:

- After 4 hours use.
- After 16 hours use.
- Weekly during season.

⚠ DANGER: Rim and tire servicing can be dangerous. Explosive separation of a tire and rim parts can cause serious injury or death.

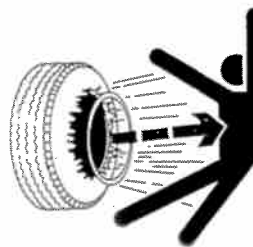

The multipiece rim used on the Sof-Trak wagon requires that specific procedures and safety instruction be followed in mounting and demounting of the tires. Do not attempt to mount a tire unless you have the proper equipment and experience to perform the job. This should only be done by persons properly trained and equipped to do the job. Always maintain the correct tire pressure. Do not inflate the tires above the recommended pressure. When inflating tires, use a clip-on air chuck and extension hose long enough to allow you to stand to one side and NOT in front of or over the tire assembly. Use a safety cage to enclose the tire and rim assembly when inflating. Inspect tires and wheels daily. Do not operate with low pressure, cuts, bubbles, damaged rims or missing wheel bolts and nuts.

MAINTENANCE

INSIDE TIRE REPAIR OR REMOVAL (Row Crop Wagon)

In order to repair or remove the inside tire on the Row Crop wagon, the complete tire/axle assembly on that side of the wagon must be removed.

IMPORTANT: If there is grain on the wagon, it must be unloaded.

Make sure the wagon is on level ground that is firm enough to support the weight of the wagon while the wagon is raised. Hitch the wagon to a tractor to stabilize the wagon fore and aft.

Remove the two 1" x 8" cap screws on the center axles. Place a hydraulic jack under the wagon frame just ahead of the tire/axle assembly and raise the wagon until weight is removed from the assembly. Place blocking under the wagon at the front axle/frame to support the wagon and lower the jack until the frame is supported by the blocking. There will be some side pressure on the wagon when the tire/axle assembly is being removed and reinstalled. Therefore, the blocking must be placed in such a way as to give a wide base of support as shown below.

59536-13



To remove the tire/axle assembly, attach a chain around the top pivot pin and using a forklift or loader, raise the tire/axle assembly slightly and slowly back up. If the assembly won't slide out, move it up and down to free it.

59536-6



IMPORTANT: Care must be taken to prevent pulling or pushing the wagon off the support blocking while removing and installing the assembly.

! **DANGER:** Never work around or under the wagon with the tire/axle assembly removed.

Remove wheel nuts and remove tire from hub.

! **DANGER:** Rim and tire servicing can be dangerous. Explosive separation of a tire and rim parts can cause serious injury or death.

After tire repair is completed, reinstall tire onto hub and torque wheel nuts to 425 ft. lbs.

NOTE: Be sure tire is reinstalled with the offset in the rim to the same side as previously installed.

Reposition tire/axle assembly under wagon at desired axle adjustment. Install the two 1" x 8" cap screws and torque to 480 ft. lbs.

NOTE: Retorque wheel nuts as follows:

- After 4 hours use.
- After 16 hours use.
- Weekly during season.

! **DANGER:** Never transport Row Crop wagon or load Row Crop wagon with grain with outer wheels removed.

MAINTENANCE

AXLE ADJUSTMENT (Row Crop Wagon)

L0112-29

The tire width on Row Crop wagons can be set for 30" row spacing or wide (36" - 38") row spacing. Row spacing is determined by axle adjustment and tire rim position.

⚠ DANGER: Never transport Row Crop wagon or load Row Crop wagon with grain with outer wheels removed.

Row Crop wagons are shipped with the outer wheel and hub assembly on each side of the wagon removed and the axle and inner wheel rims installed for 30" row spacing. For field operation with 30" row spacing, install the outer wheel assembly onto each side of the wagon with the offset in the rim to the outside as shown below. Torque wheel nuts to 425 ft. lbs.

If wide (36" - 38") row spacing is desired, remove the two 1" cap screws and complete tire/axle assembly and reverse the inner wheel so the offset in the rim is to the outside of the wagon as shown below. Follow the procedure described in "Inside Tire Repair Or Removal" for raising the wagon and removing the inside tire. Reposition tire/axle assembly approximately 12" outward from the 30" row spacing location. See illustration in next column. Torque 1" bolts to 480 ft. lbs. Install outer wheels with offset in rim to the inside. Torque wheel nuts to 425 ft. lbs. Repeat procedure on opposite side of wagon.

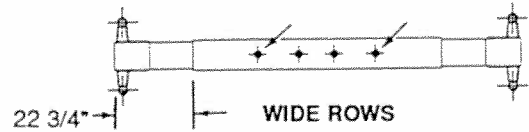
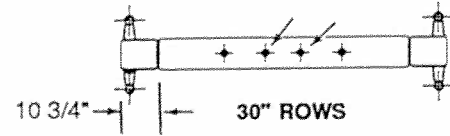

NOTE: Retorque wheel nuts as follows:

- a. After 4 hours use.
- b. After 16 hours use.
- c. Weekly during season.

RH050490

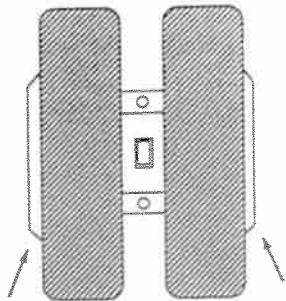

Dual wheel installation with offset in rims positioned for 30" row spacing.

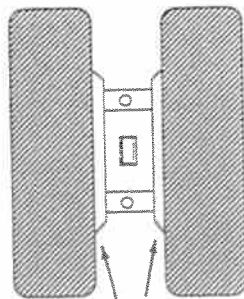

Dual wheel installation with offset in rims positioned for wide (36" - 38") row spacing.

MAINTENANCE

AXLE ADJUSTMENT (Wheel Wagon)

The wheel wagon is factory assembled with the axle in the **shipping position** and **must be extended** to the 108" or 120" operating position. Adjustment holes in the center axle allow for the axle width to be adjusted.

L0112-29

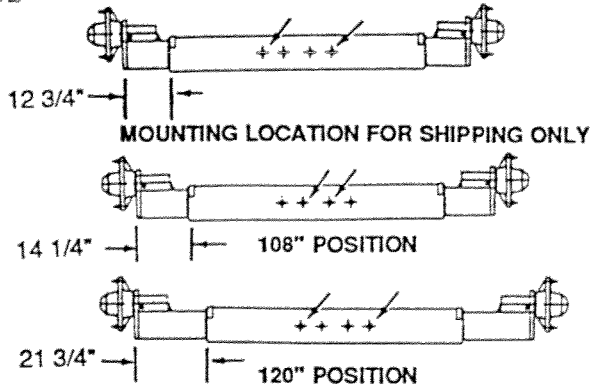

Remove the 1" x 12" cap screws on the center axle. Slide the axle stubs out approximately 1 1/2" and re-install cap screws in inner set of holes for 108" axle width. Slide axle stubs out approximately 9" and re-install cap screws in outer set of holes for 120" axle width. Torque bolts to 480 ft. lbs.

NOTE: Use of 30.5" x 32" tires on the 640 wagon requires 120" axle setting.

AXLE ADJUSTMENT (Sof-Trak Wagon)

The Sof-Trak wagon is factory assembled with the axle in the **shipping position** and **must be extended** to the 108" or 120" operating position. Adjustment holes in the center axle allow for the axle width to be adjusted.

L0112-30

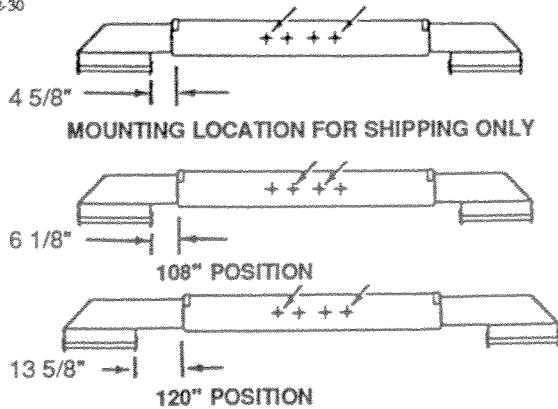

Remove the 1" x 12" cap screws on the center axle. Slide the axle stubs out approximately 1 1/2" and re-install cap screws in inner set of holes for 108" axle width. Slide axle stubs out approximately 9" and re-install cap screws in outer set of holes for 120" axle width. Torque bolts to 480 ft. lbs.

OPTIONAL ELECTRONIC SCALE

The basic elements of the electronic scale are the indicator, 3 or 5 load cells (two or four weigh axles and one hitch weigh beam), the junction box and the battery power supply.

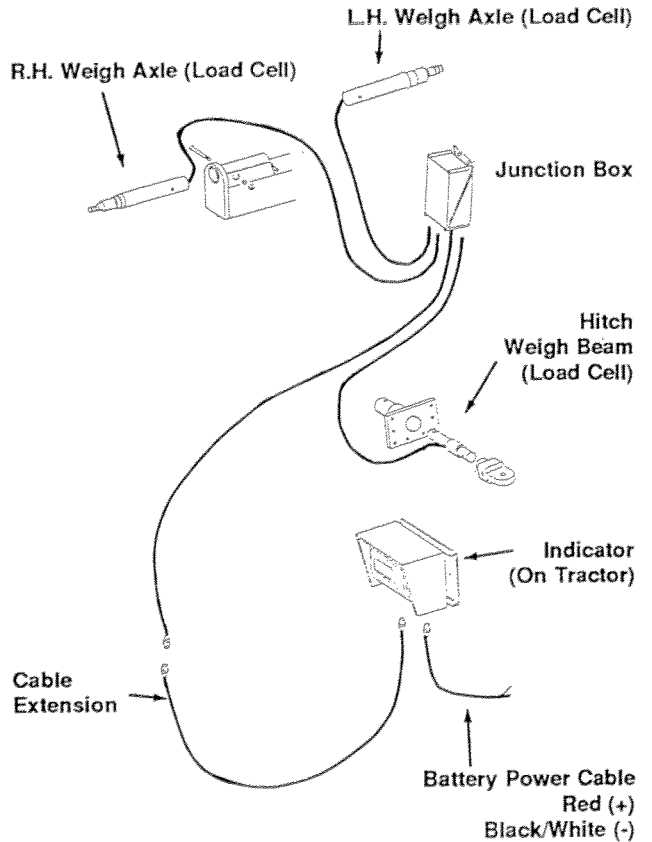

The following information includes troubleshooting charts and step by step procedures for troubleshooting problems commonly found with the electronic scale.

The only tools required are as follows:

- Multimeter (AC/DC volts and resistance)
- Small screwdriver (straight blade)
- No. 2 Phillips screwdriver

MAINTENANCE

INDICATOR FLASHES "99999"

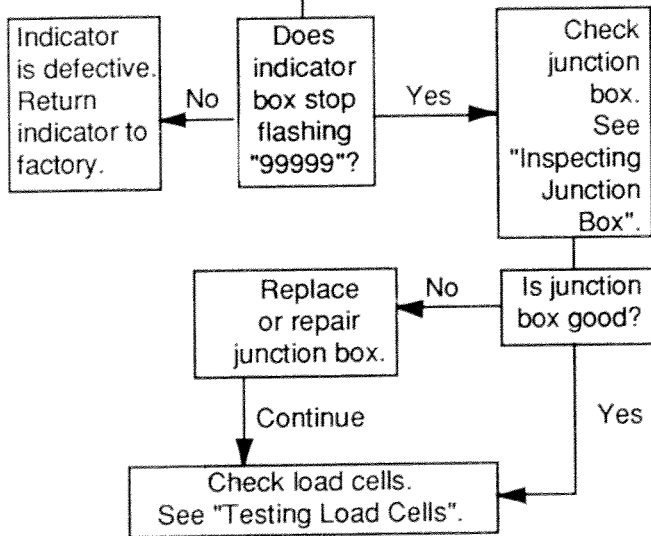
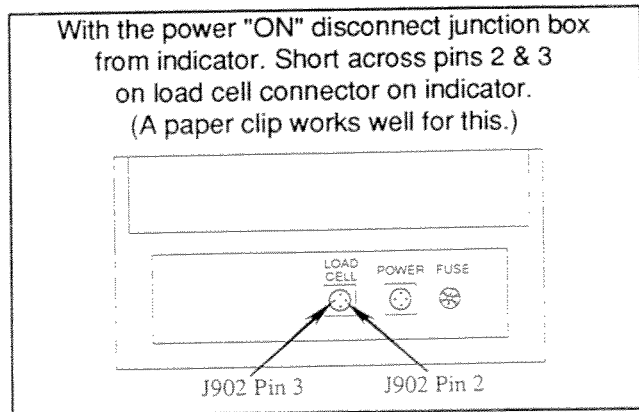

INDICATOR WILL NOT COME ON

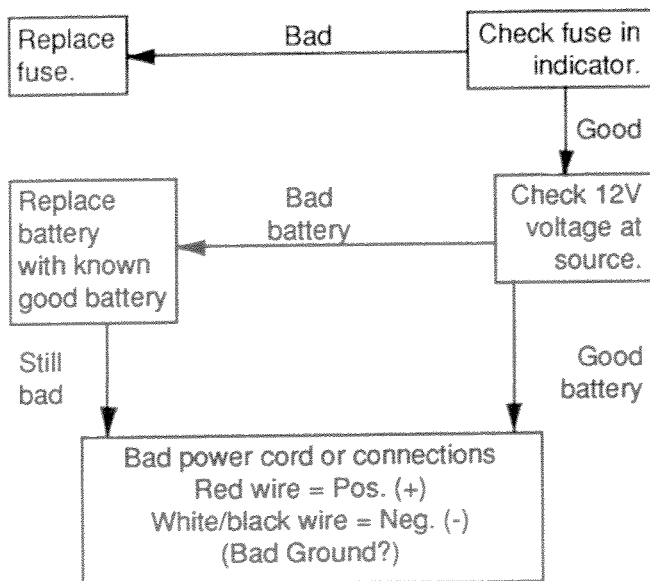

Two conditions cause the indicator not to come on. They are no power to the indicator or a bad indicator.

- No power to indicator.
 - Check for power to indicator.
 - Measure the DC output of the battery using a multimeter. The indicator requires between 10.5 and 16 volts DC.
 - Make sure battery terminals are tight.
 - Check the fuse on the power supply.
 - Make sure the RED wire is connected to the positive terminal and the BLACK/WHITE wire connected to the negative terminal on the battery.
 - Remove the power connector from the indicator and use multimeter to measure between PIN 1 (POS) and PIN 2 (NEG). The meter should read between 10.5 and 16 volts DC.
 - Check fuse.
 - Remove the fuse from the indicator to make sure it is OK. **Model 5 requires a 4 amp fuse. Model EZ150 requires an internal 2.5 amp slow blow fuse.**
- Bad indicator. If the power checks are OK, replace the indicator.

INDICATOR UNSTABLE (DRIFTS)

Variations of 50 Lbs. are normal for most scale systems with daily temperature changes. Balance indicator before use to prevent drift from causing inaccurate weight readings.

Uneven terrain causes weight shifts. Always seek smooth flat terrain to make weight readings. Wheel alignment (toe-in/toe-out) can cause weight shift when the unit moves even on smooth flat terrain.

MAINTENANCE

SYSTEM INACCURATE

Usually caused by:

- Indicator with wrong set-up. (An indicator that was set up for another scale application)
- Defective load cell.
- Load cell up-side down (new installations).

1. Determine if the inaccuracy is caused by the indicator or something else. Stand over or hang on each load cell and note each reading. If the readings are all within one display count, the indicator is causing the problem. If one or more of the readings are more than two display counts different from the the others, continue to next possibility.

2. Make sure wheels are on a level surface (not more than 6°) and there is no draw bar pull on tongue. Side pressure on a wheel or tongue can cause inaccurate readings.

3. Check for defective load cell. If you suspect you have a defective load cell, test them using the procedures in "Testing Load cells".

4. Check to be sure load cells are installed correctly. If one load cell is mounted upside down, the corner with the upside down cell will read negative. The side marked "up" on the weigh axles must be "up". The hitch weigh beam must be positioned with the black arrow on the decal "up".

INDICATOR WILL NOT BALANCE (ZERO)

Observe the display and watch for the "Zero" indicator to appear for two seconds after performing a balance to verify that the indicator has balanced.

NOTE: Zero is indicated on Model 5 when a small "bal" appears on the LCD display.

1. The indicator will not balance if the battery is low (less than 10.5 volts loaded). "LO BAT" should appear in the bottom of your display. Check the ground connections on the wagon if voltage reads above 10.5 volts and "LO BAT" is indicated on the display.

2. If battery is OK. Inspect the junction box wiring. See Step 5 in "Inspect Junction Box".

3. If the motion detection feature is turned ON and the display is unstable the indicators will not allow you to balance.

NOTE: The bell symbol "▲" on the upper side of the display will be flashing to signify the unstable condition on a Model 5 indicator. On Model EZ150 indicators, a "▲" will appear under the word "Motion".

INSPECTING THE JUNCTION BOX

Step 1. Connect the junction box to the indicator.

Step 2. Short between the white and green on any terminal block in the junction box.

Step 3. If the display continues to flash "99999" and the indicator checked out OK, the junction box is defective. Replace the junction box and continue to test load cells to assure that they have not been damaged. (See "Testing Load Cells".

Step 4. If the display stops flashing and stabilizes at a weight, the junction box is OK. Test load cells.

Step 5. Open the junction box cover and check wiring for the following:

- Wires connected to proper connection point, by color code.
- Terminal blocks are clamped onto metal lead, not insulation.
- Connections are tight.

Step 6. Check for water or condensation in the junction box. If damp, dry the entire box and printed circuit board thoroughly with a hair dryer.

NOTE: No hazardous voltages are present in the junction box.

TESTING LOAD CELLS (Using working Indicator & junction box)

Step 1. Disconnect all load cells from the junction box.

Step 2. Balance indicator. (short load cell jack pins 2 and 3 on Model 5)

Step 3. Connect one load cell to any junction box terminal. Be sure connections are tight and connected to proper locations by color code.

Step 4. Observe a **positive weight change** after each load cell is connected. Record the reading of each load cell.

Load cell is bad if it causes:

- Indicator to flash "99999"
- Indicator to display a negative weight (check for upside down load cell)
- Indicator to become unstable

Step 5. Stand over or hang on each load cell and observe increase in weight reading on the indicator (display weight will not be correct).

Step 6. Disconnect load cell and repeat steps 3 through 6 for each load cell.

Step 7. After all load cells are checked, compare the readings. If one cell is substantially different than the others, it is bad.

NOTE: Be sure to check each load cell to insure there are not two bad cells.

MAINTENANCE

ENDWHEEL/MIDWHEEL BEARING REPLACEMENT (Sof-Trak Wagon)

NOTE: Each midwheel and endwheel assembly is equipped with a grease fitting for lubrication. The below procedure is used only for bearing replacement.

1. Endwheel Procedure:

Follow the procedure described in "Tire Repair (Sof-Trak Wagon)" to raise wagon, remove mud scraper, release track tension and remove inner and outer sidebars nearest the endwheel being serviced.

Midwheel Procedure:

Follow the procedure described in "Tire Repair (Sof-Trak Wagon)" to raise wagon, remove mud scraper, release track tension, remove inner and outer sidebars and both endwheels nearest midwheel being serviced. Drop the midwheel to clear the track carriage and roll it to the closest end of the track for removal. If there is a midwheel between the endwheel and the midwheel being serviced, it must be removed also.

2. Remove double nuts and slide spindle from hub.
3. Remove bearings, seals and cups and discard. Clean and dry hub.
4. Press in new bearing cups with thickest edge facing in.
5. Pack bearings with heavy duty wheel bearing grease thoroughly forcing grease between roller cone and bearing cage. Also fill the space between the bearing cups in the hub with grease.
6. Place inner bearing in place and install seal.
7. Clean spindle and install in hub.
8. Install outer bearing, seal and stepped nut. Tighten stepped nut until there is some drag when the spindle is rotated. This assures that all bearing surfaces are in contact. Back off stepped nut 1/4 turn or until there is only slight drag when rotating the hub. Install jam nut to lock against stepped nut.

9. Endwheel Procedure:

Follow the procedure described in "Tire Repair (Sof-Trak Wagon)" to reinstall the sidebars and mud scraper. Check track alignment, track tension and mud scraper clearance after completing the procedure.

Midwheel Procedure:

Raise midwheel assembly into position under the track carriage, install inner and outer spindle bolts and torque to 1360 ft. lbs. Follow the procedure described in "Tire Repair (Sof-Trak Wagon)" to reinstall endwheel assembly, sidebars, track tension and mud scraper. Check track alignment, track tension and mud scraper clearance after completing the procedure.

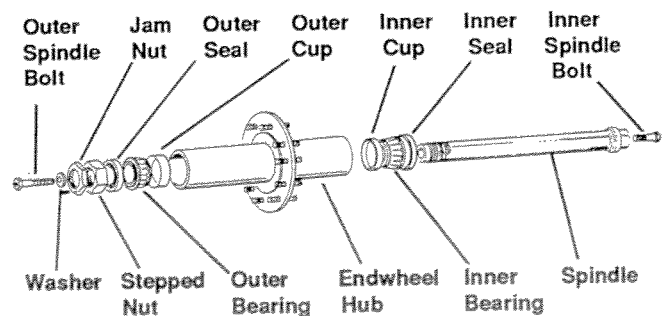
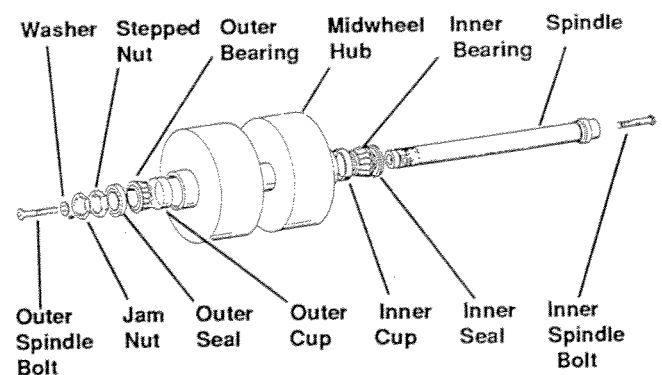

MAINTENANCE

WHEEL BEARING REPLACEMENT (Wheel/Row Crop Wagon)

1. Raise tire clear of ground and remove wheel.
2. Remove hub cap attachment hardware and remove cap from wheel hub.
3. Remove cotter pin, axle nut and 2" washer.
4. Slide hub from axle spindle, using a hub puller if necessary.
5. Remove bearings and cups from hub and discard. Thoroughly clean and dry wheel hub.
6. Press in new bearing cups with thickest edges facing in.
7. Pack bearing with heavy-duty wheel bearing grease, thoroughly forcing grease between roller cone and bearing cage. Also fill the space between the bearing cups in the hub with grease.
8. Place inner bearing in hub and press in new grease seal with lip pointing towards bearing.
9. Clean axle spindle and install hub.
10. Install outer bearing, 2" washer and slotted hex nut. Tighten slotted hex nut while rotating the hub until there is some drag. This assures that all bearing surfaces are in contact. Back off slotted nut to nearest locking slot and install cotter pin. Check for endplay in bearings.
11. Fill hub cap half full of wheel bearing grease and install on hub with attachment bolts.
12. Install wheel and remove jack. Torque wheel nuts to 425 ft. lbs.

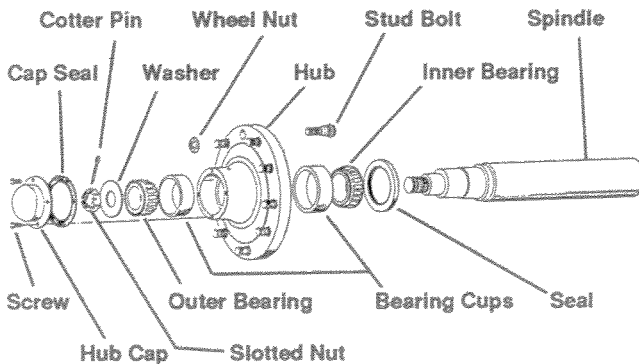

PREPARATION FOR STORAGE

- Always store the auger wagon in a dry sheltered area if possible.
- Remove all trash that may be wrapped on sprockets or shafts and remove dirt that can draw moisture.
- Remove dump door and clean out all accumulated grain and debris from auger chamber.
- Wash wagon inside and out.
- Clean all drive chains and coat with a rust preventative spray or remove chains and submerge in oil.
- Lubricate auger wagon at all lubrication points.
- If possible, remove weight from all tires, particularly if the unit is being stored outdoors.
- Repaint any areas where paint has been removed. This is particularly important in the inside of the grain tank. Rust in this area will shorten the life of the wagon as well as prevent grain from smoothly sliding to the bottom of the tank.
- Inspect the wagon for parts that are in need of replacement and order during the "off" season.
- Coat exposed surface of all cylinder piston rods with grease or rust preventative spray.



PARTS LIST INDEX

DRIVE COMPONENTS

Cylinders.....	P37/P38
Gearbox.....	P6/P7
Horizontal Auger Drive.....	P18/P21
Horizontal Augers And Bearings.....	P22/P23
PTO Assembly.....	P2/P5b
Vertical Auger - Lower Section.....	P10/P13
Vertical Auger - Upper Section.....	P8/P9
Vertical Auger Drive.....	P14/P17

MAIN FRAME

Axle.....	P30/P32
Endwheel (Sof-Trak Wagon).....	P35
Grain Flow Control Gate.....	P24/P27
Grain Tank Panels.....	P28/P29
Hitch Cap/Plate.....	P36
Hub And Tire Assembly (Wheel, Scale And Row Crop Wagons).....	P34
Jack Assembly.....	P39/P40
Midwheel (Sof-Trak Wagon).....	P35
Optional Safety Chain.....	P36
Track And Carriage (Sof-Trak Wagon).....	P33

ELECTRICAL

Electronic Scale Components.....	P41
Light Package.....	P42/P42a
Decals, Reflectors And Tie Straps.....	P43/P45
Numerical Index.....	a

PTO ASSEMBLY 1 3/8"-21 SPLINED YOKE

640

WAC008

STYLE A

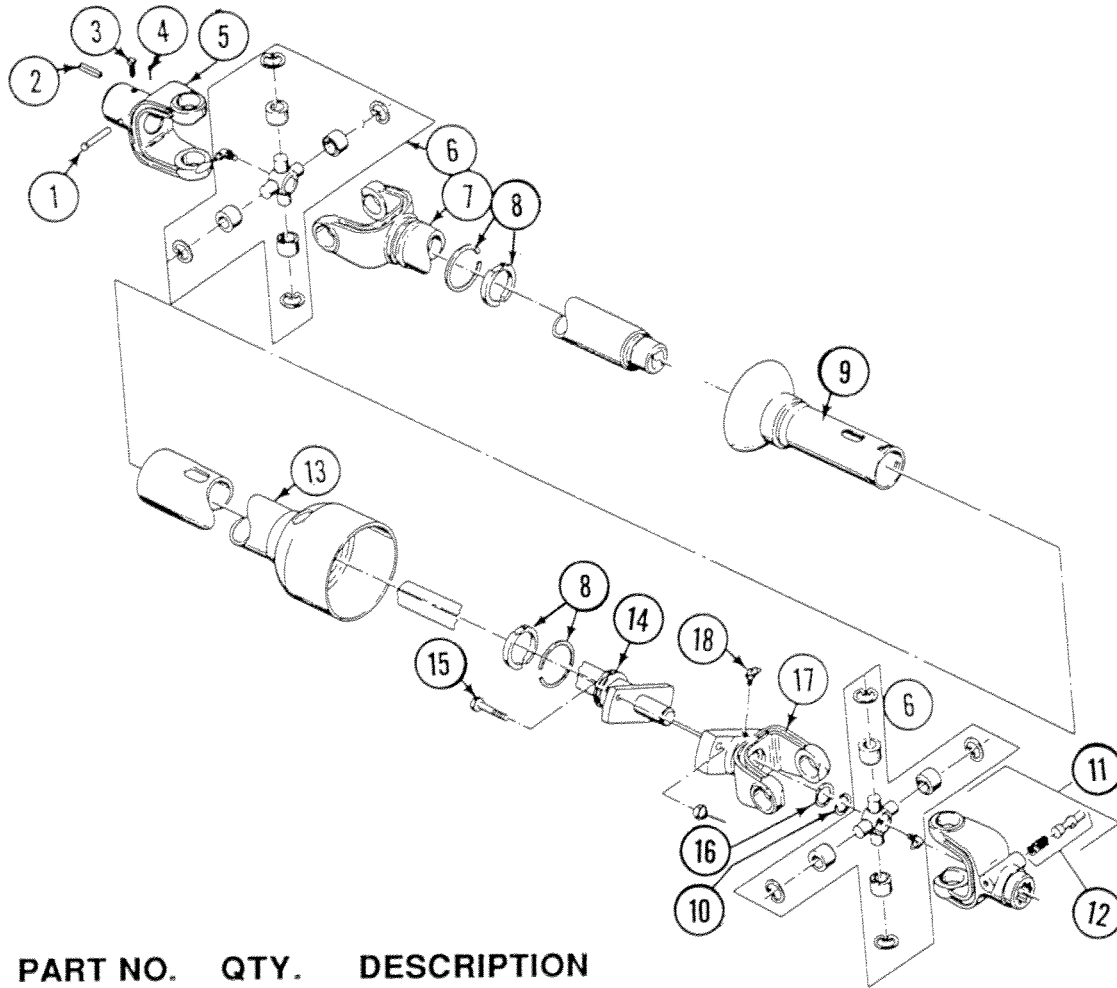

ITEM	PART NO.	QTY.	DESCRIPTION
1.	G10556	1	Clevis Pin, 3/8" x 2 1/2"
2.	GD0147	1	Key, 1/4" x 1/4" x 2"
3.	G10700	1	Set Screw, 3/8" x 1"
4.	G10456	1	Cotter Pin, 1/8" x 3/4"
5.	GR0343	1	End Yoke
6.	GR0344	2	U-Joint Repair Kit
7.	GR0345	1	Yoke and Tube
8.	GR1182	-	Nylon Repair Kit
9.	GR0347	1	Inner Guard, Includes Item 8 - Machine Half
10.	GR0252	1	Retaining Ring
11.	GR0353	1	Lock Yoke Assembly, Includes Item 12
12.	GR0354	-	"Saf-T-Pin" and Spring Kit
13.	GR0349	1	Outer Guard, Includes Item 8 - Tractor Half
14.	GR0350	1	Shaft W/Shear Flange
15.	G10133	2	Hex Head Cap Screw, 5/16"-18 x 1 1/2", Grade 5
	G10109	2	Lock Nut, 5/16"-18
16.	G10134	1	Washer
17.	GR0351	1	Shear Yoke, Includes Item 18
18.	GR0352	-	Instamatic Lube Kit
A.	GR0342	-	PTO Half - Machine (Items 5-9)
B.	GR0348	-	PTO Half - Tractor (Items 6, 8 and 10-18)

PTO ASSEMBLY 1 3/8"-21 SPLINED YOKE

640

WAC008/WAC009

STYLE B

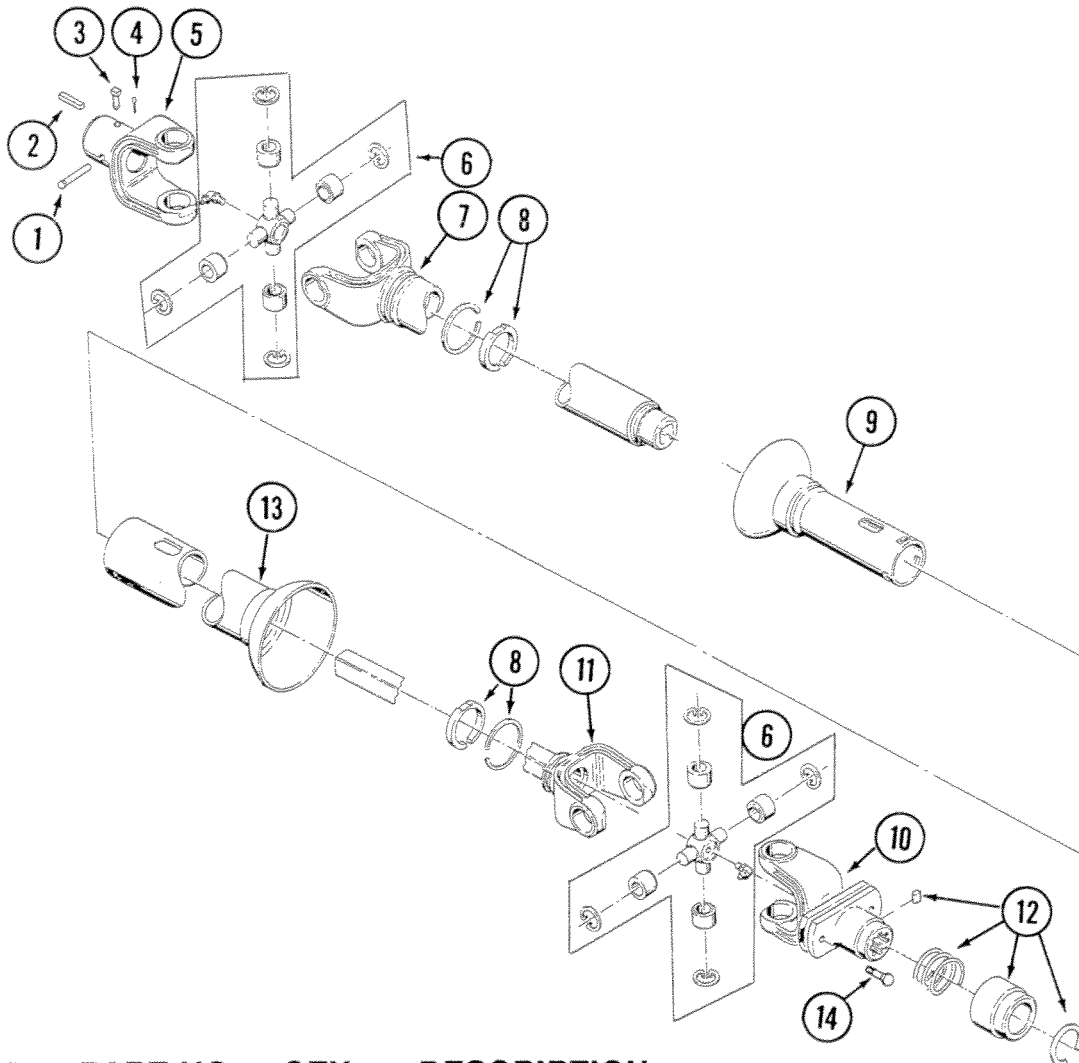

ITEM	PART NO.	QTY.	DESCRIPTION
1.	G10556	1	Clevis Pin, 3/8" x 2 1/2"
2.	GD0147	1	Key, 1/4" x 1/4" x 2"
3.	G10700	1	Set Screw, 3/8" x 1"
4.	G10456	1	Cotter Pin, 1/8" x 3/4"
5.	GR0343	1	End Yoke
6.	GR0344	2	U-Joint Repair Kit
7.	GR0345	1	Yoke and Tube
8.	GR1237	-	Nylon Repair Kit
9.	GR0347	1	Inner Guard, Includes Item 8 - Machine Half
10.	GR1236	1	Ball Shear Assembly, Includes Item 12
	GR1230	-	Ball Shear Repair Kit, Includes (31)Balls, (1)Hex Bolt, (1)Blank
11.	GR1235	1	Yoke And Shaft Assembly
12.	GR0254	-	Safety Slide Lock Repair Kit
13.	GR1234	1	Outer Guard, Includes Item 8 - Tractor Half
14.	G10001	2	Hex Head Cap Screw, 3/8"-16 x 1", Grade 5
	G10108	2	Lock Nut, 3/8"-16
A.	GR0342	-	PTO Half - Machine (Items 5-9)
B.	GR1238	-	PTO Half - Tractor (Items 6, 8 and 10-14)

PTO ASSEMBLY HEAVY DUTY 1 3/4"-20 SPLINED YOKE

640

WAC008

STYLE A

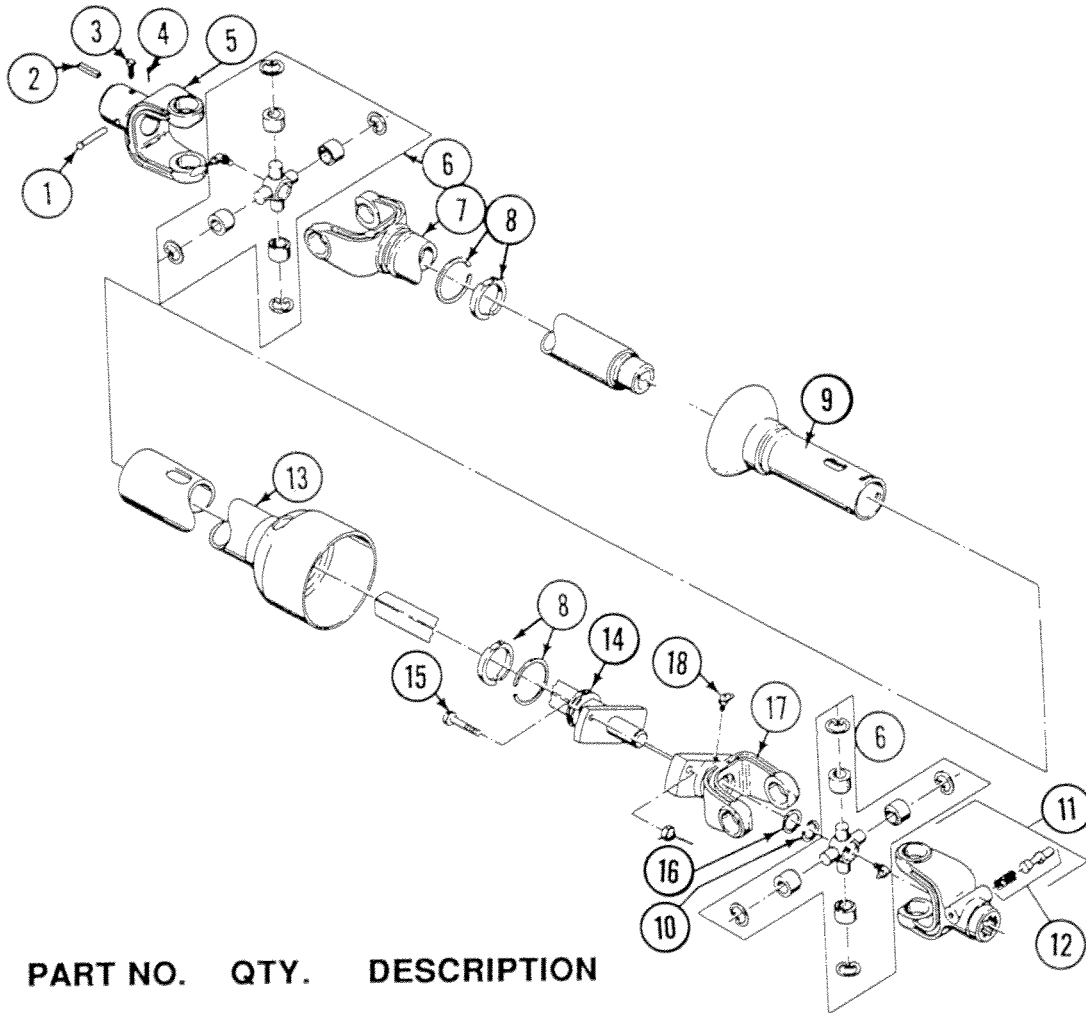

ITEM	PART NO.	QTY.	DESCRIPTION
1.	G10556	1	Clevis Pin, 3/8" x 2 1/2"
2.	GD0147	1	Key, 1/4" x 1/4" x 2"
3.	G10700	1	Set Screw, 3/8" x 1"
4.	G10456	1	Cotter Pin, 1/8" x 3/4"
5.	GR0343	1	End Yoke
6.	GR0344	2	U-Joint Repair Kit
7.	GR0345	1	Yoke and Tube
8.	GR1182	-	Nylon Repair Kit
9.	GR0347	1	Inner Guard, Includes Item 8 - Machine Half
10.	GR0252	1	Retaining Ring
11.	GR0356	1	Lock Yoke Assembly, Includes Item 12
12.	GR0900	-	"Saf-T-Pin" and Spring Kit
13.	GR0349	1	Outer Guard, Includes Item 8
14.	GR0350	1	Shaft W/Shear Flange
15.	G10133	2	Hex Head Cap Screw, 5/16"-18 x 1 1/2", Grade 5
	G10109	2	Lock Nut, 5/16"-18
16.	G10134	1	Washer
17.	GR0351	1	Shear Yoke, Includes Item 18
18.	GR0352	-	Instamatic Lube Kit
A.	GR0342	-	PTO Half - Machine (Items 5-9)
B.	GR0355	-	PTO Half - Tractor (Items 6, 8 and 10-18)

PTO ASSEMBLY HEAVY DUTY 1 3/4"-20 SPLINED YOKE

640

WAC008/WAC009

STYLE B

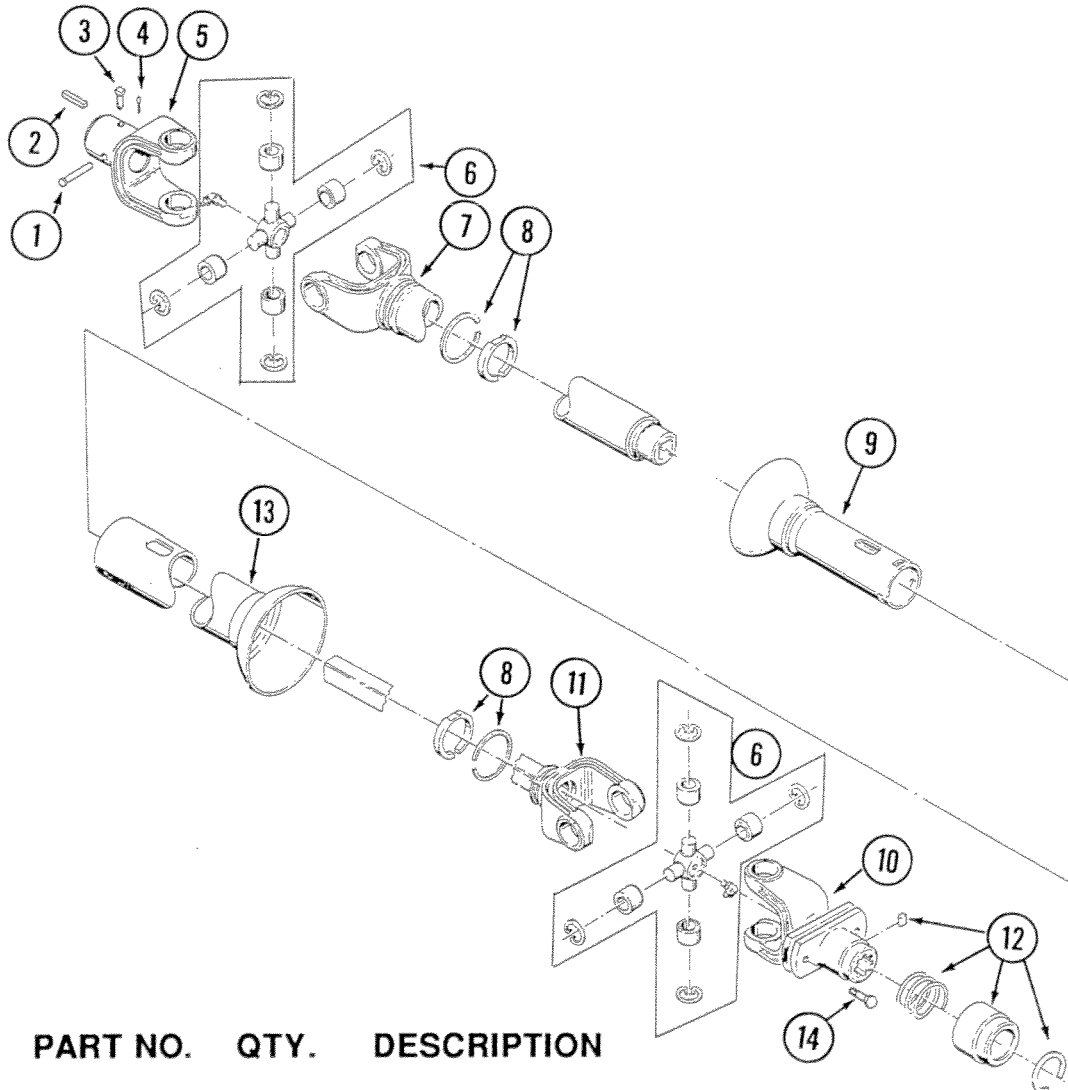

ITEM	PART NO.	QTY.	DESCRIPTION
1.	G10556	1	Clevis Pin, 3/8" x 2 1/2"
2.	GD0147	1	Key, 1/4" x 1/4" x 2"
3.	G10700	1	Set Screw, 3/8" x 1"
4.	G10456	1	Cotter Pin, 1/8" x 3/4"
5.	GR0343	1	End Yoke
6.	GR0344	2	U-Joint Repair Kit
7.	GR0345	1	Yoke and Tube
8.	GR1237	-	Nylon Repair Kit
9.	GR0347	1	Inner Guard, Includes Item 8 - Machine Half
10.	GR1239	1	Ball Shear Assembly, Includes Item 12
	GR1230	-	Ball Shear Repair Kit, Includes (31)Balls, (1)Hex Bolt, (1)Blank
11.	GR1235	1	Yoke And Shaft Assembly
12.	GR1243	-	Safety Slide Lock Repair Kit
13.	GR1234	1	Outer Guard, Includes Item 8 - Tractor Half
14.	G10001	2	Hex Head Cap Screw, 3/8"-16 x 1", Grade 5
	G10108	2	Lock Nut, 3/8"-16
A.	GR0342	-	PTO Half - Machine (Items 5-9)
B.	GR1240	-	PTO Half - Tractor (Items 6, 8 and 10-14)

PTO ASSEMBLY 1 3/8"-21 SPLINED YOKE

840/1040

WAC009

STYLE A

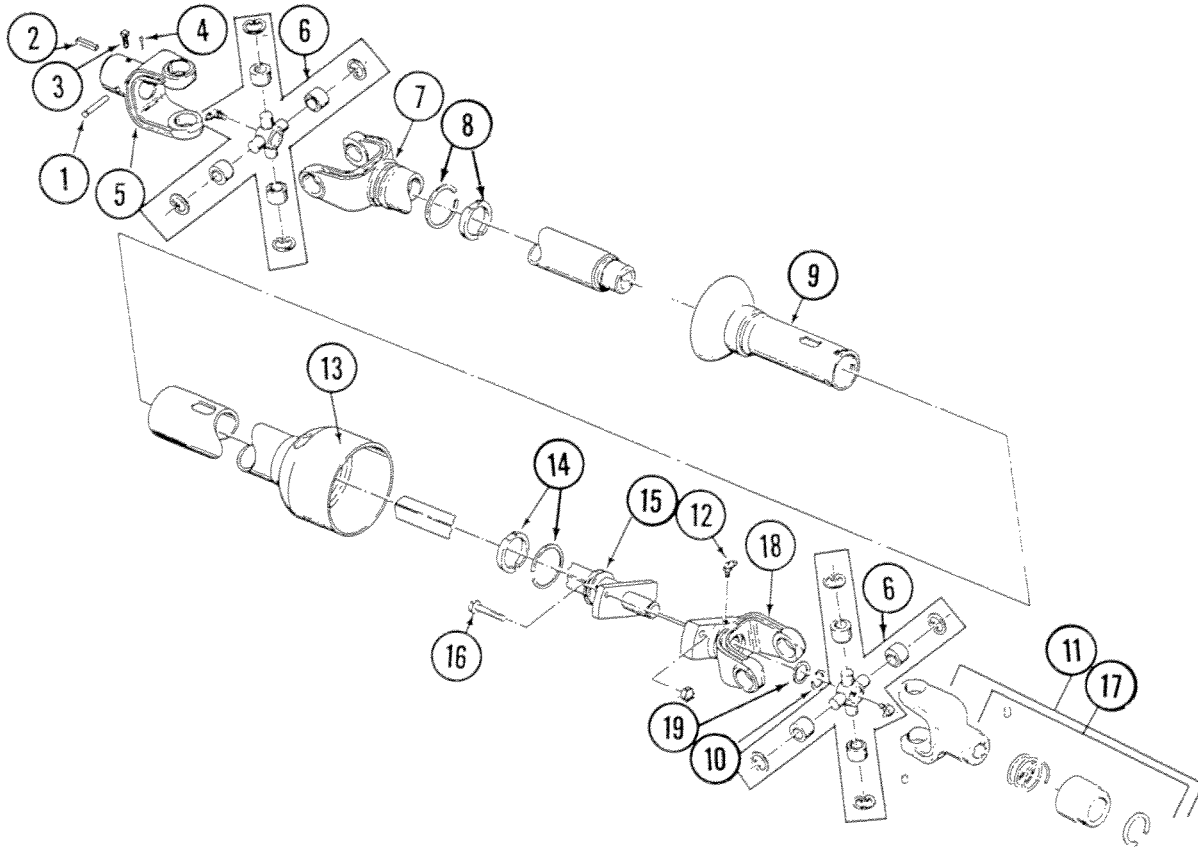

ITEM	PART NO.	QTY.	DESCRIPTION
1.	G10563	1	Clevis Pin, 3/8" x 3 1/4"
2.	GD0144	1	Key, 3/8" x 3/8" x 2 1/2"
3.	G10700	1	Set Screw, 3/8" x 1"
4.	G10456	1	Cotter Pin, 1/8" x 3/4"
5.	GR0239	1	End Yoke
6.	GR0241	2	U-Joint Repair Kit
7.	GR0242	1	Yoke and Tube
8.	GR1181	-	Nylon Repair Kit
9.	GR0238	1	Inner Guard, Includes Items 8 - Machine Half
10.	GR0252	1	Retaining Ring
11.	GR0253	1	Lock Yoke Assembly, Includes Item 17
12.	GR0251	-	Instamatic Lube Kit
13.	GR0237	1	Outer Guard, Includes Item 14 - Tractor Half
14.	GR1182	-	Nylon Repair Kit
15.	GR0248	1	Shaft W/Shear Flange
16.	G10133	2	Hex Head Cap Screw, 5/16"-18 x 1 1/2", Grade 5
	G10109	2	Lock Nut, 5/16"-18
17.	GR0254	-	Safety Slide Lock Repair Kit
18.	GR0249	1	Shear Yoke, Includes Item 12
19.	G10134	1	Washer
A.	GR0240	-	PTO Half - Machine (Items 5-9)
B.	GR0245	-	PTO Half - Tractor (Items 10-19)

PTO ASSEMBLY 1 3/8"-21 SPLINED YOKE

840/1040

WAC008/WAC009

STYLE B

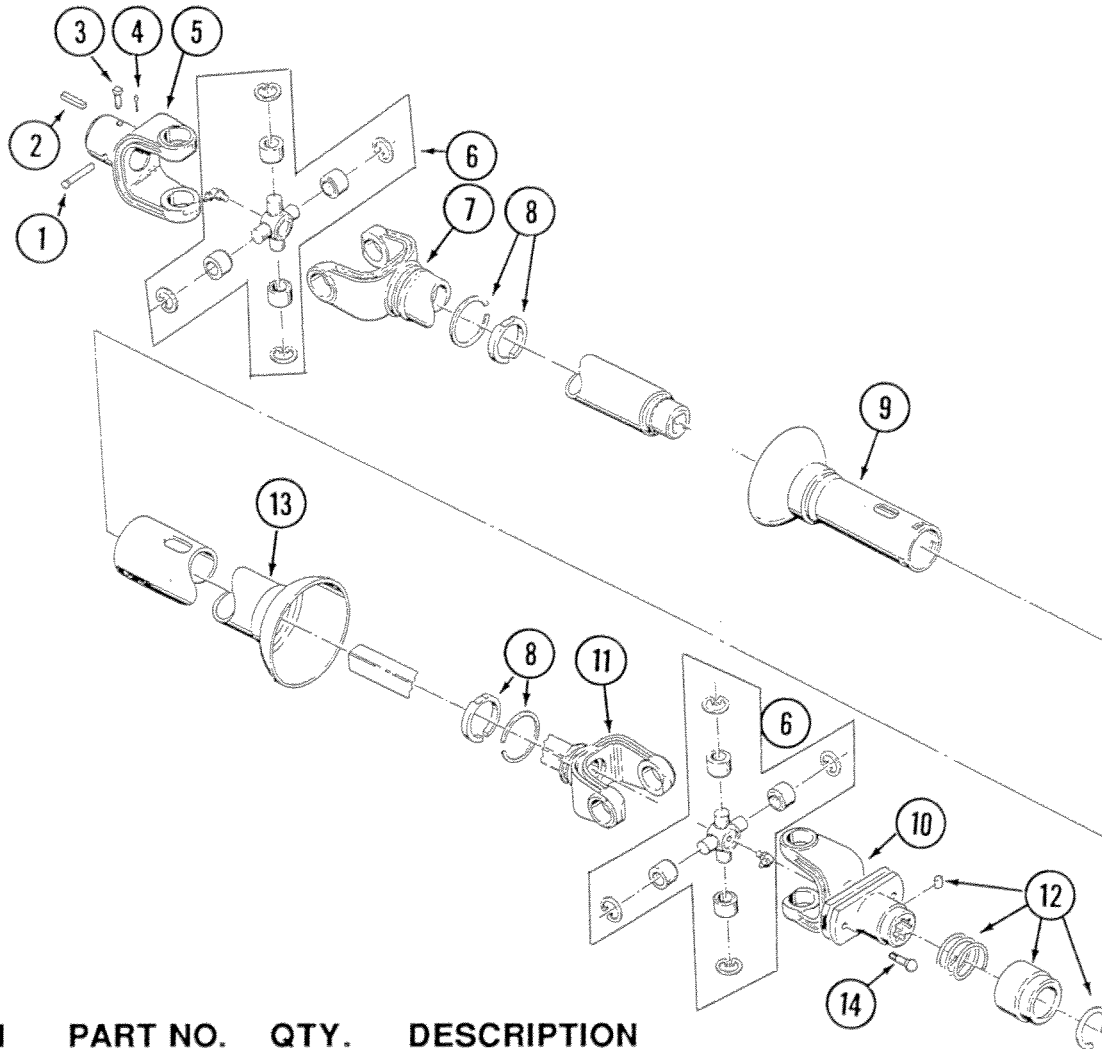

ITEM	PART NO.	QTY.	DESCRIPTION
1.	G10563	1	Clevis Pin, 3/8" x 3 1/4"
2.	GD0144	1	Key, 3/8" x 3/8" x 2 1/2"
3.	G10700	1	Set Screw, 3/8" x 1"
4.	G10456	1	Cotter Pin, 1/8" x 3/4"
5.	GR0239	1	End Yoke
6.	GR0241	2	U-Joint Repair Kit
7.	GR0242	1	Yoke and Tube
8.	GR1231	-	Nylon Repair Kit
9.	GR0238	1	Inner Guard, Includes Items 8 - Machine Half
10.	GR1227	1	Ball Shear Assembly , Includes Item 12
	GR1230	-	Ball Shear Repair Kit, Includes (31)Balls, (1)Hex Bolt, (1)Blank
11.	GR1228	1	Yoke And Shaft Assembly
12.	GR0254	-	Safety Slide Lock Repair Kit
13.	GR1247	1	Outer Guard, Includes Item 8 - Tractor Half
14.	G10001	2	Hex Head Cap Screw, 3/8"-16 x 1", Grade 5
	G10108	2	Lock Nut, 3/8"-16
A.	GR0240	-	PTO Half - Machine (Items 5-9)
B.	GR1229	-	PTO Half - Tractor (Items 10-14)

PTO ASSEMBLY 1 3/8"-21 SPLINED YOKE

840/1040

WAC009

STYLE C

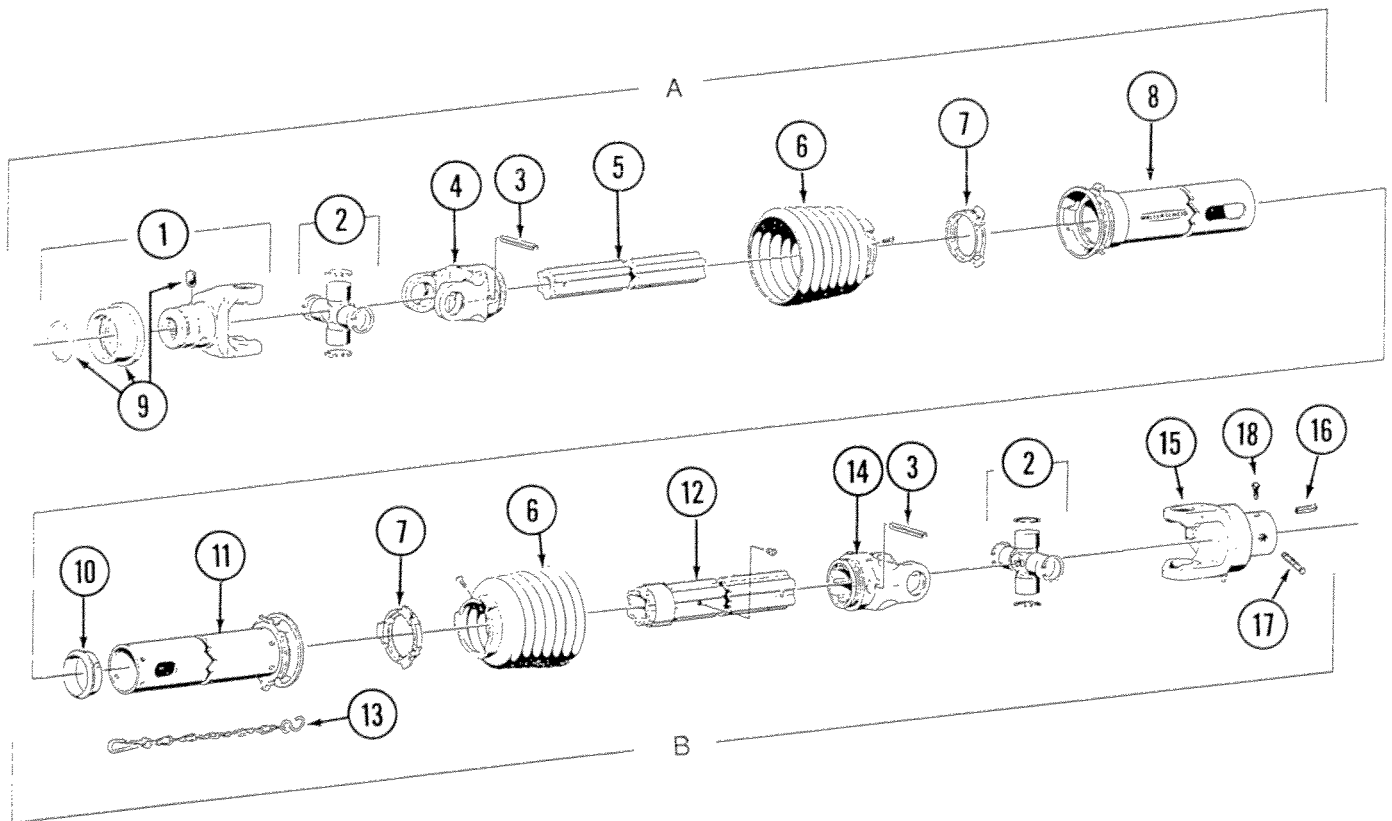

ITEM	PART NO.	QTY.	DESCRIPTION
1.	GR1209	1	Yoke, Includes Item 9
2.	GR1210	2	Cross And Bearing Kit
3.	GR1211	2	Spring Pin
4.	GR1212	1	Inboard Yoke
5.	GR1213	1	Inner Profile
6.	GR1217	2	Shield Cone W/Screw
7.	GR1220	2	Bearing Ring
8.	GR1218	1	Outer Shield Tube
9.	GR1245	-	Quick Disconnect Kit
10.	GR1222	1	Support Bearing
11.	GR1219	1	Inner Shield Tube
12.	GR1214	1	Profile And Sleeve W/Grease Fitting
13.	GR1221	1	Safety Chain
14.	GR1215	1	Inboard Yoke
15.	GR1216	1	Clutch W/Shear Bolt And Nut
	G10049	-	Hex Head Cap Screw, 3/8"-16 x 2 1/2", Grade 5
	G10108	-	Lock Nut, 3/8"-16
16.	GD0144	1	Key, 3/8" x 3/8" X 2 1/2"
17.	G10326	1	Hex Head Cap Screw, 3/8"-16 x 3 3/4"
	G10108	1	Lock Nut, 3/8"-16
18.	G10700	1	Set Screw, 3/8" x 1"
A.	GR1225	-	PTO Half - Tractor (Items 1-9)
B.	GR1224	-	PTO Half - Machine (Items 2, 3, 6, 7 And 10-15)

PTO ASSEMBLY HEAVY DUTY 1 3/4"-20 SPLINED YOKE

840/1040

WAC008

STYLE A

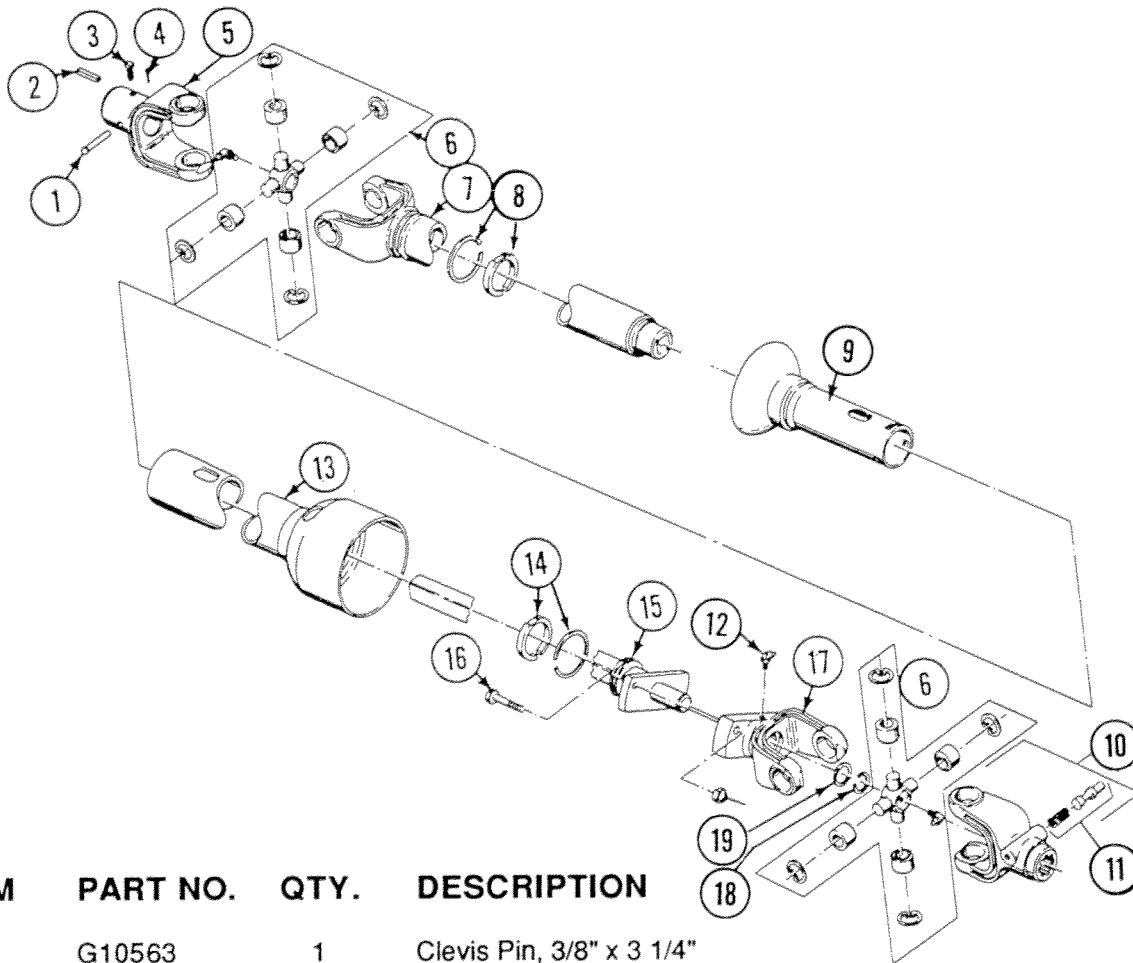

ITEM	PART NO.	QTY.	DESCRIPTION
1.	G10563	1	Clevis Pin, 3/8" x 3 1/4"
2.	GD0144	1	Key, 3/8" x 3/8" x 2 1/2"
3.	G10700	1	Set Screw, 3/8" x 1"
4.	G10456	1	Cotter Pin, 1/8" x 3/4"
5.	GR0239	1	End Yoke
6.	GR0241	2	U-Joint Repair Kit
7.	GR0242	1	Yoke and Tube
8.	GR1181	-	Nylon Repair Kit
9.	GR0238	1	Inner Guard, Includes Item 8 - Machine Half
10.	GR0289	1	Lock Yoke Assembly, Includes Item 11
11.	GR0290	-	"Saf-T-Pin" and Spring Kit
12.	GR0251	-	Instamatic Lube Kit
13.	GR0237	1	Outer Guard, Includes Item 14 - Tractor Half
14.	GR1182	-	Nylon Repair Kit
15.	GR0248	1	Shaft W/Shear Flange
16.	G10133	2	Hex Head Cap Screw, 5/16"-18 x 1 1/2", Grade 5
	G10109	2	Lock Nut, 5/16"-18
17.	GR0249	1	Shear Yoke, Includes Item 12
18.	GR0252	1	Retaining Ring
19.	G10134	1	Washer
A.	GR0240	-	PTO Half - Machine (Items 5-9)
B.	GR0250	-	PTO Half - Tractor (Items 6 and 10-19)

PTO ASSEMBLY HEAVY DUTY 1 3/4"-20 SPLINED YOKE

840/1040

WAC008/WAC009

STYLE B

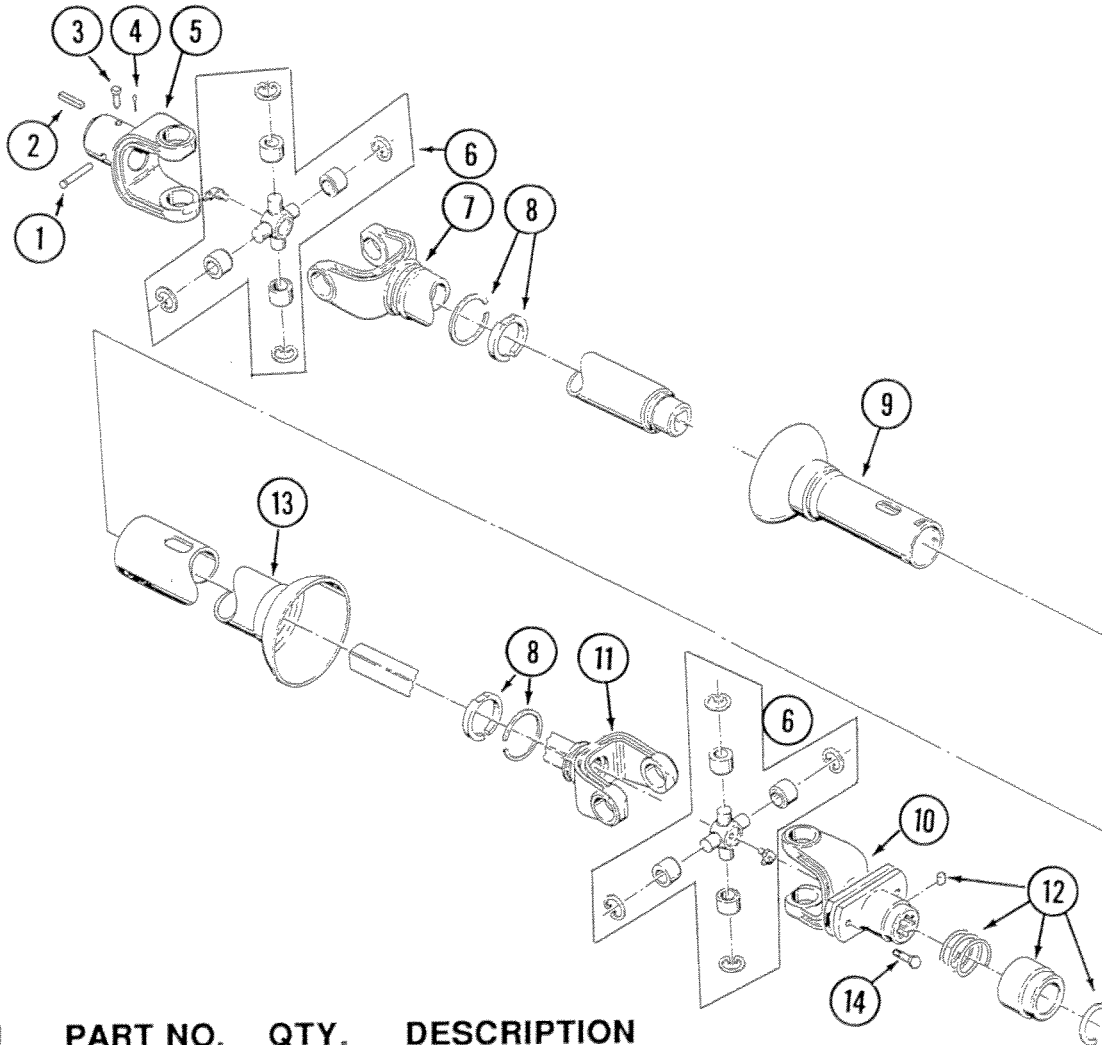

ITEM	PART NO.	QTY.	DESCRIPTION
1.	G10563	1	Clevis Pin, 3/8" x 3 1/4"
2.	GD0144	1	Key, 3/8" x 3/8" x 2 1/2"
3.	G10700	1	Set Screw, 3/8" x 1"
4.	G10456	1	Cotter Pin, 1/8" x 3/4"
5.	GR0239	1	End Yoke
6.	GR0241	2	U-Joint Repair Kit
7.	GR0242	1	Yoke and Tube
8.	GR1231	-	Nylon Repair Kit
9.	GR0238	1	Inner Guard, Includes Item 8 - Machine Half
10.	GR1233	1	Ball Shear Assembly , Includes Item 12
	GR1230	-	Ball Shear Repair Kit, Includes (31)Balls, (1)Hex Bolt, (1)Blank
11.	GR1228	1	Yoke And Shaft Assembly
12.	GR1243	-	Safety Slide Lock Repair Kit
13.	GR1247	1	Outer Guard, Includes Item 8 - Tractor Half
14.	G10001	2	Hex Head Cap Screw, 3/8"-16 x 1", Grade 5
	G10108	2	Lock Nut, 3/8"-16
A.	GR0240	-	PTO Half - Machine (Items 5-9)
B.	GR1232	-	PTO Half - Tractor (Items 8 and 10-14)

PTO ASSEMBLY HEAVY DUTY 1 3/4"-20 SPLINED YOKE

840/1040

WAC008

STYLE C

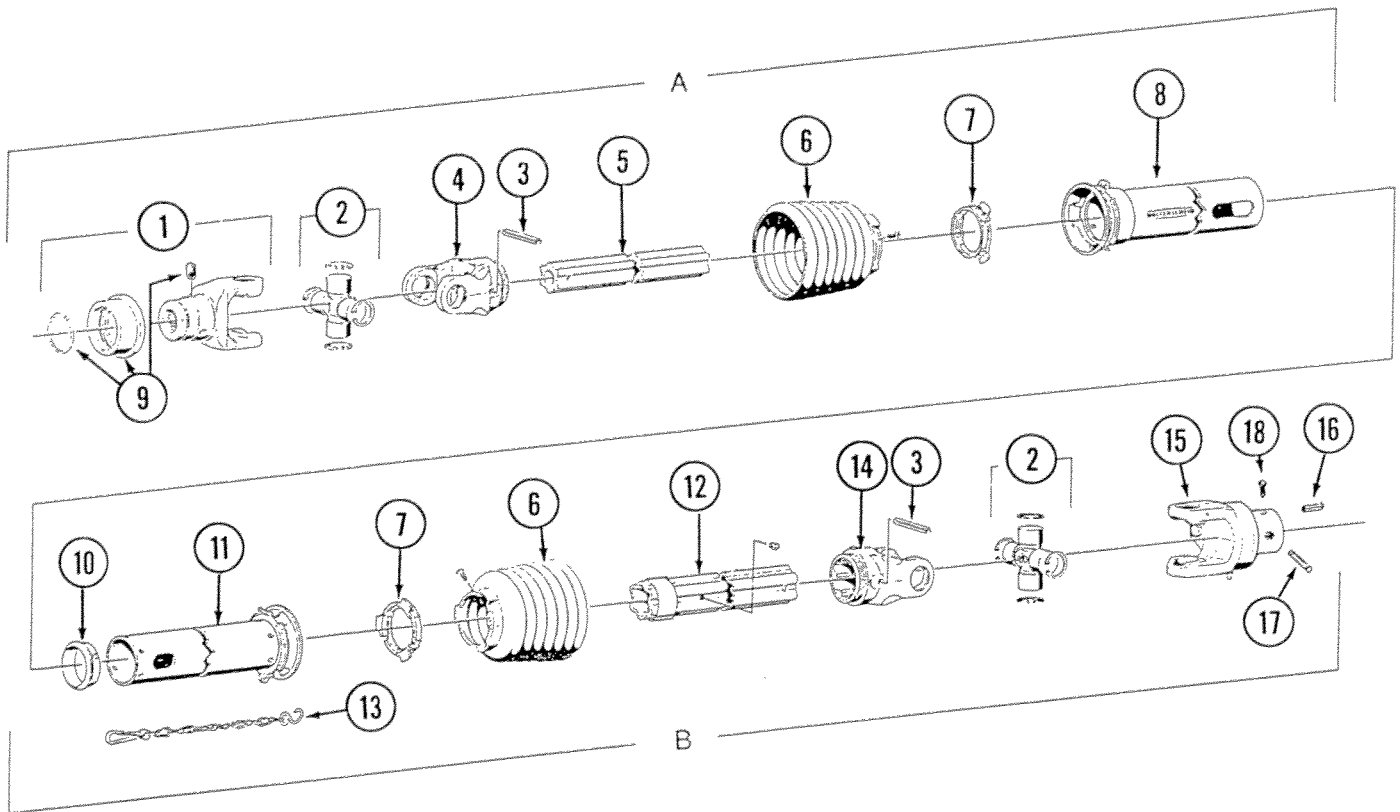

ITEM	PART NO.	QTY.	DESCRIPTION
1.	GR1223	1	Yoke, Includes Item 9
2.	GR1210	2	Cross And Bearing Kit
3.	GR1211	2	Spring Pin
4.	GR1212	1	Inboard Yoke
5.	GR1213	1	Inner Profile
6.	GR1217	2	Shield Cone W/Screw
7.	GR1220	2	Bearing Ring
8.	GR1218	1	Outer Shield Tube
9.	GR1246	-	Quick Disconnect Kit
10.	GR1222	1	Support Bearing
11.	GR1219	1	Inner Shield Tube
12.	GR1214	1	Profile And Sleeve W/Grease Fitting
13.	GR1221	1	Safety Chain
14.	GR1215	1	Inboard Yoke
15.	GR1216	1	Clutch W/Shear Bolt And Nut
	G10049	-	Hex Head Cap Screw, 3/8"-16 x 2 1/2", Grade 5
	G10108	-	Lock Nut, 3/8"-16
16.	GD0144	1	Key, 3/8" x 3/8" X 2 1/2"
17.	G10326	1	Hex Head Cap Screw, 3/8"-16 x 3 3/4"
	G10108	1	Lock Nut, 3/8"-16
18.	G10700	1	Set Screw, 3/8" x 1"
A.	GR1226	-	PTO Half - Tractor (Items 1-9)
B.	GR1224	-	PTO Half - Machine (Items 2, 3, 6, 7 And 10-15)

GBX002

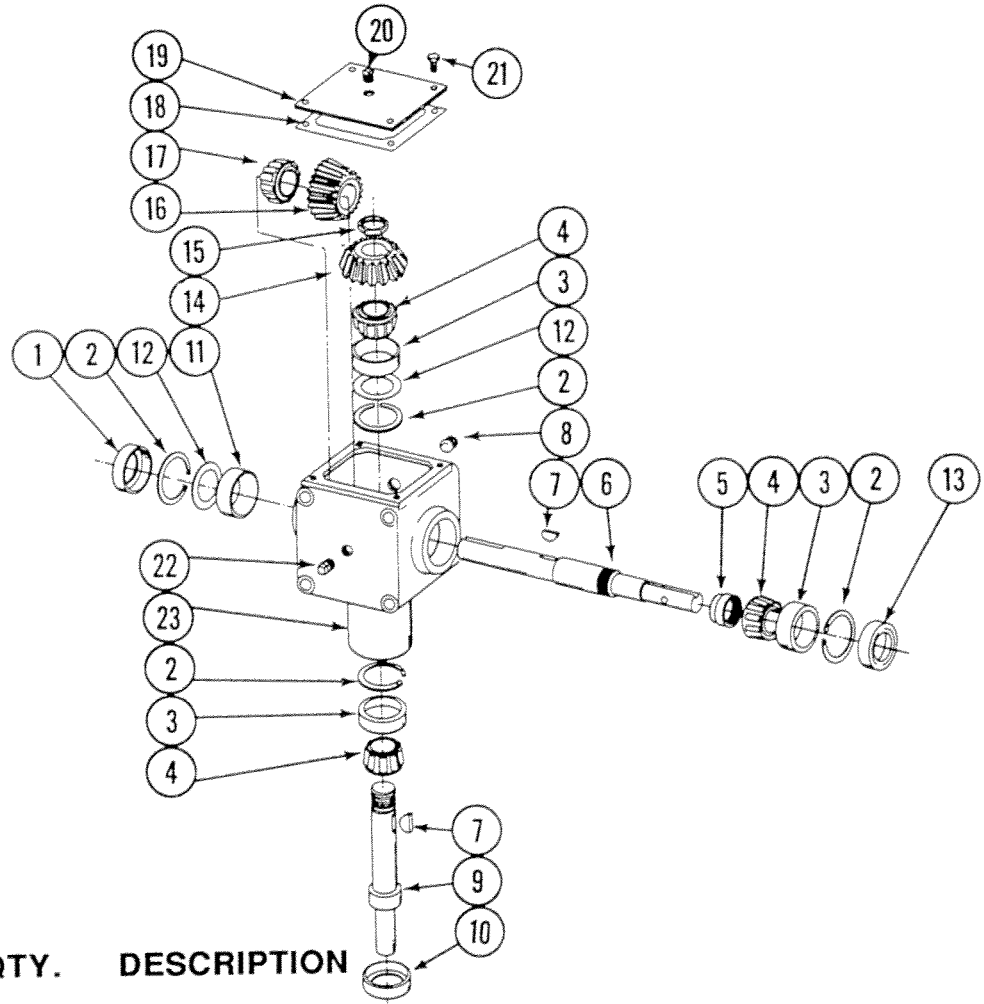

ITEM	PART NO.	QTY.	DESCRIPTION
1.	GR0339	1	Seal
2.	G10143	4	Snap Ring
3.	GR0190	3	Cup
4.	GA0714	3	Bearing
5.	GR0330	1	Stake Nut, 1 5/8"-18
6.	GR0333	1	Shaft
7.	GR0334	2	Woodruff Key
8.	G10142	1	Drain Plug, 3/8"-18 NPT
9.	GR0332	1	Shaft
10.	GR0302	1	Seal
11.	GR0340	1	Cup
12.	GR0338	-	Shim
13.	GR0335	1	Seal
14.	GR0329	1	Bevel Gear
15.	GR0331	1	Stake Nut, 1 /38"-18
16.	GR0341	1	Bevel Gear
17.	GA0715	1	Bearing
18.	GR0336	1	Gasket
19.	GR0328	1	Cover
20.	GR0306	1	Vent Plug, 3/8"-18 NPT
21.	G10018	4	Hex Head Cap Screw, 5/16"-18 x 5/8"
22.	G10121	1	Plug, 3/8"-18 NPT
23.	GR0327	1	Housing
A.	GA0406	1	Gearbox Complete (Items 1-23)

GEARBOX

840/1040

GBX001

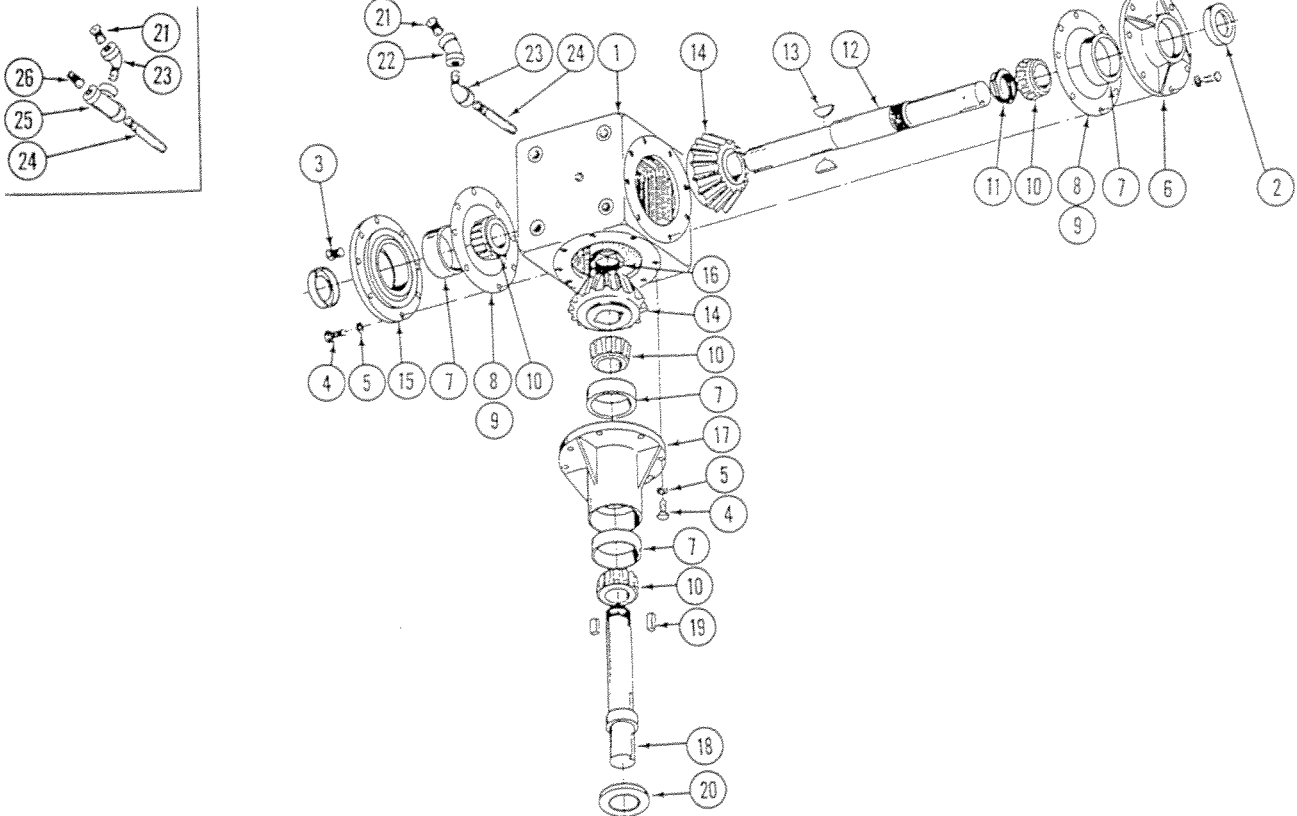

ITEM	PART NO.	QTY.	DESCRIPTION
1.	GR0291	1	Housing
2.	GR0302	2	Seal
3.	G10135	1	Plug, 1/4"-18 NPT
4.	G10037	24	Hex Head Cap Screw, 1/2"-13 x 1 1/4"
5.	G10228	24	Lock Washer, 1/2"
6.	GR0292	1	Cover
7.	GR0296	4	Cup
8.	GR0304	-	Shim
9.	GR0305	3	Gasket
10.	GA0699	4	Bearing
11.	GR0298	1	Stake Nut, 2"-18
12.	GR0300	1	Shaft
13.	GR0297	2	Woodruff Key, "G"
14.	GR0295	2	Bevel Gear
15.	GR0293	1	Cover
16.	GR0299	1	Stake Nut, 1 3/4"-18
17.	GR0294	1	Hub
18.	GR0301	1	Shaft
19.	GR0307	2	Key, 3/8" x 3/8" x 1 3/8"
20.	GR0303	1	Seal
21.	GR0306	1	Vent Plug, 3/8"-18 NPT
22.	G10122	-	Elbow, 45°
23.	G10123	1	Elbow, 3/8" 90°
24.	G10124	1	Pipe Nipple, 3/8"
25.	G10749	-	Pipe Tee, 3/8"
26.	G10142	-	Hex Socket Plug, 3/8"
A.	GA0624	-	Gearbox Complete (Items 1-21)

VERTICAL AUGER - UPPER SECTION

640

WVA007

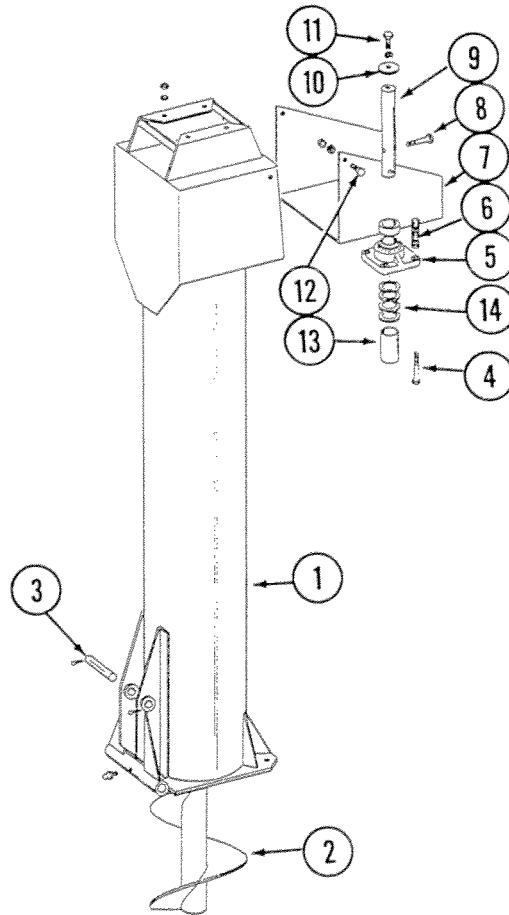

ITEM	PART NO.	QTY.	DESCRIPTION
1.	GR0966	1	Housing W/Grease Fitting
	G10641	-	Grease Fitting, 1/8" NPT
2.	GA4534	1	Auger, Right Hand, 14" x 8'
3.	GD2161	1	Pin, 1 1/4" x 8 1/4"
	G10460	2	Cotter Pin, 1/4" x 2"
4.	GD6462	4	Special Bolt, 5/8"-11 x 7"
	G10107	4	Lock Nut, 5/8"-11
5.	GA0449	1	Bearing W/Lock Collar and Grease Fitting, 2"
	G10641	-	Grease Fitting, 1/8" NPT
	GR0265	-	Lock Collar W/Set Screw
	G10080	-	Set Screw, 7/16"-14 x 7/16"
6.	GD6433	4	Spring
7.	GD6420	1	Extension
8.	G10013	2	Hex Head Cap Screw, 5/8"-11 x 3 1/2"
	G10107	2	Lock Nut, 5/8"-11
9.	GD6388	1	Shaft, 2" x 14 3/4"
10.	GD2456	1	Washer
11.	G10025	1	Hex Head Cap Screw, 3/4"-10 x 1 1/2"
	G10231	1	Lock Washer, 3/4"
12.	G10001	2	Hex Head Cap Screw, 3/8"-16 x 1"
	G10108	2	Lock Nut, 3/8"-16
13.	GD3457-06	1	Sleeve, 7 1/4"
14.	G10234	-	Machine Bushing, 10 Gauge (As Required)

VERTICAL AUGER - UPPER SECTION

840/1040

WVA004/WVA010

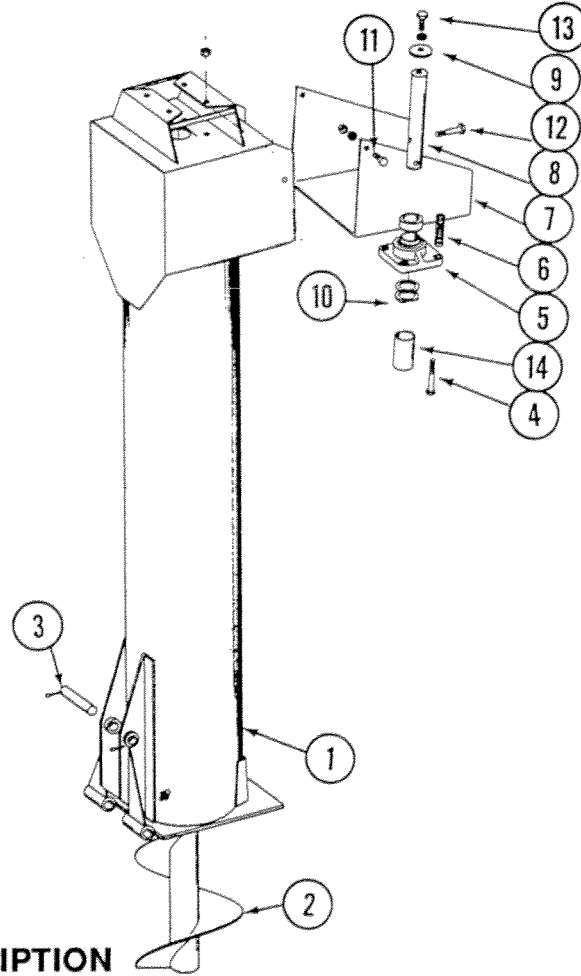

ITEM	PART NO.	QTY.	DESCRIPTION
1.	GR1060	1	Housing W/Grease Fittings
	G10641	-	Grease Fittings, 1/8" NPT
2.	GA4538	1	Auger, Right Hand, 16" x 8'
3.	GD0653	1	Pin, 1 1/4" x 7 3/4"
	G10460	2	Cotter Pin, 1/4" x 2"
4.	GD6462	4	Special Bolt, 5/8"-11 x 7"
	G10107	4	Lock Nut, 5/8"-11
5.	GA0448	1	Bearing W/Lock Collar and Grease Fittings, 2 7/16"
	G10641	-	Grease Fitting, 1/8" NPT
	GR0264	-	Lock Collar W/Set Screw
	G10080	-	Set Screw, 7/16"-14 x 7/16"
6.	GD6433	4	Spring
7.	GD8017	1	Extension
8.	GD7069	1	Shaft, 2 7/16" x 11 1/2"
9.	GD2456	1	Washer
10.	G10359	-	Machine Bushing, 18 Gauge (As Required)
	G10360	-	Machine Bushing, 10 Gauge (As Required)
11.	G10001	2	Hex Head Cap Screw, 3/8"-16 x 1"
	G10108	2	Lock Nut, 3/8"-16
12.	G10011	2	Hex Head Cap Screw, 5/8"-11 x 5 1/2"
	G10107	2	Lock Nut, 5/8"-11
13.	G10025	1	Hex Head Cap Screw, 3/4"-10 x 1 1/2"
	G10231	1	Lock Washer, 3/4"
14.	GD8038-02	-	Sleeve, 3 1/4", (Where Applicable)
	GD8038-04	-	Sleeve, 3" (Where Applicable)

VERTICAL AUGER - LOWER SECTION

640

WVA008/WVA006

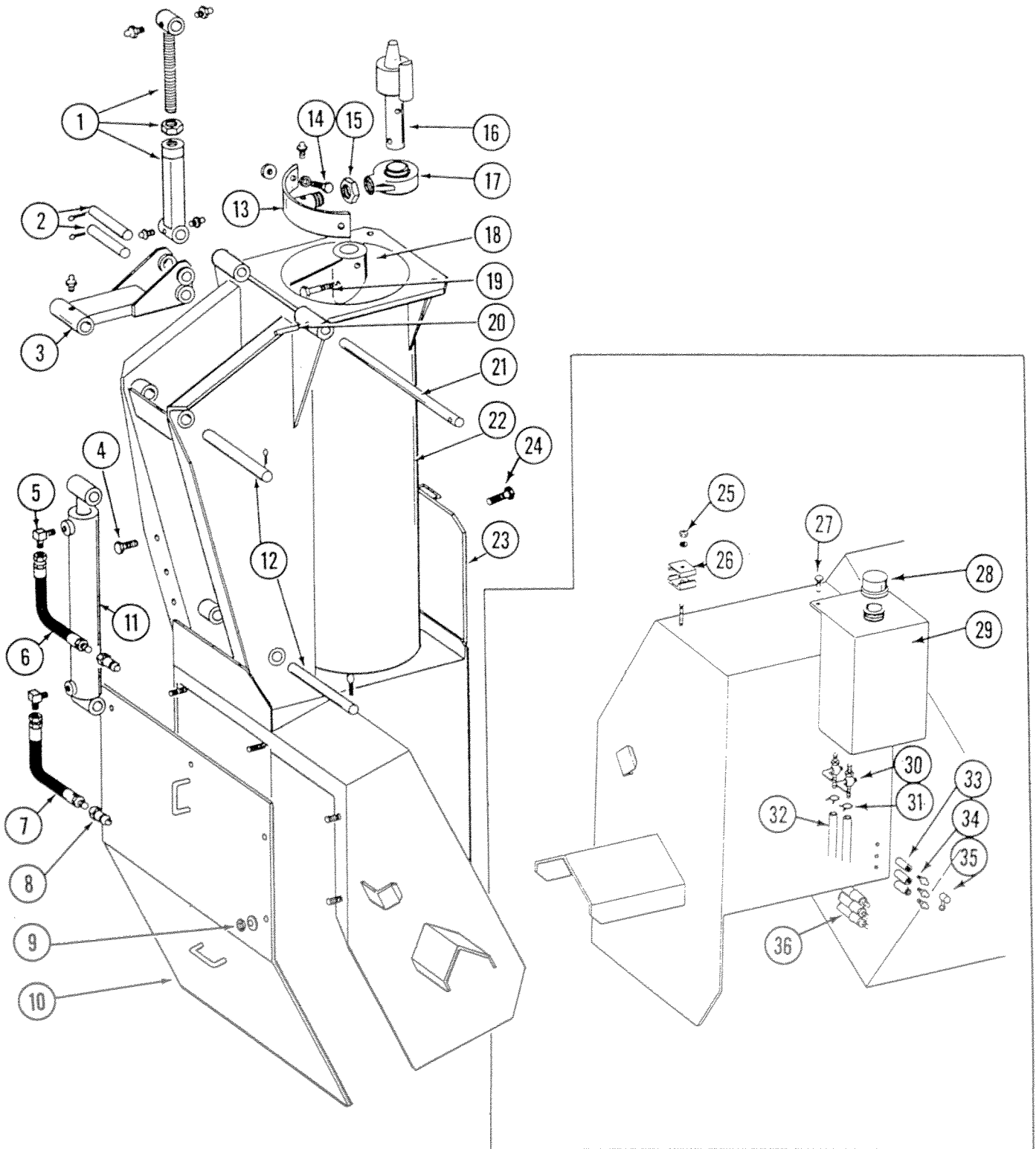

VERTICAL AUGER - LOWER SECTION

640

ITEM	PART NO.	QTY.	DESCRIPTION
1.	GA4160	1	Fold Arm W/Grease Fittings and Jam Nut
	G10641	-	Grease Fitting, 1/8" NPT
	G10087	-	Jam Nut, 1 1/2"-12
2.	GD4108	2	Pin, 1 1/4" x 7"
	G10460	4	Cotter Pin, 1/4" x 2"
3.	GA4174	1	Folding Link W/Grease Fitting
	G10641	-	Grease Fitting, 1/8" NPT
4.	G10007	-	Hex Head Cap Screw, 5/8"-11 x 1 1/2"
	G10230	-	Lock Washer, 5/8"
	G10104	-	Hex Nut, 5/8"-11
5.	G6801-06-08	2	Elbow, 9/16"-18 JIC to 3/4"-16 O-Ring
6.	GA1112	1	Hose Assembly, 1/4" x 138"
7.	GA1111	1	Hose Assembly, 1/4" x 120"
8.	GD4086	2	Pioneer Tip
9.	G10229	6	Lock Washer, 3/8"
	G10101	6	Hex Nut, 3/8"-16
10.	GA4208	1	Cover
11.	-	-	See "Vertical Auger Fold Cylinder, 640"
12.	GD4014	2	Pin, 1 1/4" x 12"
	G10460	4	Cotter Pin, 1/4" x 2"
13.	GR0965	1	Bearing Hanger W/Grease Fitting
	G10641	-	Grease Fitting, 1/8" NPT
14.	G10008	2	Hex Head Cap Screw, 5/8"-11 x 2"
	G10218	2	Washer, 5/8" USS
	G10230	2	Lock Washer, 5/8"
	G10104	2	Hex Nut, 5/8"-11
15.	G10115	1	Lock Nut, 1" NPT
16.	GA4163	1	Bullet
17.	GA0451	1	Bearing, 2"
18.	GA4535	1	Auger, Right Hand, 14" x 6' 1"
19.	G10013	2	Hex Head Cap Screw, 5/8"-11 x 3 1/2"
	G10107	2	Lock Nut, 5/8"-11
20.	G10610	1	Spring Pin, 3/8" x 2"
21.	GD6417	1	Shaft, 1 1/4" x 17"
22.	GR0967	1	Housing
23.	GA4168	1	Door
24.	G10017	2	Hex Head Cap Screw, 1/2"-13 x 1 1/2"
	G10228	2	Lock Washer, 1/2"
	G10102	2	Hex Nut, 1/2"-13
25.	G10232	-	Lock Washer, 5/16"
	G10106	-	Hex Nut, 5/16"-18
26.	GD5892	-	Hose Clamp
27.	G10019	2	Hex Head Cap Screw, 5/16"-18 x 1"
	G10232	2	Lock Washer, 5/16"
	G10219	2	Washer, 5/16" USS
	G10106	2	Hex Nut, 5/16"-18
28.	GA4112	1	Vented Cap, 1 1/2"
29.	GA4189	1	Tank
30.	GA4110	2	Hose Cock, Brass
31.	G10426	2	Hose Clamp
32.	GD6279-04	-	Clear Plastic Hose, 17"
33.	G10125	3	Pipe Coupling
34.	G10641	3	Grease Fitting, 1/8" NPT
35.	G10434	3	Cap Plug
36.	GA0504	3	Grease Hose, 24"

VERTICAL AUGER - LOWER SECTION

840/1040

WVA001/WVA011

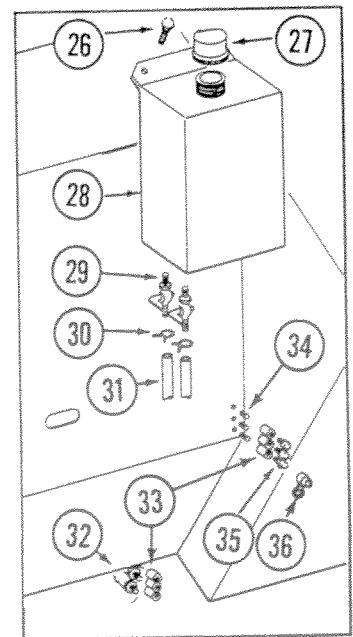
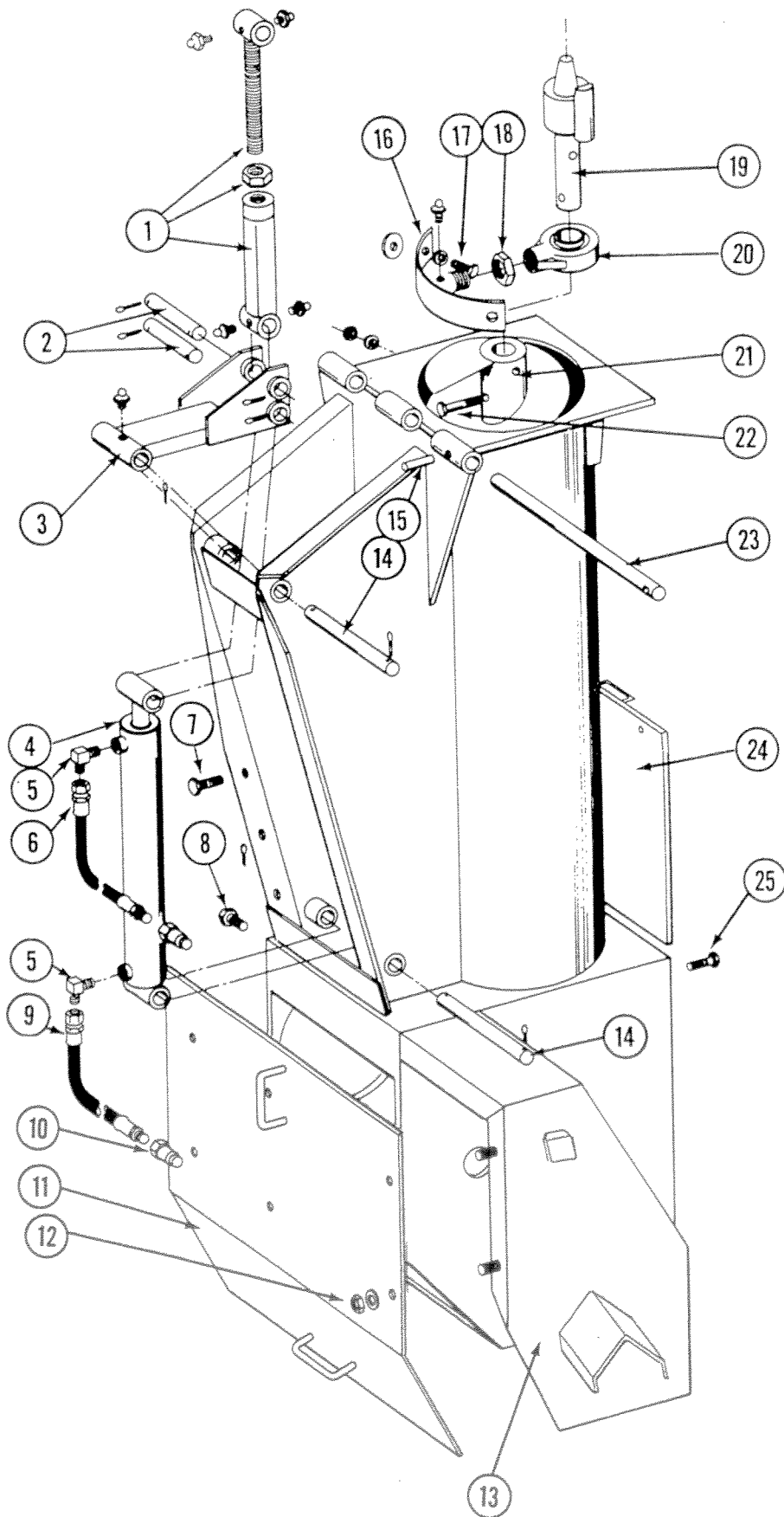

VERTICAL AUGER - LOWER SECTION

840/1040

ITEM	PART NO.	QTY.	DESCRIPTION
1.	GA4160	1	Fold Arm W/ Grease Fittings and Jam Nut
	G10641	-	Grease Fitting, 1/8" NPT
	G10087	-	Jam Nut, 1 1/2"-12
2.	GD4108	2	Pin, 1 1/4" x 7"
	G10460	4	Cotter Pin, 1/4" x 2"
3.	GA4174	1	Linkage W/Grease Fitting
	G10641	-	Grease Fitting, 1/8" NPT
4.		-	See "Vertical Auger Fold Cylinder, 840/1040"
5.	G6801-08	2	Elbow, 3/4"-16 JIC to 3/4"-16 O-Ring
6.	GA1015	1	Hose Assembly, 3/8" x 138"
7.	G10007	-	Hex Head Cap Screw, 5/8"-11 x 1 1/2"
	G10230	-	Lock Washer, 5/8"
	G10104	-	Hex Nut, 5/8"-11
8.	G10025	-	Hex Head Cap Screw, 3/4"-10 x 1 1/2"
	G10231	-	Lock Washer, 3/4"
	G10105	-	Hex Nut, 3/4"-10
9.	GA1014	1	Hose Assembly, 3/8" x 120"
10.	GD4086	2	Pioneer Tip
11.	GA5769	1	Cover
12.	G10229	6	Lock Washer, 3/8"
	G10101	6	Hex Nut, 3/8"-16
13.	GR1061	1	Housing
14.	GD4014	2	Pin, 1 1/4" x 12"
	G10460	4	Cotter Pin, 1/4" x 2"
15.	G10610	1	Spring Pin, 3/8" x 2"
16.	GA0511	1	Mount W/Grease Fitting
	G10641	-	Grease Fitting, 1/8" NPT
17.	G10016	2	Hex Head Cap Screw, 1/2"-13 x 2"
	G10216	2	Washer, 1/2" USS
	G10228	2	Lock Washer, 1/2"
	G10102	2	Hex Nut, 1/2"-13
18.	G10116	1	Lock Nut, 1 1/4" NPT
19.	GA0423	1	Bullet
20.	GA0452	1	Bearing W/Grease Fitting, 2 7/16"
	G10641	-	Grease Fitting, 1/8" NPT
21.	GA4539	1	Auger, Right Hand, 16" x 5'6"
22.	G10011	2	Hex Head Cap Screw, 5/8"-11 x 5 1/2"
	G10107	2	Lock Nut, 5/8"-11
23.	GD4012	1	Shaft, 1 1/4" x 22 3/4"
24.	GA5773	1	Door
25.	G10017	2	Hex Head Cap Screw, 1/2"-13 x 1 1/2"
	G10228	2	Lock Washer, 1/2"
	G10102	2	Hex Nut, 1/2"-13
26.	G10019	2	Hex Head Cap Screw, 5/16"-18 x 1"
	G10232	2	Lock Washer, 5/16"
	G10219	2	Washer, 5/16" USS
	G10106	2	Hex Nut, 5/16"-18
27.	GA4112	1	Vented Cap, 1 1/2"
28.	GA4108	1	Tank
29.	GA4110	2	Hose Cock, Brass
30.	G10426	2	Hose Clamp
31.	GD6279-04	-	Clear Plastic Hose, 17"
32.	GA0504	3	Grease Hose, 24"
33.	G10125	3	Pipe Coupling
34.	G10127	3	Close Nipple, 1/8" NPT x 1 1/2"
35.	G10641	3	Grease Fitting, 1/8" NPT
36.	G10434	3	Cap Plug

VERTICAL AUGER DRIVE

640

WAD005/WAD002

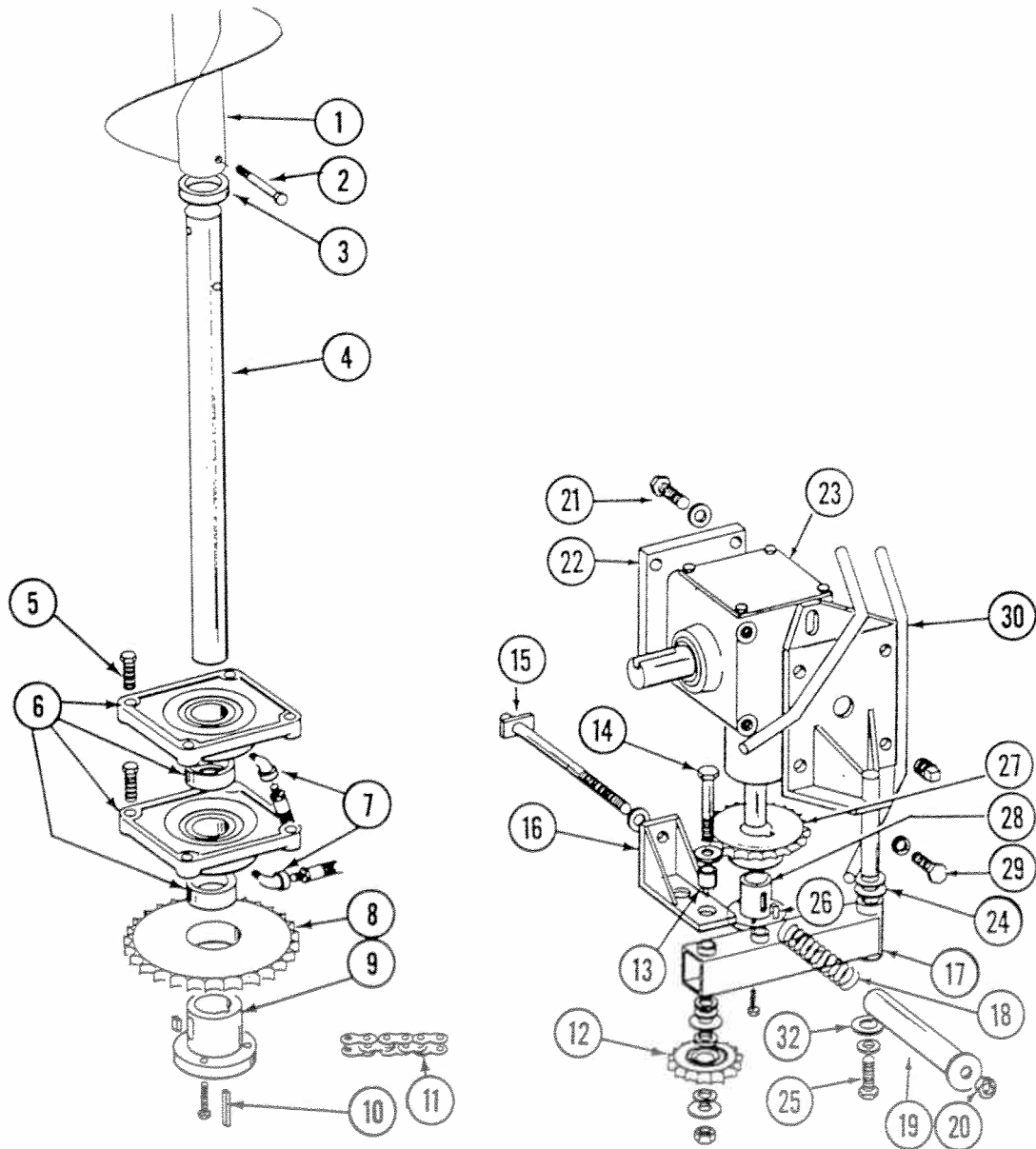

VERTICAL AUGER DRIVE

640

ITEM	PART NO.	QTY.	DESCRIPTION
1.		-	See "Vertical Auger/Lower Section, 640"
2.	G10013	2	Hex Head Cap Screw, 5/8"-11 x 3 1/2"
	G10107	2	Lock Nut, 5/8"-11
3.	GD3457-04	1	Sleeve
4.	GD6387	1	Shaft, 2" x 20"
5.	G10008	8	Hex Head Cap Screw, 5/8"-11 x 2"
	G10230	8	Lock Washer, 5/8"
	G10104	8	Hex Nut, 5/8"-11
6.	GA0449	2	Bearing W/Lock Collar, 2"
	GR0265	-	Lock Collar W/Set Screws
	G10080	-	Set Screw, 7/16"-14 x 7/16"
7.	G10423	2	Elbow, 1/8" NPT
8.	GD4117	1	Sprocket, 26 Tooth
9.	GA0713	1	Bushing W/HHCSs and Set Screw, 2"
	G10004	-	Hex Head Cap Screw, 3/8"-16 x 1 1/4"
	G10141	-	Set Screw, 1/4"-20 x 3/4"
10.	GD0148	1	Key, 1/2" x 1/2" x 2 1/2"
11.	G3304-63	1	Chain, No. 80, 63 Pitch Including Connector Link and Offset Link
	GR0197	-	Connector Link, No. 80
	GR0202	-	Offset Link, No. 80
12.	GD4119	1	Idler Sprocket W/Bearing, 12 Tooth
	GA0593	-	Bearing
13.	GD6425-01	1	Bushing
14.	G10058	1	Hex Head Cap Screw, 3/4"-10 x 5 1/2"
	G10215	5	Machine Bushing, 3/4"
	G10218	3	Washer, 3/4" USS
	G10112	1	Lock Nut, 3/4"-10
15.	GA4178	1	Idler Bolt
	G10217	1	Washer, 5/8" USS
16.	GA4179	1	Bracket
17.	GA4690	1	Arm W/Grease Fitting
	G10641	-	Grease Fitting, 1/8" NPT
18.	GD6337	1	Spring
19.	GA4180	1	Spring Housing
20.	G10730	1	Nylon Lock Nut, 5/8"-11
21.	G10039	4	Hex Head Cap Screw, 1/2"-13 x 1 3/4"
	G10228	4	Lock Washer, 1/2"
22.	GD6408	1	Spacer
23.		-	See "Gearbox, 640"
24.	G10233	-	Machine Bushing, 10 Gauge (As Required)
	G10526	-	Machine Bushing, 16 Gauge (As Required)
25.	G10438	1	Hex Head Cap Screw, 1/2"-13 x 3/4"
	G10228	1	Lock Washer, 1/2"
26.	GD0147	1	Key, 1/4" x 1/4" x 2"
27.	GD4118	1	Sprocket, 15 Tooth
28.	GD4121	1	Bushing W/HHCSs, 1 1/4"
	G10019	-	Hex Head Cap Screw, 5/16"-16 x 1"
29.	G10438	1	Hex Head Cap Screw, 1/2"-13 x 3/4"
	G10228	1	Lock Washer, 1/2"
30.	GA4734	1	Idler Plate

VERTICAL AUGER DRIVE

840/1040

WAD002/WAD006

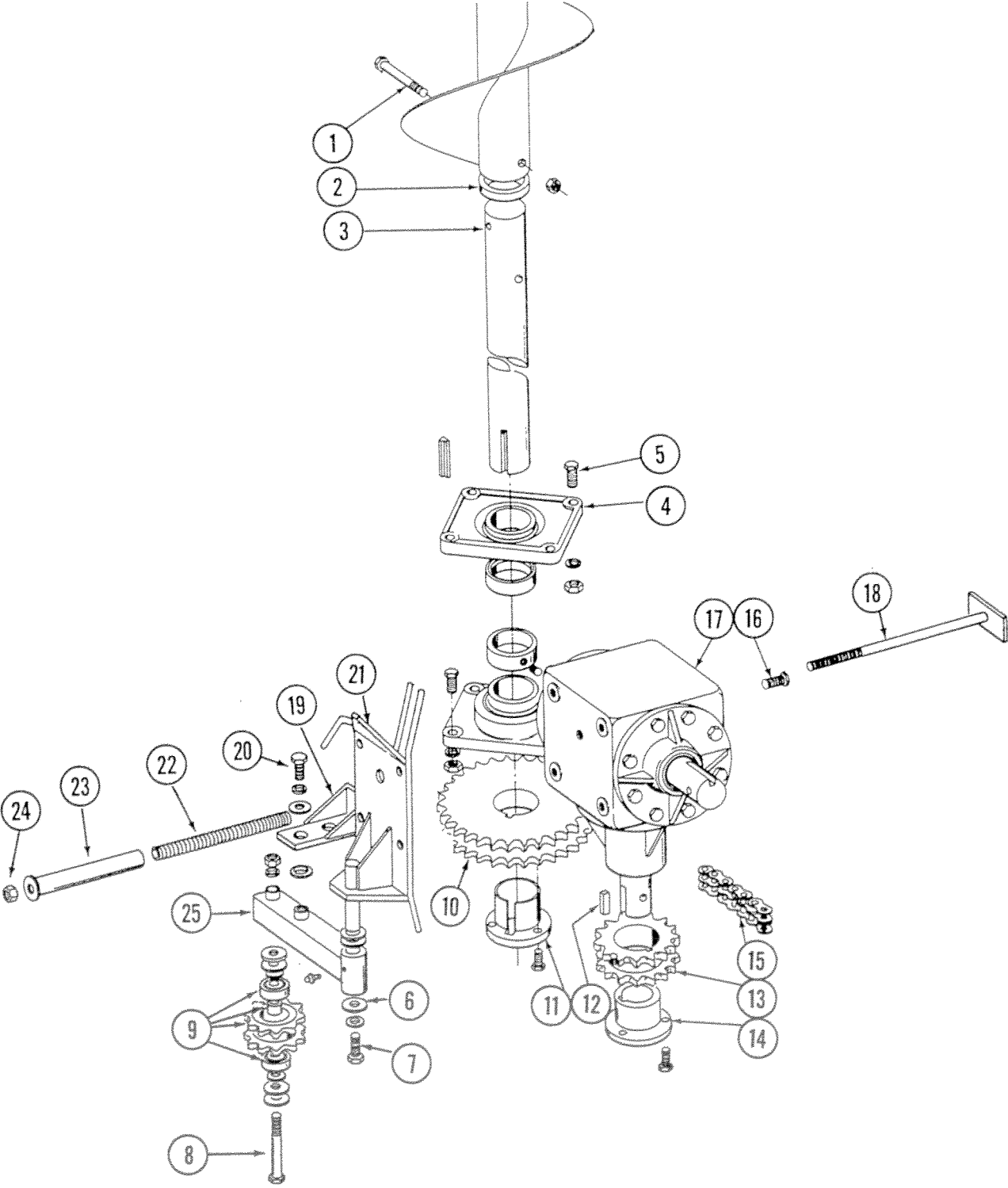

VERTICAL AUGER DRIVE

840/1040

ITEM	PART NO.	QTY.	DESCRIPTION
1.	G10011	2	Hex Head Cap Screw, 5/8"-11 x 5 1/2"
	G10107	2	Lock Nut, 5/8"-11
2.	GD8038-03	1	Spacer, 1 3/4"
3.	GD6885	1	Shaft, 2 7/16" x 22"
4.	GA0448	2	Bearing W/Lock Collar, Set Screw and Grease Fitting, 2 7/16"
	GR0264	-	Lock Collar, 2 7/16"
	G10080	-	Set Screw, 7/16"-14 x 7/16"
	G10641	-	Grease Fitting, 1/8" NPT
5.	G10008	8	Hex Head Cap Screw, 5/8"-11 x 2"
	G10230	8	Lock Washer, 5/8"
	G10104	8	Hex Nut, 5/8"-11
6.	G10233	-	Machine Bushing, 10 Gauge (As Required)
	G10526	-	Machine Bushing, 18 Gauge (As Required)
7.	G10438	1	Hex Head Cap Screw, 1/2"-13 x 3/4"
	G10228	1	Lock Washer, 1/2"
8.	G10058	1	Hex Head Cap Screw, 3/4"-10 x 5 1/2"
	G10215	5	Machine Bushing, 3/4"
	G10218	3	Washer, 3/4" USS
	G10112	1	Lock Nut, 3/4"-10
9.	GA0447	1	Idler Sprocket W/Spacer and Bearings
	GR0259	-	Spacer
	GA0593	-	Bearing
10.	GD1357	1	Sprocket, 30 Tooth
11.	GD1358	1	Bushing W/HHCSs and Key, 2 7/16"
	GR0258	-	Offset Key
	G10004	-	Hex Head Cap Screw, 3/8"-16 x 1 1/4"
12.	GD0144	1	Key, 3/8" x 3/8" x 2 1/2"
	GD9231	-	Key, 3/8" x 3/8" x 1 7/8"
13.	GD4077	1	Sprocket, 16 Tooth
14.	GD4079	1	Bushing W/HHCSs, 1 3/4"
	G10004	-	Hex Head Cap Screw, 3/8"-16 x 1 1/4"
	G3301-65	1	Chain, No. 80-2, 65 Pitch Including Connector and Offset Link
15.	GR0206	-	Offset Link, No. 80-2
	GR0198	-	Connector Link, No. 80-2
	G10055	4	Hex Head Cap Screw, 5/8"-11 x 1 1/4"
16.		-	See "Gearbox, 840/1040"
17.		-	
18.	GA4178	1	Idler Bracket
19.	GA4691	1	Bracket
20.	G10543	1	Hex Head Adjusting Bolt, 3/4"-10 x 3"
	G10231	1	Lock Washer, 3/4"
	G10218	2	Washer, 3/4" USS
21.	GA4692	1	Idler Plate
22.	GD6337	1	Spring
23.	GA4180	1	Spring Housing
24.	G10730	1	Nylon Lock Nut, 5/8"-11
25.	GA4690	1	Arm W/Grease Fitting
	G10641	-	Grease Fitting, 1/8" NPT

WAD004

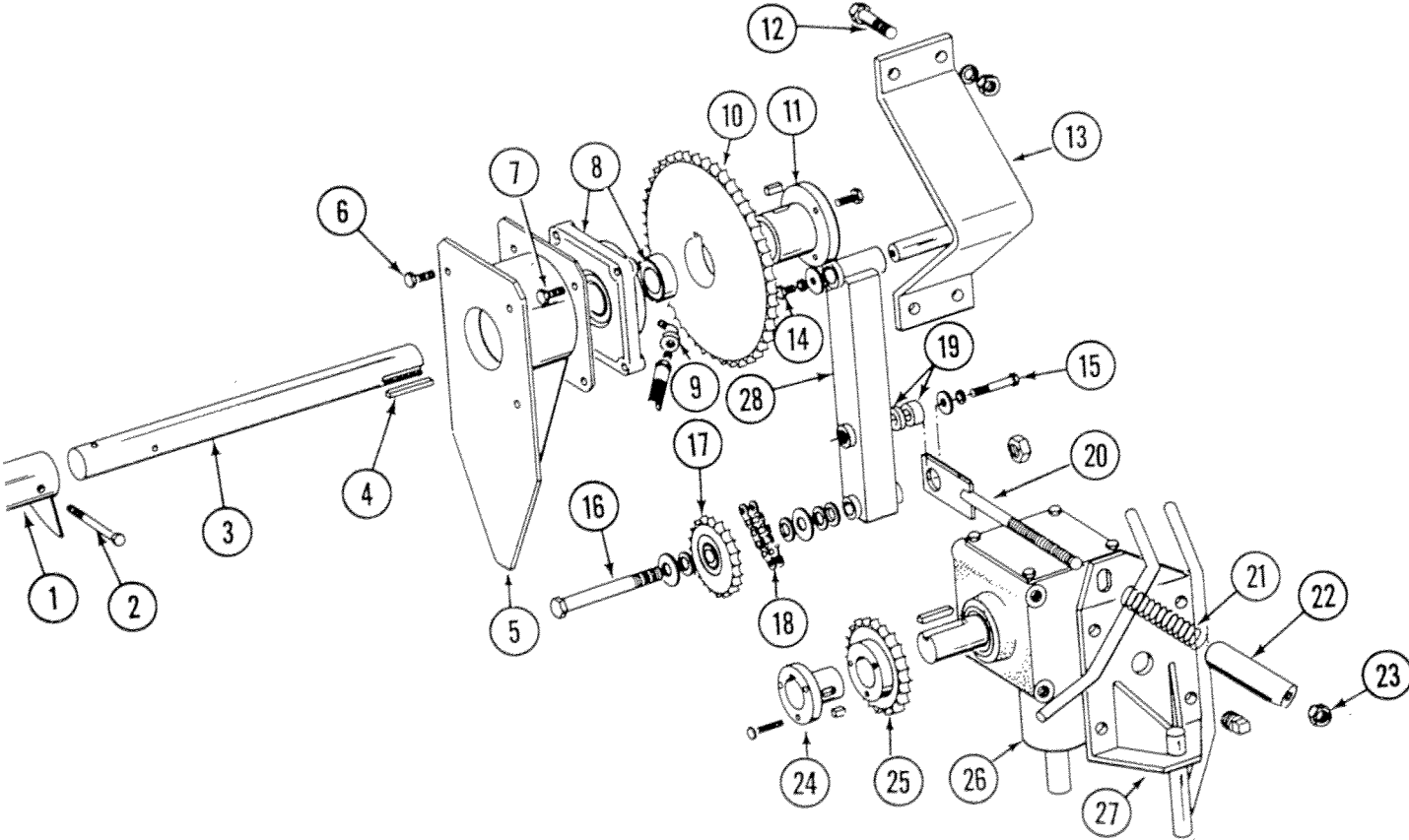

HORIZONTAL AUGER DRIVE

640

ITEM	PART NO.	QTY.	DESCRIPTION
1.		-	See "Horizontal Augers And Bearings, 640"
2.	G10013	2	Hex Head Cap Screw, 5/8"-11 x 3 1/2"
	G10107	2	Lock Nut, 5/8"-11
3.	GD1346	1	Shaft, 2" x 18 1/2"
4.	GD0148	1	Key, 1/2" x 1/2" x 2 1/2"
5.	GA4171	1	Bearing Spacer
6.	G10055	4	Hex Head Cap Screw, 5/8"-11 x 1 1/4"
	G10230	4	Lock Washer, 5/8"
	G10104	4	Hex Nut, 5/8"-11
7.	G10005	4	Hex Head Cap Screw, 5/8"-11 x 1 3/4"
	G10230	4	Lock Washer, 5/8"
	G10104	4	Hex Nut, 5/8"-11
8.	GA0449	1	Bearing W/Lock Collar, 2"
	GR0265	-	Lock Collar W/Set Screws
	G10080	-	Set Screw, 7/16"-14 x 7/16"
9.	G10423	1	Elbow, 1/8" NPT
10.	GD6392	1	Sprocket, 34 Tooth
11.	GD4123	1	Bushing W/HHCSs, 2"
	G10004	-	Hex Head Cap Screw, 3/8"-16 x 1 1/4"
12.	G10017	4	Hex Head Cap Screw, 1/2"-13 x 1 1/2"
	G10228	4	Lock Washer, 1/2"
	G10102	4	Hex Nut, 1/2"-13
13.	GA4182	1	Upper Mounting Plate
14.	G10438	1	Hex Head Cap Screw, 1/2"-13 x 3/4"
	G10228	1	Lock Washer, 1/2"
15.	G10028	1	Hex Head Cap Screw, 3/4"-10 x 3"
	G10215	1	Machine Bushing, 3/4"
	G10218	1	Washer, 3/4" USS
16.	G10058	1	Hex Head Cap Screw, 3/4"-10 x 5 1/2"
	G10215	5	Machine Bushing, 3/4"
	G10218	3	Washer, 3/4" USS
	G10112	1	Lock Nut, 3/4"-10
17.	GD4119	1	Idler Sprocket W/Bearing
	GA0531	-	Bearing
18.	G3304-51	1	Chain, No. 80, 51 Pitch Including Connector Link and Offset Link
	GR0197	-	Connector Link, No. 80
	GR0202	-	Offset Link, No. 80
19.	GD6425-01	2	Bushing
20.	GA4177	1	Idler Bar
21.	GD6337	1	Spring
22.	GA4180	1	Spring Housing
23.	G10730	1	Nylon Lock Nut, 5/8"-11
24.	GD4120	1	Bushing W/HHCSs and Key, 1 1/2"
	G10019	-	Hex Head Cap Screw, 5/16"-16 x 1"
	GR0361	-	Key
25.	GD4118	1	Sprocket, 15 Tooth
26.		-	See "Gearbox, 640"
27.		-	See "Vertical Auger Drive, 640"
28.	GA4690	1	Arm W/Grease Fitting
	G10641	-	Grease Fitting, 1/8" NPT

HORIZONTAL AUGER DRIVE

840/1040

WAD003/WAD006WHA002

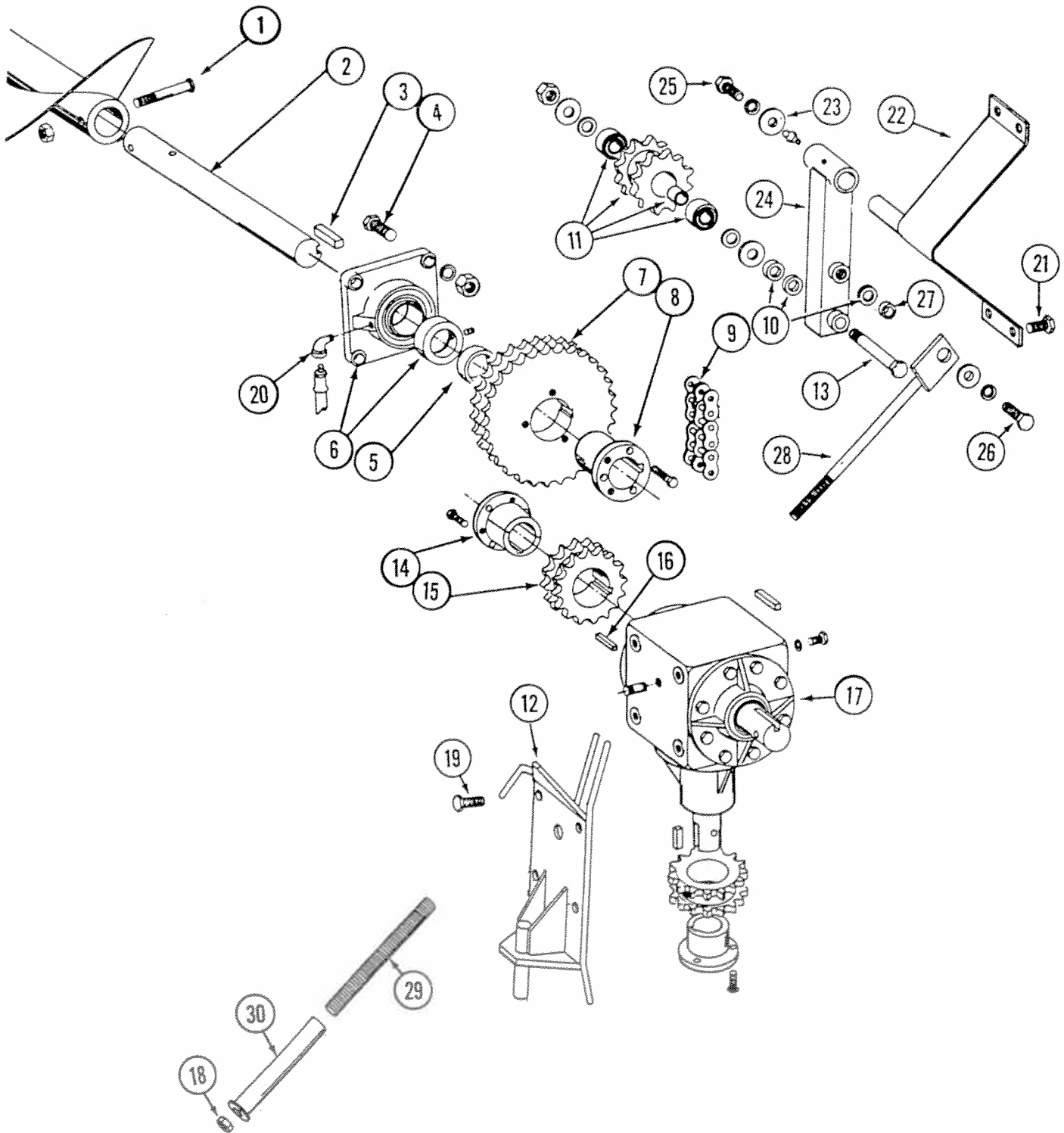

HORIZONTAL AUGER DRIVE

840/1040

ITEM	PART NO.	QTY.	DESCRIPTION
1.	G10036	2	Hex Head Cap Screw, 5/8"-11 x 4"
	G10107	2	Lock Nut, 5/8"-11
2.	GD1346	1	Shaft, 2" x 18 1/2"
3.	GD1435	1	Key, 1/2" x 1/2" x 3"
4.	G10009	4	Hex Head Cap Screw, 5/8"-11 x 2 1/2"
	G10230	4	Lock Washer, 5/8"
	G10104	4	Hex Nut, 5/8"-11
5.	GD4016	1	Spacer
6.	GA0449	1	Bearing W/Lock Collar, 2"
	GR0265	-	Lock Collar W/Set Screws
	G10080	-	Set Screw, 7/16"-14 x 7/16"
7.	GD1357	1	Sprocket, 30 Tooth
8.	GD4123	1	Bushing W/HHCSs, 2"
	G10004	-	Hex Head Cap Screw, 3/8"-16 x 1 1/4"
9.	G3301-47	1	Chain, No. 80-2, 47 Pitch Including Connector and Offset Link
	GR0206	-	Offset Link, No. 80-2
	GR0198	-	Connector Link, No. 80-2
10.	GD2951	3	Sleeve
11.	GA0447	1	Sprocket W/Spacer and Bearings
	GA0593	-	Bearing
	GR0259	-	Spacer
12.		-	See "Vertical Auger Drive, 840"
13.	G10400	1	Hex Head Cap Screw, 3/4"-10 x 6 1/2"
	G10215	2	Machine Bushing, 3/4"
	G10218	2	Washer, 3/4" USS
	G10112	1	Lock Nut, 3/4"-10
14.	GD4079	1	Bushing W/HHCSs, 1 3/4"
	G10004	-	Hex Head Cap Screw, 3/8"-16 x 1 1/4"
15.	GD4077	1	Sprocket, 16 Tooth
16.	GD0144	1	Key, 3/8" x 3/8" x 2 1/2"
	GD9221	-	Key, 3/8" x 3/8" x 1 7/8"
17.		-	See "Gearbox, 840/1040"
18.	G10730	1	Nylon Lock Nut, 5/8"-11
19.	G10443	4	Hex Head Cap Screw, 5/8"-11 x 1"
20.	G10423	1	Elbow, 1/8" NPT
21.	G10017	4	Hex Head Cap Screw, 1/2"-13 x 1 1/2"
	G10228	4	Lock Washer, 1/2"
	G10102	4	Hex Nut, 1/2"-13
22.	GA4182	1	Upper Mounting Plate
23.	G10233	-	Machine Bushing, 10 Gauge (As Required)
	G10526	-	Machine Bushing, 18 Gauge (As Required)
24.	GA4690	1	Arm W/Grease Fitting
	G10641	-	Grease Fitting, 1/8" NPT
25.	G10438	1	Hex Head Cap Screw, 1/2"-13 x 3/4"
	G10228	1	Lock Washer, 1/2"
26.	G10028	1	Hex Head Cap Screw, 3/4"-10 x 3"
	G10231	1	Lock Washer, 3/4"
	G10218	1	Washer, 3/4" USS
27.	GD6425-01	1	Bushing
28.	GA4177	1	Idler Bar
29.	GD6337	1	Spring
30.	GA4180	1	Spring Housing

HORIZONTAL AUGERS AND BEARINGS

640

WHA003/WHA004

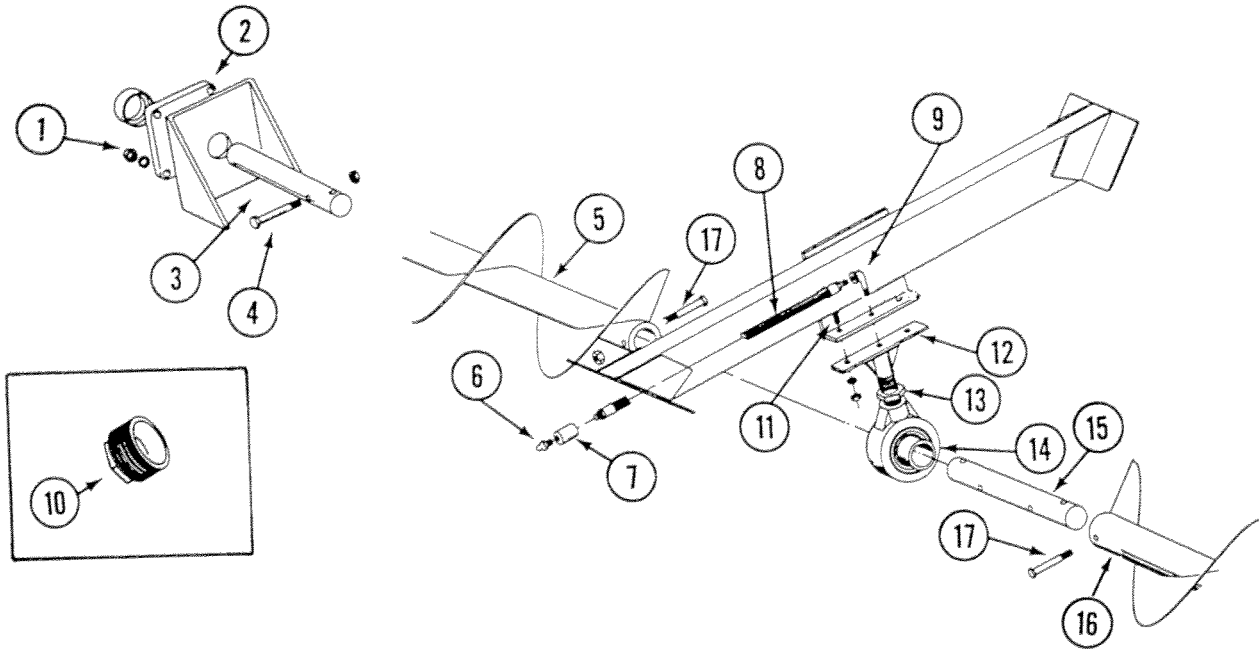

ITEM	PART NO.	QTY.	DESCRIPTION
1.	G10228	4	Lock Washer, 1/2"
	G10102	4	Hex Nut, 1/2"-13
2.	GA0450	1	Bearing W/Lock Collar and Grease Fitting, 1 1/2"
	G10641	-	Grease Fitting, 1/8" NPT
	GR0266	-	Lock Collar W/Set Screws
	G10072	-	Set Screw, 3/8"-16 x 3/8"
3.	GD1447	1	Shaft, 1 1/2" x 16 1/2"
4.	G10033	2	Hex Head Cap Screw, 1/2"-13 x 3 1/2"
	G10111	2	Lock Nut, 1/2"-13
5.	GA4533	1	Rear Auger, Left Hand, 12" x 6'
6.	G10641	1	Grease Fitting, 1/8" NPT
7.	G10125	1	Pipe Coupling, 1/8" NPT
8.	GA0504	1	Grease Hose, 24"
9.	G10423	1	Elbow, 1/8"
10.	G10185	1	Pipe Plug, 2" (Located in bottom of wagon)
11.	G10039	2	Hex Head Cap Screw, 1/2"-13 x 1 3/4"
	G10228	2	Lock Washer, 1/2"
	G10102	2	Hex Nut, 1/2"-13
12.	GA4147	1	Bracket
13.	G10115	1	Lock Nut, 1" NPT
14.	GA0451	1	Hanger Bearing, 2"
15.	GD4010	1	Shaft, 2" x 13 1/2"
16.	GA4532	1	Front Auger, Left Hand, 12" x 7' 2 1/2"
17.	G10036	4	Hex Head Cap Screw, 5/8"-11 x 4"
	G10107	4	Lock Nut, 5/8"-11

HORIZONTAL AUGERS AND BEARINGS

840/1040

WHA002/WHA004/WTC011

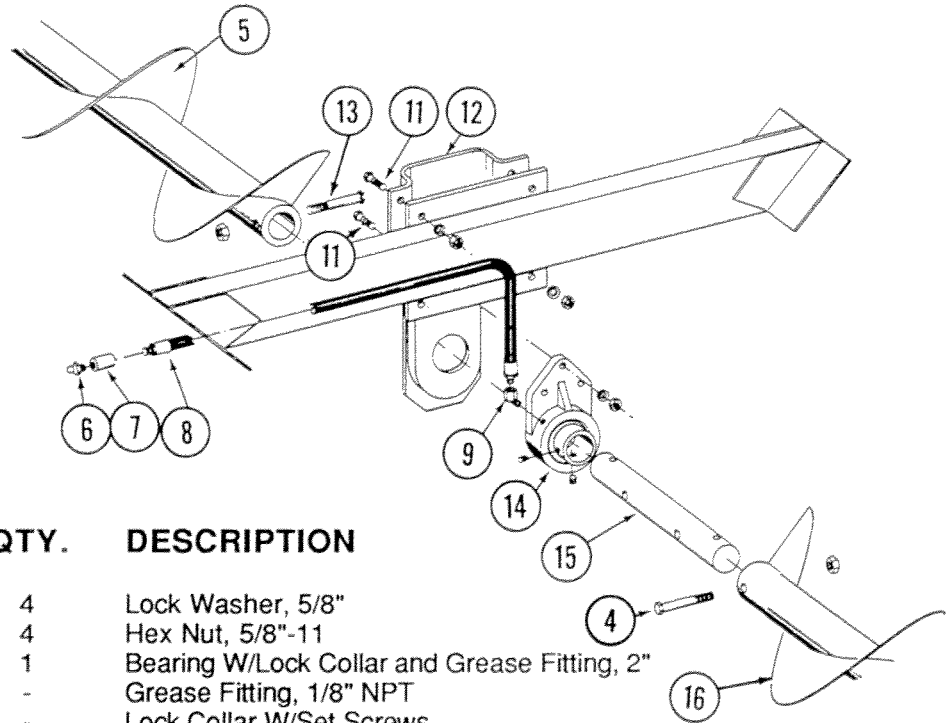
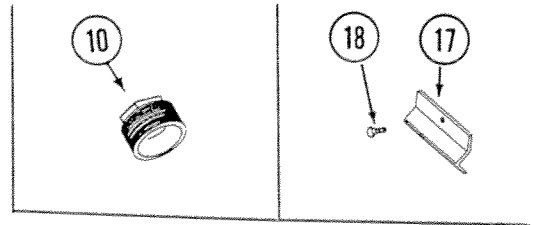
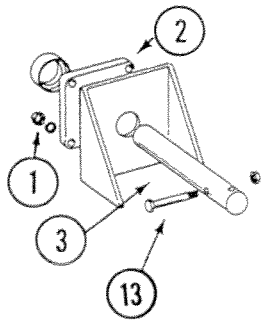

ITEM	PART NO.	QTY.	DESCRIPTION
1.	G10230	4	Lock Washer, 5/8"
	G10104	4	Hex Nut, 5/8"-11
2.	GA0449	1	Bearing W/Lock Collar and Grease Fitting, 2"
	G10641	-	Grease Fitting, 1/8" NPT
	GR0265	-	Lock Collar W/Set Screws
	G10080	-	Set Screw, 7/16"-14 x 7/16"
3.	GD1347	1	Shaft, 2" x 13"
4.	G10318	2	Hex Head Cap Screw, 5/8"-11 x 4 1/2"
	G10107	2	Lock Nut, 5/8"-11
5.	GA4537	1	Rear Auger, Left Hand, 12" x 8'
6.	G10641	1	Grease Fitting, 1/8" NPT
7.	G10125	1	Pipe Coupling, 1/8" NPT
8.	GA0504	1	Grease Hose, 24", Wheel, Scale and Sof-Trak Wagons
	GA5852	-	Grease Hose, 48", Row Crop Wagons
9.	G5503-02-02	1	Elbow, 45°
10.	G10185	1	Pipe Plug, 2" (Located in bottom of wagon)
11.	G10017	4	Hex Head Cap Screw, 1/2"-13 x 1 1/2"
	G10228	4	Lock Washer, 1/2"
	G10102	4	Hex Nut, 1/2"-13
12.	GA0685	1	Bracket
13.	G10036	4	Hex Head Cap Screw, 5/8"-11 x 4"
	G10107	4	Lock Nut, 5/8"-11
14.	GA0517	1	Hanger Bearing W/Set Screws and Grease Fitting, 2"
	G10132	-	Set Screw, 3/8"-24 x 5/16"
	G10641	-	Grease Fitting, 1/8" NPT
15.	GD4010	1	Shaft, 2" x 13 1/2"
16.	GA4536	1	Front Auger, Left Hand, 12" x 11' 2"
17.	GD8219	-	Grease Hose Hold Down, Row Crop Wagons Only
18.	G10001	-	Hex Head Cap Screw, 3/8"-16 x 1"
	G10229	-	Lock Washer, 3/8"
	G10101	-	Hex Nut, 3/8"-16

WTC003/WTC006

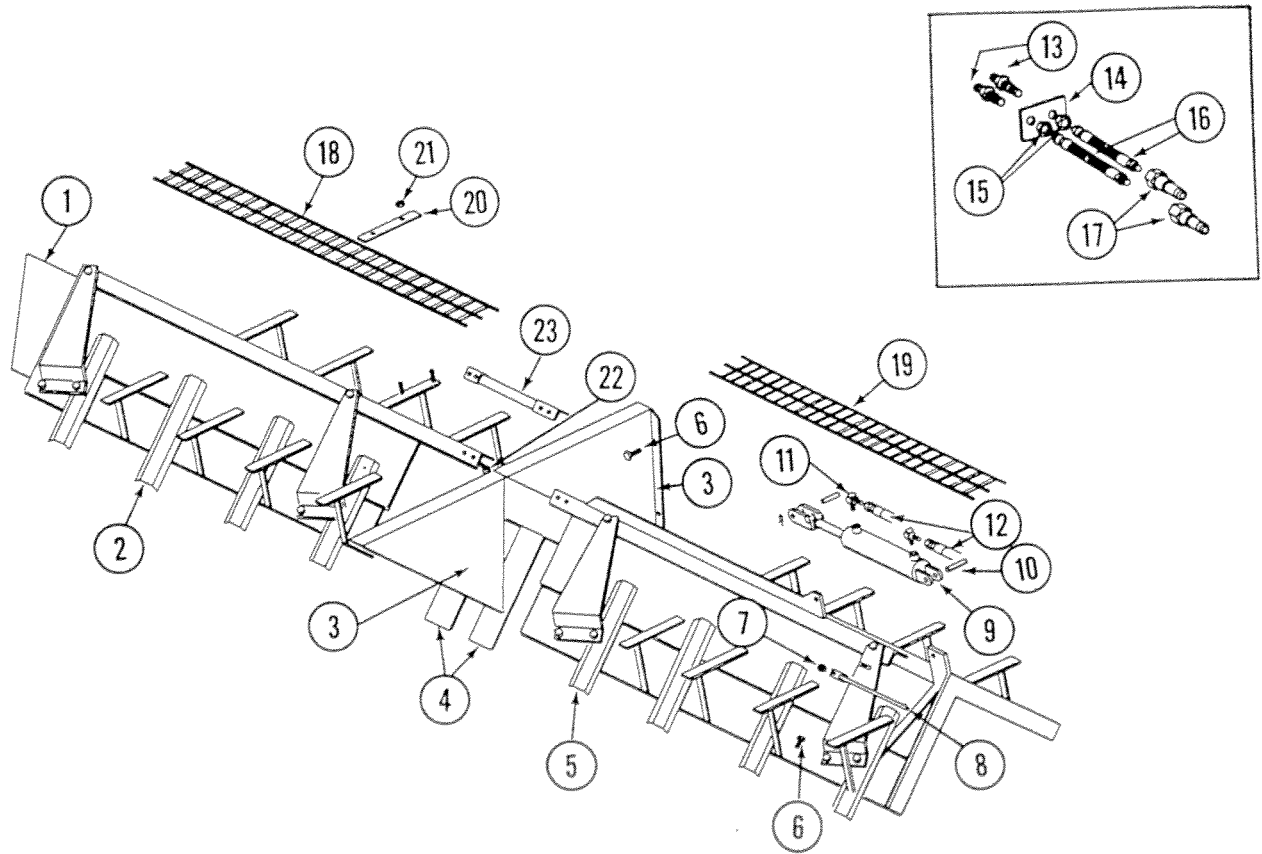

ITEM	PART NO.	QTY.	DESCRIPTION
1.	GD6307	1	Cap
2.	GA4134	1	Rear Tunnel Cover Assembly
3.	GD6308	2	Bearing Cover
4.	GD6309	1	Plate, 6"
	GD6985	1	Plate, 7"
5.	GA4135	1	Front Tunnel Cover Assembly
6.	G10001	16	Hex Head Cap Screw, 3/8"-16 x 1"
	G10229	16	Lock Washer, 3/8"
	G10101	16	Hex Nut, 3/8"-16
7.	G10111	1	Lock Nut, 1/2"-13
8.	GA4085	1	Sight Gauge Rod
9.	-	-	See "Grain Flow Control Cylinder, 640"
10.	GR0962	2	Pin, 1" x 3 3/8"
	GR0193	4	Hair Pin Clip
11.	G6801-06-08	2	Elbow
12.	GA1137	2	Hose Assembly, 1/4" x 23"
13.	G2700-06-06	2	Bulkhead Tube Unit, 9/16"-18
14.	GD6322	1	Plate
15.	G306-06	2	Lock Nut, 9/16"-18
16.	GA1111	2	Hose Assembly, 1/4" x 120"
17.	GD4086	2	Pioneer Tip
18.	GA4186	1	Rear Screen, 78"
19.	GA4185	1	Front Screen, 66"
20.	GD6447	12	Clamp
21.	G10108	24	Lock Nut, 3/8"-16
22.	G10017	8	Hex Head Cap Screw, 1/2"-13 x 1 1/2"
	G10228	8	Lock Washer, 1/2"
	G10102	8	Hex Nut, 1/2"-13
23.	GA4088	1	Tie

WTC007/WTC011

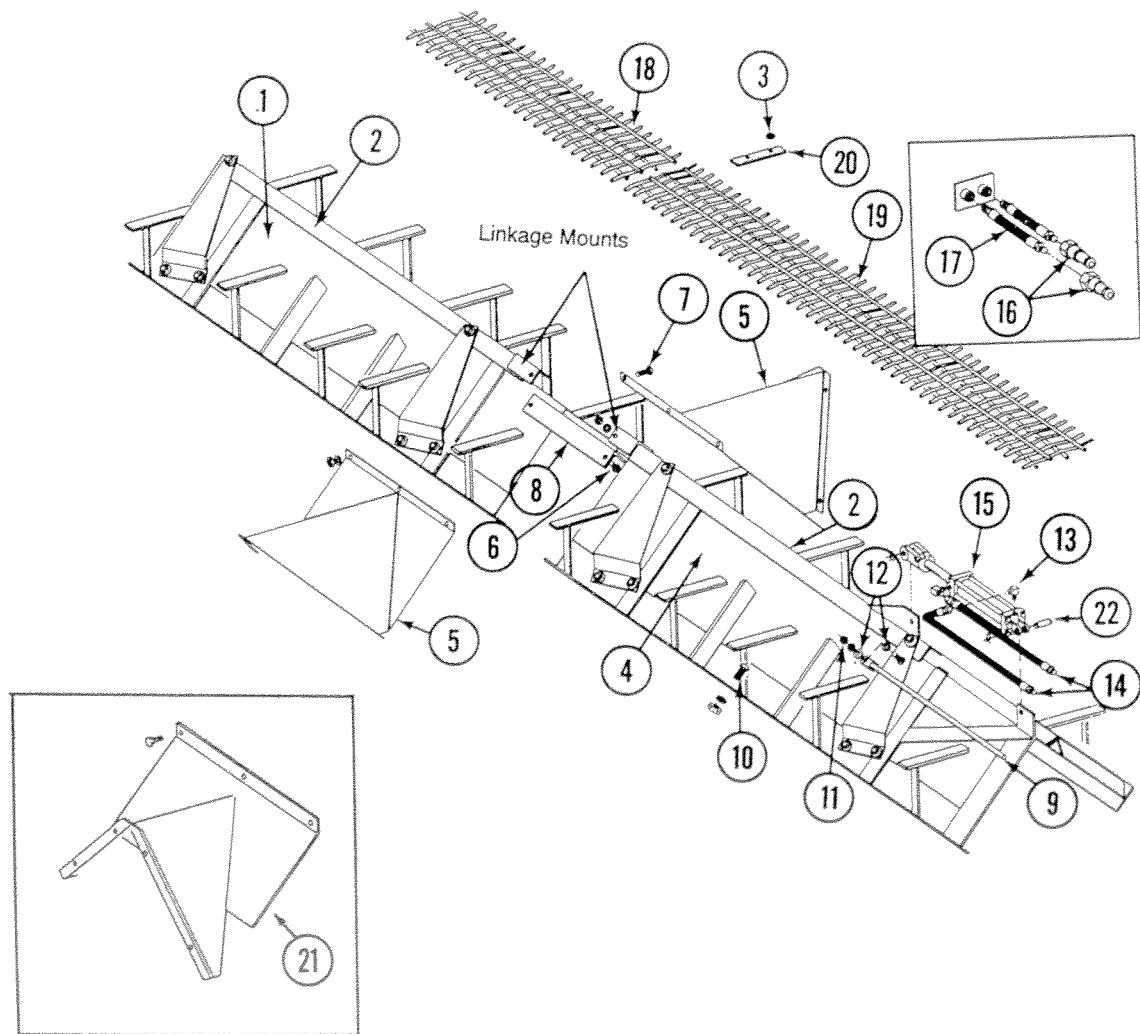

GRAIN FLOW CONTROL GATE

840/1040

ITEM	PART NO.	QTY.	DESCRIPTION
1.	GA4719	1	Rear Tunnel Cover Assembly (Includes Item 2 Less Linkage Mount), Wheel, Scale and Sof-Trak Wagons (Shown)
	GA5860	-	Rear Tunnel Cover Assembly (Includes Item 2 Less Linkage Mount), Row Crop Wagons
2.	GA1539	2	Linkage Arm
3.	G10108	16	Lock Nut, 3/8"-16
4.	GA4718	1	Front Tunnel Cover Assembly (Includes Item 2 Less Linkage Mount), Wheel, Scale and Sof-Trak Wagons (Shown)
	GA5859	-	Front Tunnel Cover Assembly (Includes Item 2 Less Linkage Mount), Row Crop Wagons
5.	GA0696	2	Bearing Cover, Wheel, Scale and Sof-Trak Wagons
6.	G10025	4	Hex Head Cap Screw, 3/4"-10 x 1 1/2"
	G10231	4	Lock Washer, 3/4"
	G10105	4	Hex Nut, 3/4"-10
7.	G10001	6	Hex Head Cap Screw, 3/8"-16 x 1"
	G10229	6	Lock Washer, 3/8"
	G10101	6	Hex Nut, 3/8"-16
8.	GD4061	1	Connector Arm
9.	GA0686	1	Rod
10.	G10004	36	Hex Head Cap Screw, 3/8"-16 x 1 1/4"
	G10229	36	Lock Washer, 3/8"
	G10101	36	Hex Nut, 3/8"-16
11.	G10102	1	Hex Nut, 1/2"-13
12.	G10216	2	Washer, 1/2" USS
13.	G6801-08	2	Elbow, 90°
14.	GA1017	2	Hose Assembly, 3/8" x 24"
15.		-	See "Grain Flow Control Gate Cylinder, 840/1040"
16.	GD4086	2	Pioneer Tip
17.	GA1016	2	Hose Assembly, 3/8" x 120"
18.	GA4698	1	Rear Screen, 96", Wheel, Scale and Sof-Trak Wagons (Shown)
	GA5858	-	Rear Screen, 96", Row Crop Wagons
19.	GA4697	1	Front Screen, 108", Wheel, Scale and Sof-Trak Wagons (Shown)
	GA5857	-	Front Screen, 108", Row Crop Wagons
20.	GD7071	8	Clamp, 1" x 10 1/2"
	GD8221	2	Clamp, 1" x 5 1/4", Row Crop Wagons Only
21.	GA5813	2	Bearing Cover, Row Crop Wagons Only
22.	GR0962	2	Pin, 1" x 3 3/8"
	GR0193	4	Hair Pin Clip

GRAIN TANK PANELS

640

WTP003/WTP008

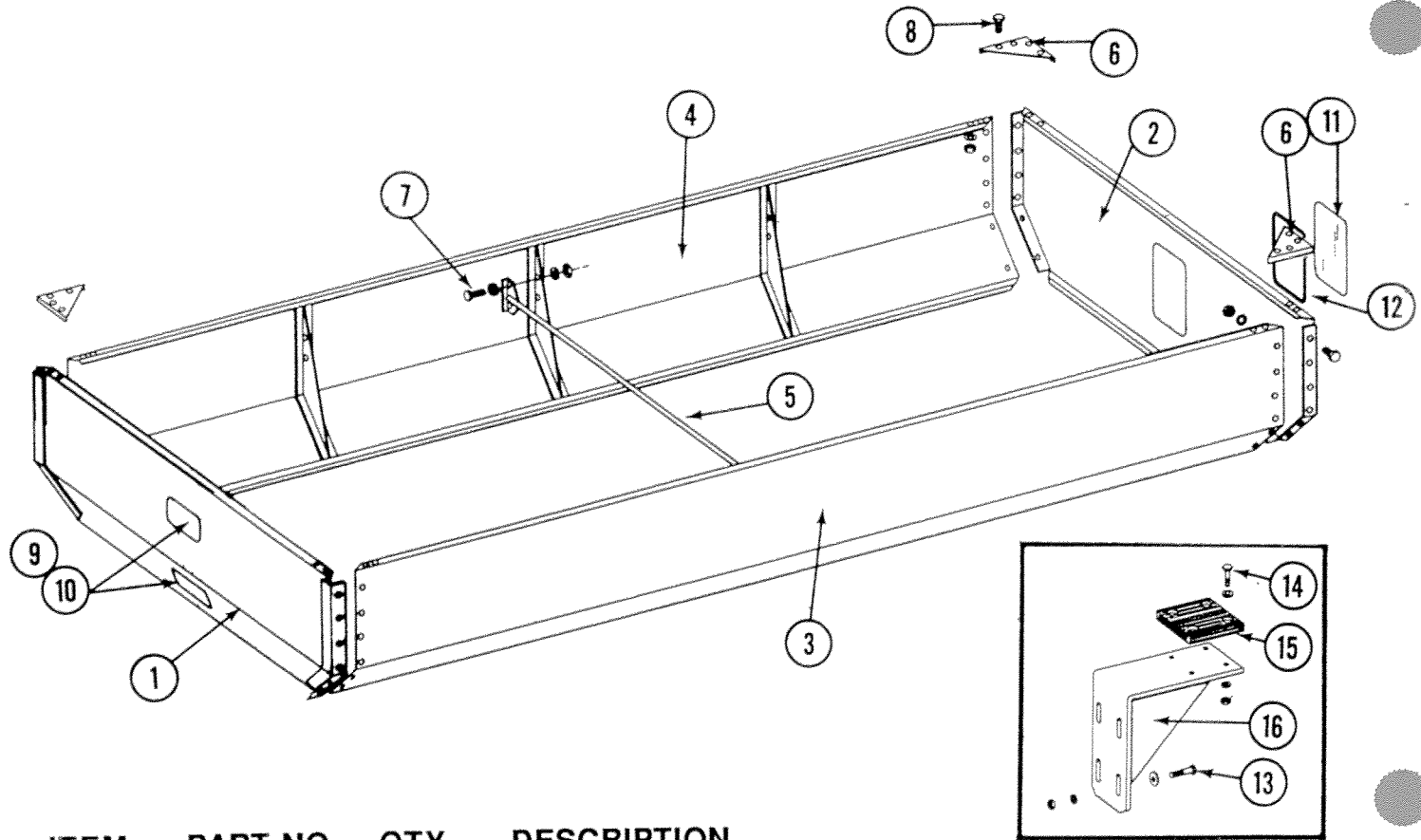

ITEM	PART NO.	QTY.	DESCRIPTION
1.	GA4151	1	Rear Panel
2.	GA4152	1	Front Panel
3.	GA4156	1	Side Panel, R.H.
4.	GA4155	1	Side Panel, L.H.
5.	GA4688	3	Cross Brace, 119"
6.	GD0327	4	Corner Cap
7.	G10017	-	Hex Head Cap Screw, 1/2"-13 x 1 1/2"
	G10216	-	Washer, 1/2" USS
	G10228	-	Lock Washer, 1/2"
	G10102	-	Hex Nut, 1/2"-13
8.	G10001	16	Hex Head Cap Screw, 3/8"-16 x 1"
	G10229	16	Lock Washer, 3/8"
	G10101	16	Hex Nut, 3/8"-16
9.	GD6460	2	Rear Window, 6 1/2" x 10 1/2"
10.	GD6461-01	2	Rear Window Molding
11.	GD6487	1	Front Window, 10 1/2" x 19 1/4"
12.	GD6461-02	1	Front Window Molding
13.	G10017	4	Hex Head Cap Screw, 1/2"-13 x 1 1/2"
	G10228	4	Lock Washer, 1/2"
	G10216	4	Washer, 1/2" USS
	G10102	4	Hex Nut, 1/2"-13
14.	G10003	4	Hex Head Cap Screw, 3/8"-16 x 1 1/2"
	G10210	4	Washer, 3/8" USS
	G10229	4	Lock Washer, 3/8"
	G10101	4	Hex Nut, 3/8"-16
15.	GD6978	1	Rubber Stop
16.	GA4664	1	Adjustable Bracket

GRAIN TANK PANELS

840/1040

WTP004/WTP008

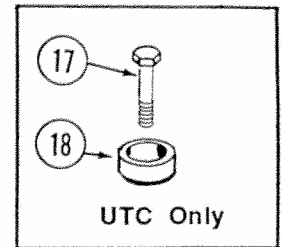
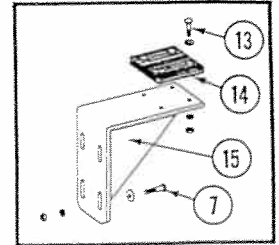
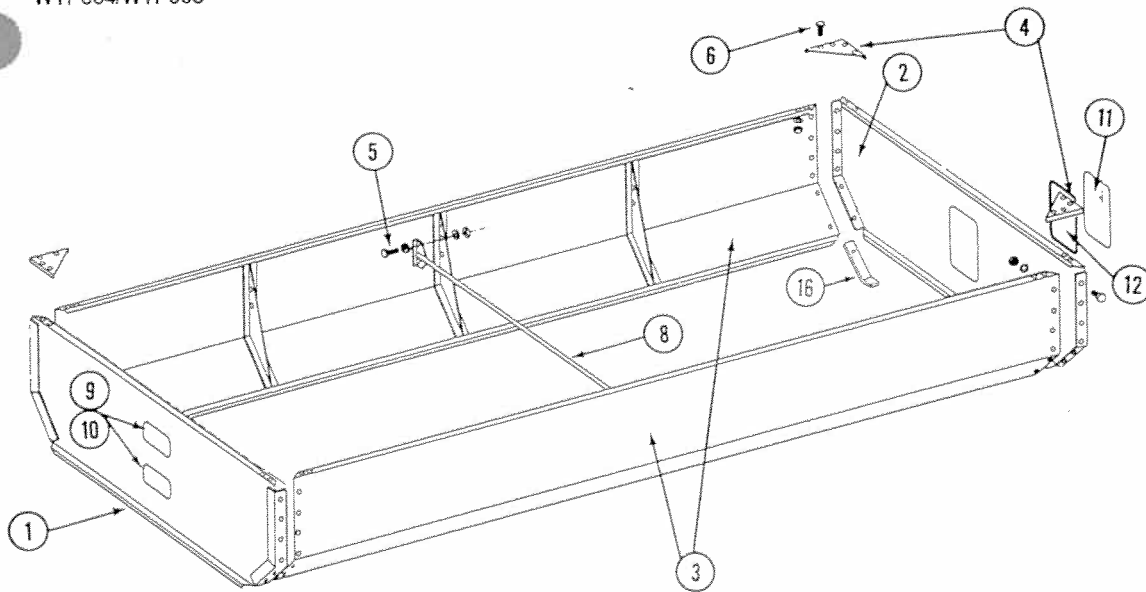

ITEM	PART NO.	QTY.	DESCRIPTION
1.	GA4194	1	Rear Panel, 37 3/8" x 120 1/2", 840
	GA5779	-	Rear Panel, 49 7/8" x 132 1/2", 1040
2.	GA5772	1	Front Panel, 37 3/8" x 120 1/2", 840
	GA5780	-	Front Panel, 49 7/8" x 132 1/2", 1040
3.	GA4196	2	Side Panel, 37 3/8" x 239 1/2", 840
	GA5776	-	Side Panel, 49 7/8" x 239 1/2", 1040
4.	GD0327	4	Corner Cap
5.	G10017	-	Hex Head Cap Screw, 1/2"-13 x 1 1/2"
	G10228	-	Lock Washer, 1/2"
	G10102	-	Hex Nut, 1/2"-13
6.	G10001	16	Hex Head Cap Screw, 3/8"-16 x 1"
	G10229	16	Lock Washer, 3/8"
	G10101	16	Hex Nut, 3/8"-16
7.	G10017	4	Hex Head Cap Screw, 1/2"-13 x 1 1/2"
	G10228	4	Lock Washer, 1/2"
	G10216	4	Washer, 1/2" USS
	G10102	4	Hex Nut, 1/2"-13
8.	GA0437	3	Cross Brace, 119 1/2", 840
	GA5778	4	Cross Brace, 131 1/2", 1040
9.	GD6460	2	Rear Window, 6 1/2" x 10 1/2"
10.	GD6461-01	2	Rear Window Molding
11.	GD6487	1	Front Window, 10 1/2" x 19 1/4"
12.	GD6461-02	1	Front Window Molding
13.	G10003	4	Hex Head Cap Screw, 3/8"-16 x 1 1/2"
	G10210	4	Washer, 3/8" USS
	G10229	4	Lock Washer, 3/8"
	G10101	4	Hex-Nut, 3/8"-16
14.	GD6978	1	Rubber Stop
15.	GA4664	1	Adjustable Bracket
16.	GD4173	-	Corner Patch, 2 1/2" x 7 1/2", Wheel, Scale and Sof-Trak Wagons
	GD8225	-	Corner Patch, 2 1/2" x 10", Row Crop Wagons
17.	G10028	4	Hex Head Cap Screw, 3/4"-10 x 3" (Secures Grain Wagon To Utility Tracked Chassis)
	G10231	4	Lock Washer, 3/4"
	G10105	4	Hex Nut, 3/4"-10
18.	GD9602-02	4	Sleeve (Between Grain Wagon And Utility Tracked Chassis)

AXLE

640/840 WHEEL WAGON

HTA038

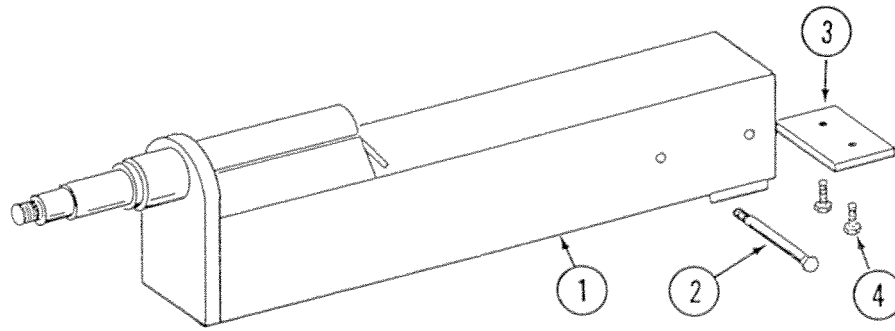

ITEM	PART NO.	QTY. Per Wagon	DESCRIPTION
1.	GA5734	2	Stub Axle
2.	G10540	2	Hex Head Cap Screw, 1"-8 x 12"
	G10118	2	Lock Washer, 1"
	G10117	2	Hex Nut, 1"-8
3.	GD7538	2	Shim
4.	G10014	4	Hex Head Cap Screw, 1/2"-13 x 1"
	G10228	4	Lock Washer, 1/2"

AXLE

640/840 WHEEL SCALE WAGON

HTA030

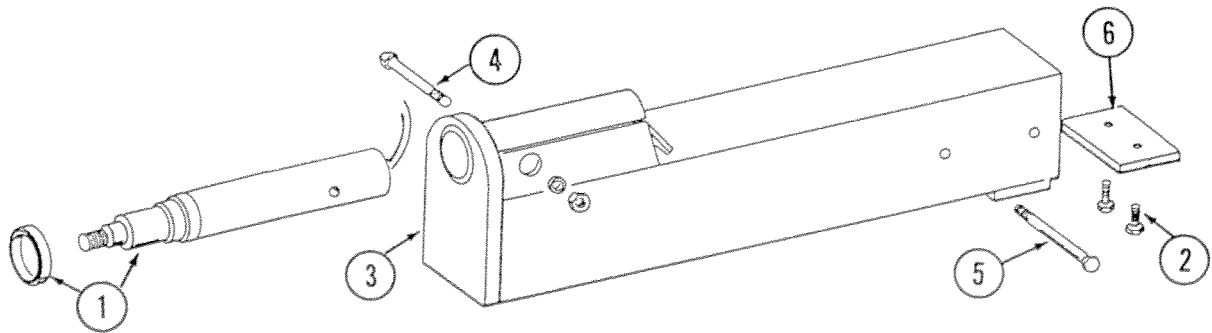

ITEM	PART NO.	QTY. Per Wagon	DESCRIPTION
1.	GA4687	2	Weigh Axle W/Spacer, 4 1/2"
	GD6996	-	Spacer
2.	G10014	4	Hex Head Cap Screw, 1/2"-13 x 1"
	G10228	4	Lock Washer, 1/2"
3.	GA5736	1	Stub Axle, R.H.
	GA5737	1	Stub Axle, L.H.
4.	G10011	2	Hex Head Cap Screw, 5/8"-11 x 5 1/2"
	G10107	2	Lock Nut, 5/8"-11
5.	G10540	2	Hex Head Cap Screw, 1"-8 x 12"
	G10118	2	Lock Washer, 1"
	G10117	2	Hex Nut, 1"-8
6.	GD7538	2	Shim

AXLE

840/1040 ROW CROP WAGON

HTA037

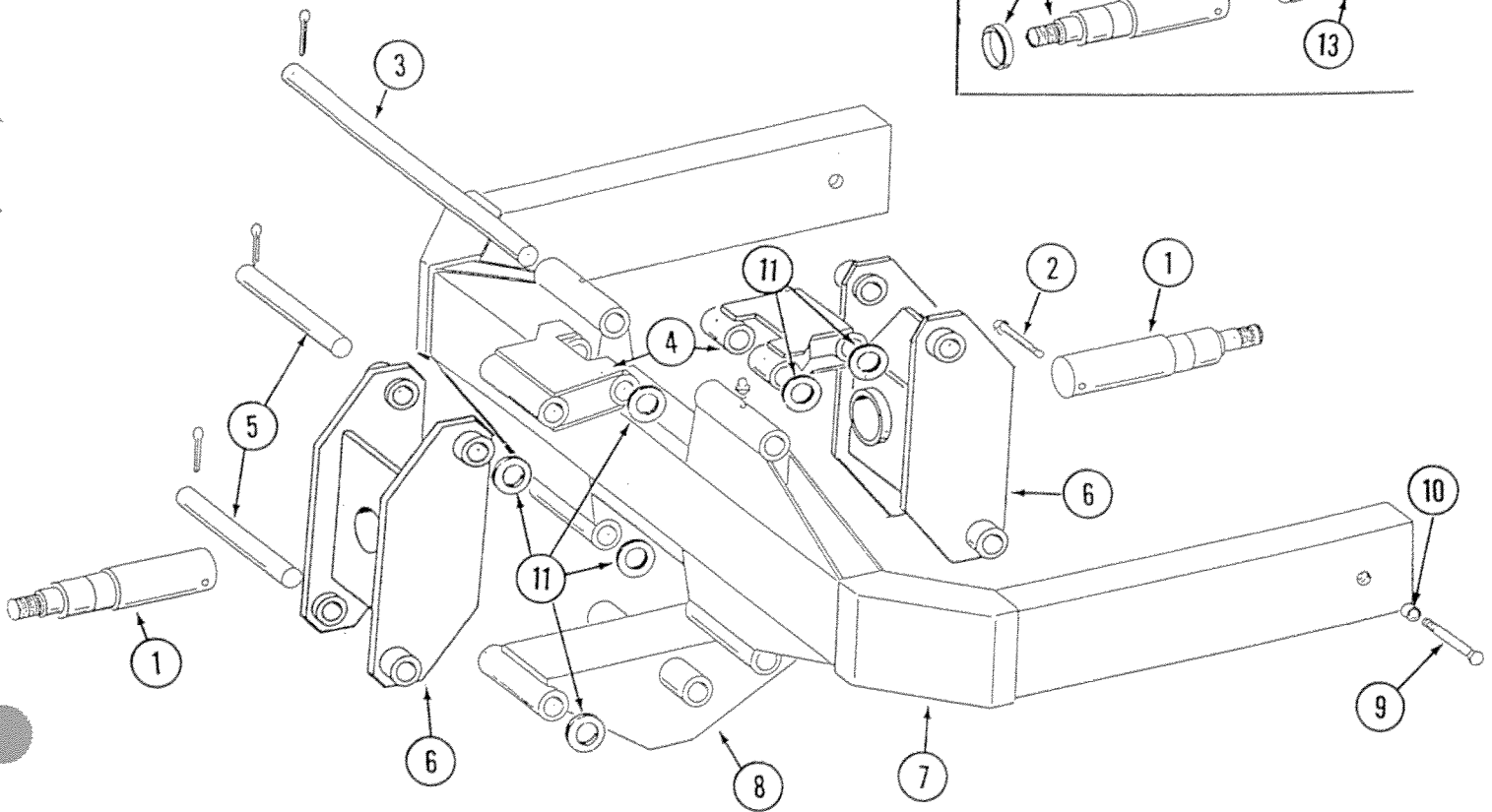

ITEM	PART NO.	QTY.	DESCRIPTION
		Per Wagon	
1.	GD8037	4	Spindle, 4 1/2"
2.	G10400	4	Hex Head Cap Screw, 3/4"-10 x 6 1/2"
	G10112	4	Lock Nut, 3/4"-10
3.	GD8140	2	Pin, 2 1/8" x 36 1/2"
	G10461	4	Cotter Pin, 3/8" x 3"
4.	GA5797	4	Top Link Arm W/Grease Fittings
	G10641	-	Grease Fitting, 1/8" NPT
5.	GD8119	8	Pin, 2 1/8" x 16 1/4"
	G10461	16	Cotter Pin, 3/8" x 3"
6.	GA5790	4	Link Plate W/Grease Fittings (SN 2433 - 499999/SN 500292 & On)
	GA6042	-	Link Plate W/Grease Fittings (SN 500000 - 500291)
	G10641	-	Grease Fitting, 1/8" NPT
7.	GA5806	2	Extension Axle W/Grease Fittings
	G10641	-	Grease Fitting, 1/8" NPT
8.	GA5789	2	Bottom Link Arm W/Grease Fittings
	G10640	-	Grease Fitting, 1/4"-28
9.	G10402	4	Hex Head Cap Screw, 1"-8 x 8"
	G10396	4	Lock Nut, 1"-8
10.	GD7585-02	-	Sleeve, 1 1/4" (Where Applicable)
	GD7585-06	-	Sleeve, 1 3/4" (Where Applicable)
11.	G10234	-	Machine Bushing, 10 Gauge (As Required)
	G10336	-	Machine Bushing, 16 Gauge (As Required)
12.	GA6752	-	Weigh Axle W/Spacer, 4 1/2"; Scale Wagon
	GD6996	-	Spacer
13.	GD9594	-	Sleeve, 8 7/16", Scale Wagon

AXLE

640/840 SOF-TRAK WAGON

HTA033/HTA036

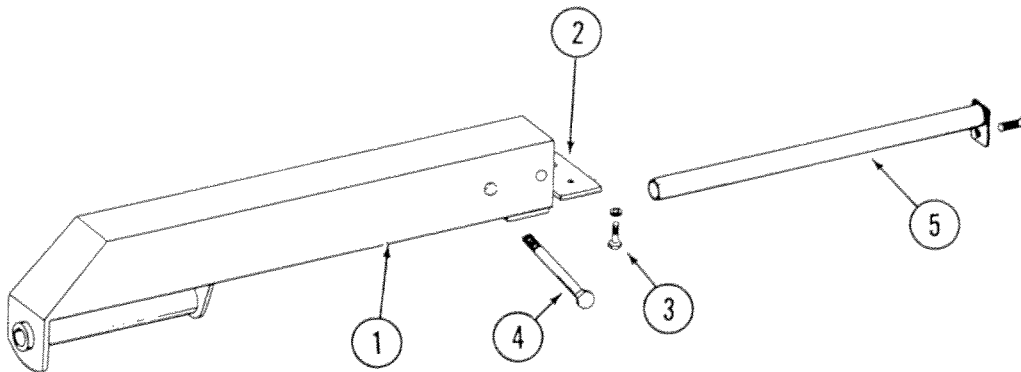

ITEM	PART NO.	QTY. Per Wagon	DESCRIPTION
1.	GA5489	2	Stub Axle W/Grease Fittings
	G10641	-	Grease Fitting, 1/8" NPT
2.	GD7538	2	Shim, 5" x 8"
3.	G10014	4	Hex Head Cap Screw, 1/2"-13 x 1"
	G10228	4	Lock Washer, 1/2"
4.	G10540	2	Hex Head Cap Screw, 1"-8 x 12"
	G10118	2	Lock Washer, 1"
	G10117	2	Hex Nut, 1"-8
5.		-	See "Track And Carriage"

TRACK AND CARRIAGE

640/840 SOF-TRAK WAGON

HTA033

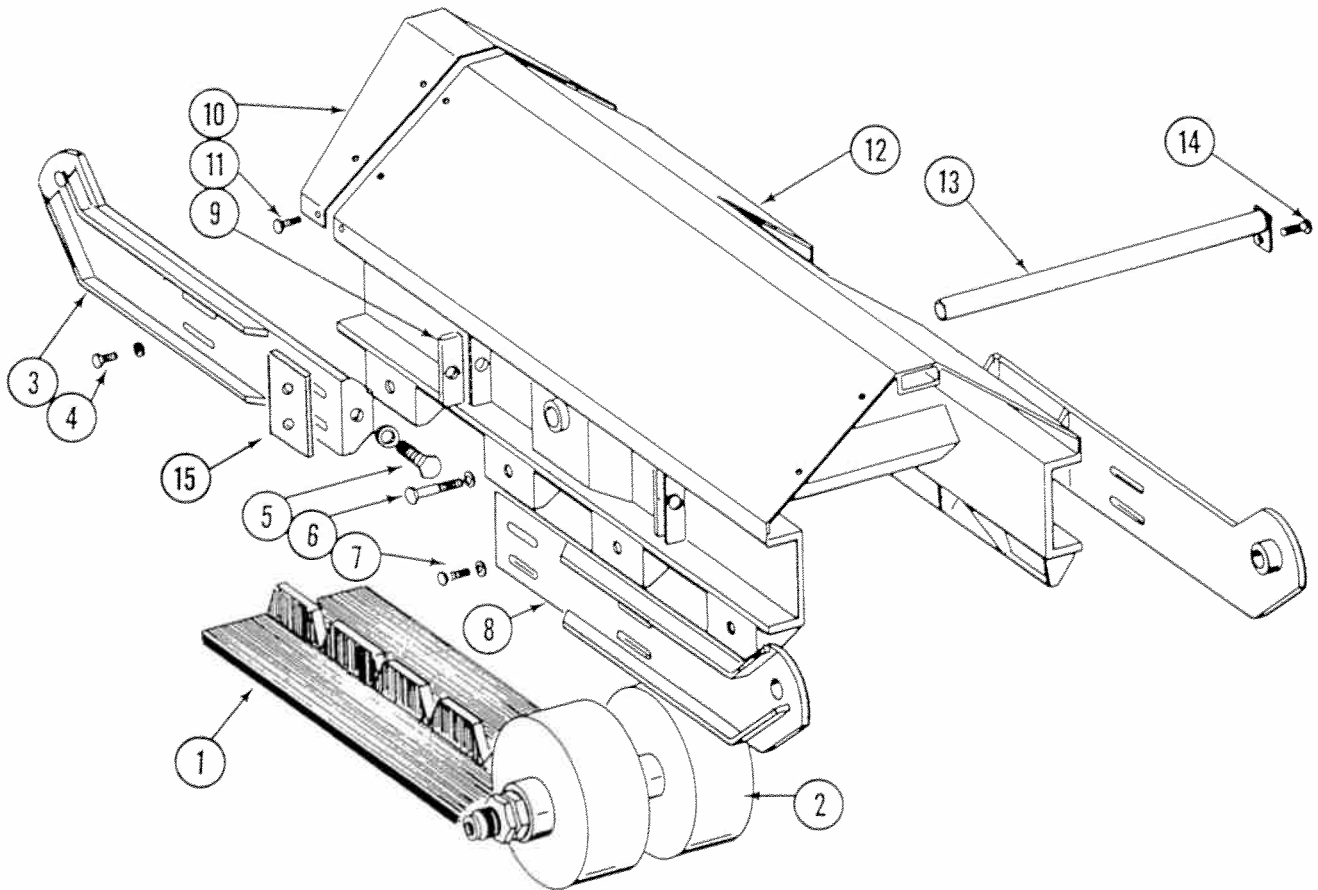

ITEM	PART NO.	QTY.		DESCRIPTION
		Per	Assy.	
1.	GD7096	1		Rubber Track
2.		-		See "Midwheel, Sof-Trak"
3.	GA5477	2		Sidebar, L.H. (SN Prior To 600377 Order A5477 And A5476)*
4.	G10537	8		Hex Head Cap Screw, 3/4"-16 x 2 1/2"
	G10218	-		Washer, 3/4" USS (Sub D8279 Plate)
	G10231	8		Lock Washer, 3/4"
	G10327	8		Hex Nut, 3/4"-16
5.	G10539	4		Hex Head Adjusting Bolt, 1"-14 x 7"
	G10082	4		Washer, 1" SAE
6.		4		See "Midwheel, Sof-Trak"
7.	G10611	8		Hex Head Cap Screw, 3/4"-16 x 5"
	G10218	8		Washer, 3/4" USS (Sub D8279 Plate)
	G10231	8		Lock Washer, 3/4"
	G10327	8		Hex Nut, 3/4"-16
8.	GA5476	2		Sidebar, R.H. (SN Prior To 600377 Order A5477 And A5476)*
9.	GD8860	4		Tap Block
10.	GD7521	2		Mud Scraper
11.	G10014	12		Hex Head Cap Screw, 1/2"-13 x 1"
	G10216	12		Washer, 1/2" USS
	G10228	12		Lock Washer, 1/2"
	G10102	12		Hex Nut, 1/2"-13
12.		-		Track and Carriage (Non-Stock Item)
13.	GA5514	1		Pin
14.	G10005	1		Hex Head Cap Screw, 5/8"-11 x 1 3/4"
15.	GD8279	8		Plate, 2" x 4 1/2"

* NOTE: Specifications changed at SN 600377.

HUB AND TIRE ASSEMBLY

WHEEL, SCALE AND ROW CROP WAGONS

HTA002/HTA004/HTA039

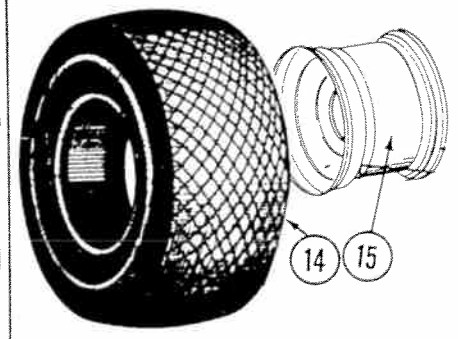
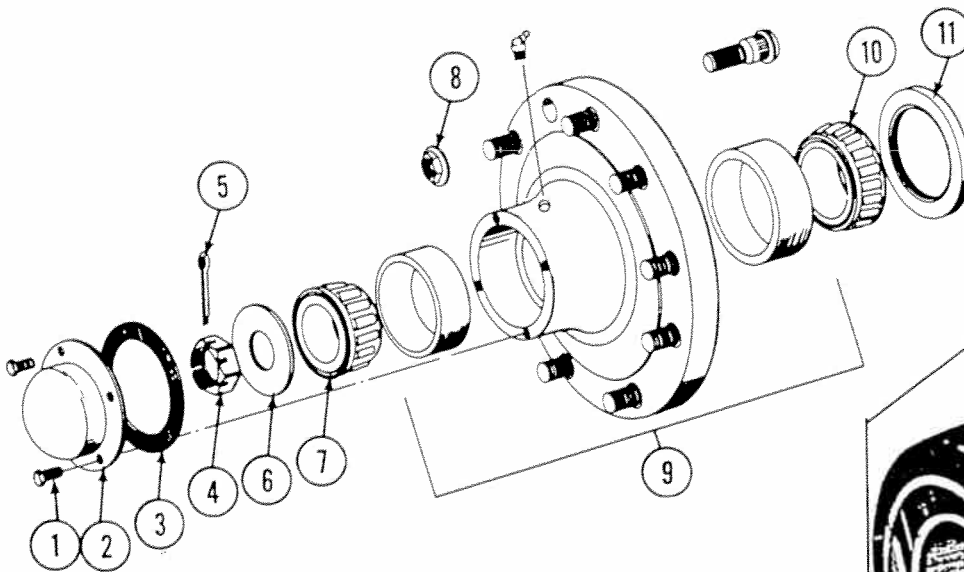

Wheel and Scale Wagons

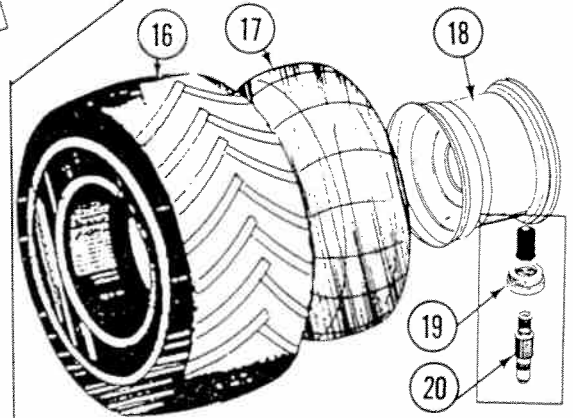

Row Crop Wagons

ITEM	PART NO.	QTY. Per Assy.	DESCRIPTION
1.	G10054	4	Hex Head Cap Screw, 5/16"-18 x 1/2"
2.	GD1360	1	Cap
3.	GD1359	1	Seal
4.	G10726	1	Slotted Hex Nut, 2"-12
5.	G10471	1	Cotter Pin, 3/8" x 2 1/2"
6.	G10198	1	Washer, 2"
7.	GA0530	1	Outer Bearing
8.	G10625	10	Flange Nut, 3/4"-16
9.	GA0529	1	Hub W/Cups, Grease Fitting and Stud Bolts (10 Bolt)
	GR0192	-	Outer Cup
	GR0191	-	Inner Cup
	G10373	-	Grease Fitting, 1/8"-27 45°
	GR0257	-	Stud Bolt, 3/4"-16 x 2 1/2"
10.	GA0531	1	Inner Bearing
11.	GA0532	1	Seal
12.	GA6128	-	Valve Stem (Not Shown)
13.	GA5447	-	Brass Plug (Not Shown)
14.	GD4093	-	Tire, 24.5" x 32" R-3 Diamond-Type Tread, 12 Ply, 640 (Used W/A0446 Wheel)
	GD8495	-	Tire, 24.5" x 32" R-1 Traction-Type Tread, 12 Ply, 640 (Used W/A0446 Wheel)
	GD4092	-	Tire, 30.5" x 32" R-3 Diamond-Type Tread, 12 Ply, 640/840 (Used W/A0445 Wheel)
	GD8496	-	Tire, 30.5" x 32" R-1 Traction-Type Tread, 12 Ply, 640/840 (Used W/A0445 Wheel)
15.	GA0446	-	Wheel, 21" x 32", 640 (Used W/D4093 or D8495 Tire)
	GA0445	-	Wheel, 27" x 32", 640/840 (Used W/D4092 or D8496 Tire)
16.	GD7995	-	Tire, 18.4" x 38" R-1 Traction-Type Tread, 10 Ply
17.	GD8068	-	Tube, 18.4" x 38"
18.	GA5768	-	Wheel, 38" x WH16A
19.	GD1528	1	Nylon Nut
20.	GD1527	1	Valve Stem (Includes Core and Cap)

MIDWHEEL

SOF-TRAK WAGON

HTA035

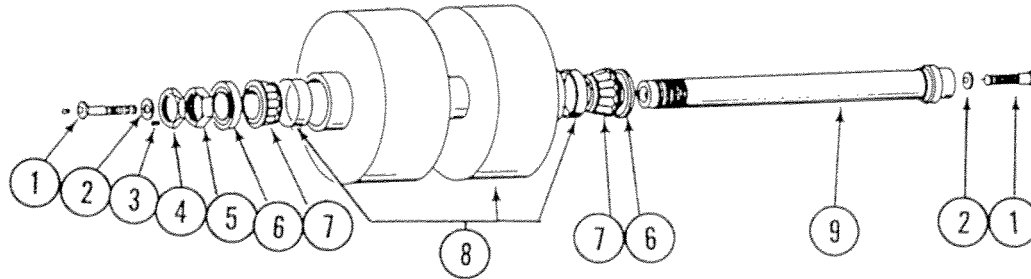

ITEM	PART NO.	QTY.		DESCRIPTION
		Per	Assy.	
1.	GA5487	2		Bolt W/Grease Fitting, 1 1/4" x 3 1/2", Grade 8
	G10641	-		Grease Fitting, 1/8" NPT
2.	G10236	2		Lock Washer, 1 1/4"
3.	G10535	1		Set Screw, 3/8"-16 x 3/4"
4.	GD7460	1		Jam Nut, 2 1/2"-12
5.	GD7451	1		Stepped Nut, 2 1/2"-12
6.	GD7452	2		Seal
7.	GA0779	2		Bearing
8.	GA5486	1		Midwheel W/Cups
	GR0323	-		Cup
9.	GA4999	1		Spindle

ENDWHEEL

SOF-TRAK WAGON

HTA034

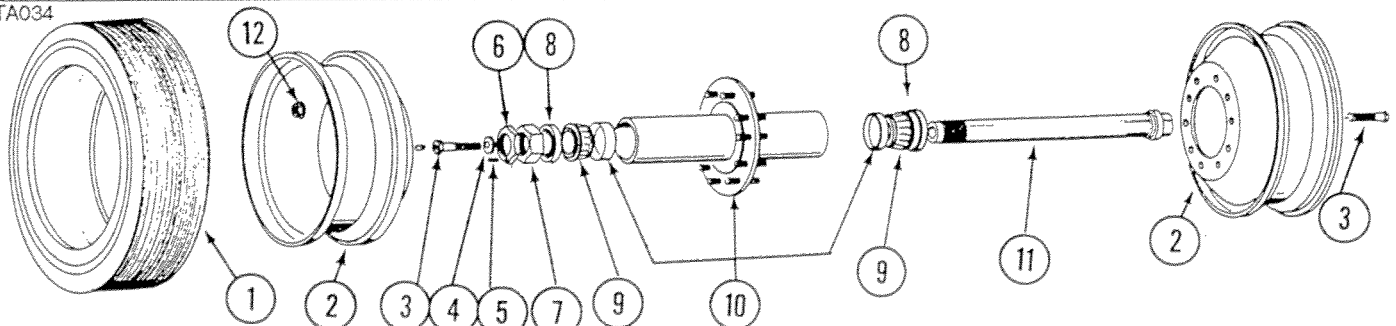

ITEM	PART NO.	QTY.		DESCRIPTION
		Per	Assy.	
1.	GD7640	2		Tire, 8.25" x 20" , Smooth
	GA5574	-		Tube W/Insert, Use With D7640
	GD9307	-		Tire, 8.25" x 20", Treaded Truck
	GD9308	-		Tube, Use With D9307
2.	GA5490	2		Rim
3.	GA5487	2		Bolt W/Grease Fitting, 1 1/4" x 3 1/2", Grade 8
	G10641	1		Grease Fitting, 1/8" NPT
4.	G10236	2		Lock Washer, 1 1/4"
5.	G10535	1		Set Screw, 3/8"-16 x 3/4"
6.	GD7460	1		Jam Nut, 2 1/2"-12
7.	GD7451	1		Stepped Nut, 2 1/2"-12
8.	GD7452	2		Seal
9.	GA0779	2		Bearing
10.	GA5484	1		Hub W/Cups and Bolts
	GR0323	-		Cup
	GD7489	-		Bolt (10 Bolt Hub), Threaded Both Ends
	GR0257	-		Bolt (20 Bolt Hub)
11.	GA4999	1		Spindle
12.	GR0256	20		Flange Nut, 3/4"-16

HITCH CAP/PLATE

WAC004/WAC012/WAC013

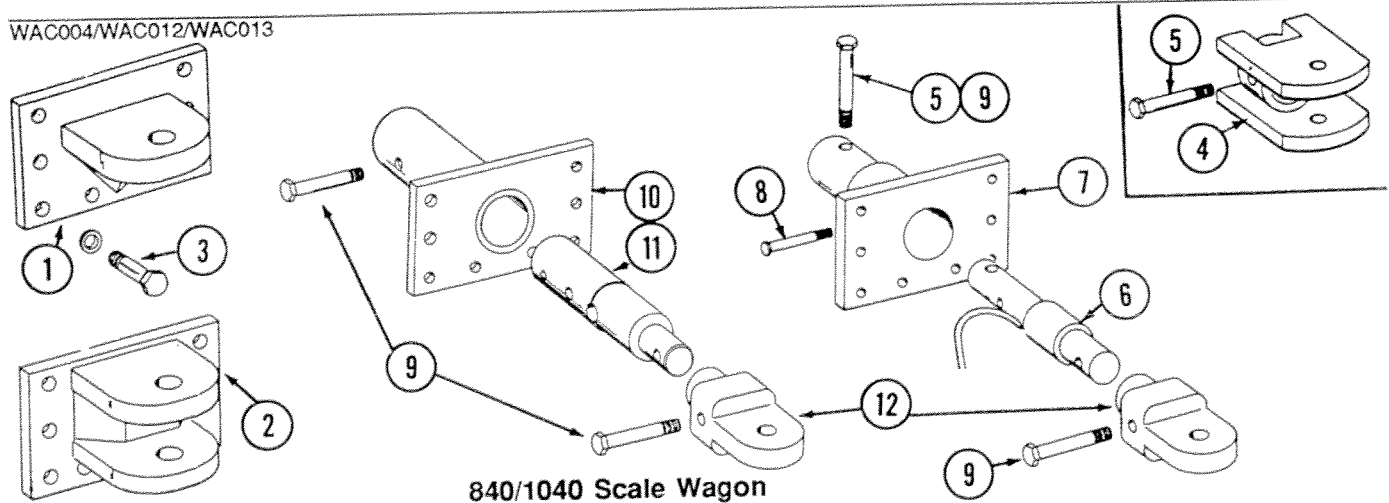

840/1040 Scale Wagon

640 Scale Wagon

ITEM	PART NO.	QTY.	DESCRIPTION
1.	GA4206	-	Hitch Cap, Single Clevis
2.	GA4214	-	Hitch Cap, Double Clevis
3.	G10441	8	Hex Head Cap Screw, 7/8"-9 x 3", Grade 8
	G10330	8	Lock Washer, 7/8"
	G10442	8	Hex Nut, 7/8"-9
4.	GA4677	-	Double Clevis, 640 Scale Wagon
5.	G10263	-	Hex Head Cap Screw, 1"-8 x 5"
	G10396	-	Lock Nut, 1"-8
6.	GA4681	-	Weigh Beam, 2 1/2", 640 Scale Wagon
7.	GA4680	-	Hitch Plate, 640 Scale Wagon
8.	G10050	-	Hex Head Cap Screw, 3/4"-10 x 5"
	G10112	-	Lock Nut, 3/4"-10
9.	G10648	-	Hex Head Cap Screw, 1"-8 x 6", Grade 8
	G10647	-	Hex Nut, 1"-8, Grade 8
10.	GA6022	-	Hitch Plate, 840/1040 Scale Wagon
11.	GA6025	-	Weigh Beam, 3 3/4", 840/1040 Scale Wagon
12.	GA6521	-	Single Clevis, 640/840/1040 Scale Wagon

OPTIONAL SAFETY CHAIN

WAC011

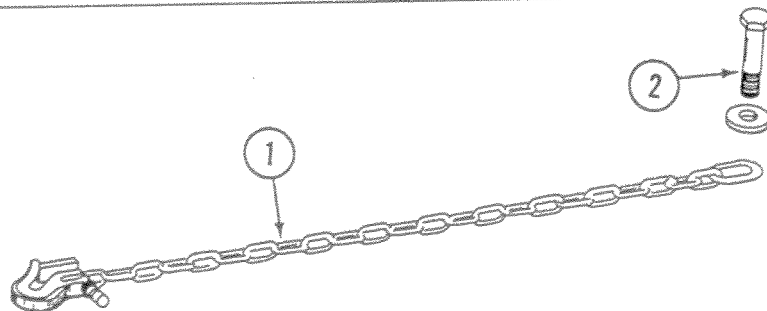

ITEM	PART NO.	QTY.	DESCRIPTION
1.	GA4774	1	Safety Chain
2.	G10238	1	Hex Head Cap Screw, 1 1/4"-7 x 4"
	G10139	1	Washer, 1 1/4" USS
	G10236	1	Lock Washer, 1 1/4"
	G10239	1	Hex Nut, 1 1/4"-7

VERTICAL AUGER FOLD CYLINDER

640/840/1040

CYL032

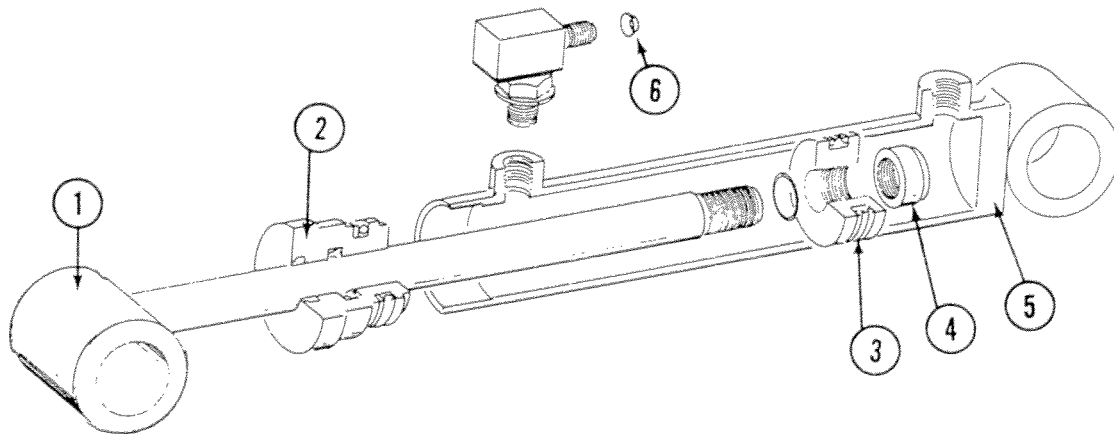

ITEM	PART NO.	QTY.	DESCRIPTION
1.	GA4193	1	Rod
2.	GD5954	1	Gland
3.	GD4525	1	Piston
4.	GR0964	1	Special Jam Nut
5.	GA4192	1	Barrel
6.	GD6323	1	Restrictor
A.	GA4115	-	Cylinder Complete, 2 1/2" x 20 1/16" (Less Restrictor)
B.	GR0963	-	Seal Kit, Includes: (1) T Seal, (2) O-Ring, (1) BU Ring, (1) U-Cup, (1) Wiper

GRAIN FLOW CONTROL GATE CYLINDER

640

CYL030/CYL049

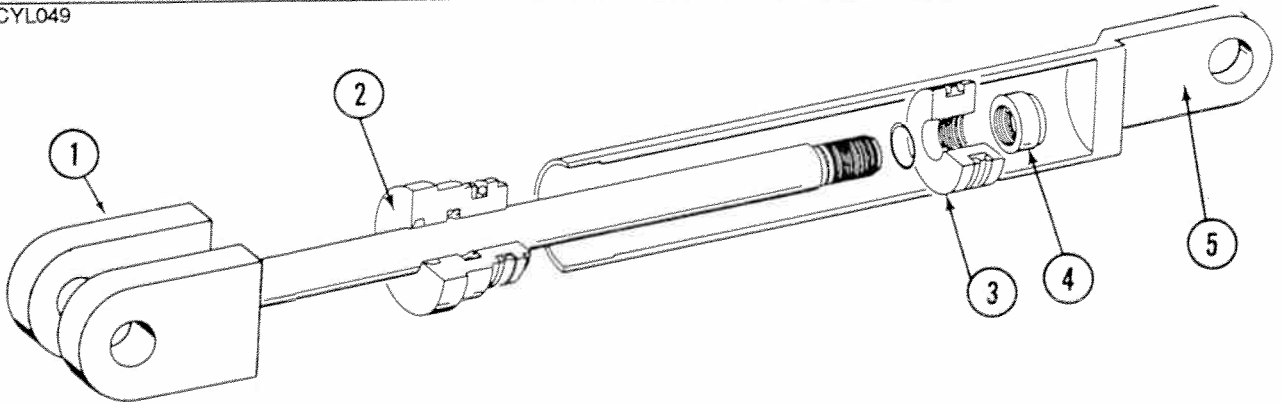

ITEM	PART NO.	QTY.	DESCRIPTION
1.	GA4188	1	Rod
2.	GD5949	1	Gland
3.	GD4632	1	Piston
4.	GR0959	1	Lock Nut, 3/4"-16
5.	GA4187	1	Barrel
A.	GA4129	-	Cylinder Complete, 2" x 8"
B.	GR0927	-	Seal Kit, Includes: (1) T Seal, (2) O-Rings, (1) BU Ring, (1) U-Cup, (1) Wiper

GRAIN FLOW CONTROL GATE CYLINDER

840/1040

CYL044

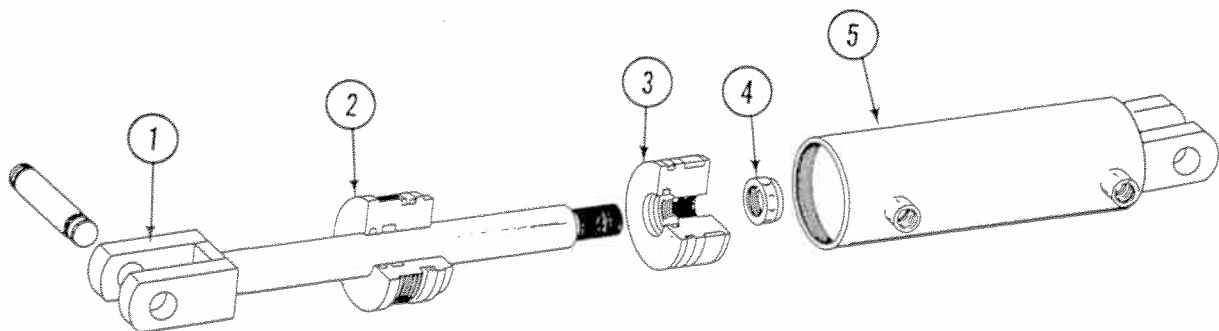

ITEM	PART NO.	QTY.	DESCRIPTION
1.	GA4757	1	Rod
2.	GD5954	1	Gland
3.	GD5956	1	Piston
4.	GR0986	1	Thin Nut, 1"-14
5.	GA4756	1	Barrel
A.	GA4255	-	Cylinder Complete, 2 1/2" x 10"
B.	GR0930	-	Seal Kit, Includes: (1) Wear Ring, (1) T Seal, (2) O-Rings, (1) U-Cup, (1) BU Ring, (1) Wiper

WAC002/WAC003

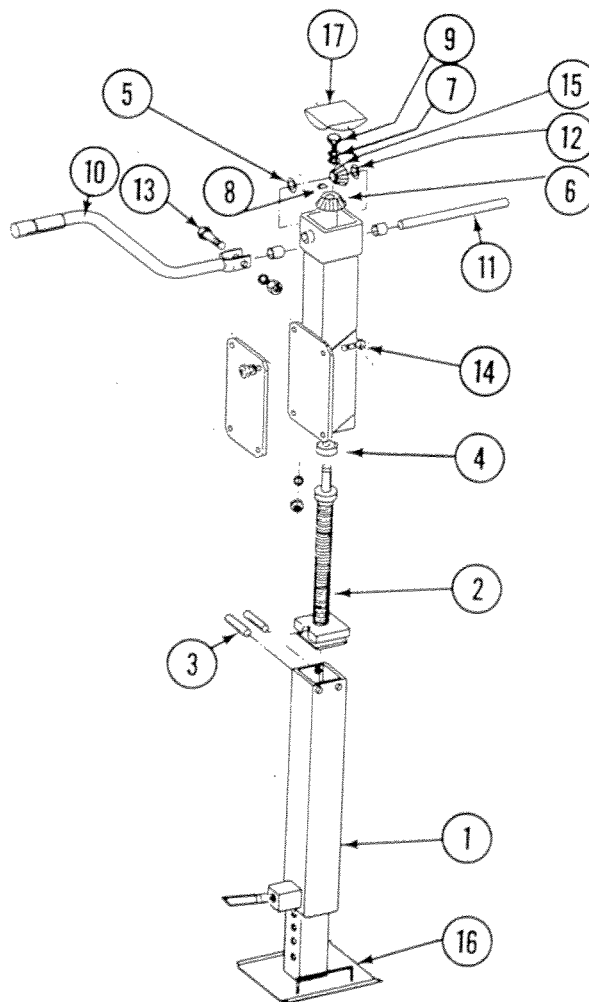

ITEM	PART NO.	QTY.	DESCRIPTION
1.	GR1009	1	Secondary W/Lock Assembly
2.	GR0974	1	Nut and Screw Assembly
3.	GR0976	2	Pin
4.	GR0691	1	Bearing
5.	GR0692	3	Machine Washer, 1" x 2" x 18 Gauge
6.	GR0693	1	Gear, 18 Tooth
7.	GR0702	2	Retaining Washer, 1/2"
8.	GR0694	2	Key
9.	GR0703	1	Retaining Hex Head Cap Screw
10.	GD1350	1	Handle
11.	GR0977	1	Shaft
12.	GR0704	1	Snap Ring
13.	G10049	1	Hex Head Cap Screw, 3/8"-16 x 2 1/2"
	G10210	2	Washer, 3/8" USS
	G10108	1	Lock Nut, 3/8"-16
14.	G10005	4	Hex Head Cap Screw, 5/8"-11 x 1 3/4"
	G10230	4	Lock Washer, 5/8"
	G10104	4	Hex Nut, 5/8"-11
15.	GR0698	1	Gear, 12 Tooth
16.	GR1008	1	Drop Tube
17.	GR0700	1	Lid
A.	G1K168	-	Jack Replacement Kit

JACK ASSEMBLY

840/1040

WAC003

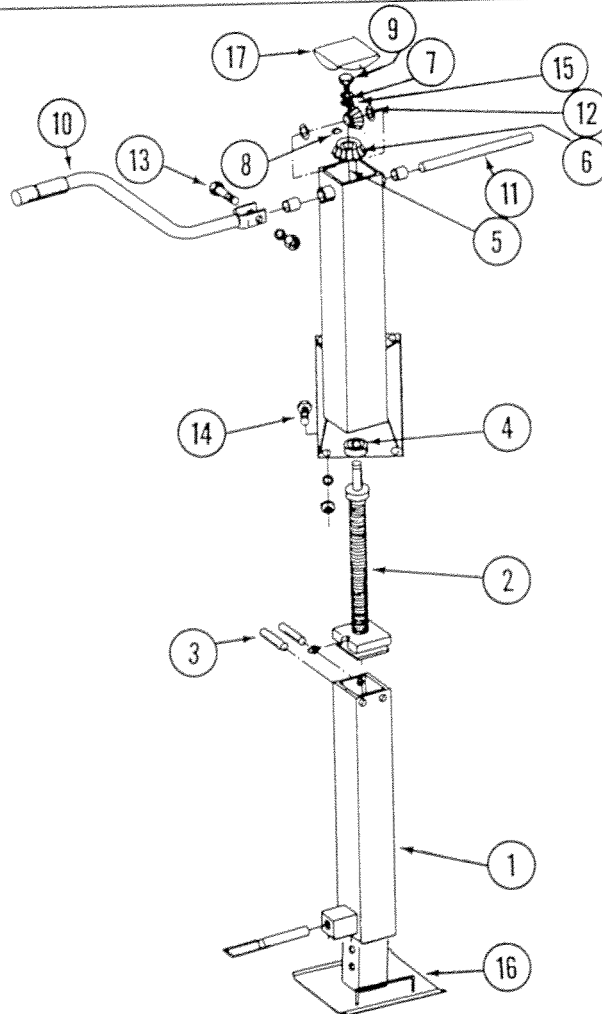

ITEM	PART NO.	QTY.	DESCRIPTION
1.	GR1011	1	Secondary W/Lock Assembly
2.	GR0689	1	Nut and Screw Assembly
3.	GR0690	2	Pin
4.	GR0691	1	Bearing
5.	GR0692	3	Machine Washer, 1" x 2" x 18 Gauge
6.	GR0693	1	Gear, 18 Tooth
7.	GR0702	2	Retaining Washer, 1/2"
8.	GR0694	2	Key
9.	GR0703	1	Retaining Hex Head Cap Screw
10.	GD1350	1	Handle
11.	GR0696	1	Shaft
12.	GR0704	1	Snap Ring
13.	G10049	1	Hex Head Cap Screw, 3/8"-16 x 2 1/2"
	G10210	2	Washer, 3/8" USS
	G10108	1	Lock Nut, 3/8"-16
14.	G10005	4	Hex Head Cap Screw, 5/8"-11 x 1 3/4"
	G10230	4	Lock Washer, 5/8"
	G10104	4	Hex Nut, 5/8"-11
15.	GR0698	1	Gear, 12 Tooth
16.	GR1010	1	Drop Tube
17.	GR0700	1	Lid
A.	GR0449	-	Jack Replacement Kit

ELECTRONIC SCALE COMPONENTS

ECP014/WAC012/HTA030/WAC013

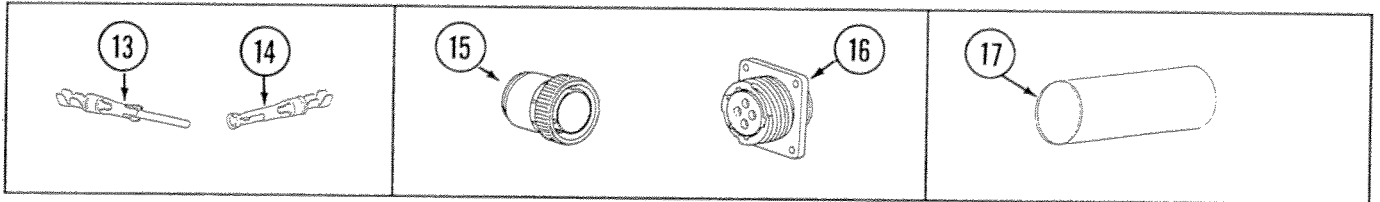
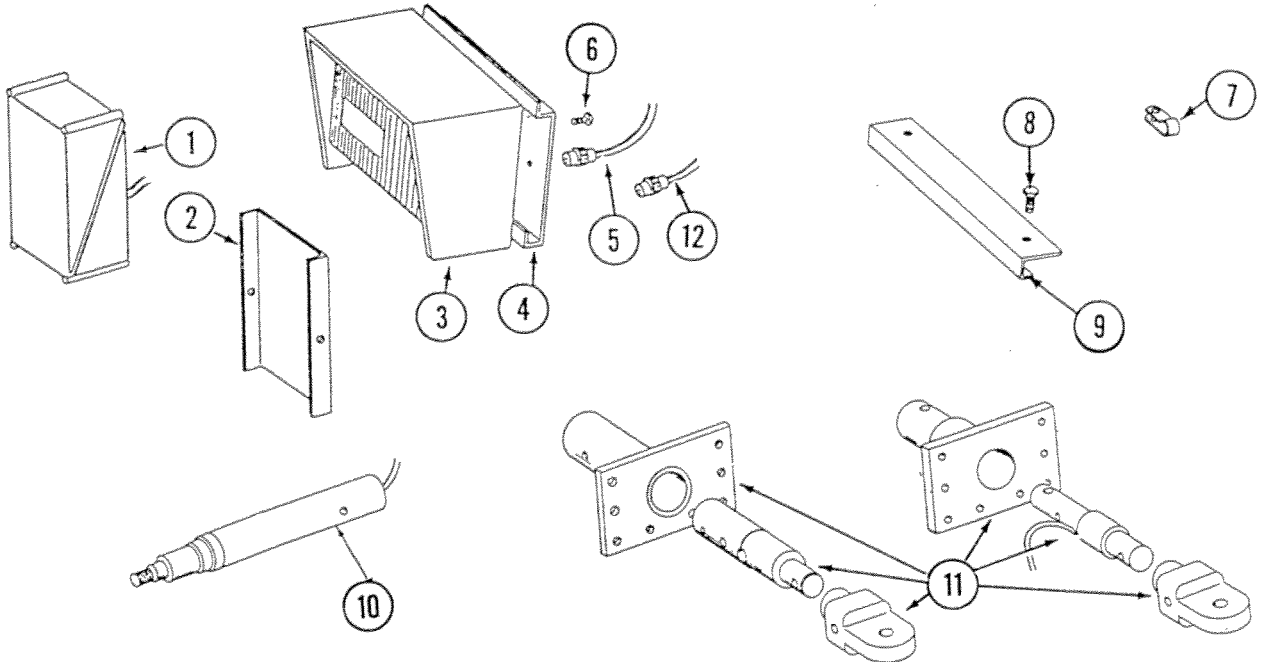

ITEM	PART NO.	QTY.	DESCRIPTION
1.	GA5692	1	Junction Box W/ Cable
2.	GD7008	1	Cover
3.	GA6717	1	Indicator, EZ150, 640 Wheel Wagon
	GA6718	-	Indicator, EZ150, 840 Wheel Wagon
	GA6753	-	Indicator, EZ150, 840/1040 Row Crop Wagon
	GR1175	-	Plastic Housing (Not Shown)
4.	GD7826	1	Mounting Bracket
5.	GA4683	1	Cable Extension (To Junction Box Cable)
6.	G10023	-	Hex Head Cap Screw, 1/4"-20 x 3/4"
	G10110	-	Lock Nut, 1/4"-20
7.	GD6291	-	Insulated Clamp
8.	G10522	-	Screw, 1/4"-14 x 3/4"
9.	GD7138	-	Cover, 28"
	GD7139	-	Cover, 20"
10.		-	See "Axle, 640/840 Scale Wheel Wagon" or "Axle, 840/1040 Row Crop Wagon"
11.		-	See "Hitch Cap/Plate"
12.	GA5663	1	Battery Power Cable, 640/840 Wheel Wagon
	GA6772	-	Battery Power Cable, 840/1040 Row Crop Wagon
13.	GR1067	-	Pin
14.	GR1171	-	Female Socket Contact
15.	GR1068	-	Connector, Male
16.	GR1170	-	Connector, Female
17.	GR1069	-	Shrink Tube, 2 1/2"

LIGHT PACKAGE

ECP010

Serial No. 2433 - 500376

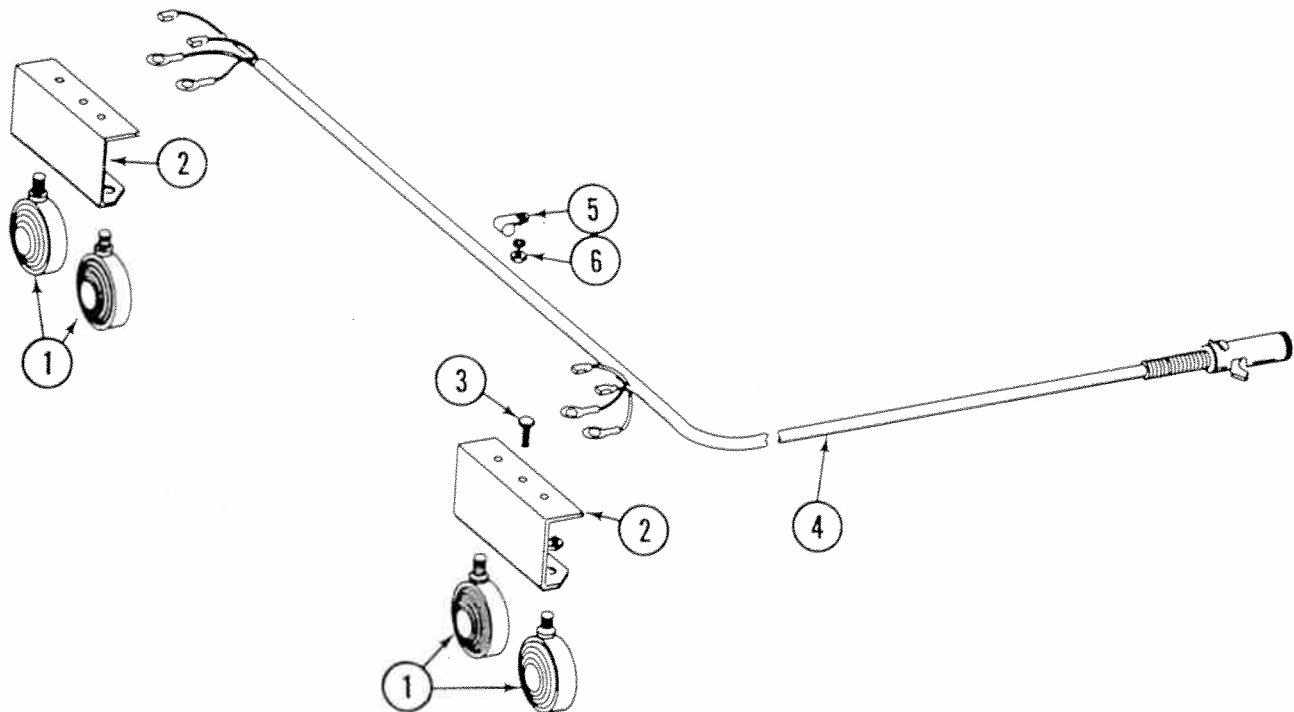

ITEM	PART NO.	QTY.	DESCRIPTION
1.	GA4122	2	Single Red Light Assembly Complete W/Female Terminal
	GA4123	2	Double Amber Light Assembly Complete W/Male Terminal
	GR0968	-	Bulb, No. 1156
	GR0970	-	Red Lens
	GR0969	-	Amber Lens
	G10289	-	Hex Nut, 1/2"-20
	G10525	-	Star Washer, 1/2"
		-	Rubber Washer (Non-Stock Item)
	GR0971	-	O-Ring Gasket
	GR0972	-	Pigtail
	G10266	-	Female Terminal
	G10269	-	Male Terminal
	2.	GD6273	2
G10001		4	Hex Head Cap Screw, 3/8"-16 x 1"
3.	G10229	4	Lock Washer, 3/8"
	G10101	4	Hex Nut, 3/8"-16
4.	GA4121	1	Wiring Harness Assembly, 640
	GA4127	-	Wiring Harness Assembly, 840/1040
5.	GD6291	-	Clamp
6.	G10229	-	Lock Washer, 3/8"
	G10101	-	Hex Nut, 3/8"-16

LIGHT PACKAGE

ECP010/WAC017

Serial No. 500377 & On

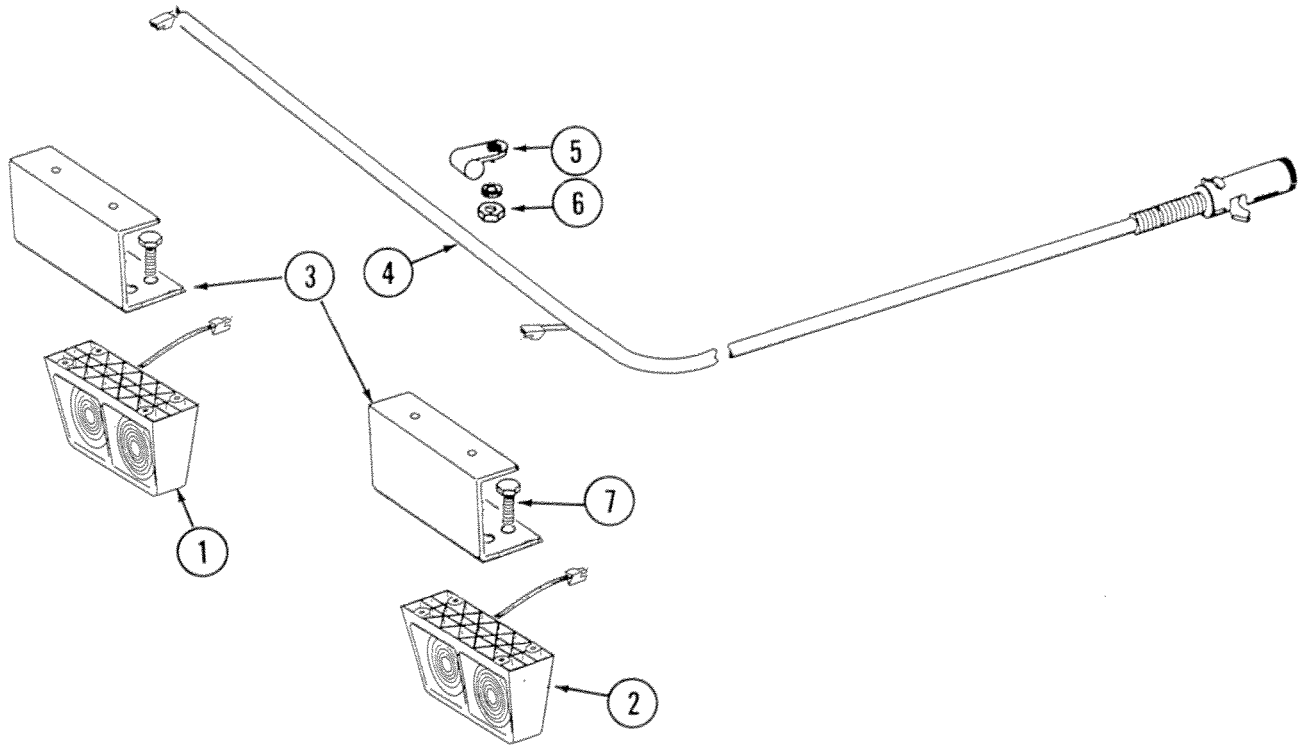

ITEM	PART NO.	QTY.	DESCRIPTION
1.	GA6699	1	Double Light Assembly, L.H.
	GR1203	-	Red Lens
	GR1204	-	Amber Lens
	GR1205	-	Cover
	GR1206	-	Rubber Grommet (4)
	GR1207	-	Lamp Unit
	GR1208	-	Bulb
2.	GA6700	1	Double Light Assembly, R.H.
	GR1203	-	Red Lens
	GR1204	-	Amber Lens
	GR1205	-	Cover
	GR1206	-	Rubber Grommet (4)
	GR1207	-	Lamp Unit
	GR1208	-	Bulb
3.	GD9425	2	Mount
4.	GA6703	1	Wiring Harness Assembly, 640
	GA6697	-	Wiring Harness Assembly, 840/1040
5.	GD6291	-	Clamp
6.	G10229	-	Lock Washer, 3/8"
	G10101	-	Hex Nut, 3/8"-16
7.	G10064	8	Hex Head Cap Screw, 1/4"-20 x 1"
	G10110	8	Lock Nut, 1/4"-20
A.	G1K156	-	Light Package, Includes Light Assemblies, Mounts, Wiring Harness, Clamps, Tie Straps And Hardware

DECALS, REFLECTORS AND TIE STRAPS

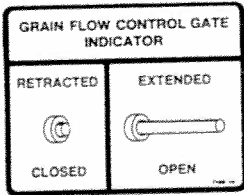

1



2

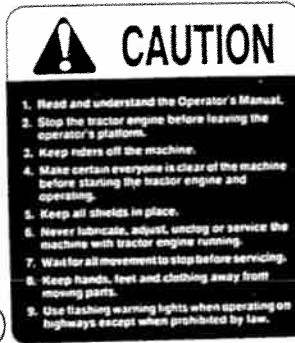

3

KINZE

4



5



6

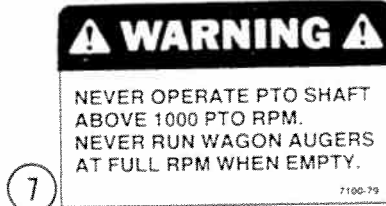

7



9

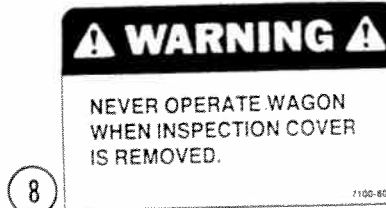

8

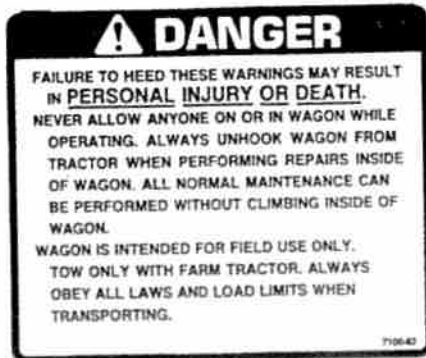

10

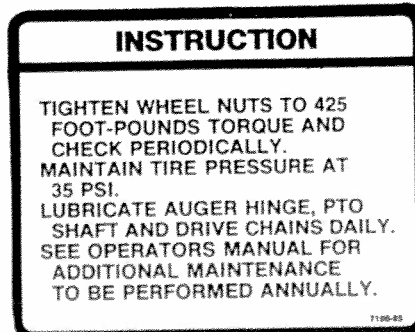

11



12



13

15 **640**

16 **840**



DECALS, REFLECTORS AND TIE STRAPS



WEEKLY

18



DAILY

19



20



21



22



23

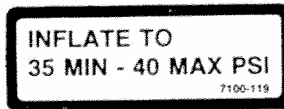

24

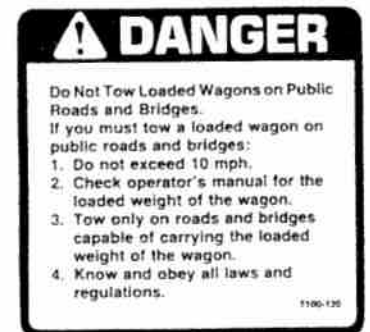

25

Electronic Scale

26

Sof-Trak

27



28

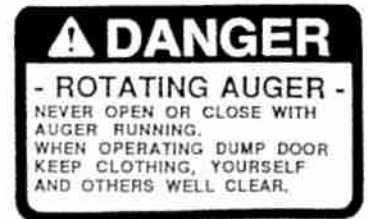

29

Row Crop

30

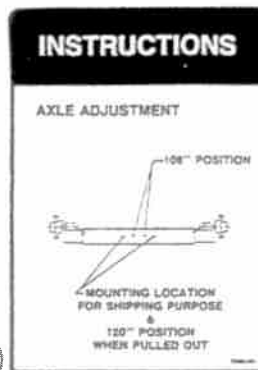

31

1040

32

DECALS, REFLECTORS AND TIE STRAPS

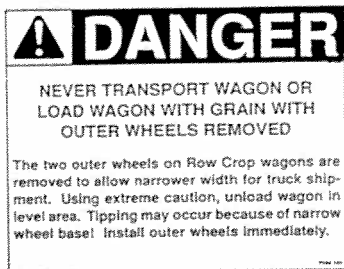

33



34

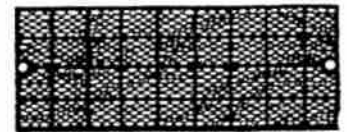

35



36

ITEM	PART NO.	QTY.	DESCRIPTION
1.	G7100-19	1	Decal, Grain Flow Indicator
2.	G7100-36	1	SMV Emblem
3.	G7100-46	1	Decal, Caution
4.	G7100-54	2	Decal, KINZE
5.	G7100-56	1	Decal, Warning
6.	G7100-67	1	Decal, Danger
7.	G7100-79	1	Decal, Warning
8.	G7100-80	2	Decal, Warning
9.	G7100-81	1	Decal, Danger
10.	G7100-82	1	Decal, Danger
11.	G7100-85	1	Decal, Instructions
12.	G7100-86	1	Decal, Danger
13.	G7100-90	1	Decal, Warning
14.	G7100-93	-	White Striping, 3" x 100 Yards (Not Shown)
	GR1172-01	-	White Striping, Per Foot (Not Shown)
15.	G7100-105	2	Decal, 640
16.	G7100-106	2	Decal, 840
17.	G7100-107	2	Decal, KINZE Logo
18.	G7100-110	-	Decal, Grease
19.	G7100-111	-	Decal, Oil
20.	G7100-112	1	Decal, Caution
21.	G7100-113	1	Decal, Caution
22.	G7100-117	1	Decal, Danger
23.	G7100-118	1	Decal, Caution
24.	G7100-119	2	Decal, Instructions
25.	G7100-120	1	Decal, Danger
26.	G7100-130	2	Decal, Electronic Scale
27.	G7100-131	2	Decal, Sof-Trak
28.	G7100-134	1	Decal, Danger
29.	G7100-142	1	Decal, Danger
30.	G7100-150	2	Decal, Row Crop
31.	G7100-151	1	Decal, Instructions
32.	G7100-152	2	Decal, 1040
33.	G7100-161	1	Decal, Danger
34.	G7100-162	2	Decal, Danger, Row Crop
35.	G7200-03	4	Reflector, Red
	G7200-04	2	Reflector, Amber
36.	GD1512	-	Tie Strap, 6"
	GD2117	-	Tie Strap, 14 1/2"
37.	GR0155	-	Blue Paint, Aerosol (Not Shown)
	GR0439	-	Blue Paint, Quart (Not Shown)
	GR0440	-	Blue Paint, Gallon (Not Shown)

NUMERICAL INDEX

Part No.	Page	Part No.	Page	Part No.	Page
G1K156	P42a	G10011	P9, P13, P17, P30	G10132	P23
G1K168	P39	G10013	P8, P11, P15, P19	G10133	P2, P3, P4, P5
G306-06	P25	G10014	P30, P32, P33	G10134	P2, P3, P4, P5
G2700-06-06	P25	G10016	P13	G10135	P7
G3301-47	P21	G10017	P11, P13, P19, P21	G10139	P36
G3301-65	P17		P23, P25, P28, P29	G10141	P15
G3304-51	P19	G10018	P6	G10142	P6, P7
G3304-63	P15	G10019	P11, P13, P15, P19	G10143	P6
G5503-02-02	P23	G10023	P41	G10185	P22, P23
G6801-06-08	P11, P25	G10025	P8, P9, P13, P27	G10198	P34
G6801-08	P13, P27	G10028	P19, P21, P29	G10210	P28, P29, P39, P40
G7100-19	P45	G10033	P22	G10215	P15, P17, P19, P21
G7100-36	P45	G10036	P21, P22, P23	G10216	P13, P27, P28, P29, P33
G7100-46	P45	G10037	P7	G10217	P15
G7100-54	P45	G10039	P15, P22	G10218	P11, P15, P17, P19,
G7100-56	P45	G10049	P4b, P5b, P39, P40		P21, P33
G7100-67	P45	G10050	P36	G10219	P11, P13
G7100-79	P45	G10054	P34	G10228	P7, P11, P13, P15,
G7100-80	P45	G10055	P17, P19		P17, P19, P21, P22,
G7100-81	P45	G10058	P15, P17, P19		P23, P25, P28, P29,
G7100-82	P45	G10064	P42a		P30, P32, P33
G7100-85	P45	G10072	P22	G10229	P11, P13, P23, P25,
G7100-86	P45	G10080	P8, P9, P15, P17,		P27, P28, P29,
G7100-90	P45		P19, P21, P23		P42, P42a
G7100-93	P45	G10082	P33	G10230	P11, P13, P15, P17,
G7100-105	P45	G10087	P11, P13		P19, P21, P23, P39, P40
G7100-106	P45	G10101	P11, P13, P23, P25	G10231	P8, P9, P13, P17,
G7100-107	P45		P27, P28, P29, P42, P42a		P21, P27, P29, P33
G7100-110	P45	G10102	P11, P13, P19, P21,	G10232	P11, P13, P15, P17
G7100-111	P45		P22, P23, P25, P27,	G10233	P21
G7100-112	P45		P28, P29, P33	G10234	P8, P31
G7100-113	P45	G10104	P11, P13, P15, P17,	G10236	P35, P36
G7100-117	P45		P19, P21, P23, P39, P40	G10238	P36
G7100-118	P45	G10105	P13, P27, P29, P11	G10239	P36
G7100-119	P45	G10106	P13	G10263	P36
G7100-120	P45	G10107	P8, P9, P11, P13,	G10266	P42
G7100-130	P45		P15, P17, P19, P21,	G10269	P42
G7100-131	P45		P22, P23, P30	G10289	P42
G7100-134	P45	G10108	P2a, P3a, P4a, P4b,	G10318	P23
G7100-142	P45		P5a, P5b, P8, P9,	G10326	P4b, P5b
G7100-150	P45		P25, P27, P39, P40	G10327	P33
G7100-151	P45	G10109	P2, P3, P4, P5	G10330	P36
G7100-152	P45	G10110	P41, P42a	G10336	P31
G7100-161	P45	G10111	P22, P25	G10359	P9
G7100-162	P45	G10112	P15, P17, P19, P21,	G10360	P9
G7200-03	P45		P31, P36	G10373	P34
G7200-04	P45	G10115	P11, P22	G10396	P31, P36
G10001	P2a, P3a, P4a, P5a, P8,	G10116	P13	G10400	P21, P31
	P9, P23, P25, P27,	G10117	P30, P32	G10402	P31
	P28, P29, P42	G10118	P30, P32	G10423	P15, P19, P21, P22
G10003	P28, P29	G10121	P6	G10426	P11, P13
G10004	P15, P17, P19, P21, P27	G10122	P7	G10434	P11, P13
G10005	P19, P33, P39, P40	G10123	P7	G10438	P15, P17, P19, P21
G10007	P11, P13	G10124	P7	G10441	P36
G10008	P11, P15, P17	G10125	P11, P13, P22, P23	G10442	P36
G10009	P21	G10127	P13	G10443	P21

NUMERICAL INDEX

Part No.	Page	Part No.	Page	Part No.	Page
G10456	P2, P2a, P3, P3a, P4, P4a, P5, P5a	GA1014	P13	GA4539	P13
G10460	P8, P9, P11, P13	GA1015	P13	GA4664	P28, P29
G10461	P31	GA1016	P27	GA4677	P36
G10471	P34	GA1017	P27	GA4680	P36
G10522	P41	GA1111	P11, P25	GA4681	P36
G10525	P42	GA1112	P11	GA4683	P41
G10526	P15, P17, P21	GA1137	P25	GA4687	P30
G10535	P35	GA1539	P27	GA4688	P28
G10537	P33	GA4085	P25	GA4690	P15, P17, P19, P21
G10539	P33	GA4088	P25	GA4691	P17
G10540	P30, P32	GA4108	P13	GA4692	P17
G10543	P17	GA4110	P11, P13	GA4697	P27
G10556	P2, P2a, P3, 3a	GA4112	P11, P13	GA4698	P27
G10563	P4, P4a, P5, P5a	GA4115	P37	GA4718	P27
G10610	P11, P13	GA4121	P42	GA4719	P27
G10611	P33	GA4122	P42	GA4734	P15
G10625	P34	GA4123	P42	GA4756	P38
G10640	P31	GA4127	P42	GA4757	P38
G10641	P8, P9, P11, P13, P15, P17, P19, P21, P22, P23, P31, P32, P35, P36	GA4129	P38	GA4774	P36
G10648	P36	GA4134	P25	GA4999	P35
G10700	P2, P2a, P3, P3a, P4, P4a, P4b, P5, P5a, P5b	GA4135	P25	GA5447	P34
G10726	P34	GA4147	P22	GA5476	P33
G10730	P15, P17, P19, P21	GA4151	P28	GA5477	P33
G10749	P7	GA4152	P28	GA5484	P35
GA0406	P6	GA4155	P28	GA5486	P35
GA0423	P13	GA4156	P28	GA5487	P35
GA0437	P29	GA4160	P11, P13	GA5489	P32
GA0445	P34	GA4163	P11	GA5490	P35
GA0446	P34	GA4168	P11	GA5514	P33
GA0447	P17, P21	GA4171	P19	GA5574	P35
GA0448	P9, P17	GA4174	P11, P13	GA5663	P41
GA0449	P8, P15, P19, P21, P23	GA4177	P19, P21	GA5692	P41
GA0450	P22	GA4178	P15, P17	GA5734	P30
GA0451	P11, P22	GA4179	P15	GA5736	P30
GA0452	P13	GA4180	P15, P17, P19, P21	GA5737	P30
GA0504	P11, P13, P22, P23	GA4182	P19, P21	GA5768	P34
GA0511	P13	GA4185	P25	GA5769	P13
GA0517	P23	GA4186	P25	GA5772	P29
GA0529	P34	GA4187	P38	GA5773	P13
GA0530	P34	GA4188	P38	GA5776	P29
GA0531	P19, P34	GA4189	P11	GA5778	P29
GA0532	P34	GA4192	P37	GA5779	P29
GA0593	P15, P17, P21	GA4193	P37	GA5780	P29
GA0624	P7	GA4194	P29	GA5789	P31
GA0685	P23	GA4196	P29	GA5790	P31
GA0686	P27	GA4206	P36	GA5797	P31
GA0696	P27	GA4208	P11	GA5806	P31
GA0699	P7	GA4214	P36	GA5813	P27
GA0713	P15	GA4255	P38	GA5852	P23
GA0714	P6	GA4532	P22	GA5857	P27
GA0715	P6	GA4533	P22	GA5858	P27
GA0779	P35	GA4534	P8	GA5859	P27
		GA4535	P11	GA5860	P27
		GA4536	P23	GA6022	P36
		GA4537	P23	GA6025	P36
		GA4538	P9	GA6042	P31

NUMERICAL INDEX

Part No.	Page	Part No.	Page	Part No.	Page
GA6128	P34	GD5949	P38	GD8221	P27
GA6521	P36	GD5954	P37, P38	GD8225	P29
GA6697	P42a	GD5956	P38	GD8279	P33
GA6699	P42a	GD6273	P42	GD8495	P34
GA6700	P42a	GD6279-04	P11, P13	GD8496	P34
GA6703	P42a	GD6291	P41, P42, P42a	GD8860	P33
GA6717	P41	GD6307	P25	GD9221	P21
GA6718	P41	GD6308	P25	GD9231	P17
GA6752	P31	GD6309	P25	GD9307	P35
GA6753	P41	GD6322	P25	GD9308	P35
GA6772	P41	GD6323	P37	GD9425	P42a
GD0144	P4, P4a, P4b, P5, P5a, P5b, P17, P21	GD6337	P15, P17, P19, P21	GD9594	P31
GD0147	P2, P2a, P3, P3a, P15	GD6387	P15	GD9602-02	P29
GD0148	P15, P19	GD6388	P8	GR0155	P45
GD0327	P28, P29	GD6392	P19	GR0190	P6
GD0653	P9	GD6408	P15	GR0191	P34
GD1346	P19, P21	GD6417	P11	GR0192	P34
GD1347	P23	GD6420	P8	GR0193	P25, P27
GD1350	P39, P40	GD6425-01	P15, P19, P21	GR0197	P15, P19
GD1357	P17, P21	GD6433	P8, P9	GR0198	P17, P21
GD1358	P17	GD6447	P25	GR0202	P15, P19
GD1359	P34	GD6460	P28, P29	GR0206	P17, P21
GD1360	P34	GD6461-01	P28, P29	GR0237	P4, P5
GD1435	P21	GD6461-02	P28, P29	GR0238	P4, P4a, P5, P5a
GD1447	P22	GD6462	P8, P9	GR0239	P4, P4a, P5, P5a
GD1512	P45	GD6487	P28, P29	GR0240	P4, P4a, P5, P5a
GD1527	P34	GD6885	P17	GR0241	P4, P4a, P5, P5a
GD1528	P34	GD6978	P28, P29	GR0242	P4, P4a, P5, P5a
GD2117	P45	GD6985	P25	GR0245	P4
GD2161	P8	GD6996	P30, P31	GR0248	P4, P5
GD2456	P8, P9	GD7008	P41	GR0249	P4, P5
GD2951	P21	GD7069	P9	GR0250	P5
GD3457-04	P15	GD7071	P27	GR0251	P4, P5
GD3457-06	P8	GD7096	P33	GR0252	P2, P3, P4, P5
GD4010	P22, P23	GD7138	P41	GR0253	P4
GD4012	P13	GD7139	P41	GR0254	P2a, P4, P4a
GD4014	P11, P13	GD7451	P35	GR0256	P35
GD4016	P21	GD7452	P35	GR0257	P34, P35
GD4061	P27	GD7460	P35	GR0258	P17
GD4077	P17, P21	GD7489	P35	GR0259	P17, P21
GD4079	P17, P21	GD7521	P33	GR0264	P9, P17
GD4086	P11, P13, P25, P27	GD7538	P30, P32	GR0265	P8, P15, P19, P21, P23
GD4092	P34	GD7585-02	P31	GR0266	P22
GD4093	P34	GD7585-06	P31	GR0289	P5
GD4108	P11, P13	GD7640	P35	GR0290	P5
GD4117	P15	GD7826	P41	GR0291	P7
GD4118	P15, P19	GD7995	P34	GR0292	P7
GD4119	P15, P19	GD8017	P9	GR0293	P7
GD4120	P19	GD8037	P31	GR0294	P7
GD4121	P15	GD8038-02	P9	GR0295	P7
GD4123	P19, P21	GD8038-03	P17	GR0296	P7
GD4173	P29	GD8038-04	P9	GR0297	P7
GD4525	P37	GD8068	P34	GR0298	P7
GD4632	P38	GD8119	P31	GR0299	P7
GD5892	P11	GD8140	P31	GR0300	P7
		GD8219	P23	GR0301	P7

NUMERICAL INDEX

Part No.	Page	Part No.	Page	Part No.	Page
GR0302	P6, P7	GR0963	P37	GR1230	P2a, P3a, P4a, P5a
GR0303	P7	GR0964	P37	GR1231	P4a, P5a
GR0304	P7	GR0965	P11	GR1232	P5a
GR0305	P7	GR0966	P8	GR1233	P5a
GR0306	P6, P7	GR0967	P11	GR1234	P2a, P3a
GR0307	P7	GR0968	P42	GR1235	P2a, P3a
GR0323	P35, P35	GR0969	P42	GR1236	P2a
GR0327	P6	GR0970	P42	GR1237	P2a, P3a
GR0328	P6	GR0971	P42	GR1238	P2a
GR0329	P6	GR0972	P42	GR1239	P3a
GR0330	P6	GR0974	P39	GR1240	P3a
GR0331	P6	GR0976	P39	GR1243	P3a, P5a
GR0332	P6	GR0977	P39	GR1245	P4b
GR0333	P6	GR0986	P38	GR1246	P5b
GR0334	P6	GR1008	P39	GR1247	P4a, P5a
GR0335	P6	GR1009	P39		
GR0336	P6	GR1010	P40		
GR0338	P6	GR1011	P40		
GR0339	P6	GR1060	P9		
GR0340	P6	GR1061	P13		
GR0341	P6	GR1067	P41		
GR0342	P2, P2a, P3, P3a	GR1068	P41		
GR0343	P2, P2a, P3, P3a	GR1069	P41		
GR0344	P2, P2a, P3, P3a	GR1170	P41		
GR0345	P2, P2a, P3, P3a	GR1171	P41		
GR0347	P2, P2a, P3, P3a	GR1172-01	P45		
GR0348	P2	GR1175	P41		
GR0349	P2, P3	GR1181	P4, P5		
GR0350	P2, P3	GR1182	P2, P3, P4, P5		
GR0351	P2, P3	GR1203	P42a		
GR0352	P2, P3	GR1204	P42a		
GR0353	P2	GR1205	P42a		
GR0354	P2	GR1206	P42a		
GR0355	P3	GR1207	P42a		
GR0356	P3	GR1208	P42a		
GR0361	P19	GR1209	P4b		
GR0439	P45	GR1210	P4b, P5b		
GR0440	P45	GR1211	P4b, P5b		
GR0449	P40	GR1212	P4b, P5b		
GR0689	P40	GR1213	P4b, P5b		
GR0690	P40	GR1214	P4b, P5b		
GR0691	P39, P40	GR1215	P4b, P5b		
GR0692	P39, P40	GR1216	P4b, P5b		
GR0693	P39, P40	GR1217	P4b, P5b		
GR0694	P39, P40	GR1218	P4b, P5b		
GR0696	P40	GR1219	P4b, P5b		
GR0698	P39, P40	GR1220	P4b, P5b		
GR0700	P39, P40	GR1221	P4b, P5b		
GR0702	P39, P40	GR1222	P4b, P5b		
GR0703	P39, P40	GR1223	P5b		
GR0704	P39, P40	GR1224	P4b, P5b		
GR0900	P3	GR1225	P4b		
GR0927	P38	GR1226	P5b		
GR0930	P38	GR1227	P4a		
GR0959	P38	GR1228	P4a, P5a		
GR0962	P25, P27	GR1229	P4a		