

MODEL 3650 and 3650 SDS TWIN-LINE® PLANTERS (EdgeVac® Seed Metering) OPERATOR & PARTS MANUAL

M0186

Rev. 12/07

This manual is applicable to: Model: 3650 And 3650 SDS Twin-Line® Planters
Serial Number: 655602 And On

Record the model number and serial number of your planter along with date purchased:

Model Number _____

Serial Number _____

Date Purchased _____

Monitor Serial Number _____
Measured Pulses Per Mile/Km (Radar Distance Sensor) _____
Measured Pulses Per Mile/Km (Magnetic Distance Sensor) _____

SERIAL NUMBER

The serial number plate is located on the planter frame to be readily available. It is suggested that your serial number and purchase date also be recorded above.

The serial number provides important information about your planter and may be required to obtain the correct replacement part. Always provide the model number and serial number to your KINZE® Dealer when ordering parts or anytime correspondence is made with KINZE Manufacturing, Inc.

D071803224

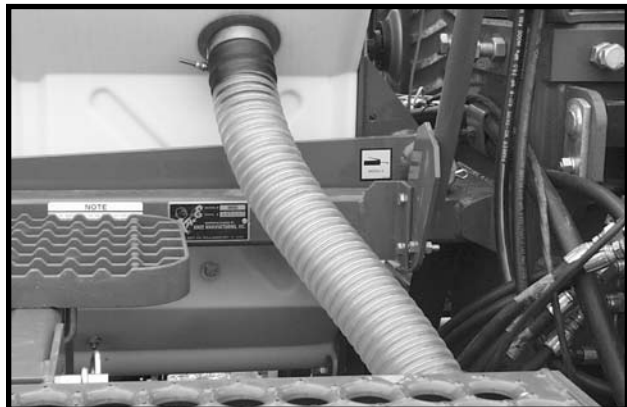

Model 3650 With SDS Seed Delivery System

D071603349



Model 3650 With Conventional Seed Hoppers

KINZE®, the KINZE® logo, Twin-Line®, Interplant® and EdgeVac® are trademarks of KINZE Manufacturing, Inc.

Rev. 12/07

PREDELIVERY/DELIVERY CHECKLIST

TO THE DEALER

Predelivery service includes assembly, lubrication, adjustment and test. This service helps to ensure that the planter will be delivered to the customer ready for field use.

PREDELIVERY CHECKLIST

After the planter has been completely assembled, use the following checklist and inspect the planter. Check off each item as it is found satisfactory or after proper adjustment is made.

- Recheck to be sure row units are properly spaced and optional attachments are correctly assembled.
- Be sure shipping stand has been removed.
- Be sure all grease fittings are in place and lubricated.
- Check planter and make sure all working parts are moving freely, bolts are tight and cotter pins are spread.
- Check all drive chains for proper tension and alignment.
- Check for oil leaks and proper hydraulic operation.
- Check to be sure hydraulic hoses are routed correctly to prevent damage.
- Inflate tires to specified PSI air pressure. Tighten wheel lug bolts and lug nuts to specified torques.
- Check to be sure all safety decals are correctly located and legible. Replace if damaged.
- Check to be sure all reflective decals and SMV sign are correctly located and visible when the planter is in transport position.
- Check to be sure safety/warning lights are installed correctly and working properly.
- Paint all parts scratched in shipment or assembly.
- Be sure all safety lockup devices are on the planter and correctly located.
- Auxiliary safety chain is properly installed and hardware is torqued to specification.
- Vacuum fan PTO-driven pump is attached correctly to the tractor. Oil reservoir is filled to capacity and system is inspected for leaks. (If Applicable)

This planter has been thoroughly checked and to the best of my knowledge is ready for delivery to the customer.

(Signature Of Set-Up Person/Dealer Name/Date)

OWNER REGISTER

Name _____ Delivery Date _____
Street Address _____ Model No. _____ Serial No. _____
City, State/Province _____ Dealer Name _____
ZIP/Postal Code _____ Dealer No. _____

DELIVERY CHECKLIST

At the time the planter is delivered, the following checklist is to be used as a reminder of very important information which should be conveyed to the customer. Check off each item as it is fully explained to the customer.

- Check for proper operation of vacuum fan and PTO driven pump (If Applicable) with tractor to be used with planter.
- Advise the customer that the life expectancy of this or any other machine is dependent on regular lubrication as directed in the Operator & Parts Manual.
- Tell the customer about all applicable safety precautions.
- Along with the customer, check to be sure the reflective decals and SMV sign are clearly visible with the planter in transport position and attached to the tractor. Check to be sure safety/warning lights are in working condition. Tell the customer to check federal, state/provincial and local regulations before towing or transporting on a road or highway.
- Give the Operator & Parts Manual to the customer and explain all operating adjustments.
- Read warranty to customer.
- Complete Warranty And Delivery Report form.

To the best of my knowledge this machine has been delivered ready for field use and customer has been fully informed as to proper care and operation.

(Signature Of Delivery Person/Dealer Name/Date)

AFTER DELIVERY CHECKLIST

The following is a list of items we suggest to check during the first season of use of the equipment.

- Check with the customer as to the performance of the planter.
- Check with the customer as to the performance of the EdgeVac® Seed Metering System.
- Review with the customer the importance of proper maintenance and adherence with all safety precautions.
- Check for parts that may need to be adjusted or replaced.
- Check to be sure all safety warning signs (decals), reflective decals and SMV sign are correctly located and that decals are legible. Replace if damaged or missing.
- Check to be sure safety/warning lights are working properly.

(Signature Of Follow-Up Person/Dealer Name/Date)

**RETURN THIS COMPLETED FORM TO KINZE® IMMEDIATELY along with Warranty And Delivery Report.
Retain photocopy of this form at dealership for After Delivery Check.**

Tear Along Perforation

TABLE OF CONTENTS

TO THE OWNER	1-1
WARRANTY	1-2
INTRODUCTION	2-1
SPECIFICATIONS	3-1
SAFETY PRECAUTIONS	4-1
SAFETY WARNING SIGNS	5-1
MACHINE OPERATION	
Analog Vacuum Gauge	6-12
Auxiliary Hydraulic Option.....	6-87
Auxiliary Work Lights Package.....	6-88
Checking Granular Chemical Application Rate.....	6-102
Checking Seed Population.....	6-101
Contact Wheel Spring Adjustment.....	6-7
Contact Wheel Drive Sprockets	6-9
Digital Vacuum Gauge Operation	6-12
Electronic Seed Monitor System	
KPM I.....	6-21
KPM II Stack-Mode	6-27
KPM III.....	6-55
Even-Row Push Row Unit Option.....	6-88
Fertilizer Openers And Attachments.....	6-90
Field Adjustments	
Seed Rate Transmission Adjustment.....	6-8
Field Operation	6-15
Field Test.....	6-100
Field To Transport Sequence	6-16
Hydraulic/Electric Operation	6-10
Initial Preparation Of The Planter.....	6-3
Leveling The Planter	6-6
Liquid Fertilizer Attachment	6-96
Liquid Fertilizer Rate Charts	6-98
Manual Safety Lockup	6-1
Metric Conversion Table.....	6-100
Point Row Clutches.....	6-85
Planting Speed	6-100
PTO Pump Drive And Oil Cooler Option.....	6-4
Rear Trailer Hitch	6-99
Ridge Planting	6-10
Row Marker Length Adjustment	6-19
Row Marker Operation.....	6-18
Row Marker Safety Lockup.....	6-1
Row Marker Speed Adjustment.....	6-19
Shear Protection.....	6-9
Tire Pressure	6-7
Tongue Safety Pin.....	6-2
Tractor Preparation And Hookup	6-5
Tractor Requirements	6-3

(Continued On Following Page)

TABLE OF CONTENTS

MACHINE OPERATION (Continued)

Transport Latch Locking Pin	6-2
Transport To Field Sequence	6-13
Transporting The Planter	6-100
Two-Speed Point Row Clutches.....	6-86
Vacuum Fan Motor Valve Block Assembly.....	6-12
Wrap Spring Wrench Operation.....	6-10

SEED METER OPERATION/MAINTENANCE

Field Adjustments

General Planting Rate Information	7-1
Planting And Application Rate Charts	7-7
Seed Meter Singulator Brush And Vacuum Level Adjustment	7-26
Seed Meter	7-2
Seed Meter Cleanout	7-5
Seed Meter Drive Release	7-28
Seed Meter Maintenance.....	7-29
Seed Metering System Troubleshooting	7-30
Vacuum Manifold Maintenance.....	7-29

SDS SEED DELIVERY SYSTEM OPERATION

Auger Speed Adjustment.....	8-4
Bulk Seed Hopper Covers	8-8
Bulk Seed Hopper Monitor.....	8-5
Capacities	8-1
Cleanout	8-8
Filling	8-6
Hydraulic System.....	8-3
Introduction.....	8-1
Operation	8-7
Overflow.....	8-2
Seed Distribution Manifold.....	8-2
Seed Lubrication.....	8-6
Seed Meter Mount Latch	8-3

ROW UNIT OPERATION

Closing Wheel Shield.....	9-2
Coulter Mounted Residue Wheels	9-11
Frame Mounted Coulter	9-6
Granular Chemical Bander Shield	9-12
Granular Chemical Banding Options	9-12
Granular Chemical Hopper And Drive	9-12
Interplant® Push Row Unit Clutch Sprockets	9-14
Interplant® Push Row Unit Lockups	9-13
Interplant® Push Row Unit Vacuum Hose Shutoff.....	9-14
Planting Depth	9-1
Quick Adjustable Down Force Springs	9-4
Residue Wheels (For Use With Frame Mounted Coulter).....	9-7
Row Unit Chain Routing	9-3
Row Unit Mounted Disc Furrower.....	9-7
Row Unit Mounted No Till Coulter.....	9-10
Row Unit Mounted Residue Wheel.....	9-8
Seed Hopper (Conventional Seed Hopper)	9-2
“V” Closing Wheel Adjustment (Rubber And Cast Iron).....	9-1

TABLE OF CONTENTS

LUBRICATION

Bulk Seed Hopper Elevator Chain	10-4
Bushings	10-3
Center Post	10-5
Drive Chains	10-1
Grease Fittings	10-6
Interplant® Push Row Unit Lockups	10-5
Liquid Fertilizer Piston Pump Crankcase Oil Level	10-6
Lubrication Symbols	10-1
Sealed Bearings	10-1
U-Joint Slides.....	10-5
Wheel Bearings	10-5
Wrap Spring Wrench Assembly	10-4

MAINTENANCE

15" Seed Opener Disc Blade/Bearing Assembly	11-6
Bulk Seed Hopper Elevator Chain Adjustment	11-12
Bulk Seed Hopper Monitor System Wiring Schematic.....	11-40
Chain Tension Adjustment	11-2
Check Valve (Located In Valve Block on Rear Center Frame)	11-17
Check Valve Inspection (Located In Valve Block On Front Center Frame)	11-18
Check Valve Inspection (Located In Valve Block Below Vacuum Fan Motor Assembly)	11-19
Coulter Mounted Residue Wheels	11-9
Electrical Control Console Schematic	11-33
Electrical Control Console Schematic (With Optional Two-Speed Point Row Clutches)	11-41
Electrical Wiring Diagram For Light Package.....	11-32
Electrical Wiring Harness Schematic (On Planter)	11-37
Electrical Wiring Harness Schematic (On Tractor).....	11-35
Flow Control Valve Inspection (Located In Valve Block On Rear Center Frame).....	11-18
Flow Control Valve Inspection (Located In Valve Block On Front Center Frame)	11-18
Frame Mounted Coulter	11-7
Gauge Wheel Adjustment.....	11-4
Gauge Wheel Arm Bushing And/Or Seal Replacement	11-5
Gauge Wheel Arm Pivot Spindle Replacement	11-5
Granular Chemical Attachment.....	11-9
Hydraulic Schematic - Optional PTO Pump Drive And Oil Cooler System	11-53
Hydraulic Schematic - Planter Operation.....	11-44
Hydraulic Schematic - Vacuum Fan Motor System.....	11-52
Mounting Bolts And Hardware	11-1
Pilot Operated Check Valve Inspection (Located In Valve Block On R.H. Side Of Center Pivot)	11-17
Piston Pump Storage.....	11-31
Point Row Clutch Inspection	11-15
Preparation For Storage	11-32
Pressure Relief Valve Inspection (Located In Valve Block On Hitch)	11-18
Pressure Relief Valve Inspection (Located In Valve Block On Front Center Frame)	11-19
PTO Pump Drive And Oil Cooler Option.....	11-3
(Continued On Following Page)	

TABLE OF CONTENTS

MAINTENANCE (Continued)

Relief Valve Cartridge Inspection (Located In Valve Block Below Vacuum Fan Motor Assembly)	11-19
Residue Wheels (For Use With Frame Mounted Coulter).....	11-8
Row Marker Bearing Lubrication Or Replacement	11-26
Row Unit Mounted Disc Furrower	11-8
Row Unit Mounted No Till Coulter.....	11-9
Row Unit Mounted Residue Wheel	11-10
Row Marker Transport Stand Adjustment	11-26
SDS Seed Delivery System Auger Removal	11-11
Seed Meter Maintenance..... See "Seed Meter Operation/Maintenance" Section	
Seed Tube Guard/Inner Scraper	11-7
Solenoid Valve Inspection.....	11-19
Tire Pressure	11-2
Torque Values Chart	11-1

Troubleshooting

Closing Wheel Troubleshooting	11-4
KPM I/KPM II Stack-Mode Electronic Seed Monitors Troubleshooting	11-13
KPM III Electronic Seed Monitor Troubleshooting	11-14
Lift Circuit Troubleshooting	11-20
Piston Pump Troubleshooting	11-31
Point Row Clutch Troubleshooting	11-16
PTO Pump Drive And Oil Cooler Option Troubleshooting	11-3
Rotation Cylinder Circuit Troubleshooting.....	11-23
Row Marker Operation Troubleshooting	11-25
Seed Metering System Troubleshooting	See "Seed Meter Operation/ Maintenance" Section
Solenoid Valve Troubleshooting	11-19
Tongue Cylinder Circuit Troubleshooting	11-22
Wing Lock Cylinder Circuit Troubleshooting	11-24
Two-Speed Point Row Clutches.....	11-17
Wear Pad Replacement And Adjustment	11-28
Wheel Bearing Lubrication Or Replacement	11-27

PARTS LIST INDEX	P1
-------------------------------	-----------

PARTS SECTION NUMERICAL INDEX	P163
--	-------------

TO THE OWNER

KINZE Manufacturing, Inc. would like to thank you for your patronage. We appreciate your confidence in KINZE® farm machinery. Your KINZE® planter has been carefully designed to provide dependable operation in return for your investment.

This manual has been prepared to aid you in the operation and maintenance of the planter. It should be considered a permanent part of the machine and remain with the machine when you sell it.

It is the responsibility of the user to read and understand the Operator & Parts Manual in regards to safety, operation, lubrication and maintenance before operation of this equipment. It is the user's responsibility to inspect and service the machine routinely as directed in the Operator & Parts Manual. We have attempted to cover all areas of safety, operation, lubrication and maintenance; however, there may be times when special care must be taken to fit your conditions.

Throughout this manual the symbol  and/or the words **NOTE, IMPORTANT, CAUTION, WARNING** or **DANGER** are used to call your attention to important information. The definition of each of these terms follows:

NOTE: Indicates a special point of information or addresses a machine adjustment.

IMPORTANT: Indicates an operation or maintenance condition which , if not corrected, could result in damage to machine, property, crops or the environment.



CAUTION: Indicates a potentially hazardous situation which, if not avoided, may result in minor or moderate personal injury.



WARNING: Indicates a potentially hazardous situation which, if not avoided, could result in death or serious personal injury.



DANGER: Indicates an imminently hazardous situation which, if not avoided, will result in death or serious personal injury.



WARNING: Some photos in this manual may show safety covers, shields or lockup devices removed for visual clarity. **NEVER OPERATE** the machine without all safety covers, shields and lockup devices in place.

NOTE: Some photos in this manual may show prototype machines or similar models and vary slightly in appearance.

NOTE: Some photos and illustrations in this manual show optional attachments installed. Contact your KINZE® Dealer for purchase of optional attachments.

WARRANTY

The KINZE® Limited Warranty for your new machine is stated on the back of the retail purchaser's copy of the Warranty And Delivery Report form. Additional copies of the Limited Warranty can be obtained through your KINZE® Dealer.

Warranty, within the warranty period, is provided as part of KINZE's support program for registered KINZE® products which have been operated and maintained as described in this manual. Evidence of equipment abuse or modification beyond original factory specifications will void the warranty. Normal maintenance, service and repair is not covered by KINZE® warranty.

To register your KINZE® product for warranty, a Warranty And Delivery Report form must be completed by the KINZE® Dealer and signed by the retail purchaser, with copies to the Dealer, to the retail purchaser and to KINZE Manufacturing, Inc. Registration must be completed and sent to KINZE Manufacturing, Inc. within 30 days of delivery of the KINZE® product to the retail purchaser. KINZE Manufacturing, Inc. reserves the right to refuse warranty on serial numbered products which have not been properly registered.

If service or replacement of failed parts which are covered by the Limited Warranty are required, it is the user's responsibility to deliver the machine along with the retail purchaser's copy of the Warranty And Delivery Report to the KINZE® Dealer for service. KINZE® warranty does not include cost of travel time, mileage, hauling or labor. Any prior arrangement made between the Dealer and the retail purchaser in which the Dealer agrees to absorb all or part of this expense should be considered a courtesy to the retail purchaser.

KINZE® warranty does not include cost of travel time, mileage, hauling or labor.

INTRODUCTION

The Model 3650 Twin-Line[®] Planter is available in 30" row spacing configurations with a bulk seed delivery system or conventional seed hoppers. Optional Interplant[®] Packages and Liquid Fertilizer Attachments are available for use on the Model 3650 planter.

GENERAL INFORMATION

The information used in this manual was current at the time of printing. However, due to KINZE's continual attempts to improve its product, production changes may cause your machine to appear slightly different in detail. KINZE Manufacturing, Inc. reserves the right to change specifications or design without notice and without incurring obligation to install the same on machines previously manufactured.

Right hand (R.H.) and left hand (L.H.), as used throughout this manual, are determined by facing in the direction the machine will travel when in use, unless otherwise stated.

(TWL282)

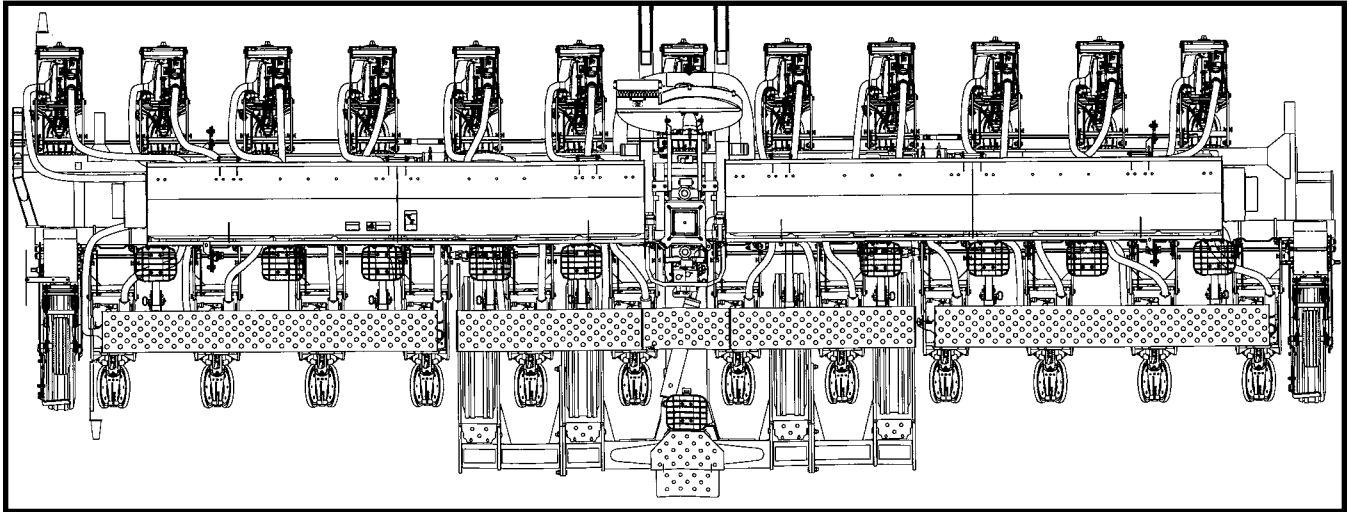

Model 3650 Twin-Line[®] SDS 12 Row 30" Planter Shown With Bulk Seed Delivery System And Interplant[®] Package And Even-Row Push Row Unit Options

(TWL280)

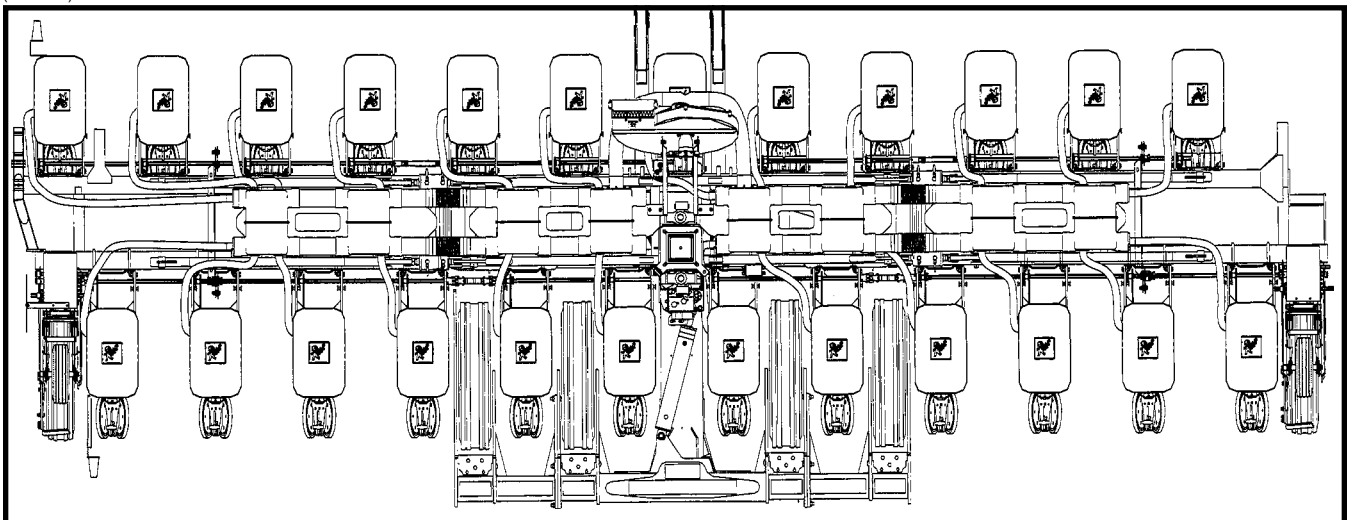

Model 3650 Twin-Line[®] Conventional 12 Row 30" Planter Shown With Individual Seed Hoppers And Interplant[®] Package And Even-Row Push Row Unit Options

INTRODUCTION

SPECIFICATIONS

BASE MACHINE TYPE - Pull Type (Hydraulically Rotates Endwise For Transport)

SEED METER TYPE - EdgeVac® Seed Metering System

EDGEVAC® SEED METERING SYSTEM INCLUDES -

EdgeVac® Seed Meters (Less Seed Discs), Meter Drive Clutches, No. 41 Chains, 20" Diameter Vacuum Fan With Mounting Components, Hydraulic Motor, Hoses And Fittings, 4" Diameter Vacuum Feed Hoses, Distribution Manifolds And 2" Diameter Vacuum Distribution Hoses

PLANTING UNIT TYPES - Push And Pull Row Units
- SDS Bulk Seed Delivery System Or Conventional Seed Hoppers

ROW SPACING	Standard	Interplant® Package
	12 Row Narrow - 30" Rows	23/24 - 15" Rows
	16 Row Narrow - 30" Rows	31/32 - 15" Rows

DRIVE SYSTEM - Spring-Loaded Contact Drive System
- 7.50" x 20" Rib Implement Wing Tire - Two On 12 Row, Four On 16 Row
- 4.80" x 8" Contact Drive Tire - Two On 12 Row, Four On 16 Row
- No. 40 Chain And Spring-Loaded Idlers
- Point Row Clutches Standard
- 7/8" Hex Drill And Drive Shafts And End Mounted Seed Transmissions

TRANSPORT TIRES - Equipped With Four 41 x 11R22.5" Radial Load Range H Tubeless Rib Implement Tires
- Adjustable Height Wheels For Ridge Planting

LIFT - Master/Slave Hydraulics
- 12 Row - 2 Center Lift (Master) Cylinders, 1 Cylinder (Slave) Per Wing Wheel Module (2 Cylinders)
- 16 Row - 2 Center Lift (Master) Cylinders, 2 Cylinders (Slave) Per Wing Wheel Module (4 Cylinders)

ROW MARKERS - Independently Controlled Two-Fold Low Profile With Depth Band On Row Marker Blade

SEED METER/VACUUM SYSTEM HYDRAULIC REQUIREMENTS

- 13 GPM @ 2000 PSI
- Zero PSI Case Drain Plus One SCV For Vacuum Fan Hydraulic Motor

MACHINE OPTIONS

- Electronic Seed Monitors
 - KPM I
 - KPM II Stack-Mode With Magnetic Distance Sensor Or Radar Distance Sensor
 - KPM III With Magnetic Distance Sensor Or Radar Distance Sensor
- Stack-Mode Monitor (SMM) Console Package For Use With Interplant® Package
- Two-Speed Point Row Clutch Package - Allows half width planting and reduced rate planting (Available through KINZE® Repair Parts)
- Interplant® Package Options
- Even-Row Push Row Unit Package
- Auxiliary Work Lights Package
- Liquid Fertilizer With Piston Pump And Fertilizer Opener Options
- Liquid Fertilizer Low Rate Check Valve Option
- Rear Trailer Hitch
- 2-Point Hitch Option

ROW UNIT OPTIONS/ATTACHMENTS

- Seed Meter Discs
- Closing Wheel Options
 - Rubber "V" Closing Wheels
 - Cast Iron "V" Closing Wheels
- Hopper Panel Extension Package
- Granular Chemical Application
- Row Unit Mounted No Till Coulter
- Coulter Mounted Residue Wheels
- Row Unit Mounted Disc Furrowers
- Row Unit Mounted Residue Wheel
- Frame Mounted Coulter
- Residue Wheel Attachment Frame Mounted Coulter

SPECIFICATIONS

BULK FILL (SDS) DIMENSIONS/WEIGHTS		
PLANTER SIZE	12 Row 30"	16 Row 30"
OPERATING WIDTH	31' 2"	41' 2"
OPERATING LENGTH	22' 4"	25' 4"
TRANSPORT WIDTH Standard or push row units	11' 2"	11' 2"
TRANSPORT LENGTH*	36' 10"	46' 10"
TRANSPORT HEIGHT	11' 0"	11' 4"
WEIGHT**	17,613 lbs.	21,908 lbs.

* Add 1' 6" to length in transport position when equipped with the even-row push row unit.

** Base Machine weights include planter frame with row markers, drive components, tires and wheels, hydraulic cylinders and hoses, 12VDC control console, transport safety chain, Bulk Seed Delivery System, KINZE® plateless row units less closing wheels, mini-seed hoppers, dual quick-adjustable down force springs, EdgeVac® meters (less seed discs) and vacuum seed metering system fan, manifolds and hoses.

CONVENTIONAL DIMENSIONS/WEIGHTS		
PLANTER SIZE	12 Row 30"	16 Row 30"
OPERATING WIDTH	31' 2"	41' 2"
OPERATING LENGTH	22' 4"	25' 4"
TRANSPORT WIDTH Standard or push units	11' 2"	11' 2"
TRANSPORT LENGTH*	36' 10"	46' 10"
TRANSPORT HEIGHT	11' 0"	11' 4"
WEIGHT**	14,669 lbs.	18,084 lbs.

* Add 1' 6" to length in transport position when equipped with the even-row push row unit.









** Base Machine weights include planter frame with row markers, drive components, tires and wheels, hydraulic cylinders and hoses, 12VDC control console, transport safety chain, KINZE® plateless row units less closing wheels, seed hoppers with lids, dual quick-adjustable down force springs, EdgeVac® meters (less seed discs) and vacuum seed metering system fan, manifolds and hoses.

NOTE: L.H. transport wheel and axle stub assembly is removable for truck transport of base machine at 8' 6".

SAFETY PRECAUTIONS

Safe and careful operation of the tractor and planter at all times will contribute significantly to the prevention of accidents.

Since a large portion of farm accidents occur as a result of fatigue or carelessness, safety practices should be of utmost concern. Read and understand the instructions provided in this manual and on the warning signs. Review these instructions frequently! Listed below are other safety suggestions that should become common practice.

-  **Never allow the planter to be operated by anyone who is unfamiliar with the operation of all functions of the unit. All operators should read and thoroughly understand the instructions given in this manual prior to moving the unit.**
-  **Never permit any persons other than the operator to ride on the tractor.**
-  **Never ride on the planter or allow others to do so.**
-  **Always make sure there are no persons near the planter when row marker assemblies are in operation or when rotating the planter.**
-  **Always keep hands, feet and clothing away from moving parts. Do not wear loose-fitting clothing which may catch in moving parts.**
-  **Always wear protective clothing, substantial shoes and suitable hearing and eye sight protectors applicable for the situation.**
-  **Do not allow anyone to stand between the tongue or hitch and the towing vehicle when backing up to the planter.**
-  **Be aware of bystanders, particularly children! Always look around to make sure it is safe to start the engine of the towing vehicle or move the planter. This is particularly important with higher noise levels and quiet cabs, as you may not hear people shouting.**
-  **Use a tractor equipped with a roll-over-protective-system and fasten your seat belt prior to starting the engine.**



Before operating the planter for the first time and periodically thereafter, check to be sure the lug bolts on the transport wheels are torqued properly. This is especially important if the planter is to be transported for a long distance.



Never work under the planter while in raised position without using manual safety lockup.



Install safety lockup devices on markers prior to transporting the planter or working around the unit.

D12070405

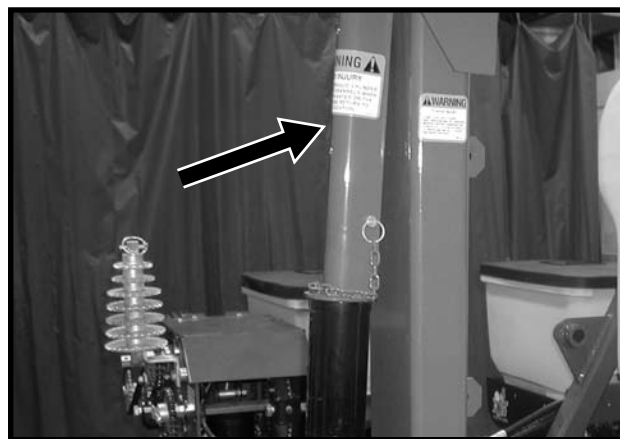

Row Marker Lockup (Conventional Planter Shown)



Watch for obstructions such as wires, tree limbs, etc. when folding markers.



To avoid serious injury or death, care must be taken when operating row markers around overhead power lines.



On machines where the outer transport wheel on the left side of the planter is bolt-on to allow legal width truck shipment, always install outer transport wheel assembly prior to unloading. DO NOT REMOVE THIS ASSEMBLY AFTER PLANTER IS ASSEMBLED FOR USE. DO NOT fold planter or tow planter while the outer transport wheel is removed. Tipping may occur because of narrow wheel base.



The seed and fertilizer metering systems of this planter are designed to be driven by ground tires. Hydraulic motors power the bulk seed distribution system. The use of aftermarket hydraulic, electric or PTO drives may create serious safety hazards to you and others nearby. Always follow all appropriate safety standards and practices to protect you and others near this planter from injury.

SAFETY PRECAUTIONS

-  Always install tongue safety pin, manual safety lockup and transport latch locking pin before transporting planter.

D071803314

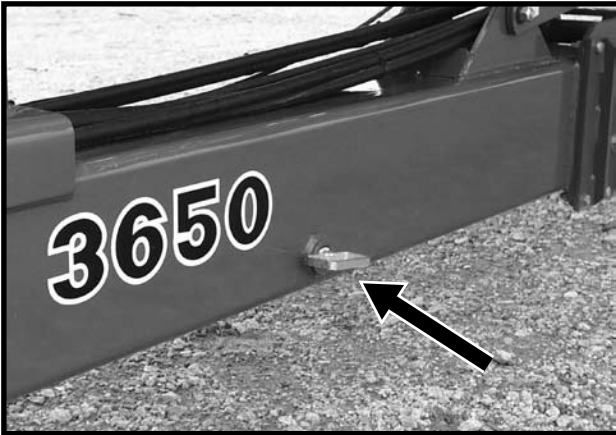

Tongue Safety Pin

D071603307

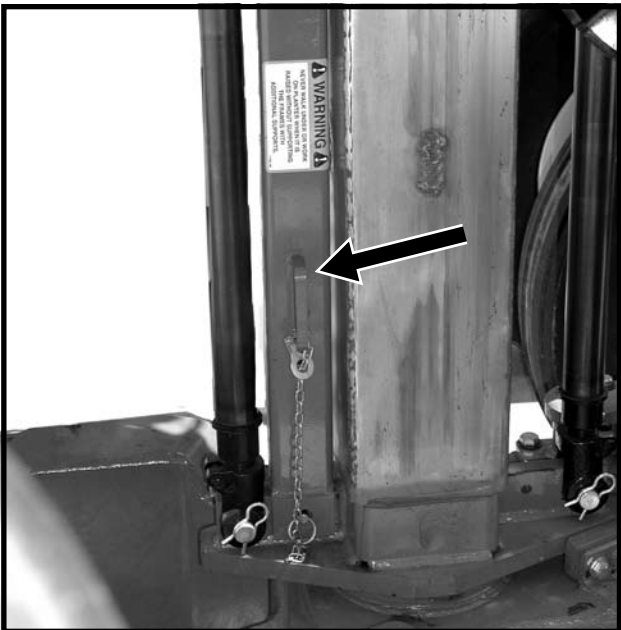



Manual Safety Lockup

D032901113





Transport Latch Locking Pin

-  This machine has been designed and built with your safety in mind. Do not make any alterations or changes to this machine. Any alteration to the design or construction may create safety hazards.

-  Always follow federal, state/provincial and local regulations when towing farm equipment on a public highway. Only a safety chain (not an elastic or nylon/plastic tow strap) should be used to retain the connection between the towing and towed machines in the event of separation of the primary attaching system.

-  Check to be sure all safety/warning lights are working properly before transporting the machine on public roads.

-  Avoid transporting loaded planter whenever possible. When it is necessary to transport the planter with the hoppers loaded, the added weight should be distributed evenly on the planter frame before rotating the planter.

-  Limit towing speed to 15 MPH.

-  Transport stability is critical. The gross weight of the tractor must be greater than the gross weight of the planter. Gross weight varies with planter attachments. Tow 24 Row 30" planters with farm tractor of a minimum 200 HP. Tow 32/36 Row 30" planters with farm tractor of a minimum 250 HP.

-  Always make sure safety/warning lights, reflective decals and SMV sign are in place and visible prior to transporting the machine on public roads. In this regard, check federal, state/provincial and local regulations.

-  Allow for unit length when making turns.

-  Always drive at a safe speed relative to local conditions and ensure your speed is low enough for an emergency stop to be safe and secure. Keep speed to a minimum.

-  Reduce speed prior to turns to avoid the risk of overturning.

SAFETY PRECAUTIONS



Always keep the tractor in gear to provide engine braking when going downhill. Do not coast.



Avoid sudden uphill turns on steep slopes.



Be a safe and courteous driver. Always yield to oncoming traffic in all situations, including narrow bridges, intersections, etc.



Rim and tire servicing can be dangerous. Explosive separation of a tire and rim parts can cause serious injury or death.



Agricultural chemicals used with this unit can be dangerous. Improper selection or use can seriously injure persons, animals, plants, soil and other property. **BE SAFE:** Select the right chemical for the job. Handle it with care. Follow the instructions on the container label and of the equipment manufacturer.



Store the planter in an area away from human activity. **DO NOT** permit children to play on or around the stored unit.



Make sure the parked machine is on a hard, level surface. Wheel chocks may be needed to prevent unit from rolling.



Never operate vacuum fan with cover removed.



Always wear ear protection when working around operating vacuum fan.

SAFETY PRECAUTIONS

SAFETY WARNING SIGNS

The “WARNING” signs illustrated on these pages are placed on the machine to warn of hazards. The warnings found on these signs are for your personal safety and the safety of those around you. OBSERVE THESE WARNINGS!

- Keep these signs clean so they can be readily observed. Wash with soap and water or cleaning solution as required.
- Replace “WARNING” signs should they become damaged, painted over or if they are missing.
- Check reflective decals and SMV sign periodically. Replace if they show loss of any of their reflective properties.
- When replacing decals, clean the machine surface thoroughly using soap and water or cleaning solution to remove all dirt and grease.

NOTE: Style and locations of SMV sign, reflective decals and safety/warning lights conform to ANSI/ASAE S279.13 DEC2005 and ANSI/ASAE S276.6 JAN2005.

D032901113

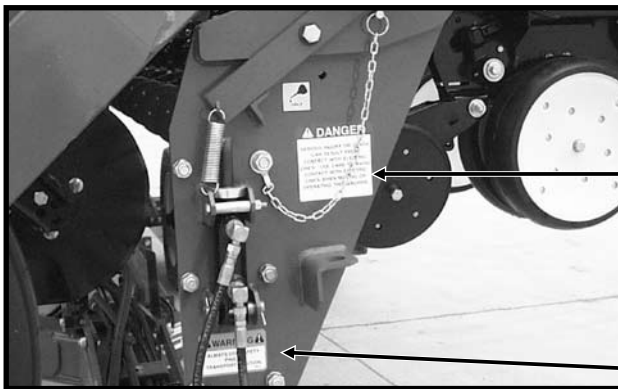

Part No. G7100-117 (Qty. 1)



Part No. G7100-02 (Qty. 1)

D071603349



Part No. G7100-75
(Qty. 4 - Front & Rear/Left & Right)

SAFETY WARNING SIGNS

D09070434b

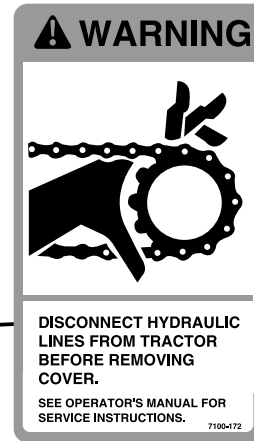

Part No. G7100-172
(Qty. 2 - One On Outer End Of Each Bulk Seed Hopper)

D032901164

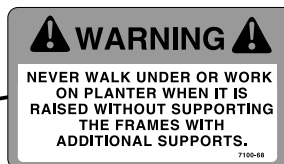
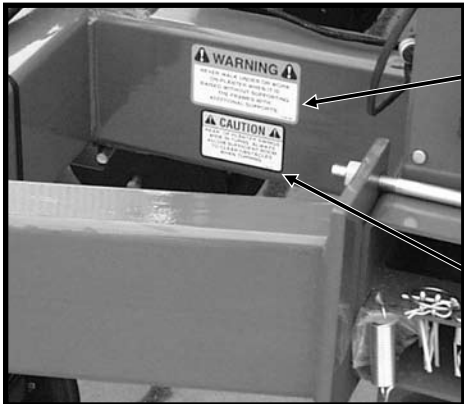

Part No. G7100-68
(Qty. 2 - One On Each End Of Planter)

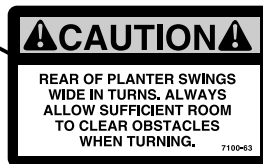

Part No. G7100-63
(Qty. 2 - One On Each End Of Planter)

Shown With Row Marker Mount Included With Optional Even-Row Push Row Unit Package

D022102107



SAFETY WARNING SIGNS

D071803204



Part No. G7100-68
(Qty. 2 - R.H. Side Of Planter - Front/Rear)

D071803203



Part No. G7100-200
(Qty. 2 - L.H. Side Of Planter - Front/Rear)

D071603205

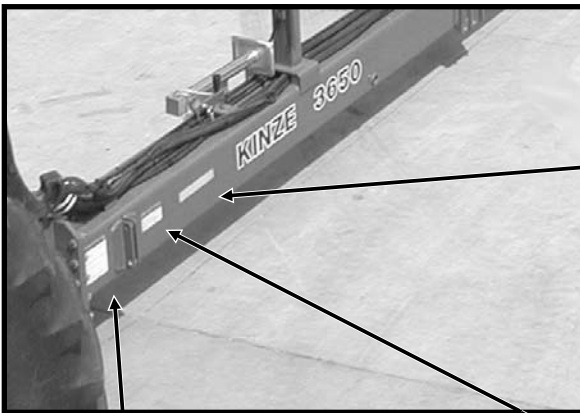

Part No. G7100-259 Amber Reflective Decal
(Qty. 1)



Part No. G7100-46 (Qty. 1)



Part No. G7100-90 (Qty. 1)

SAFETY WARNING SIGNS

D12070404



Part No. G7100-259 Amber Reflective Decal (Qty. 1)



Part No. G7100-302 (Qty. 1)

D071803317

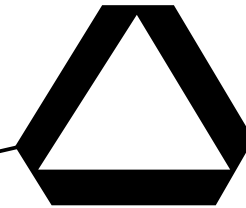
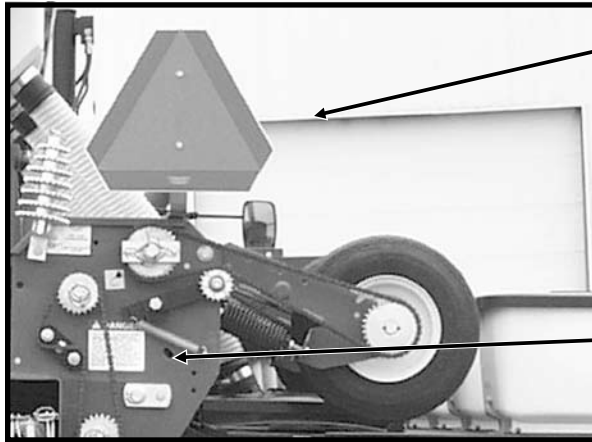

Part No. GD2199 (Qty. 1)



Part No. G7100-89 (Qty. 2 - Located On Wheel Modules On Both Ends Of Planter)

A12177b

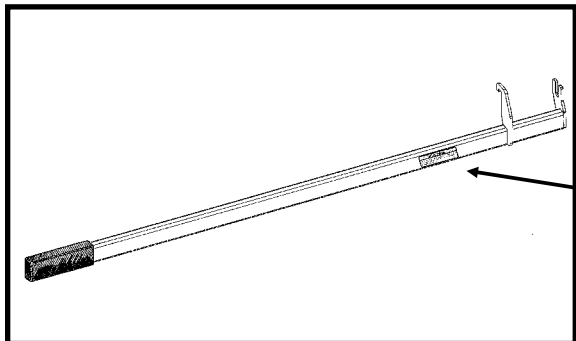

Part No. G7100-249 (With Optional Interplant® Package) (Qty. 1 - Located On Interplant® Lift Lever)

SAFETY WARNING SIGNS

D010704102a

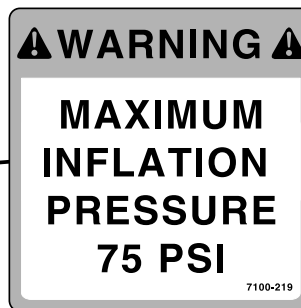

Part No. G7100-219 (Qty. 1 Per 41 x 11R22.5" Transport Wheel)

D010704101



Part No. G7100-215 (Qty. 1 - Located On Outside End Of Stub Axle)

D071803318



Part No. G7100-262 Amber Reflective Decal (Qty. 6 On 12 Row 30" And Qty. 8 On 16 Row 30" - Located On Every Other Row Unit Beginning On The First Row Unit On The L.H. End Of The Planter - Rear-Facing In Planting Position/Side-Facing In Transport Position)



Part No. G7100-259 Amber Reflective Decal (Qty. 6 On 12 Row 30" And 8 On 16 Row 30" - Located On Every Other Row Unit Beginning On The First Row Unit On The L.H. End Of The Planter - Rear-Facing In Planting Position/Side-Facing In Transport Position) **(With Optional Granular Chemical)**



Part No. G7100-260 Orange Reflective Decal (Qty. 2 - One Located On R.H. And L.H. Rear Sides Of Axle)



Part No. G7100-258 Red Reflective Decal (Qty. 2 - One Located On R.H. And L.H. Rear Sides Of Axle)

SAFETY WARNING SIGNS

(TWL226)



Part No. G7100-259 Amber Reflective Decal (Qty. 7 On 12 Row 30" And Qty. 9 On 16 Row 30" - Located On The Front Side Of The Front Toolbar And Marker Mounts - Forward-Facing In Planting Position/Side-Facing In Transport Position)

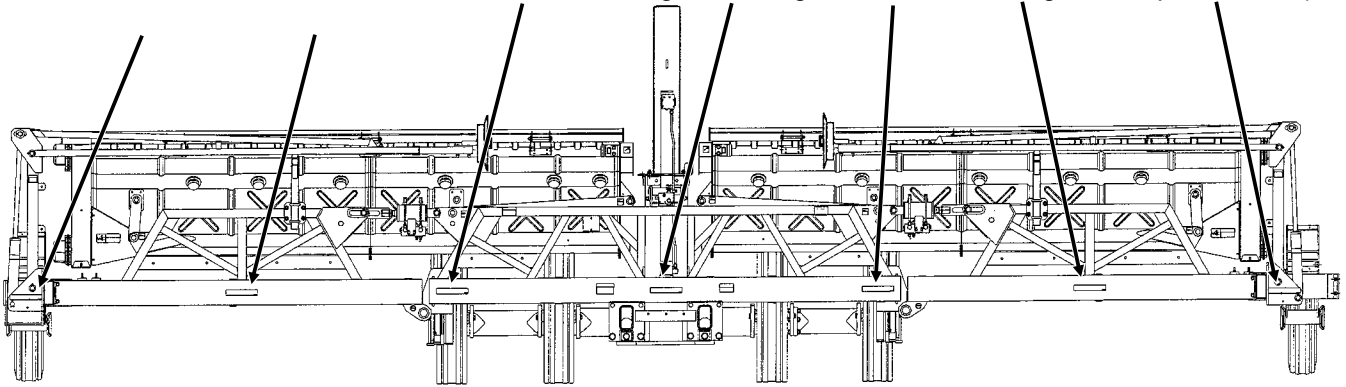

(TWL174b)

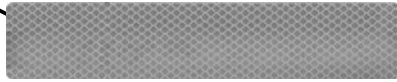
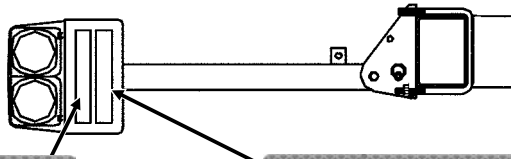

Part No. G7100-258 Red Reflective Decal (Qty. 1 - Located On The Front Light Bracket On The L.H. Wing Of The Planter - Rear-Facing In Transport Position)

Part No. G7100-260 Orange Reflective Decal (Qty. 1 - Located On The Front Light Bracket On The L.H. Wing Of The Planter - Rear-Facing In Transport Position)

(TWL174b/RU120e)

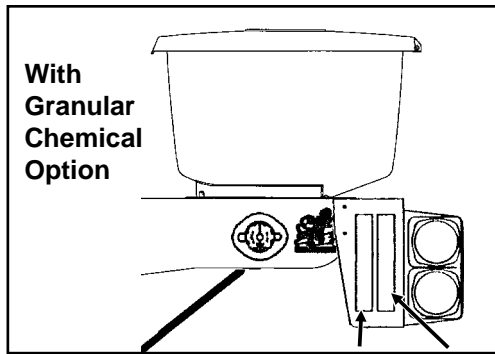
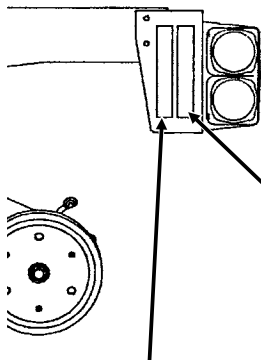

Part No. G7100-260 Orange Reflective Decal (Qty. 1 - Located On The Rear Light Bracket On The L.H. Wing Of The Planter - Rear-Facing In Transport Position)

Part No. G7100-258 Red Reflective Decal (Qty. 1 - Located On The Rear Light Bracket On The L.H. Wing Of The Planter - Rear-Facing In Transport Position)

SAFETY WARNING SIGNS

D012204101



Part No. G7100-260 Orange Reflective Decal
(Qty. 6 - Located On Catwalk End Plates)
(If Applicable)

(PLTR159)

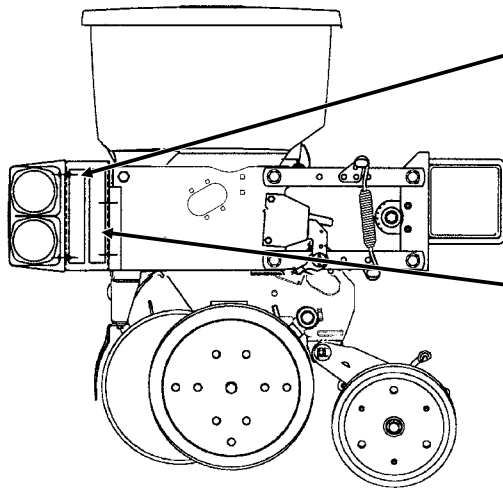

Conventional Seed Hopper Shown

Part No. G7100-258 Red Reflective Decal
(With Optional Interplant® Package)
(Qty. 1 - Located On Light Bracket On The
L.H. Wing Of The Planter - Rear-Facing In
Transport Position)

Part No. G7100-260 Orange Reflective Decal
(With Optional Interplant® Package)
(Qty. 1 - Located On Light Bracket On The
L.H. Wing Of The Planter - Rear-Facing In
Transport Position)

SAFETY WARNING SIGNS

LF091903101a

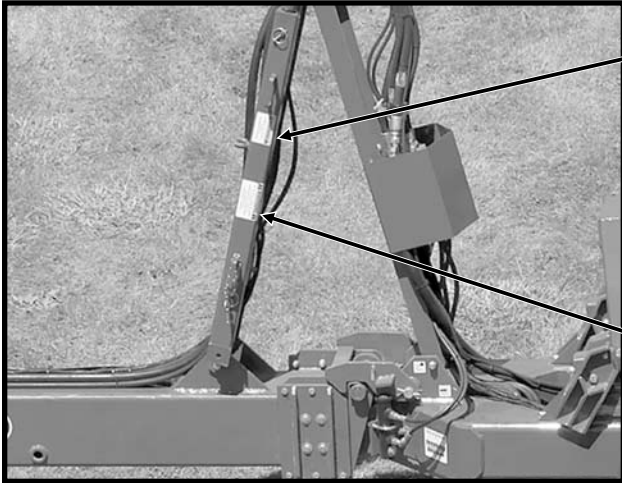

Part No. G7100-68
(Qty. 1 - On Manual Safety Lockup)



Part No. G7100-200
(Qty. 1 - On Manual Safety Lockup)

(TWL262)

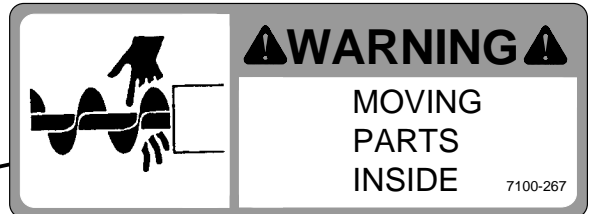
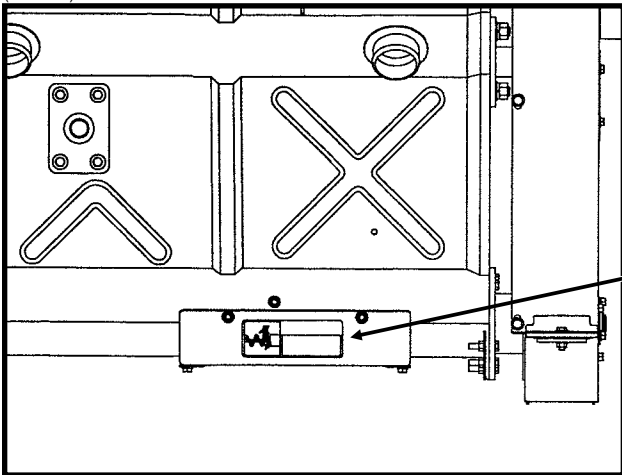

Part No. G7100-267 (Qty. 4 - On Front And Rear Of Screen Assembly Located On Outer End Of Each Bulk Seed Hopper)

D071803222a

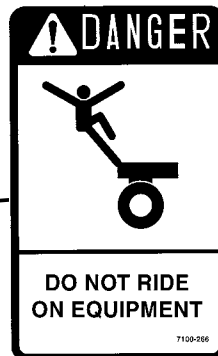

Part No. G7100-266 (Qty. 1)
(SDS Planters Only)

SAFETY WARNING SIGNS

D021102216



Part No. G7100-266
(Qty. 2 - One on Each Bulk Seed Hopper Lid)



Part No. G7100-75 (Qty. 2 - One On Each Bulk Seed Hopper Lid)

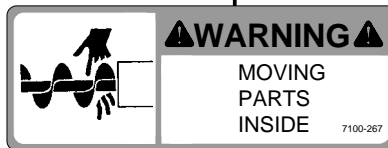

Part No. G7100-267 (Qty. 2 - One On Each Bulk Seed Hopper Lid)

D071803105

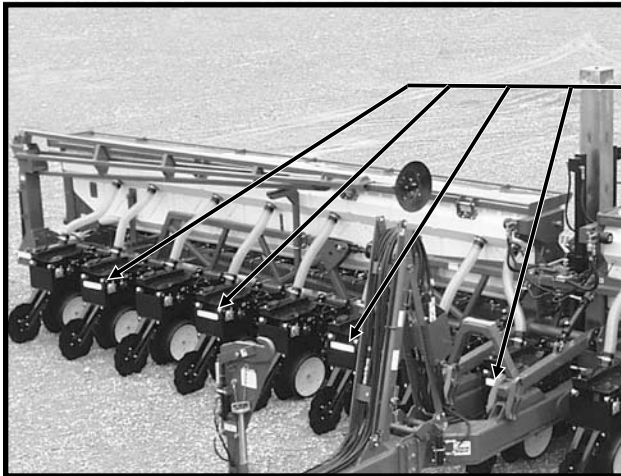

Part No. G7100-259 Amber Reflective Decal **(With Optional Interplant® Package And/Or Even-Row Push Row Unit Package)**
(Qty. 5 On 12 Row 30" And 7 On 16 Row 30" - Located On The Front Of Every Other Interplant® Push Row Unit Beginning At The Center Of The Planter - Side-Facing In Transport Position)

06039901

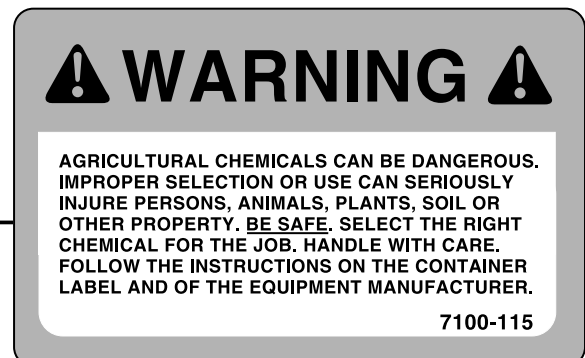

Part No. G7100-115 **(With Optional Granular Chemical)** (1 Per Row Unit - Located On Under-side Of Each Optional Granular Chemical Hopper Lid)

SAFETY WARNING SIGNS

D12070405

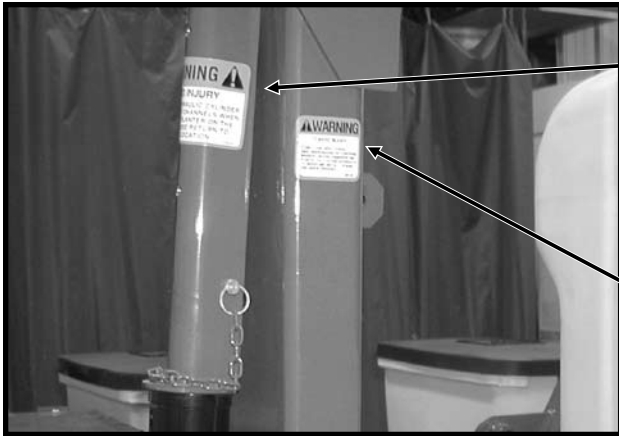

Part No. G7100-83
(Qty. 2 - One Per Marker)



Part No. G7100-42
(Qty. 4 - Two Per Marker)

(TWL279)

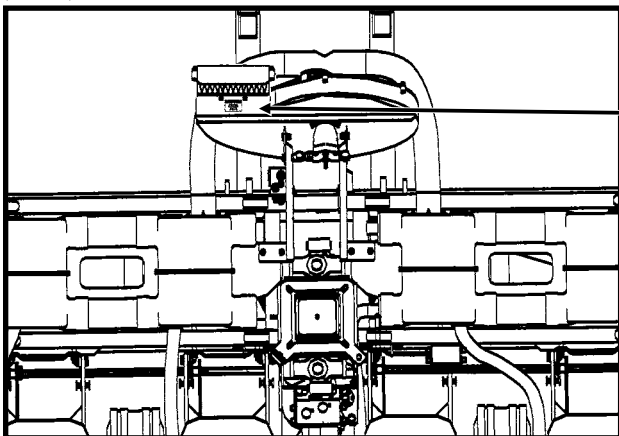

Part No. G7100-301 (Qty. 2 - One On Each Side Of Fan)

MACHINE OPERATION

The following information is general in nature and was written to aid the operator in preparation of the tractor and planter for use, and to provide general operating procedures. The operator's experience, familiarity with the machine and the following information should combine for efficient planter operation and good working habits.

IMPORTANT: Always raise the planter out of the ground when making sharp turns or backing up.

The KINZE EdgeVac® Seed Metering System includes seed meters, seed discs and an air system consisting of a hydraulic driven vacuum fan which draws air through the manifolds and hoses and the seed meters on each row unit.

! WARNING: Never operate vacuum fan with cover removed.

ROW MARKER SAFETY LOCKUP **!**

Install safety lockups over marker cylinder rods when transporting the planter or working around the planter. When lockups are not in use, store in the storage position provided on the first stage marker arm.

! DANGER: To avoid serious injury or death, keep others away when raising or lowering markers.

D120804101

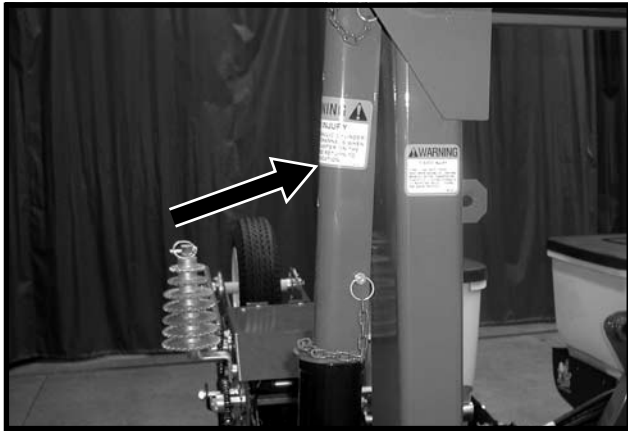

Row Marker Safety Lockup In Locked Position

D032901130

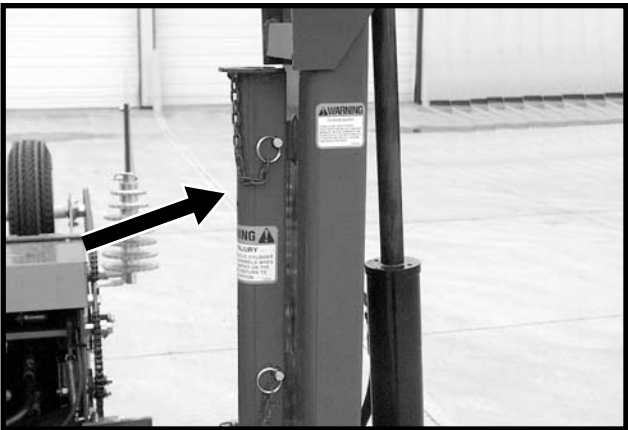

Row Marker Safety Lockup In Storage Position

MANUAL SAFETY LOCKUP **!**

Never allow anyone to work around or under the planter without first securing the manual safety lockup in the transport position. When transporting the planter use the manual safety lockup for added safety.

D071603307

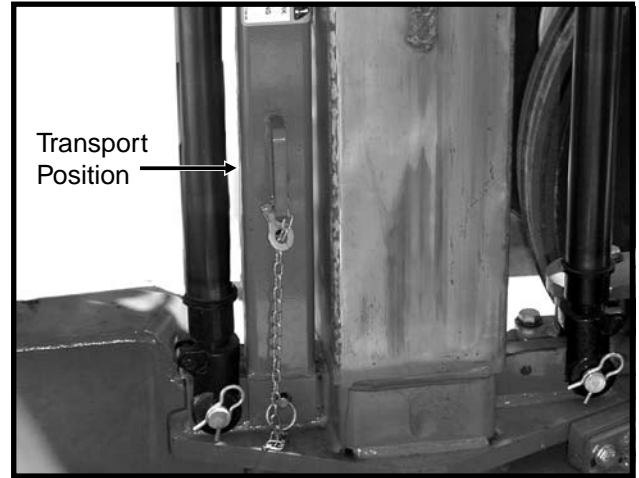

Manual Safety Lockup In Transport Position

D071603212

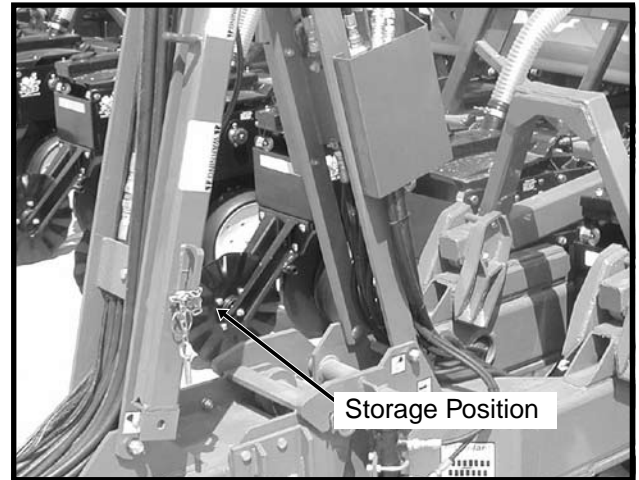

Manual Safety Lockup In Storage Position

For field operation remove the manual safety lockup and store in the storage position on the L.H. side of the hose take-up on the planter hitch.

MACHINE OPERATION

TONGUE SAFETY PIN

The tongue safety pin when installed will prevent the tongue cylinder from retracting should hydraulic failure occur or a sudden stop be made when transporting the planter. Never transport the planter without installing the tongue safety pin.

D071803314

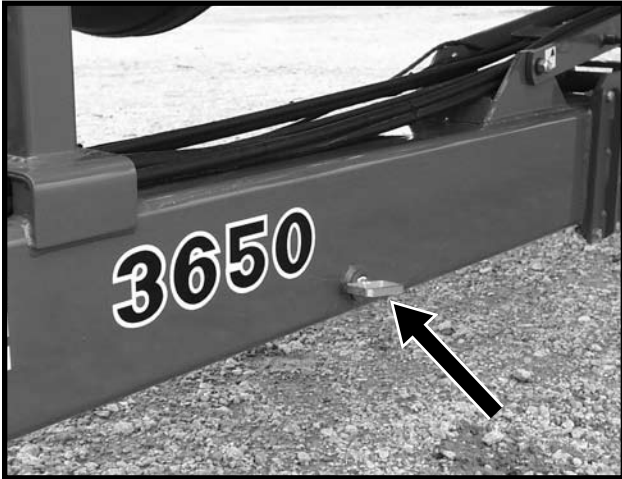

Tongue Safety Pin Installed For Transport

D032901120a

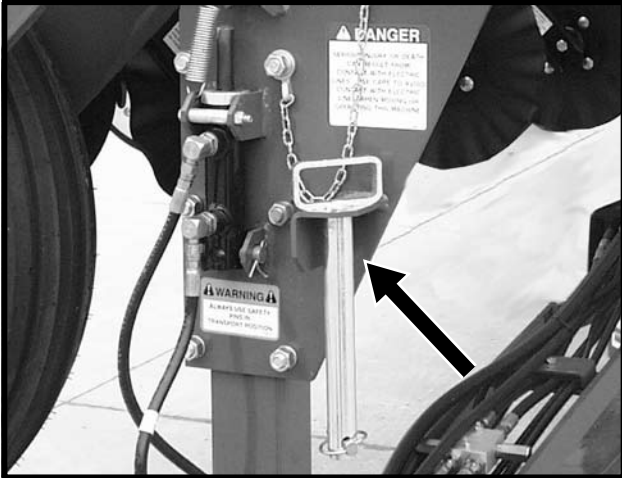

Tongue Safety Pin Stored For Field Operation

For field operation remove the tongue safety pin and store in the location provided on the transport latch post on the tongue of the planter.

TRANSPORT LATCH LOCKING PIN

The transport latch locking pin when installed will prevent the latch bar from disengaging and allowing the planter frame to swing away. Never transport the planter without installing the transport latch locking pin.

D032901113

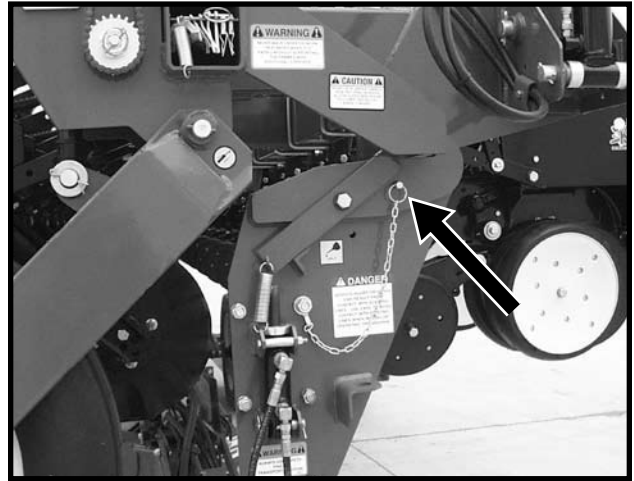

Transport Latch Locking Pin Installed For Transport

D032901114

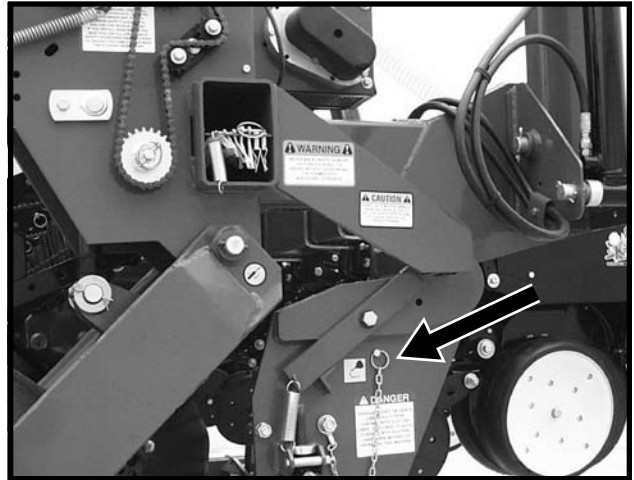

Transport Latch Locking Pin Stored For Field Operation

For field operation remove the transport latch locking pin and store in the hole provided on the latch post.

MACHINE OPERATION

INITIAL PREPARATION OF THE PLANTER

Lubricate the planter and row units per the lubrication information in this manual. Make sure all tires have been properly inflated. Check all drive chains for proper tension, alignment and lubrication.



DANGER: The outer transport wheel/axle extension on the left side of the machine is shipped not bolted on to allow narrower width truck shipment. **DO NOT REMOVE THIS ASSEMBLY AFTER PLANTER IS ASSEMBLED FOR USE. DO NOT** fold planter or tow planter while the outer transport wheel is removed. Tipping may occur because of narrow wheel base.

TRACTOR REQUIREMENTS

Consult your dealer for information on horsepower requirements and tractor compatibility. Requirements will vary with planter options, tillage and terrain.

A 12 volt DC electrical system is required on all 3650 planters.

Four dual remote hydraulic outlets (SCV) are required on SDS planters. Three dual remote hydraulic outlets (SCV) are required on conventional planters. One SCV operates the markers, wing lock and fold; one SCV operates the planter lift; one SCV, along with a zero pressure case drain, operates the vacuum fan motor; and one operates the hydraulic motor on SDS planters only.

Maximum hydraulic flow rate of 13 GPM @ 2000 PSI is required (in addition to planter lift/marker hydraulic requirements) to operate the vacuum fan motor.

IMPORTANT: Connect hydraulic motor case drain to a case drain return line with zero PSI on the tractor. Failure to connect to a return with zero PSI will cause damage to the hydraulic motor shaft seal. Warranty will not apply on damaged motors resulting from improper hydraulic line connection. **DO NOT** connect hydraulic motor case drain to a SCV outlet or motor return circuit connection. Contact tractor manufacturer for specific details on “zero pressure return”.

NOTE: PTO pump drive and oil cooler kits are available, from KINZE® through your KINZE® Dealer, if your tractor does not have sufficient hydraulic pump capacity. See “PTO Pump Drive And Oil Cooler Option” on following page.

NOTE: A Flow Control Needle Valve Kit, to provide a flow control option for tractors that are not equipped with a method for finite adjustment of hydraulic flow, is available from KINZE® Repair Parts through your KINZE® Dealer.

D04050604

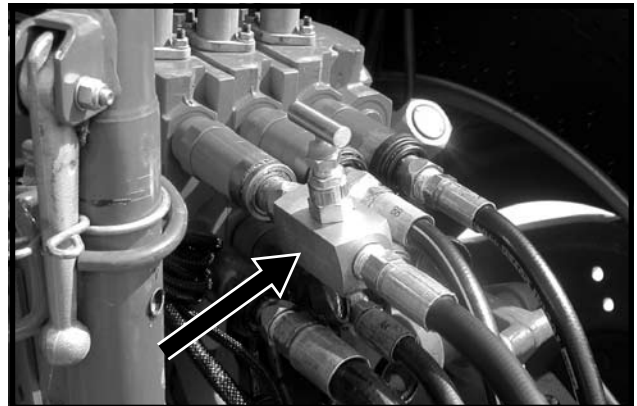

G1K426 Needle Valve Kit

MACHINE OPERATION

PTO PUMP DRIVE AND OIL COOLER OPTION

The PTO pump drive and oil cooler option is designed to accommodate tractors with less than the required hydraulic output necessary to operate the hydraulic-driven vacuum fan in addition to other planter hydraulic requirements. A 1 $\frac{3}{8}$ "-21 spline 1000 RPM PTO is required to operate the PTO-driven hydraulic pump. The option consists of a 1 $\frac{3}{8}$ "-21 spline, 13.5 GPM 2000 PSI pump, 10 gallon capacity hydraulic reservoir, 15 GPM-rated oil cooler, spin-on 10-micron oil filter and required hydraulic valves and fittings.

A 12 volt battery connection is required to power the vacuum fan digital gauge. Connect the "red" wire to the positive (+) battery terminal and the "black" wire to the negative (-) battery terminal.

(TWL290c/TWL294/TWL306)

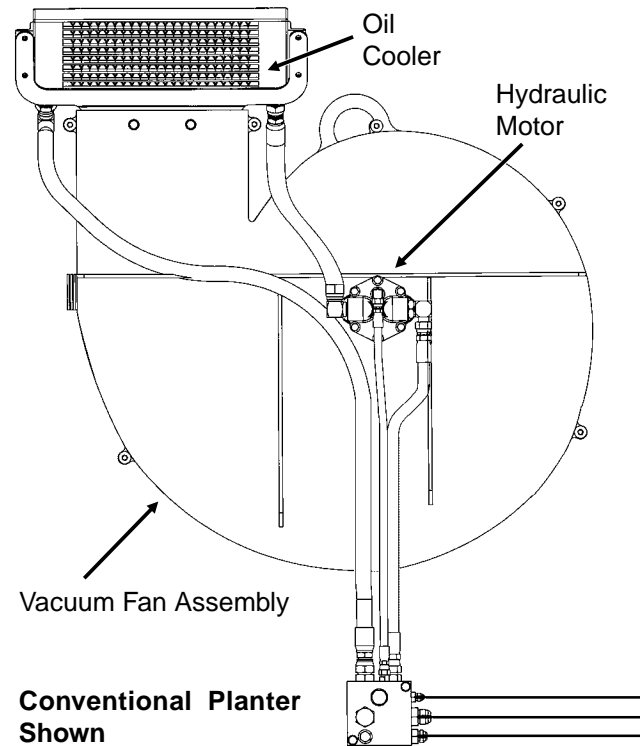

PTO-Driven Hydraulic Pump

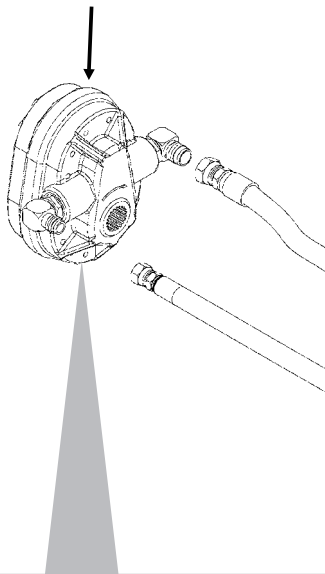

Oil Filter (10 Micron)

Flow Control Valve

Reservoir

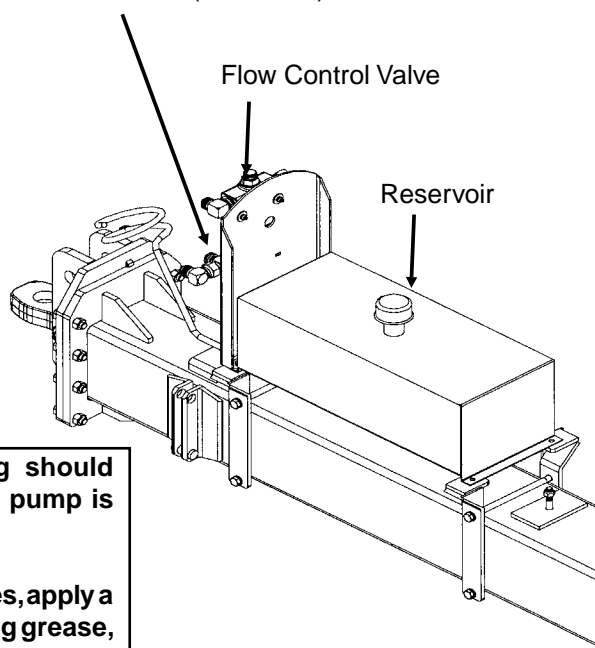

IMPORTANT: The PTO shaft coupling should be cleaned and greased each time the pump is installed.

IMPORTANT: To extend life of shaft splines, apply a coating of high-speed industrial coupling grease, such as Chevron® Coupling Grease, that meets AGMA CG-1 and CG-2 Standards.

(The Chevron® trademark is owned by Chevron Products Company. AGMA is the acronym for the American Gear Manufacturers Association)

MACHINE OPERATION

TRACTOR PREPARATION AND HOOKUP

D101602106



NOTE: A 2-Point Hitch Option, which converts the planter from drawn to semi-mounted, is available for use with Category 3N or 3 three-point hitch designs. The safety chain is not applicable with the 2-point hitch.

1. Adjust tractor drawbar to 13"-17" above the ground. Adjust the drawbar so the hitch pin hole is directly below the center line of the PTO shaft. Make sure the drawbar is in a stationary position. See page 6-14 when using the even-row push row unit option.
2. Install control console on tractor in a convenient location within reach of the operator and close to the hydraulic controls. Mount control console securely and route power cord to the power source.

The control console operates on 12 volt DC only. If two 12 volt batteries are connected in series, ALWAYS make power connection on the battery which is grounded to the tractor chassis.

If two 6 volt batteries are connected in series, make sure the power connection provides 12 volt DC across the positive terminal on one battery and negative terminal of the second battery.
3. Back tractor to planter and connect with 1 1/4" - 1 1/2" diameter hitch pin. If the tractor is not equipped with a hitch pin locking device, make sure hitch pin is secured with a locking pin or cotter pin.
4. The auxiliary attaching system (transport safety chain) provided with your planter should be used to ensure the connection is retained between the planter and tractor in the event of a hitch pin/drawbar failure. The safety chain is to be attached to the planter using an unused clevis mounting hole on the planter hitch. The attaching hardware should be torqued to 840 ft. lbs. Connect the hook end of the chain securely around a tractor frame member.
5. Connect hydraulic hoses to tractor ports (SCV) in a sequence which is both familiar and comfortable to the operator.

NOTE: Many tractors have one SCV that has priority over the other valves. The vacuum fan motor should be connected to the priority valve to ensure the fan motor speed is not interrupted when other remotes are activated. Refer to your tractor operator manual for connecting the vacuum fan motor.

3650 Conventional Only - Hydraulic hoses are as follows:

- Red AA - Lift Functions (Return)
- Red BB - Lift Functions (Pressure)
- Blue AA - Marker And Fold/Unfold Functions (Return)
- Blue BB - Marker And Fold/Unfold Functions (Pressure)
- Green RR - 3/4" Hose From Vacuum Fan Motor (Return)
- Green PP - 1/2" Hose To Vacuum Fan Motor (Pressure)
- Green Case Drain - 3/8" Hose From Vacuum Fan Motor

3650 SDS Only - Hydraulic hoses are as follows:

- Red AA - Lift Functions (Return)
- Red BB - Lift Functions (Pressure)
- Blue AA - Marker And Fold/Unfold Functions (Return)
- Blue BB - Marker And Fold/Unfold Functions (Pressure)
- Green AA - Seed Delivery System Functions/ Hose From Vacuum Fan Motor (Return)
- Green BB - Seed Delivery System Functions (Pressure)
- Green PP - 1/2" Hose To Vacuum Fan Motor (Pressure)
- Green CDCaseDrain-3/8"HoseFromVacuumFan Motor

NOTE: The vacuum fan motor and SDS system share a common 3/4" return hose. The return hose should be connected to a motor return circuit (see tractor operator manual) so the SDS system or vacuum fan motor can be operated independently. If a motor return valve is not available, the 3/4" return hose should be connected to the same remote as the vacuum fan motor to prevent damage to the vacuum fan motor seals.



DANGER: Before applying pressure to the hydraulic system, make sure all connections are tight and hoses and fittings have not been damaged. Hydraulic fluid escaping under pressure can have sufficient force to penetrate skin, causing injury or infection.

IMPORTANT: Always wipe hose ends to remove any dirt before connecting couplers to tractor ports.

6. Connect cable on planter to control console cable on tractor. Connect ASAE Standards 7 terminal connector for safety/warning lights on planter to ASAE Standards receptacle on tractor. If your tractor is not equipped with an ASAE Standards receptacle, check with your tractor manufacturer for availability. Check to be sure warning lights on planter are working in conjunction with warning lights on tractor.

Connect harness on planter to digital vacuum gauge console on tractor. Connect power lead to power source. A power lead adapter may be required.

7. Raise jack stand and remount horizontally on storage bracket.
8. Lower planter to the planting position and check to be sure the hitch is level. If hitch slopes up or down, disconnect planter and adjust hitch clevis up or down as necessary.

MACHINE OPERATION

LEVELING THE PLANTER

For proper performance of the planter and row units, it is important that the planter frame and row unit parallel arms operate approximately level. The toolbar should operate at a 20"-22" height measured from the planting surface to the bottom of the toolbar.

D101602106



Four holes in the hitch bracket allow the clevis to be raised or lowered. In addition, the clevis may be turned over for a finer adjustment between mounting holes. When installing the clevis mounting bolt, make sure the lock nut is tightened to proper torque setting.

D032901180a

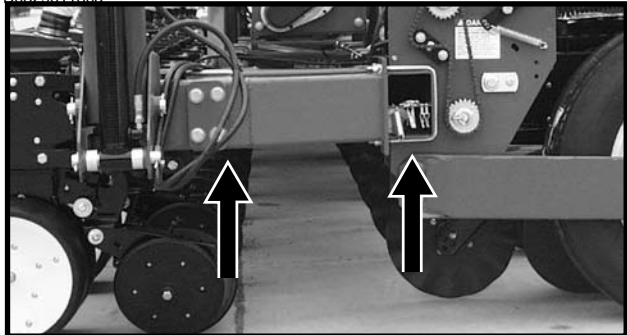

With the planter lowered to operating height, check to be sure the frame is level fore and aft. Recheck once planter is in the field.

It is important for the planter to operate level laterally. Tire pressure must be maintained at pressures specified. See "Tire Pressure".

Field and actual planting conditions will dictate which of the transport wheel settings to use to ensure row unit parallel arms are approximately parallel with the planting surface. It may also be necessary to lower the ground drive wheels to ensure level lateral toolbar operation if the transport wheels are set in one of the two lower sets of holes.

NOTE: To allow adequate drive force after lowering the ground drive wheels, it may be necessary to lower the contact drive wheel arms to the lower sets of holes in the wheel modules and lower the down pressure springs to the lower mounting rods on the wheel modules.

(RU113h)

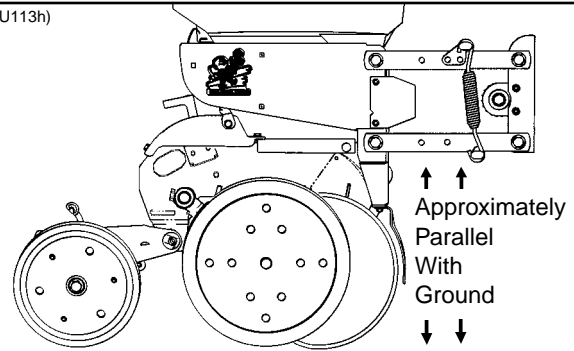

(A10128a)

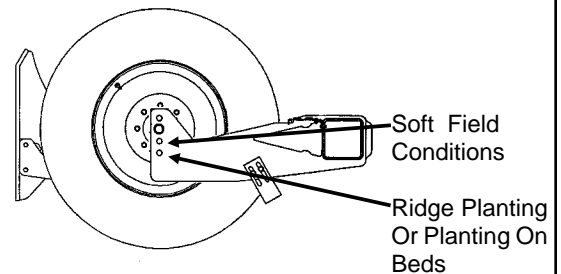

TRANSPORT WHEEL

(TWL73)

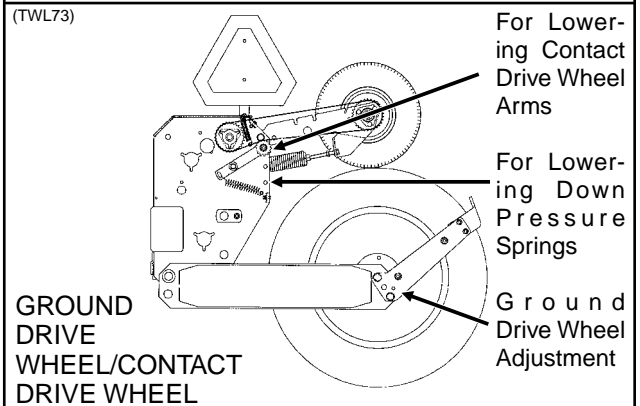

When the planter has been fully loaded with seed, granular chemicals, etc.; a field check should be made to be sure the wings are level with the center frame. If the wings are not level with the center frame, the drive wheels and/or transport wheels can be raised or lowered in the wheel arms to increase or decrease planter toolbar height. Hitch height should be raised accordingly to ensure level operation.

NOTE: As the lift cylinders are port rephasing type, it is necessary for the cylinders to fully retract in order to rephase. Cylinder stops can not be used.

MACHINE OPERATION

NOTE: On planters equipped with push row units and no till coulters, the uplift from the down pressure springs may cause the wings to rise slightly in planting position. The effect may be compounded if static pressure is trapped in the planter's hydraulic lift system which can cause the wing cylinders to extend slightly. Operating the tractor's hydraulic system in the float position or moving the tractor's hydraulic lever to the float position briefly, to relieve the pressure, will help to maintain the proper toolbar height.

CONTACT WHEEL SPRING ADJUSTMENT

D011402101

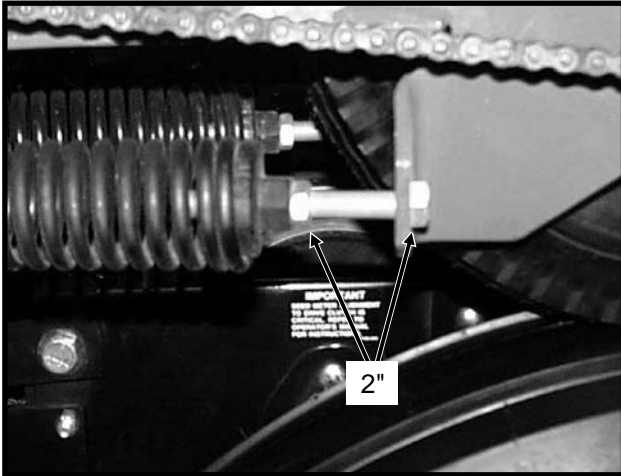

There are two down pressure springs on each contact drive wheel. The spring tension is factory preset and should require no further adjustment.

The tension is set leaving 2" between the spring plug and the bolt head.

TIRE PRESSURE

(TWL279)

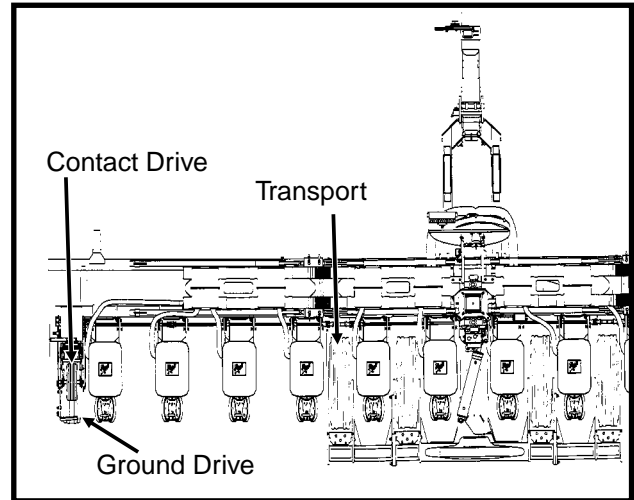

D020904101

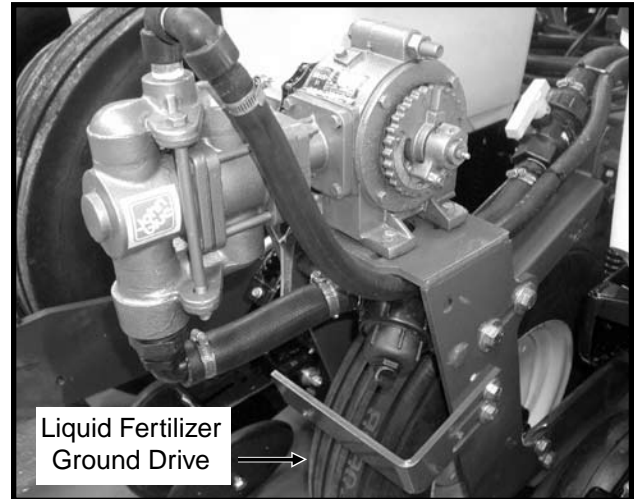

Tire pressure should be checked regularly and maintained as follows:

- 41 x 11R22.5" Transport (Center Section) . . . 75 PSI
- 7.50" x 20" Ground Drive (Wings) 40 PSI
- 4.80" x 8" Contact Drive 50 PSI
- 7.60" x 15" Ground Drive (Liquid Fertilizer Piston Pump) 40 PSI

MACHINE OPERATION

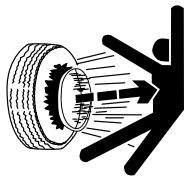

DANGER: Rim and tire servicing can be dangerous. Explosive separation of tire and rim parts can cause serious injury or death.

Do not attempt to mount a tire unless you have the proper equipment and experience to perform the job. This should only be done by persons properly trained and equipped to do the job.

Always maintain the correct tire pressures. Do not inflate the tires above the recommended pressures.

When inflating tires, use a clip-on air chuck and extension hose long enough to allow you to stand to one side and NOT in front of or over the tire assembly. Use a safety cage to enclose the tire and rim assembly when inflating.

Inspect tires and wheels daily. Do not operate with low pressure, cuts, bubbles, damaged rims or missing lug bolts and nuts.

SEED RATE TRANSMISSION ADJUSTMENT

Planting population rate changes are made at each end of the planter. The seed rate transmissions are designed to allow simple, rapid changes of sprockets to obtain the desired planting population. By removing the lynch pins on the hexagon shafts, sprockets can be interchanged with those from the sprocket storage rod bolted near the wheel module on each side of the planter.

Chain tension is controlled by a spring-loaded dual-sprocket idler. The idler assembly is adjusted with a easy-release arm. This arm has a release position to remove spring tension for replacing sprockets. The amount of spring tension on the chain is controlled by the idler arm. See "Wrap Spring Wrench Operation".

A decal positioned on the transmission module illustrates proper chain routing. The planting rate charts found in "Seed Meter Operation/Maintenance" will aid you in selecting the correct sprocket combinations.

D071803317

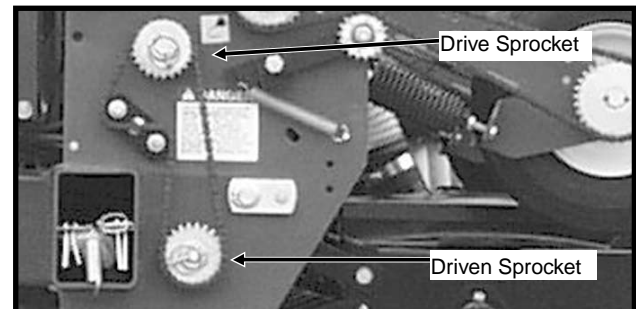

MACHINE OPERATION

CONTACT WHEEL DRIVE SPROCKETS

D070699113a

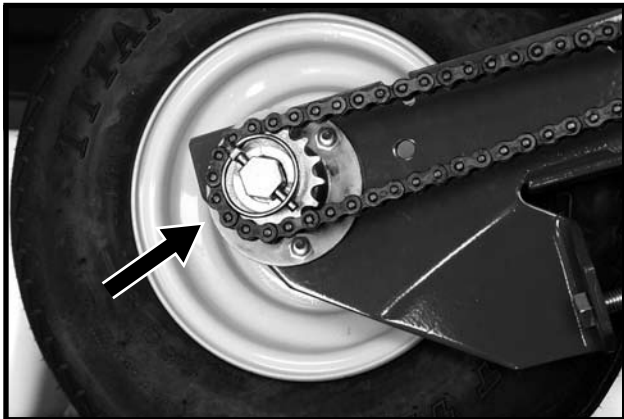

NOTE: 22 tooth, 28 tooth or 44 tooth sprockets at each contact drive wheel can be interchanged from the sprocket storage rod bolted near the wheel module on each side of the planter. 22 tooth sprockets require use of 114 pitch No. 40 chains. 28 tooth sprockets require use of 118 pitch chains. 44 tooth sprockets require use of 126 pitch chains.

Chain tension is controlled by a spring-loaded sprocket idler. The amount of spring tension on the chain is controlled by the idler arm.

The planting rate charts found in Seed Meter Operation/ Maintenance section will aid you in selecting the correct sprocket.

NOTE: 22, 28 and 44 tooth drive sprockets are NOT applicable to all rate charts. Check chart titles to ensure proper rate charts are selected.

NOTE: After each sprocket combination adjustment, make a field test to be sure you are planting at the desired rate.

SHEAR PROTECTION

The planter driveline and seed and granular chemical drivelines are protected from damage by shear pins.

If excessive load should cause a pin to shear, it is important to determine where binding has occurred before replacing the pin. Replace shear pins with same size and type.

Additional shear pins can be found in the storage area located inside the rear planter frame.

To prevent future binding or breakage of components, check driveline alignment and follow prescribed lubrication schedules.

50981-10

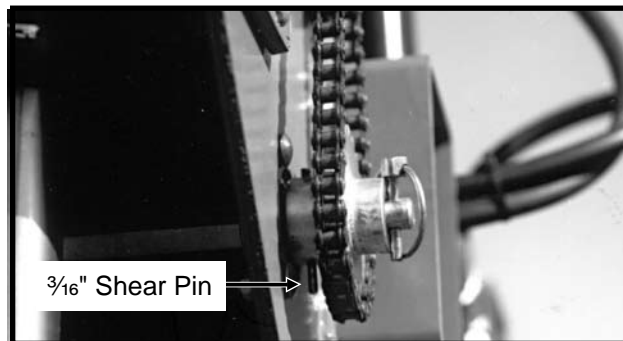

Transmission Shaft

MACHINE OPERATION

WRAP SPRING WRENCH OPERATION

The chain idlers are equipped with wrap spring wrenches. Chain tension is released and/or added as shown below.

To release chain tension, rotate the knurled collar on the wrap spring wrench while rotating the chain idler away from the chain.

D10290305

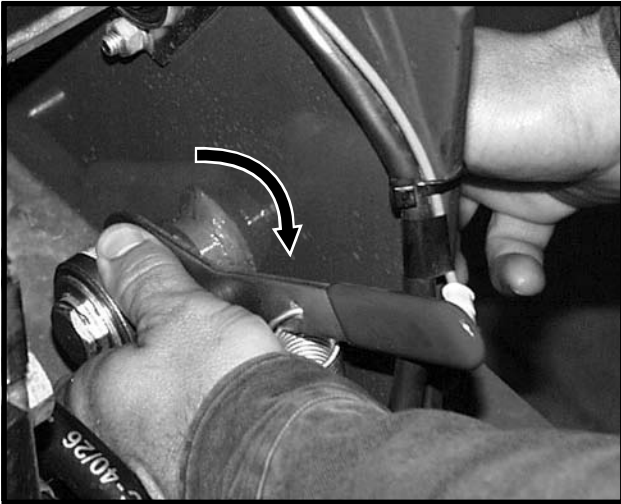

To add chain tension, rotate the chain idler into the chain while rotating the handle to tension idler spring.

D10290304



The wrap spring wrenches are made in L.H. and R.H. configurations, which can be identified by the silver or gold release collars, respectively.

RIDGE PLANTING

When ridge planting, the drive wheels and transport wheels can be lowered 2" or 4" to the lower mounting holes in the wheel arms to increase the planter toolbar height. The contact drive tire must also be lowered to the lower set of holes in the wheel module and the down pressure springs hooked on the lower rod. Hitch height should be raised accordingly to ensure level operation.

(A10128a)

Wheel Shown Mounted In Standard Location - Lower 2" Or 4" To Lower Mounting Holes When Ridge Planting

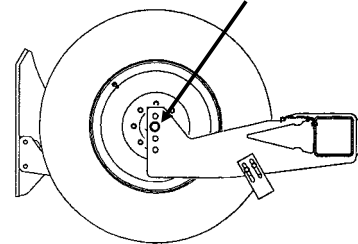

NOTE: The toolbar should operate at a 20"-22" height measured from the bottom of the toolbar to the planting surface.

HYDRAULIC/ELECTRIC OPERATION

76746-24



Conventional Planters

D12160359



Bulk Seed (SDS) Planters

Switches on the control console located on the tractor are used to raise the planter to transport position, operate the rotate and tongue extension functions, lock and release the planter wings, and raise and lower the row markers. The control console for bulk fill planters also monitors auger speed and seed flow.

(Continued On Following Page)

MACHINE OPERATION

! DANGER: To avoid serious injury or death, care must be taken when operating row markers around overhead power lines.

NOTE: The backlit console is equipped with a push button switch on the back of the console which may be used to turn the console face off during extended periods of non-use.

Model 3650 planters are equipped to operate from three dual remote (SCV) hydraulic outlets on conventional planters and four dual remote hydraulic outlets on SDS planters. One SCV, in conjunction with a switch on the control console, is used to operate the raise to transport function. The second SCV, in conjunction with the switches on the control console, is used to operate the markers and fold/unfold functions. The third SCV is for operation of the seed delivery system hydraulic motors on bulk fill planters. One SCV is used to operate the vacuum fan motor circuit.

The marker and point row selector switches are an ON-OFF-ON type.

The raise/wing lock and rotate/tongue (fold function) switches are MOMENTARY ON-OFF-MOMENTARY ON type and must be held in position while operating the tractor hydraulic SCV control. Activating a fold function switch disables the marker circuit.

! WARNING: To ensure the safety of the operator and others nearby, the marker selector switch should be placed in its OFF (center) position when not in use. An indicator light on the control box panel is ON whenever the marker hydraulic circuit or point row clutch electrical circuit are energized.

The auxiliary switch is an ON-OFF type switch which is used in conjunction with the hydraulic marker/folding functions SCV control to operate optional attachments. All 3650 planters are shipped with the auxiliary switch installed in the control console. The auxiliary switch must be in the OFF position to enable other functions.

NOTE: Activating the auxiliary switch disables all other control console switches except the point row clutch switch.

NOTE: The lift cylinders are (port type) rephasing cylinders. It is necessary for all of the lift cylinders to fully retract before they will rephase in the lowered position. Cylinder stops can not be used.

! WARNING: Never work under the planter while in raised position without installing safety lockups.

! WARNING: Make sure all hydraulic hoses are properly connected before operating the planter. Never connect or disconnect hydraulic hoses without first stopping the tractor engine and moving the hydraulic operating controls in both directions to relieve any pressure in the system.

If the planter is equipped with the optional Two-Speed Point Row Clutch Package, the point row switch and reduced rate switch operate independently of the rest of the control console. Power to the marker switch is fed through the auxiliary switch and the two transport function switches. Operating any of the switches in the lower row disables the marker function and turns off the indicator light for the markers.

A7435(TWL81)

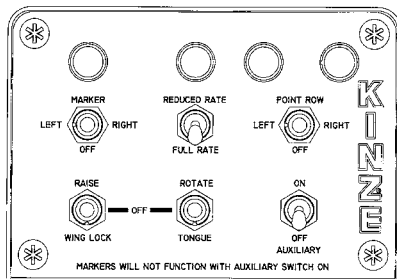

Conventional Planters

(A10189c)

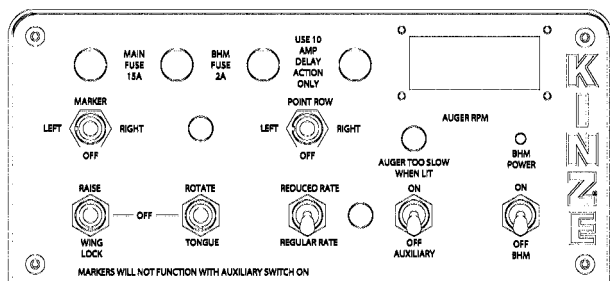

SDS Planters

MACHINE OPERATION

DIGITAL VACUUM GAUGE OPERATION

The digital vacuum gauge console is equipped with an ON-OFF-ON type selector switch. The “FAN 1” setting should be used when the planter is equipped with one vacuum fan.

NOTE: The toggle switch should be left in OFF position when the planter is not in use. If left in either fan position, the tractor battery will be drained.

D10240583



The digital vacuum gauge is calibrated at the factory, however, vacuum will vary throughout the manifold system and it may be necessary to adjust the digital readout so it agrees with the actual vacuum at the meter. With the seed discs loaded with seed, compare the digital vacuum gauge readout to the reading taken from the analog gauge or a hand held gauge at several meters along the length of the planter. The elbows located on the covers of the seed meters allow testing of meter vacuum levels without removing the vacuum hoses. If there is more difference than 1" or 2" (H₂O), the digital gauge can be adjusted by inserting a small flat bladed screwdriver into the opening on the back of the digital gauge housing and turning the potentiometer until the digital gauge displays the vacuum that is present at the meter. Compare readings at 10" and 20" of vacuum.

ANALOG VACUUM GAUGE

The analog vacuum gauge connects directly to the manifold. The digital vacuum gauge should then be calibrated to match that reading. See “Digital Vacuum Gauge Operation”.

D06260653



The only adjustment to the gauge is to “zero” the needle with no vacuum present. If there is a significant difference between this gauge and a reading taken at the meters, a different manifold location should be found to connect hose to the gauge.

VACUUM FAN MOTOR VALVE BLOCK ASSEMBLY

A pressure relief valve in the hydraulic circuit prevents build up of oil pressure over 35 PSI in the case drain line when the vacuum fan motor is in operation. This valve will vent oil to the outside of the valve block, through a drain hole in the aluminum valve block. This can occur whenever the case drain is connected improperly or pressure in the motor circuit builds.

See “Hydraulic Diagram - Vacuum Fan Motor System” in Maintenance section.

The valve block also contains a check valve that serves two purposes. This valve (a) prevents the vacuum fan from operating in the wrong direction if pressure is applied to the return side of the motor and (b) allows the fan to coast to a stop when the tractor hydraulic control is returned to the neutral position.

NOTE: If reverse pressure is applied the fan will turn at a reduced speed.

MACHINE OPERATION

TRANSPORT TO FIELD SEQUENCE

Position the planter in a relatively flat open area. Try to avoid an area with furrows, etc.

SUMMARIZED TRANSPORT TO FIELD SEQUENCE

- Remove tongue safety pin.
- Remove transport latch locking pin.
- Remove manual safety lockup.
- Rotate planter to planting position.
- Lower planter to the ground.
- Release wing lock cylinders.
- Rephase planter lift cylinders.
- Raise planter to raised field position and retract tongue.
- Remove row marker lockups.

NOTE: Read the following information for more detailed instructions.

D071803216



1. With the tongue fully extended and the planter in the raised transport position, remove the tongue safety pin and store it in the storage position.

D071803314



D032901120a



2. Remove the transport latch locking pin from the locked transport position and place it in the storage location.

D032901113

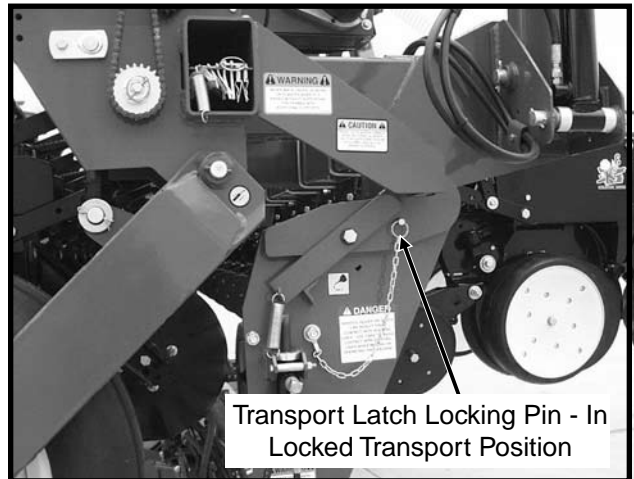

D032901114



MACHINE OPERATION

- Remove the manual safety lockup from under the front center lift cylinder and place it in the storage location on the hose take-up on the planter hitch.

D071603307



LF091903101

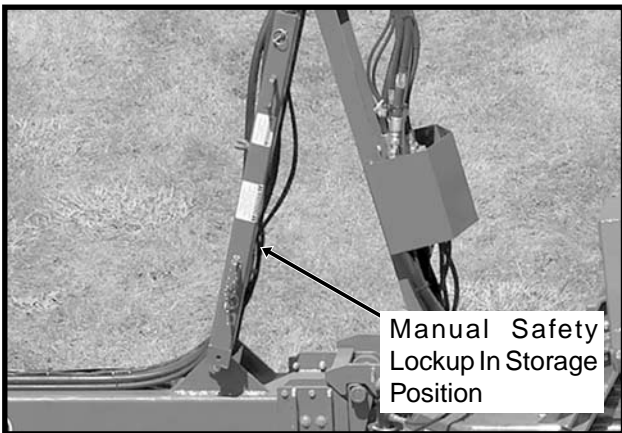

- Hold the control console switch labeled "ROTATE/TONGUE" in "ROTATE" and operate the hydraulic control to unfold the planter. The transport latch will automatically release.

76746-24

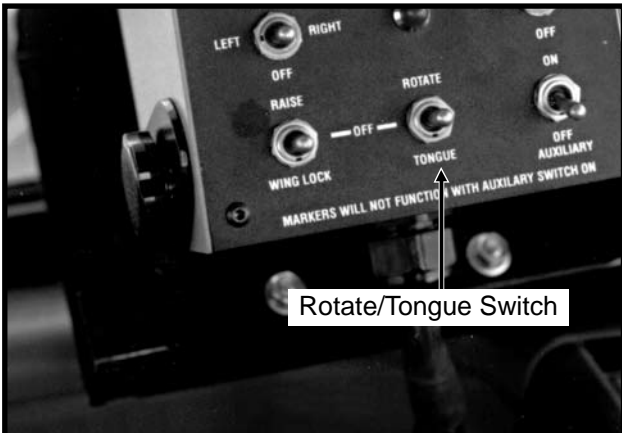

D071803214



Rotate Planter

- Slowly lower the planter to the ground.

D071803210

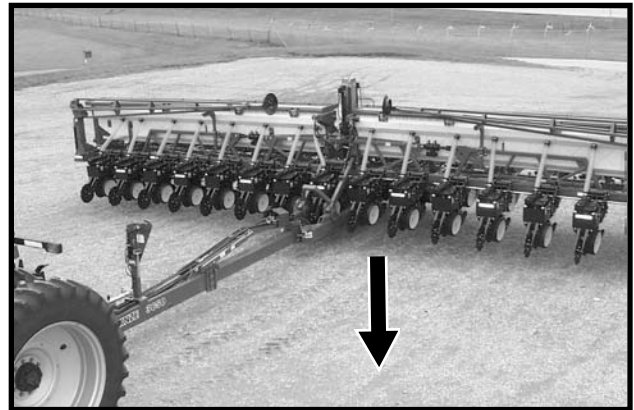

Lower Planter

- Hold the control console switch labeled "RAISE/WING LOCK" in "WING LOCK" position and operate the hydraulic control to extend the wing lock cylinders.

D021102257

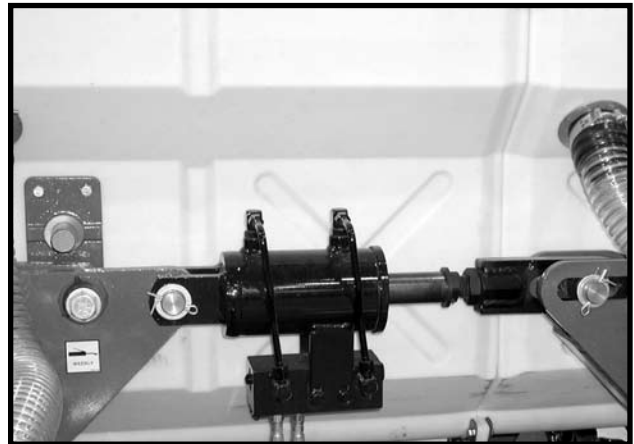

Wing Lock Cylinder With Counter Balance Valve

MACHINE OPERATION

7. Hold the hydraulic lever (to lower planter) to rephase the planter lift cylinders. The length of time it takes to rephase the system may vary due to tractor hydraulic flow and/or oil temperature. Normally 5 to 20 seconds is adequate to rephase the system.
8. Raise the planter to the raised field position. Hold the control console switch labeled "ROTATE/TONGUE" in "TONGUE" and operate the hydraulic lever to retract the tongue.

D071803209

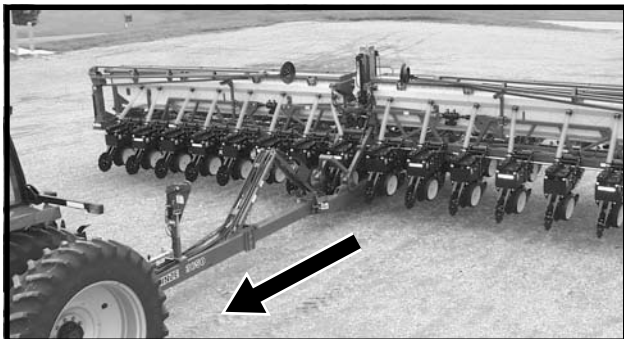

Retract Tongue

9. Remove and store row marker lockups.

D032901130



FIELD OPERATION

There are two raised positions on the planter. One is the "raised field position" which is when the planter wing cylinders are fully extended and the center lift cylinders are at mid-stroke. Because the solenoid, located on the top side of the valve blocks on the rear R.H. side of the center frame, is not energized, the wing cylinders cannot bypass oil preventing the planter from raising any higher. In the "raised field position" the row units are approximately 14 inches off the ground. This position is used in making turns or passing over waterways during field operation. The second raised position is the "raised transport position".

D071803208



Raised Field Position

D071803206

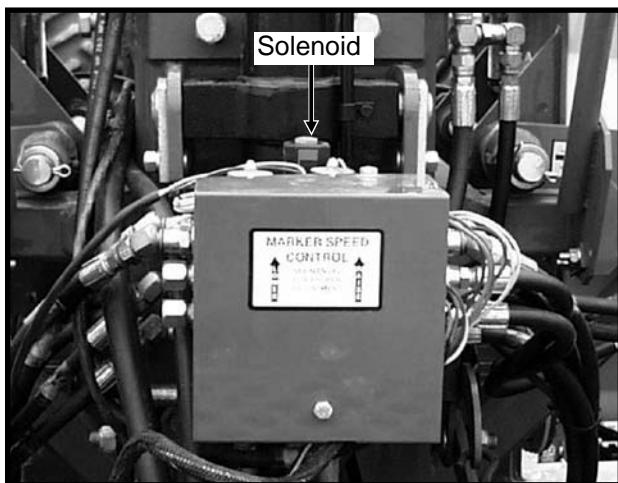

Raise Solenoid

See "Row Marker Operation" for field operation of row markers.

MACHINE OPERATION

FIELD TO TRANSPORT SEQUENCE

Position the planter in a relatively flat area. Try to avoid an area with furrows, etc.

SUMMARIZED FIELD TO TRANSPORT SEQUENCE

- Install row marker lockups.
- Raise planter to raised field position.
- Extend tongue.
- Retract wing lock cylinders.
- Raise planter to raised transport position.
- Rotate planter to transport position.
- Install tongue safety pin.
- Install transport latch locking pin.
- Install manual safety lockup.

NOTE: Read the following information for more detailed instructions.

1. Install row marker lockups.

D032901130



2. Using the hydraulic lever, raise the planter to the raised field position as shown below.

D071803208



Raised Field Position

3. Hold the control console switch labeled “ROTATE/TONGUE” in “TONGUE” and operate the hydraulic control until the tongue is fully extended. Tongue lock latch will automatically release.

D071803209

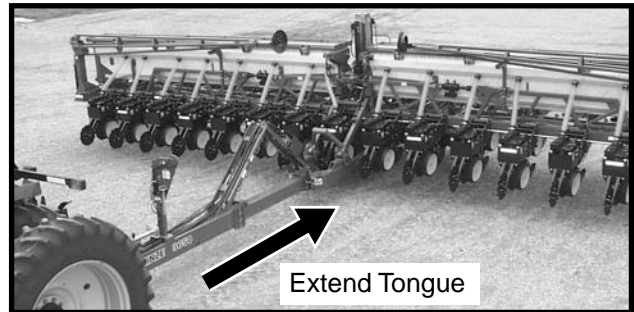

D071603212



4. Hold the control console switch labeled “RAISE/WING LOCK” in “WING LOCK” and operate the hydraulic control until the wing lock cylinders are fully retracted.

76746-24

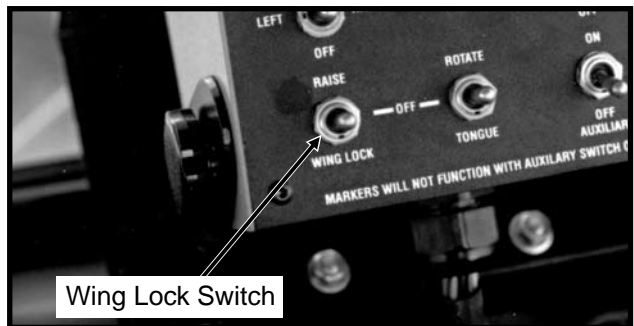

D021102215

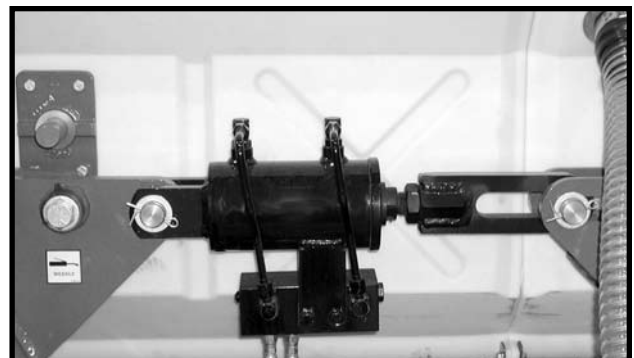

MACHINE OPERATION

5. Hold the control console switch labeled "RAISE/WINGLOCK" in "RAISE" and operate the hydraulic control until the two center lift cylinders are fully extended and the planter is fully raised.

D071803212

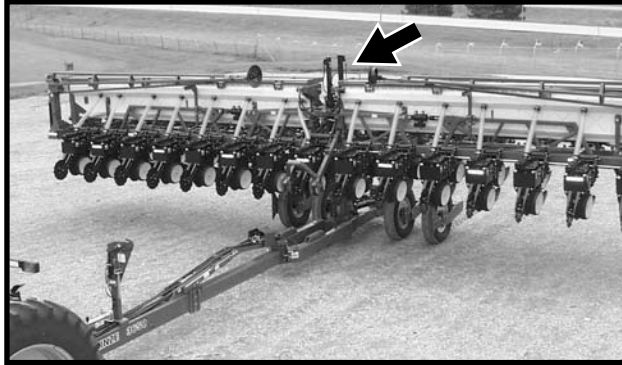

6. Hold the control console switch labeled "ROTATE/TONGUE" in "ROTATE" and operate the hydraulic control to rotate the planter until the transport latch is engaged.

D032901114

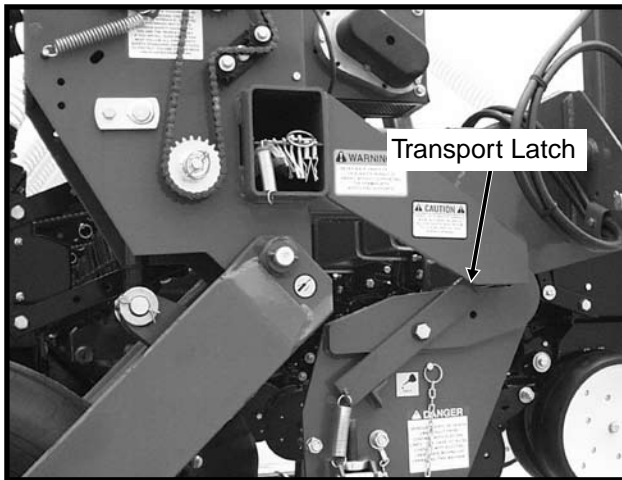

7. Install tongue safety pin.

D071803314



8. Install transport latch locking pin.

D032901113

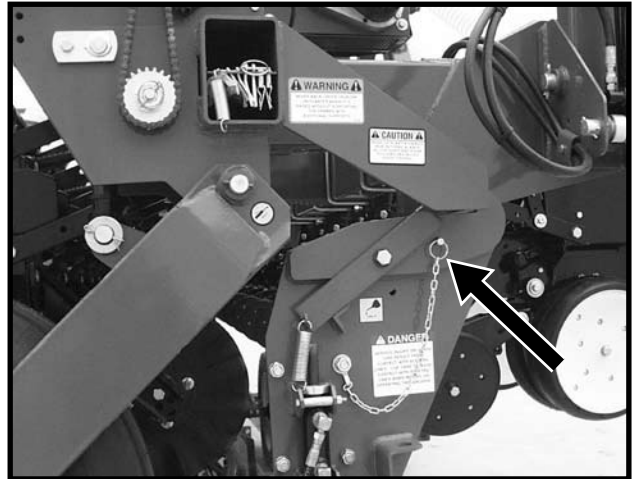

9. Remove manual safety lockup from its storage location on the hose take-up on the planter hitch and position it behind the front center lift cylinder.

LF091903101a

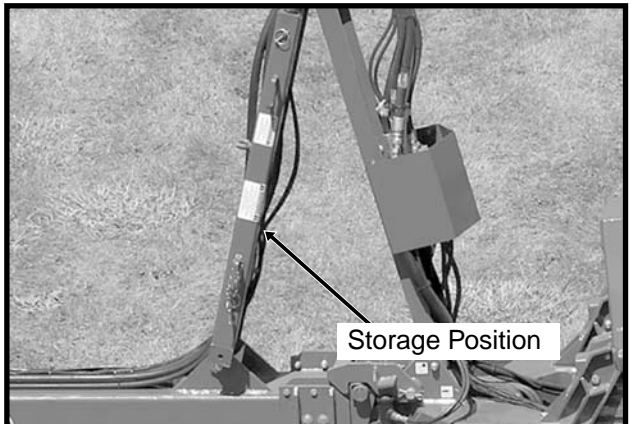

D071603307

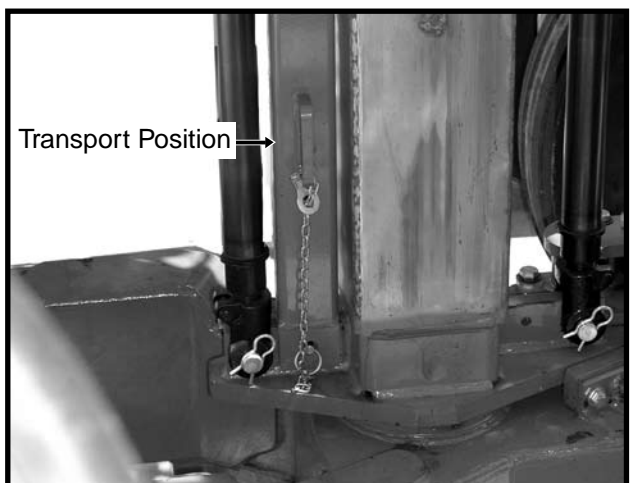

! **DANGER:** Always install the manual safety lockup prior to storage, working under the planter or transporting the planter.

MACHINE OPERATION

ROW MARKER OPERATION

D032901147

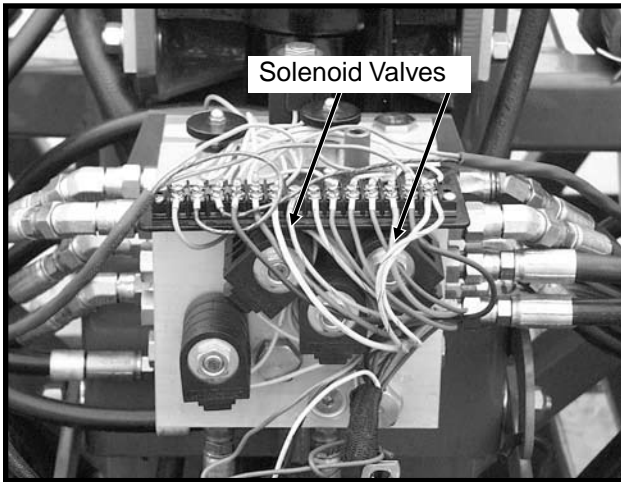

Shown With Cover Removed

D071803206

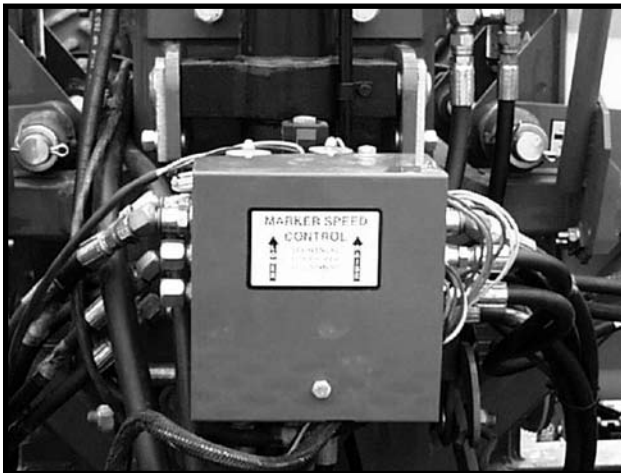

Shown With Cover Installed

76746-24

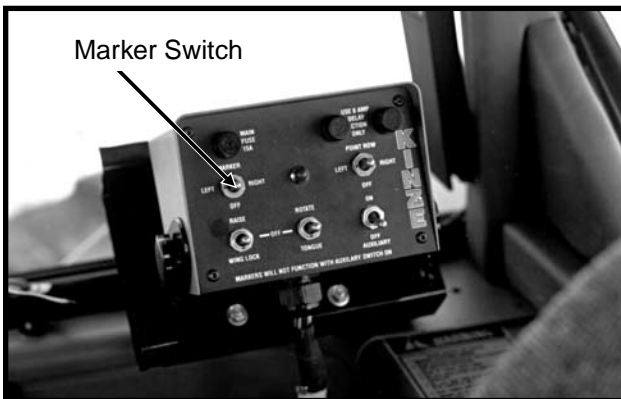

Three Position Selector Switch On Conventional Planter Control Console

D12160359

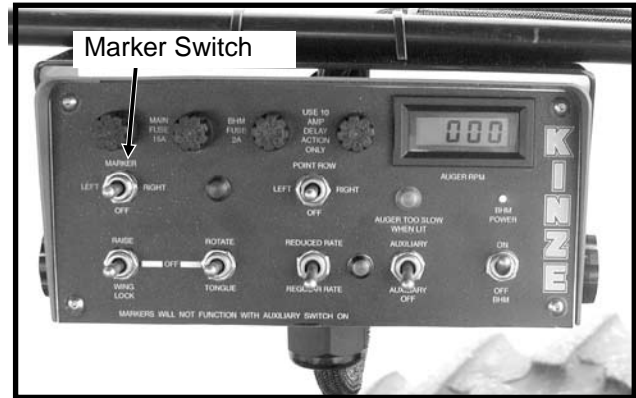

Three Position Selector Switch On SDS Planter Control Console

Two solenoid valves, located on the valve block on the rear R.H. side of the center frame, and a three position selector switch on the control console permit the operator to lower or raise the desired row marker.

See “Row Marker Speed Adjustment”.

1. On the control console, select which marker you want to lower.
2. Operate hydraulic control to lower marker.
3. If opposite marker is to be used next, change control switch to other side.
4. At end of field, using hydraulic control, raise the down marker.
5. After making the turn, using the hydraulic control, lower the pre-selected marker.
6. Continue to follow this procedure.

NOTE: Both markers can be lowered by operating the switch in each position and operating the hydraulic control twice. The markers will raise simultaneously with the hydraulic control in the raise position.

IMPORTANT: Switch should be left in OFF position when planter is not in use. If left in ON position, it will discharge the tractor battery.

If the electrical system fails to operate properly:

- Check fuse.
- Check wiring connections.
- Check control switch.
- Check solenoid. SOLENOID HOUSING WILL BE MAGNETIZED WHEN ENERGIZED.



DANGER: To avoid serious injury or death, care must be taken when operating row markers around overhead power lines.

MACHINE OPERATION

ROW MARKER SPEED ADJUSTMENT

The marker hydraulic system includes two flow control valves. One flow control valve the lowering speed of both markers and one the raising speed of both markers. To adjust marker speed, loosen the jam nut and turn the control(s) clockwise, or IN, to slow the travel speed and counterclockwise, or OUT, to increase the travel speed. The flow control(s) determines the amount of oil flow restriction through the valve(s), therefore varying travel speed of the markers. Tighten jam nut after adjustments are complete.

D071803206

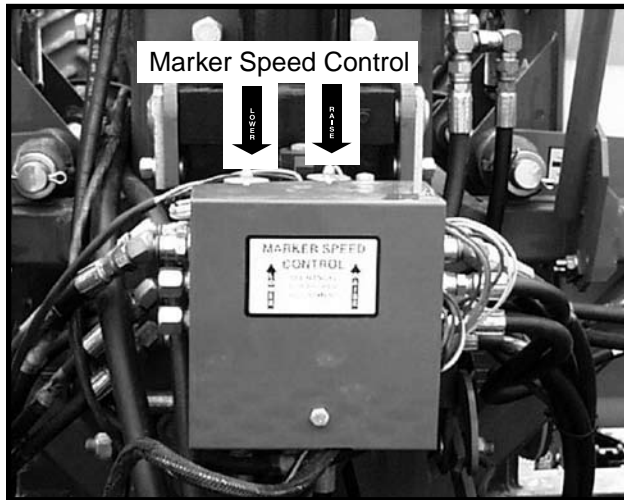

IMPORTANT: The flow controls should be properly adjusted before the marker assembly is first put into use. Excessive travel speed of the markers can damage the marker assembly.

NOTE: When oil is cold, hydraulics operate slowly. Make sure all adjustments are made with warm oil.

NOTE: On a tractor where the oil flow can not be controlled, the rate of flow of oil from the tractor may be greater than the rate at which the marker cylinder can accept the oil. The tractor hydraulic control will have to be held until the cylinder reaches the end of its stroke. This occurs most often on tractors with an open center hydraulic system.

On tractors equipped with flow control valves, marker speed adjustment should be made with the tractor flow controls in maximum position. After marker speed is set, the tractor flow controls can be adjusted to allow the hydraulic control to stay in detent during the marker raise or lower cycle.



DANGER: To avoid serious injury or death, care must be taken when operating row markers around overhead power lines.

ROW MARKER LENGTH ADJUSTMENT

To determine the correct length at which to set the row marker assemblies, multiply the number of rows by the average row spacing in inches. This provides the total planting width. Adjust the marker extension so the distance from the marker disc blade to the center line of the planter is equal to the total planting width previously obtained. Both the planter and row marker assembly should be lowered to the ground when measurements are being taken. The measurement should be taken from the point where the blade contacts the ground. Adjust right and left row marker assemblies equally and securely tighten clamping bolts. An example of marker length adjustment follows:

Number	Row	Dimension Between
Of Rows	x Spacing	= Planter Center Line
	(Inches)	And Marker Disc Blade

12 Rows x 30" Spacing = 360" Marker Dimension or 23 Rows x 15" Spacing = 345" Marker Dimension
--

60569-53

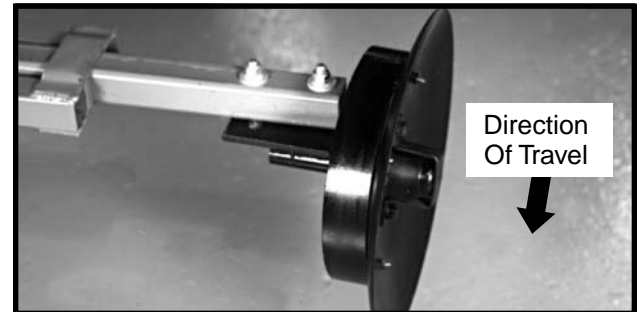

Row Marker Disc Blade Shown With Depth Band.

The marker disc blade should be installed so the concave side of the blade faces outward to throw dirt away from the grease seals. The spindle assembly is slotted so the hub and blade can be angled to throw more or less dirt. To adjust the hub and spindle, loosen the 1/2" hardware and move the assembly as required. Tighten bolts to the specified torque.

IMPORTANT: A marker disc blade assembly that is set at a sharper angle than necessary will add unnecessary stress to the complete row marker assembly and shorten the life of bearings and blades. Set the blade angle only as needed to leave a clear mark.

A field test is recommended to ensure the markers are properly adjusted. After the field test is made, make any minor adjustments as necessary.

Notched marker blades, for use in more severe no till conditions, are available from KINZE® Repair Parts through your KINZE® Dealer.

(Continued On Following Page)

MACHINE OPERATION

When using the even-row push row unit option, adjust marker extensions as shown below.

(TWL280)

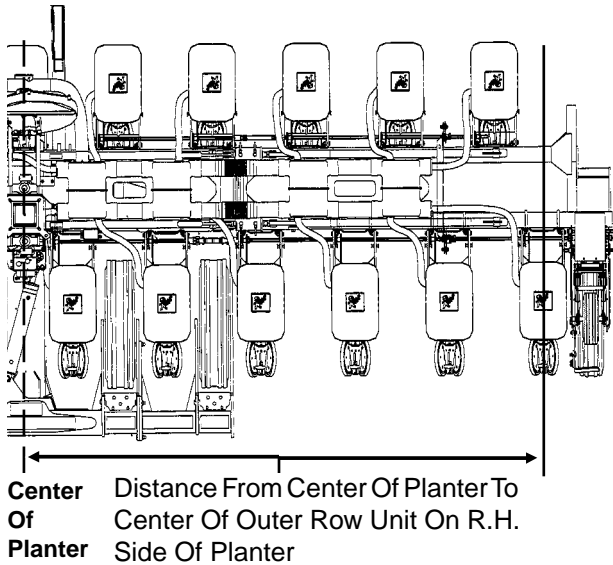
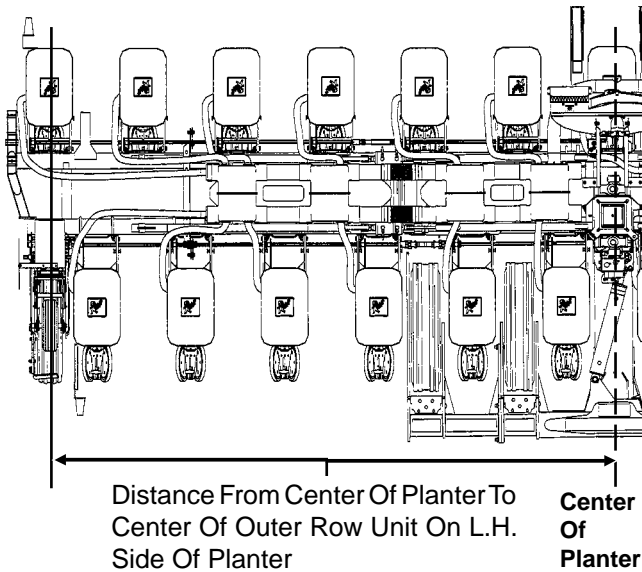

$$\begin{array}{l} \text{Center Of} \\ \text{Planter To} \\ \text{Center Of} \\ \text{Outer Row} \\ \text{Unit} \end{array} \times 2 + \begin{array}{l} 15'' \\ \text{Row} \\ \text{Spacing} \end{array} = \begin{array}{l} \text{Dimension} \\ \text{Between} \\ \text{Planter Center} \\ \text{Line And} \\ \text{Row Marker} \\ \text{Disc Blade} \end{array}$$

12 Row 30" With 12 Interplant® Push Row Units
 (L.H. Row Marker 180" x 2 + 15" = 375")
 (R.H. Row Marker 165" x 2 + 15" = 345")

16 Row 30" With 16 Interplant® Push Row Units
 (L.H. Row Marker 240" x 2 + 15" = 495")
 (R.H. Row Marker 225" x 2 + 15" = 465")

NOTE: If tractor hitch is offset 7 1/2" to the right of the center line of the tractor, add 7 1/2" to the row marker dimension on the R.H. side of the planter and subtract 7 1/2" from the row marker dimension on the L.H. side of the planter.

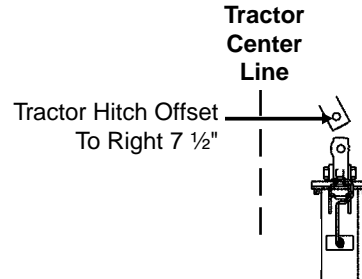

NOTE: Readjust markers when planting 30" rows.

Number Of Rows x Row Spacing (Inches)

=

Dimension Between Planter Center Line And Marker Blade

12 Rows x 30" Spacing = 360" Marker Dimension
 16 Rows x 30" Spacing = 480" Marker Dimension

KPM I ELECTRONIC SEED MONITOR

(MTR28)

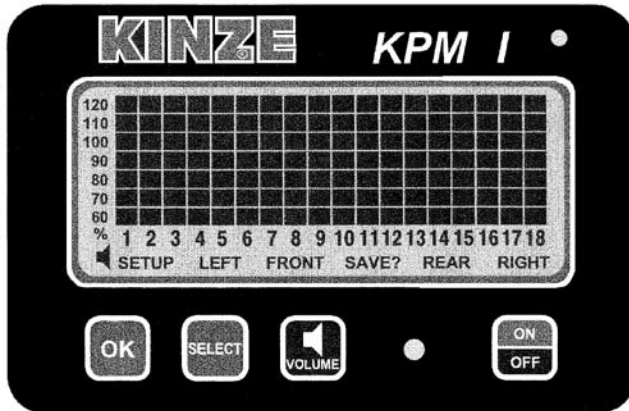

The KPM I electronic seed monitor system consists of a console, which is mounted on the tractor; seed tubes with computerized sensors, one of which is installed in each planter row unit; a primary harness*, which connects the console to the planter harness; and a planter harness (junction Y-harness and/or harness extension where applicable), to which the individual seed tube sensors connect.

Seed flow for up to 36 rows, in two 18 row sections (left/right or rear/front), may be monitored with one monitor. For less complicated applications (18 rows or less), all rows may be programmed in one section and the other section left disabled.

The monitor system is powered by the tractor battery (requires 12 volts DC). The console receives information from each of the sensors and translates this information.

The single backlit Liquid Crystal Display (LCD) shows the active section, the number of monitored rows per section, the relative seed rate for each row (using a bar graph display) and scrolls various alarm and warning messages when an alarm condition exists. A continuous audible alarm will sound upon system malfunction or underflow conditions for any monitored row. Alarms must be acknowledged by the user. Various warnings may sound the alarm or flash one or more icons.

The monitor will power down if no activity is detected within one hour. No activity means there has been no new seed flow and no operator push key input. (If Applicable)

* **NOTE: The primary harness, on all 3000 Series Planters, is hard-wired into the safety/warning light harness or control console harness included as standard equipment with the planter.**

Monitor Key Functions.....	6-21
LCD Functions	6-21
Changing The Audible Alarm Volume	6-22
Warnings And Alarms	6-22
Replacing A Faulty Sensor	6-23
Field Operation	6-24
Programming/Connecting Seed Tubes	6-24

MONITOR KEY FUNCTIONS

Each key press is acknowledged by the monitor with a short beep.

OK

- Ends and saves the new setup during installation.
- Acknowledges and silences alarms in the operation mode.

SELECT

- Selects the application mode (rear/front or left/right) at the beginning of installation setup.
- Selects the active section(s) (rear, rear/front, left, right or left/right) in the operation mode.
- Has no affect on a system configured to monitor only one section.

VOLUME

- Pressing the key will turn the audible alarm on.
- Holding the key for periods of 2 seconds increases the volume until it reaches the maximum, at which time it rolls over to the minimum level.

ON/OFF

- Powers the unit on and off.

LCD FUNCTIONS

The monitor collects data on the planting rates from all active rows and calculates an average. This average will determine the 100% mark. Seed rate for each row is then compared to the average value and the result is displayed on the bar graph.

The information regarding each section is displayed alternately every 5 seconds. While operating a system with two sections programmed, one or both sections may be selected any time. When only one section is selected, the monitor calculates the average based on the remaining active rows from that section.

STEP 1 Press SELECT key once to show one section. The flashing icon shows the section that is not selected. The selected section is continuously displayed on the LCD.

EXAMPLE:The system is setup to display rear/front sections. Press SELECT key. The FRONT icon will be flashing and the REAR section will be displayed on the bar graph. After 1 minute the FRONT icon will stop flashing. The monitor will stay in this REAR only display through power down and power up. Each time the monitor is turned on while in REAR only mode, the FRONT icon will flash for 1 minute. Also if seed flow is sensed in the FRONT section while planting, the FRONT icon will resume flashing.

STEP 2 Press SELECT key again to activate both sections.

EXAMPLE: Press SELECT key a second time. The information regarding each section will display alternately every 5 seconds.

For simple applications, where only one section is programmed, the display will automatically lock on that section. Pressing SELECT key will have no affect.

NOTE:When alternating between two sections, the display will lock on the section containing the first recognized alarm until the alarm is acknowledged by pressing the OK key or the alarm condition is removed.

CHANGING THE AUDIBLE ALARM VOLUME

STEP 1 Press and hold down the VOLUME key.

STEP 2 The SETUP and VOLUME icons will turn on and the alarm will sound continuously. The intensity of the sound will change every 2 seconds. After the maximum volume is reached, the next change will set the volume to minimum and will continue to get louder every 2 seconds. When the desired volume is reached, release the key.

WARNINGS AND ALARMS

1. System Alarms - A system alarm is activated when the monitor detects a faulty sensor or one of several other communication faults.

The corresponding row number starts flashing and the alarm sounds. All segments on the corresponding bar graph are turned off. Pushing the OK key to acknowledge the warning will turn the audible alarm off. The row number will continue to flash until the alarm condition is removed. If the monitor detects a faulty sensor and there is no planting activity present, the monitor will scroll "CHECK CONNECTION".

Another type of system alarm occurs when the monitor detects a data communication bus error. The three possible data communication bus errors are:

LCD Display	Error Condition
SYS HI	The data communication lead (green) has been shorted to the power lead (white).
SYS LO	The data communication lead (green) has been shorted to the ground lead (black).
SYS EC	An internal error has been detected.

2. Under Flow Alarms - If the seed rate for one or more rows is less than 55% of the calculated average, the corresponding 60% segment will stay on, the corresponding row number starts flashing and the alarm sounds. Pushing the OK key to acknowledge the alarm will turn the alarm off. The 60% segment of the bar graph remains on and the row number continues to flash until the alarm condition is corrected.

NOTE: All alarms present within a short time before planting stops, are frozen on the screen and the text LOW or FAIL will display on the LCD. If the under flow is between 0% and 10%, this warrants a "FAIL" condition. If the under flow is between 10% and 55%, a "LOW" condition is generated. If multiple rows have an under flow condition, "FAIL" will display if any one or more rows is between 0% and 10%. This allows the user to identify and fix the problem rows.

NOTE: This warning will not trigger unless a minimum time of continuous planting has passed.

NOTE: If all the rows show a seed rate of zero, the condition will not generate an alarm. It will be assumed the planter has stopped. The row numbers and the bottom 60% segment will remain on for all selected rows.

3. **Multiple Alarms** - If more than one alarm condition occurs at the same time, pushing the OK key will acknowledge all alarms that are currently displayed. For example, if one row on the front and one row on the rear are alarming, pushing the OK key will only acknowledge one of them. However, if there are two alarms on the front, both alarms would be acknowledged with one push of the OK key.
4. **Section Not Selected Warning** - If the monitor was programmed for two sections and only one is currently selected for display (by pressing the SELECT key), the icon of the disabled section will flash for a period of 1 minute, then turn off at each power up. If seed flow is sensed in the disabled section, the icon for that section (front, left or right) will begin to flash.
5. **Seed Planting Stopped Warning** - When the monitor detects no seed flow on all rows, the monitor will emit 3 short beeps to alert the user. This warning will occur each time the planter is stopped, each time the planter is raised at the end of a row or if the mechanical drive fails while planting.

NOTE: This warning will not trigger unless a minimum time of continuous planting has passed.

6. **Seed Counting Sensor In Calibration Warning** - All seed counting sensors run a self-calibration sequence on power up. While in calibration the bottom segment of each corresponding bar graph will flash if the monitor detects movement or planting activity. If the monitor does not detect this, the message "WAIT CALIBRATION" will be scrolled.

7. **Seed Counting Sensor Too Dirty Warning** - After the seed counting sensors end their internal self-calibration, the monitor may detect one or more sensors are either too dirty or blocked. If the monitor detects planting or movement, the corresponding bar graph remains flashing. The monitor will display "CLEAN SENSORS" on the LCD if no movement or planting is detected, prompting the user to clean the tubes. If the tubes are dirty, they will still show seed flow with less accuracy. If the tubes are blocked the user will get an alarm as soon as planting starts. The corresponding bar graph will remain flashing until the problem is corrected and the monitor is powered down and then powered back up.
8. **Low Battery Warning** - The monitor is constantly monitoring its input voltage to quickly detect low power conditions. If the monitor detects that the input voltage has dropped below 11.0V, it will display "LOW POWER" on the LCD, provided that the monitor does not detect planting.

NOTE: After the alarms have been acknowledged and if the alarm condition is still present, the LCD will continue to display the alarm condition.

REPLACING A FAULTY SENSOR

To replace a faulty sensor; (a) disconnect the faulty sensor and check the monitor to be sure the correct sensor was disconnected, (b) turn the monitor off, (c) after a few seconds, turn the monitor back on and (d) plug in the replacement sensor. The monitor will chirp twice to acknowledge the new sensor was learned and saved.

To replace more than one faulty sensor, proceed as stated above beginning with the lowest numbered row in the rear or left section and continue to replace sensors in increasing order. Then move on to the front or right section and continue in ascending row number order.

NOTE: If the monitor is not turned off and then on, the replacement sensor(s) will be ignored until the next power on, at which point they will be randomly learned by the monitor.

FIELD OPERATION

(MTR28e/MTR28c/MTR28d/MTR28b)

Press the ON/OFF key to turn the monitor on and off.



Information regarding each section is displayed alternately every 5 seconds.

REAR/FRONT CONFIGURATION

- Press the SELECT key once to show REAR section only.
- Press the SELECT key a second time to return to each section being displayed alternately every 5 seconds.
- Press the SELECT key a third time to show REAR section only again.



LEFT/RIGHT CONFIGURATION

- Press the SELECT key once to show LEFT section only.
- Press the SELECT key a second time to show RIGHT section only.
- Press the SELECT key a third time to return to each section being displayed alternately every 5 seconds.



NOTE: SELECT key has no function when only a single section is being used.

Press the VOLUME key to increase or decrease volume. See "Changing The Audible Alarm Volume".



Press the OK key to silence alarms. See "Warnings And Alarms".



PROGRAMMING/CONNECTING SEED TUBES

STEP 1 All the seed tubes w/sensors must be disconnected from the harness and the monitor must be off.

STEP 2 Press the ON key. The monitor automatically enters the setup procedure. If the monitor was accidentally powered on with no sensors attached, the user can turn the monitor off at this point and the previous configuration is not lost.

STEP 3 Press the SELECT key. Each time you press the SELECT key the mode will toggle between rear/front and left/right. The selected display will be solid and the configuration not currently selected will be flashing. By default the monitor starts in rear/front mode.

01229910

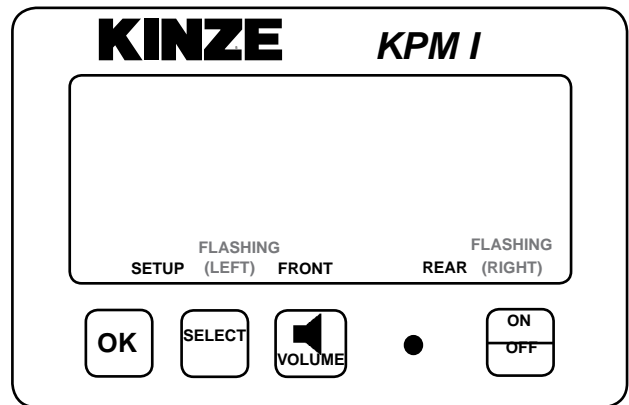

01229911

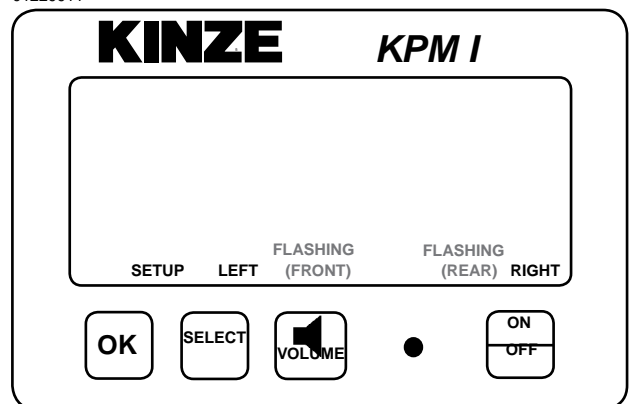

NOTE: Model 3650 planters will use the rear configuration only. When Interplant® Package rows are in use, select the rear/front configurations. When all rows can be viewed on a single display (rear), pressing the select key has no function.

STEP 4 Press and hold the OK key to confirm the selection and continue holding until the row numbers appear on the display. During confirmation, the display will alternate between “NEW” and “SYS” to alert the user that the previous configuration will be lost. With the rear/front mode selected, the monitor automatically starts with the rear section. The REAR icon shows solid and the FRONT icon starts to flash. With the left/right mode selected, the monitor automatically starts with the left section. The LEFT icon shows solid and the RIGHT icon starts to flash.

STEP 5 Plug each seed tube w/sensor into the harness in a predetermined order. Row 1 first, row 2 second and so on up to 18 rows. When a sensor is plugged in, the corresponding row number on the LCD display will stay solid, the monitor will chirp twice and the LED (Light Emitting Diode) on the seed tube sensor will turn on for approximately 30 seconds to show connection is made. NOTE: Unless there is a faulty sensor, the installer should just have to connect the sensors in the proper order without checking the monitor is acknowledging each sensor.

01229912

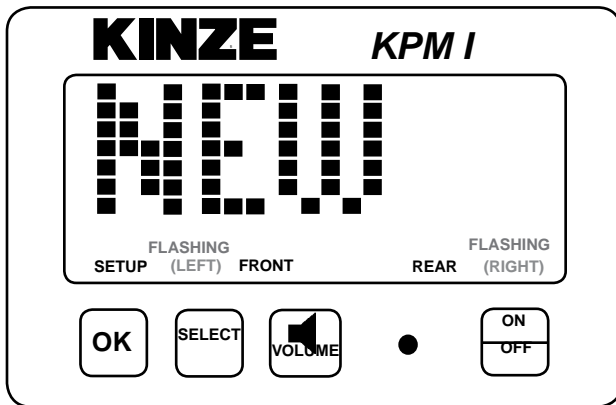

01229915

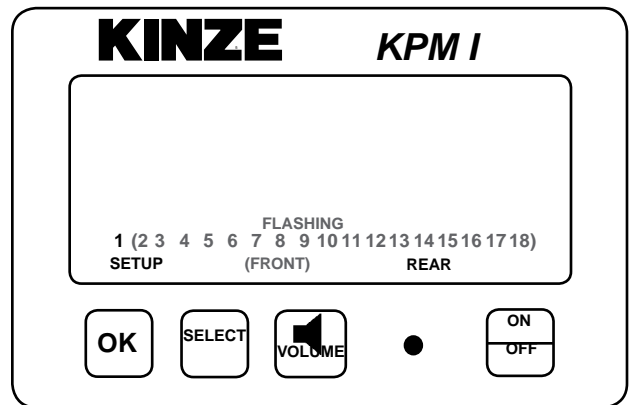

01229912a

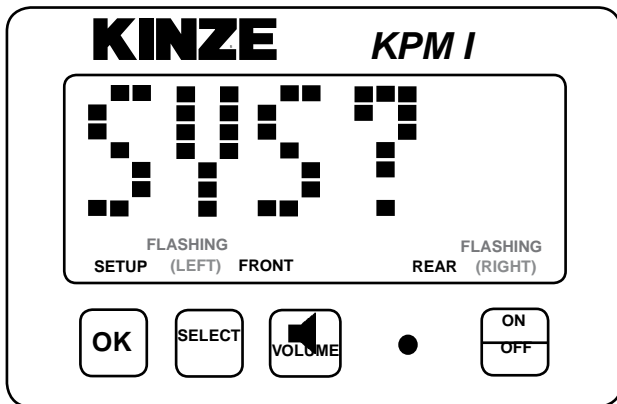

STEP 6 When all the seed tubes w/sensors for the current section are installed, check to be sure the monitor displays solid numbers for the number of sensors connected.

01229916

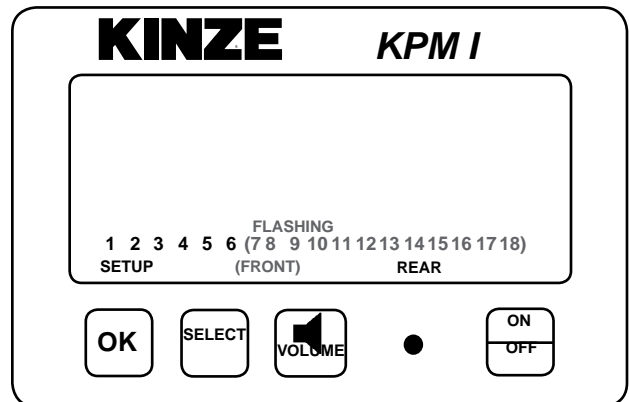

STEP 7 If this condition is satisfied, press and hold the OK key to save the setup for the current section. The SAVE? icon will show followed by continuous short beeps indicating the monitor is preparing to save. The installer has 5 seconds to decide if he wants to save the current configuration. During this time the short beeps will sound. To complete the save, hold the OK key pressed until the word “DONE” shows on the screen followed by a long beep and the SAVE? icon turns off. When the OK key is released the monitor will continue with the second section installation.

STEP 8 Follow STEPS 5 through 7 to install the second section. If no seed tubes are installed on the second section, press and hold the OK key until the word “DONE” shows on the screen followed by a long beep and the SAVE? icon turns off.

01229917

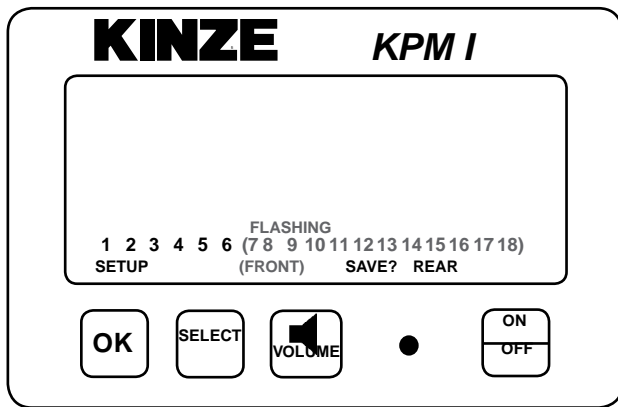

01229919

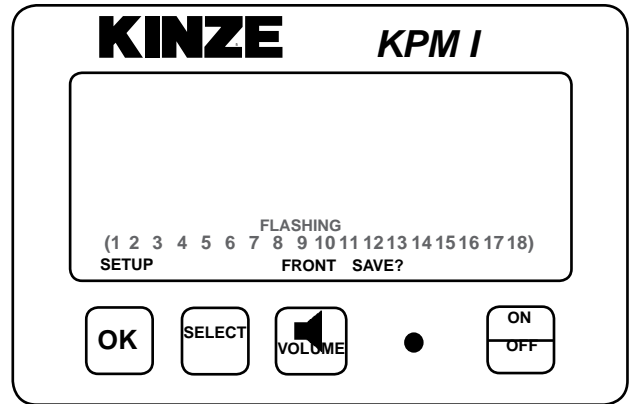

01229920

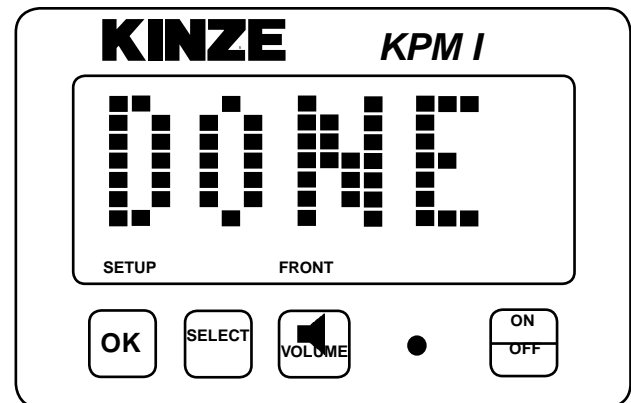

01229918

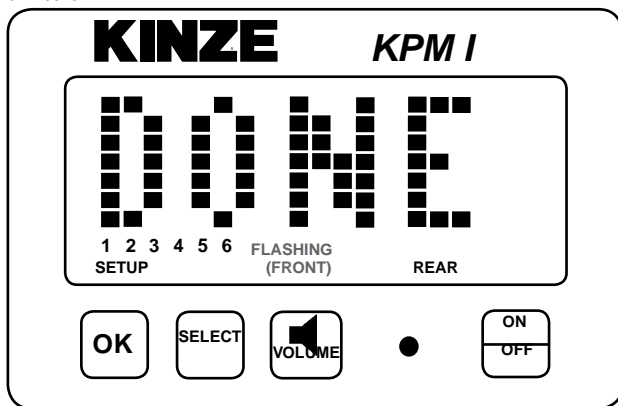

NOTE: Individual seed tubes may be unplugged for special situations. An alarm will sound which can be silenced by touching the OK key. The monitor will recognize each seed tube when reconnected.

See “KPM I/KPM II Stack-Mode Electronic Seed Monitors Troubleshooting” in the Maintenance Section.

KPM II STACK-MODE ELECTRONIC SEED MONITOR

(MTR41e)

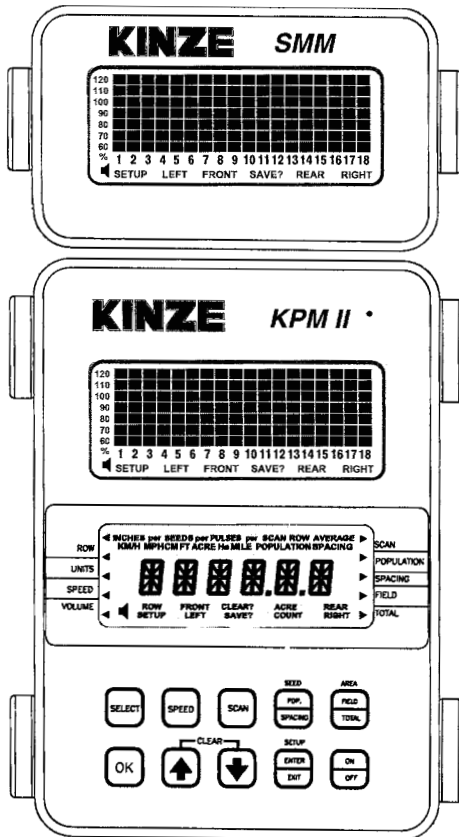

NOTE: SMM console may not be applicable to all models.

The KPM II Stack-Mode electronic seed monitor system consists of (a) a KPM II Stack-Mode console, which is mounted on the tractor; (b) seed tubes with sensors, one of which is installed in each planter row unit; (c) a magnetic distance sensor, which is installed on the planter, or a radar distance sensor, which is installed on the tractor; (d) shaft rotation sensors, which are installed on the planter drill shafts; and (e) a planter harness (junction Y-harness and/or extension harness where applicable), to which the individual seed tube sensors connect. The primary harness, which connects the monitor console to the planter harness, is hard-wired into the safety/warning light harness or control console harness included as standard equipment with the planter.

The software design of the KPM II Stack-Mode console allows the use of an add-on SMM console for simultaneous viewing of the seed flow bar graphs for standard and/or Interplant® System rows (up to 36 rows in two sections). A total of 72 rows may be displayed in multiple sections (rear/front, left/right or four sections). The SMM console must be used to allow utilization of the four section feature.

The SMM console is available as a separate package for use when 3650 planters are equipped with Interplant® Package rows.

The monitor system is powered by the tractor battery (requires 12 volts DC). The console receives information from each of the sensors and translates this information.

The KPM II Stack-Mode console has two backlit Liquid Crystal Displays (LCD). The upper display shows the active section, the number of monitored rows per section, the relative seed rate for each row (using a bar graph display) and scrolls various alarm and warning messages when an alarm condition exists. A continuous audible alarm will sound upon system malfunction or underflow conditions for any monitored row. Alarms must be acknowledged by the user. Various warnings may sound the alarm or flash one or more icons. The lower display is used to display alphanumeric data such as row spacing, units (Metric or English), speed, volume, seed population, seed spacing, field area, total area and distance sensor pulses per mile/kilometer.

The SMM console has one backlit Liquid Crystal Display (LCD) which functions the same as the upper display on the KPM II Stack-Mode console except it does not scroll alarm and warning messages. The SMM console must be programmed into the system before printed text will display on the LCD.

The monitor system will power down if no activity is detected within one hour. No activity means there has been no new seed flow and no operator push key input.

Monitor Key Functions	6-28
Upper LCD Functions	6-29
Lower LCD Functions	6-30
Programming	
Changing The Audible Alarm Volume	6-32
Units (Metric Or English)	6-33
Row Spacing	6-33
Speed	6-35
Clearing Total Area	6-36
Area Counter/Speedometer Mode	6-37
Warnings And Alarms	6-37
Replacing A Faulty Sensor	6-38
Field Operation	6-39
Clearing Field Area	6-40
Programming/Connecting SMM Console, Shaft Rotation Sensors, Seed Tubes And/Or Radar/Magnetic Distance Sensors	6-41
Row-By-Row Alarm Level Setting	6-52

MONITOR KEY FUNCTIONS

Push keys allow the user to select or change the operating mode, the active displays or the current configuration. Depending on the operating mode or the current display selected, some keys are valid while some are not. Each key press, if valid, is acknowledged by a short beep and an action is taken. If the key press has no action associated, the key press is considered invalid, and the user will not get any feedback.

SELECT

- Selects the application mode (rear/front, left/right or four sections up to a maximum of 72 rows) at the beginning of installation in the setup mode.
- Selects the active section(s) (rear, rear/front, left, right or left/right) in the operation mode.
- Has no affect on a system configured to monitor only one section.
- While programming the monitor, the key will select the digit to change.

SPEED

- Immediately displays the current ground speed.

SCAN

- If the current average population or average spacing is displayed, this key sequentially displays the seed population/spacing on each row.
- If the display shows functions other than average seed population or spacing, pressing SCAN will sequentially display speed, average seed population and average seed spacing.
- Pressing a second time freezes the display on the current row.
- Pressing a third time restarts the sequential display.

SEED POPULATION/SEED SPACING

- Immediately displays the average seed POPULATION and the average seed SPACING of all active rows.
- Each press alternates between seed spacing and seed population.

AREA FIELD/AREA TOTAL

- Immediately displays the field or total area planted since the field/total area was last cleared.
- Each press alternates between field area and total area.

OK

- Ends and saves the new setup during installation.
- Acknowledges and silences alarms in the operation mode.

UP ARROW AND DOWN ARROW

- Scrolls sequentially through the display options on the lower LCD display.
- Freezes on the current row in the scan mode.
- Scrolls sequentially through the rows when the population scan is frozen.
- Used to enter programmable values in the programming mode.
- The UP and DOWN Arrow keys can be pressed at the same time to start the CLEAR function.

SETUP ENTER/SETUP EXIT

- Enters and exits the programming mode.

ON/OFF

- Powers the unit on and off.

UPPER LCD FUNCTIONS

(MTR29h)

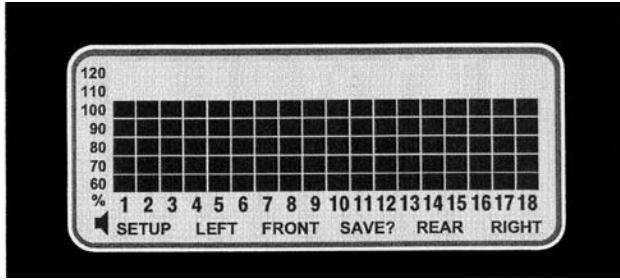

The monitor collects data on the planting rates from all active rows and calculates an average. This average will determine the 100% mark. Seed rate for each row is then compared to the average value and the result is displayed on the bar graph.

With only the KPM II Stack-Mode console programmed into the system, the information regarding each section is displayed alternately every 5 seconds. While operating a system with two sections programmed, one or both sections may be selected any time. When only one section is selected, the monitor calculates the average based on the remaining active rows from that section.

With the SMM console programmed into the system, two sections are viewed at the same time. If the system configuration is for four sections, the display will alternate every 5 seconds between a pair of sections. The select key will lock the display on rear sections. The SMM console shows RIGHT in the left/right configuration, FRONT in the rear/front configuration and FRONT RIGHT/REAR RIGHT in four sections configuration. The KPM II Stack-Mode console shows LEFT in the left/right configuration, REAR in the rear/front configuration and FRONT LEFT/REAR LEFT in four sections configuration.

STEP 1 Press SELECT key once to show one section. The flashing icon shows the section that is not selected. The selected section icon is continuously displayed on the LCD.

EXAMPLE: The system is setup to display rear section on KPM II Stack-Mode console and front section on SMM console. Press SELECT key. The FRONT icon will be flashing and the REAR section will be displayed on the bar graph. The SMM console is only backlit. After 1 minute the front row icon will stop flashing. The monitor will stay in this REAR only display through power down and power up. Each time the monitor is turned on while in REAR only mode, the FRONT icon will flash for 1 minute.

If seed flow is sensed in the FRONT section while planting, the FRONT icon will resume flashing.

When the front section is disabled, the row spacing will automatically double to maintain the proper implement width in the monitor. A 23 or 24 row 15" configuration changes to a 12 row 30" configuration with a touch of the SELECT key.

STEP 2 Press SELECT key again to activate both sections.

For simple applications, where only one section is programmed, the display will automatically lock on that section. Pressing the SELECT key will have no affect.

NOTE: When alternating between two sections, the display will lock on the section containing the first recognized alarm until the alarm is acknowledged by pressing the OK key or the alarm condition is removed.

LOWER LCD FUNCTIONS

(MTR29g)

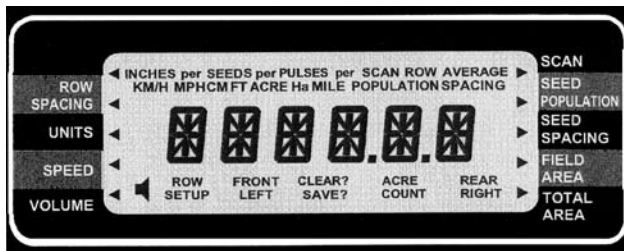

- The UP and DOWN arrow keys will sequentially change what is being displayed on the lower LCD. Pressing the UP or DOWN arrow keys will move the arrow head icon (on the left and right hand side of the display) to another item. For example, if the arrow icon is pointing to SPEED, ground speed will be displayed on the LCD. Pressing the UP arrow key will move the icon to UNITS. The display will change to display all the icons used to represent the current (English or Metric) measurement system.
- The shortcut keys SPEED, SEED POPULATION/SPACING and AREA FIELD/TOTAL allow direct access to their respective displays. For example, no matter what is currently being displayed on the lower LCD, pressing the SPEED key will change the display to the current speed. Pressing the SEED POPULATION/SPACING or AREA FIELD/TOTAL keys will alternate between the two functions assigned to those keys.
- Pressing the SCAN key while displaying seed spacing or population will cause a sequential display of each individual row. Pressing the SCAN key a second time will freeze the display on the currently displayed row. The UP or DOWN arrow keys can be used to change the currently displayed row. Pressing the SCAN key will restart the automatic advancing of the scan function.
- Pressing the SCAN key while displaying speed will cause a sequential display of speed, average planter population and average seed spacing. Pressing the SCAN key a second time will freeze the display on the currently displayed reading.

ROW SPACING

Press the arrow keys to ROW SPACING to display the current spacing between rows in inches or centimeters. The ROW SPACING icons turn on, displaying a 3 digit, one decimal place format. In the area count mode, this function displays the implement width in feet or meters, using a 3 digit, no decimal places format.

UNITS

Press the arrow keys to UNITS to display all the icons from the currently selected English or Metric measurement system. For the English system, the icons are: INCH, MPH, FT, ACRE and MILE. For the Metric system, the icons are: M, KM/H and Ha.

SPEED

Press the SPEED key to display the current speed in MPH or KM/H, using a 3 digit, one decimal place format.

VOLUME

Press the arrow keys to VOLUME to display the presently selected audible alarm volume. The SPEAKER icon turns on.

SCAN

Press the SCAN key to display the seed spacing or seed population (see Steps 1-3 following) of each individual row. (1) Pressing the SCAN key while displaying any other function will cause the monitor to sequentially display speed, average seed population and average seed spacing. (2) Pressing the SCAN key a second time will freeze the display. (3) Pressing the SCAN key a third time restarts the sequential display. The UP and DOWN arrow keys can be used to change the current display.

MACHINE OPERATION

KPM II STACK-MODE

SEED POPULATION/SEED SPACING

Each SEED POP/SPACING key press alternates between seed population and seed spacing.

Seed population displays the average number of seeds or the row average number of seeds per acre or seeds per hectare for all the active rows. The average is displayed using a 6 digits, no decimal places format. The AVERAGE POPULATION icon will turn on. When in the scan mode, the scan arrow and SCAN ROW POPULATION will appear. The ROW number icon and the current row will be displayed on the left and the population will be displayed on the right in 1000's using 3 digits, one decimal place (e.g. 32.9 means 32,900). When in scan freeze mode, the scan arrow and ROW POPULATION will turn on (scan arrow may be flashing). The UP and DOWN keys may be used to lock on the desired row.

Seed spacing displays the average distance or the row average distance between seeds for all active rows in inches per seed or centimeters per seed using a 3 digit, one decimal place format. When the average is displayed the AVERAGE SPACING icons are turned on. When in the scan mode, the scan arrow and SCAN ROW SPACING icons will appear. The ROW number icon and the current row will be displayed on the left and the spacing will be displayed on the right. The display will sequence to the next row every 5 seconds. When in scan freeze mode, the scan arrow and SPACING will turn on (scan arrow may be flashing). The UP and DOWN keys may be used to lock on the desired row.

FIELD AREA/TOTAL AREA

Each AREA FIELD/TOTAL key press alternates between field area and total area.

Field area displays the total number of acres or hectares using a 6 digit, one decimal place format.

NOTE: When FIELD AREA is selected, the UP or DOWN key must be held in slightly longer than normal so the monitor will not mistake this action with a CLEAR, which consists of the UP and DOWN arrow keys pressed simultaneously. A beep will sound when the function activates.

Total area displays the total number of acres or hectares using a 6 digit, one decimal place format. The total area counter updates every time the field area counter increments. Clearing the total area counter will also clear the field area counter.

When the monitor is programmed as a rear only or rear/front configuration and shaft rotation sensors are installed, pressing the UP arrow to move beyond row spacing lights an arrow on an unlabeled area above ROW SPACING. This is the automatically set division line between the L.H. shaft sensor and the R.H. shaft sensor. The display shows the first row on the rear section and the front section assigned to the R.H. shaft rotation sensor.

EXAMPLE: On a 12 Row 30" planter with Interplant® Package, the display would appear as follows:

092597-21

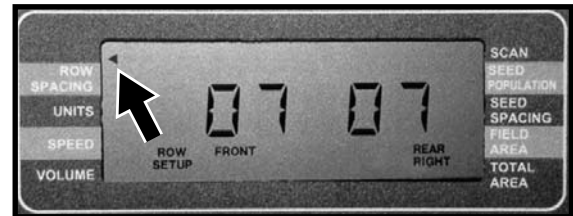

THIS DISPLAY IS NOT ACCESSIBLE ON LEFT/RIGHT CONFIGURATIONS OR SYSTEMS WITHOUT SHAFT ROTATION SENSORS.

PROGRAMMING - Changing The Audible Alarm Volume

STEP 1 To enter the programming mode, press and hold the SETUP key. The monitor will emit several short beeps, followed by a long beep. On the lower LCD, the SETUP icon turns on and the arrow head icon will flash, indicating that the user can select an item to program.

NOTE: The monitor must be in a programmable function (row spacing, units, speed, volume or area) to enter setup. The monitor will not enter setup in seed population or seed spacing.

STEP 2 Press the UP or DOWN arrow keys to move the flashing arrow to VOLUME. As the arrow icon moves, the lower LCD will display the current setting of the item selected.

STEP 3 Press the OK key and the flashing arrow becomes solid and the audible alarm will sound.

NOTE: The lower LCD will display the current volume and the SPEAKER icon is turned on. Settings are from 0 to 9.

- Use the UP or DOWN arrow keys to change the setting. With every UP arrow key push, the alarm will increment by one step between the minimum and the maximum. If the maximum level (9) is reached the volume rolls over to the minimum level (0).
- Pressing the DOWN arrow key lowers the volume until the minimum level (0) is reached, at which point the volume rolls over to the maximum level (9).

STEP 4 To exit without saving, press and release the OK key. The monitor will restore the lower LCD to show the setting of the item, and the arrow icon will flash, allowing the user to select another item to program.

To exit and save, press and hold the OK key. The monitor will emit several short beeps and SAVE? icon is turned on. After a short time a long beep is heard, and the lower LCD will display the word "DONE". Release the OK key. If the OK key is released BEFORE the word "DONE" is displayed, the changes WILL NOT BE SAVED. The word "DONE" MUST be displayed in order for the save to have occurred.

NOTE: The programming mode may be exited at any time, by pressing the SETUP key. Pressing this key will return the monitor to its normal operation. All items changed and saved will come into effect immediately. Any items changed, but not saved will revert to the original programmed value.

MACHINE OPERATION

KPM II STACK-MODE

PROGRAMMING - Units (Metric Or English)

STEP 1 To enter the programming mode, press and hold the SETUP key. The monitor will emit several short beeps, followed by a long beep. On the lower LCD, the SETUP icon turns on and the arrow head icon will flash, indicating that the user can select an item to program.

NOTE: The monitor must be in a programmable function (row spacing, units, speed, volume or area) to enter setup. The monitor will not enter setup in seed population or seed spacing.

STEP 2 Press the UP or DOWN arrow keys to move the flashing arrow to UNITS. As the arrow icon moves, the lower LCD will display the current setting of the item selected.

STEP 3 Press the OK key and the flashing arrow becomes solid and the audible alarm will sound.

NOTE: The lower LCD will alternately display all Metric icons or all English icons, indicating the Metric or English mode respectively.

- Use the UP or DOWN arrow keys to change the setting.

STEP 4 To exit without saving, press and release the OK key. The monitor will restore the lower LCD to show the setting of the item, and the arrow icon will flash, allowing the user to select another item to program.

To exit and save, press and hold the OK key. The monitor will emit several short beeps and SAVE? icon is turned on. After a short time a long beep is heard, and the lower LCD will display the word "DONE". Release the OK key. If the OK key is released BEFORE the word "DONE" is displayed, the changes WILL NOT BE SAVED. The word "DONE" MUST be displayed in order for the save to have occurred.

NOTE: The programming mode may be exited at any time, by pressing the SETUP key. Pressing this key will return the monitor to its normal operation. All items changed and saved will come into effect immediately. Any items changed, but not saved will revert to the original programmed value.

PROGRAMMING - Row Spacing

STEP 1 Prior to entering the programming mode, the application mode (rear/front, left/right or four sections) must be active. If the monitor is programmed in a rear/front configuration, both sections will be active (alternating every 5 seconds if the SMM console is not used). You can then set the row spacing to the Interplant® System row spacing.

EXAMPLE: On a 12 Row 30" with Interplant® Package set the row spacing to 15.0 with front active.

When the monitor is in normal field operation mode, disabling the front section will automatically change the row spacing to 30".

STEP 2 To enter the programming mode, press and hold the SETUP key. The monitor will emit several short beeps, followed by a long beep. On the lower LCD, the SETUP icon turns on and the arrow head icon will flash, indicating that the user can select an item to program.

NOTE: The monitor must be in a programmable function (row spacing, units, speed, volume or area) to enter setup. The monitor will not enter setup in seed population or seed spacing.

STEP 3 Press the UP or DOWN arrow keys to move the flashing arrow to ROW SPACING. As the arrow icon moves, the lower LCD will display the current setting of the item selected.

STEP 4 Press the OK key and the flashing arrow becomes solid and the audible alarm will sound.

NOTE: The lower LCD will display the current row spacing (in inches or centimeters) and ROW SPACING icon is turned on.

- The least significant digit of the displayed value will be blinking.
- This value can be changed by pressing either the UP or DOWN arrow keys.
- Once this digit is correct, press the MODE SELECT key and the blinking digit will move to the next significant digit, where the process can be repeated.

NOTE: The monitor limits the entry of row spacing to a minimum of 10.0 inches (25.4 cm) and to a maximum of 99.9 inches (253.7 cm). If the monitor is configured to a rear/front configuration, the limits change to a minimum of 5.0 inches (12.7 cm) and a maximum of 49.9 inches (126.8 cm).

STEP 5 To exit without saving, press and release the OK key. The monitor will restore the lower LCD to show the setting of the item and the arrow icon will flash, allowing the user to select another item to program.

To exit and save, press and hold the OK key. The monitor will emit several short beeps and SAVE? icon is turned on. After a short time a long beep is heard, and the lower LCD will display the word "DONE". Release the OK key. If the OK key is released BEFORE the word "DONE" is displayed, the changes WILL NOT BE SAVED. The word "DONE" MUST be displayed in order for the save to have occurred.

To exit setup mode, press the SETUP key.

NOTE: The programming mode may be exited at any time, by pressing the SETUP key. Pressing this key will return the monitor to its normal operation. All items changed and saved will come into effect immediately. Any items changed, but not saved will revert to the original programmed value.

MACHINE OPERATION

KPM II STACK-MODE

PROGRAMMING - Speed

STEP 1 To enter the programming mode, press and hold the SETUP key. The monitor will emit several short beeps, followed by a long beep. On the lower LCD, the SETUP icon turns on and the arrow head icon will flash, indicating that the user can select an item to program.

NOTE: The monitor must be in a programmable function (row spacing, units, speed, volume or area) to enter setup. The monitor will not enter setup in seed population or seed spacing.

STEP 2 Press the UP or DOWN arrow keys to move the flashing arrow to SPEED. As the arrow icon moves, the lower LCD will display the current setting of the item selected.

STEP 3 Press the OK key and the flashing arrow becomes solid and the audible alarm will sound. The R.H. digit on the display will be blinking.

The speed constant is used to record how many pulses are generated per mile (or kilometer) from the ground speed sensor. The lower LCD will display the current pulses per mile (or kilometer) using a 6 digit, no decimal place format. The PULSES per MILE (or PULSES per KM) icons are turned on.

NOTE: It is highly recommended that a field calibration be done to establish the PPM/PPKM (Pulses Per Mile/Kilometer) number on a new machine installation. Several factors can affect this value such as wheel slip on the magnetic distance sensor, mounting angle and height on the radar distance sensor, etc. IT IS NOT UNCOMMON FOR THE SPEED ON THE MONITOR TO VARY SLIGHTLY FROM THE TRACTOR SPEEDOMETER. *Adjusting the PPM/PPKM in the monitor to make the speed agree can cause serious errors in acre/hectare and population counts.* Do field checks to verify populations and seed spacings.

NOTE: On new system installations, the monitor will default to 500 PPM (310 PPKM). This will have to be changed to obtain accurate readings from the monitor.

- In field conditions, measure 330 feet ($\frac{1}{16}$ mile) or 100 meters, depending on the unit of measurement selected.

- Pull the tractor up to the starting line.

- Press the UP and DOWN arrow keys at the same time and hold them down until the CLEAR? icon is displayed and the monitor beeps several times. When the data is actually cleared, the monitor will emit a long beep and the number of pulses is cleared.

NOTE: If the PPM/PPKM number starts to count pulses with the tractor not moving, check the radar for vibration or other kinds of interference.

- Drive the tractor for 330 feet ($\frac{1}{16}$ mile) or 100 meters and stop.

- The monitor will count the number of pulses and display them.

STEP 4 To exit without saving, press and release the OK key. The monitor will restore the lower LCD to show the previous setting of the item, and the arrow icon will flash, allowing the user to select another item to program.

To exit and save, press and hold the OK key. The monitor will emit several short beeps and SAVE? icon is turned on. After a short time a long beep is heard, and the lower LCD will display the word "DONE". Release the OK key. If the OK key is released BEFORE the word "DONE" is displayed, the changes WILL NOT BE SAVED. The word "DONE" MUST be displayed in order for the save to have occurred.

NOTE: The programming mode may be exited at any time, by pressing the SETUP key. Pressing this key will return the monitor to its normal operation. All items changed and saved will come into effect immediately. Any items changed, but not saved will revert to the original programmed value.

NOTE: If a discrepancy occurs and digits must be changed, follow STEPS 1 and 2 to enter the programming mode and proceed as follows:

- Press the OK key and the flashing arrow becomes solid. The least significant digit of the displayed value will be blinking.
- This value can be changed by pressing either the UP or DOWN arrow keys.
- Once this digit is correct, press the SELECT key and the blinking digit will move to the next significant digit, where the process can be repeated.

The monitor limits the entry of pulses per mile or kilometer to a minimum of 500 PPM (310 PPKM), and to a maximum of 500,000 PPM (310,686 PPKM).

KEY Action	Flashing Digit	Display Value
Press The UP Key	Right Most Digit	2031, 2032, 2033
Press The SELECT Key	Second Digit From Right	2033
Press The DOWN Key	Second Digit From Right	2023, 2013, 2003, 2093, 2083
Press The SELECT Key Twice	Left Most Digit	2083
Press The DOWN Key	Left Most Digit	1083, 0500 (Min. Value), 9500, 8500

PROGRAMMING - Clearing Total Area

NOTE: Clearing the total area counter will also clear the field area counter.

STEP 1 To enter the programming mode, press and hold the SETUP key. The monitor will emit several short beeps followed by a long beep. On the lower LCD, the SETUP icon turns on and the arrow head icon will flash, indicating that the user can select an item to program.

NOTE: The monitor must be in a programmable function (row spacing, units, speed, volume or area) to enter setup. The monitor will not enter setup in seed population or seed spacing.

STEP 2 Press the UP or DOWN arrow keys to move the flashing arrow to TOTAL AREA. As the arrow icon moves, the lower LCD will display the current setting of the item selected.

STEP 3 Press the OK key and the flashing arrow becomes solid and the audible alarm will sound.

- The lower LCD will display the total area and the ACRE (or Ha) icon turns on.
- With the flashing arrow on TOTAL AREA, press the OK key.

• To reset the counter, press the UP and DOWN arrow keys at the same time and hold them down for a short period of time to clear the data. The CLEAR? icon will be displayed and the monitor will beep several times. When the data is actually cleared, the monitor will emit a long beep, and the total area is reset to zeros. After the long beep, the previous recorded total area is not retrievable. Once cleared, the user **may not** choose to exit programming mode without saving as described in STEP 4.

STEP 4 To exit and save, press and hold the OK key. The monitor will emit several short beeps and SAVE? icon is turned on. After a short time a long beep is heard, and the lower LCD will display the word "DONE". Release the OK key. If the OK key is released BEFORE the word "DONE" is displayed, the changes WILL NOT BE SAVED. The word "DONE" MUST be displayed in order for the save to have occurred.

NOTE: The programming mode may be exited at any time, by pressing the SETUP key. Pressing this key will return the monitor to its normal operation. All items changed and saved will come into effect immediately. Any items changed, but not saved will revert to the original programmed value.

MACHINE OPERATION

KPM II STACK-MODE

AREA COUNTER/SPEEDOMETER MODE

If the monitor is installed with only a radar distance sensor (no seed tubes attached), the monitor becomes a speedometer. If (a) the monitor is connected to a radar distance sensor, (b) the signal cable from the back of the console is connected to a sensing switch (Part No. G1K249 Acre Counter Switch Kit) instead of the seed tubes and (c) the implement width in feet (or meters) is programmed into the monitor, the monitor will function as an area counter.

The seed spacing and seed population functions are not available in this mode. If the monitor is powered down, the seed tubes connected and the monitor powered up, the monitor will again show seed population and seed spacing in inches or centimeters. Row spacing reverts back to its programmed setting.

WARNINGS AND ALARMS

- System Alarms** - A system alarm is activated when the monitor detects a faulty sensor or one of several other communication faults.

The corresponding row number starts flashing and the audible alarm sounds. All segments on the corresponding bar graph are turned off. Pushing the OK key to acknowledge the warning will turn the alarm off. The row number will continue to flash until the alarm condition is removed. If the monitor detects a faulty sensor and there is no planting activity present, the monitor will scroll "CHECK CONNECTION".

If the distance sensor is detected as faulty, the monitor will display either "PICKUP" or "RADAR", depending on the type of sensor installed, and the audible alarm will sound. The user can push the OK key to acknowledge the alarm. When the distance sensor is faulty, the monitor will change to a bar graph only mode where the rows are still displayed relative to each other. No area related information (speed, field area, total area, seed spacing or seed population) will be accumulated or displayed.

If a rotation shaft sensor is faulty, "LSHAFT", "RSHAFT" or "SHAFTS" will display.

Another type of system alarm occurs when the monitor detects a data communication bus error.

The four possible data communication bus errors are:

LCD Display	Error Condition
SYS HI	The data communication lead (green) has been shorted to the power lead (white).
SYS LO	The data communication lead (green) has been shorted to the ground lead (black).
SYS EC	An internal error has been detected.
COP	Cycled power ON/OFF to quickly.

- Under Flow Alarms** - If the seed rate for one or more rows is less than 55% of the calculated average, the corresponding 60% segment will stay on, the corresponding row number starts flashing and the alarm sounds. Pushing the OK key to acknowledge the warning will turn the alarm off. The 60% segment of the bar graph remains on and the row number continues to flash until the alarm condition is corrected.

NOTE: All alarms present within a short time before planting stops are frozen on the screen and the text LOW or FAIL will display on the LCD. If the under flow is between 0% and 10%, this warrants a "FAIL" condition. If the under flow is between 10% and 55%, a "LOW" condition is generated. If multiple rows have an under flow condition, "FAIL" will display if any one or more rows is between 0% and 10%. This allows the user to identify and fix the problem rows.

NOTE: This warning will not trigger unless a minimum time of continuous planting has passed.

NOTE: If all the rows show a seed rate of zero, the condition will not generate an alarm. It will be assumed the planter has stopped. The row numbers and the bottom 60% segment will remain on for all selected rows.

- Multiple Alarms** - If more than one alarm condition occurs at the same time, pushing the OK key will acknowledge all alarms that are currently displayed. For example, if one row on the front and one row on the rear are alarming, pushing the OK key will only acknowledge one of them. However, if there are two alarms on the front, both alarms would be acknowledged with one push of the OK key.

4. **Section Not Selected Warning** - If the monitor was programmed for two sections and only one is currently selected for display (by pressing the SELECT key), the icon of the disabled section will flash for a period of 1 minute, then turn off at each power up. If seed flow is sensed in the disabled section, the icon for that section (front, left or right) will begin to flash.
5. **Seed Planting Stopped Warning** - When the monitor detects no seed flow on all rows, the monitor will emit 3 short beeps to alert the user. This warning will occur each time the planter is stopped, each time the planter is raised at the end of a row or if the mechanical drive fails while planting.

NOTE: This warning will not trigger unless a minimum time of continuous planting has passed.

6. **Seed Counting Sensor In Calibration Warning** - All seed counting sensors run a self-calibration sequence on power up. While in calibration the bottom segment of each corresponding bar graph will flash if the monitor detects movement or planting activity. If the monitor does not detect this, the message "WAIT CALIBRATION" will be scrolled.
7. **Seed Counting Sensor Too Dirty Warning** - After the seed counting sensors end their internal self-calibration, the monitor may detect one or more sensors are either too dirty or blocked. If the monitor detects planting or movement, the corresponding bar graph remains flashing. The monitor will display "CLEAN SENSORS" on the top LCD if no movement or planting is detected, prompting the user to clean the tubes. If the tubes are dirty, they will still show seed flow with less accuracy. If the tubes are blocked the user will get an alarm as soon as planting starts. The corresponding bar graph will remain flashing until the problem is corrected and the monitor is powered down and then powered back up.
8. **Low Battery Warning** - The monitor is constantly monitoring its input voltage to quickly detect low power conditions. If the monitor detects that the input voltage has dropped below 11.0V, it will display "LO SYS" on the lower LCD on the KPM II Stack-Mode console, provided that the monitor does not detect speed or planting.

NOTE: After the alarms have been acknowledged and if the alarm condition is still present, the LCD will continue to display the alarm condition.

REPLACING A FAULTY SENSOR

NOTE: Stack-Mode Seed Sensors are identified by a blue 3-pin connector. Replace Stack-Mode Seed Sensors with like components only.

To replace a faulty sensor; (a) disconnect the faulty sensor and check the monitor to be sure the correct sensor was disconnected, (b) turn the monitor off, (c) after a few seconds, turn the monitor back on and (d) plug in the replacement sensor. The monitor will chirp twice to acknowledge the new sensor was learned and saved.

To replace more than one faulty sensor, proceed as stated above for rear/front or left/right configurations beginning with the lowest numbered row in the rear or left section and continue to replace sensors in ascending order. Then move on to the front or right section and continue in ascending order. For four section configurations, begin with rear/left and continue to rear/right, then front/left and ending with front/right.

If the monitor detects a faulty distance sensor, the lower LCD will immediately move to the speed display, show the word "PICKUP" or "RADAR" depending on the distance sensor installed, and the alarm will sound.

NOTE: If the monitor is not turned off and then on, the replacement sensor(s) will be ignored until the next power on, at which point the sensors will be randomly learned by the monitor.

MACHINE OPERATION

KPM II STACK-MODE

FIELD OPERATION

Press the ON/OFF key to turn the monitor on.



Information regarding each section is displayed alternately every 5 seconds.

REAR/FRONT CONFIGURATION (Without SMM Console Installed)

- Press the SELECT key once to show REAR section only. (Monitor sets correct row spacing.)
- Press the SELECT key a second time to return to each section being displayed alternately every 5 seconds on KPM II Stack-Mode console. (Monitor sets correct row spacing.)
- Press the SELECT key a third time to show REAR section only again.



REAR/FRONT CONFIGURATION (With SMM Console Installed)

- Press the SELECT key once to show REAR section only on KPM II Stack-Mode console. (Monitor sets correct row spacing.)
- Press the SELECT key a second time to show FRONT section on SMM console and REAR section on KPM II Stack-Mode console. (Monitor sets correct row spacing.)
- Press the SELECT key a third time to show REAR section only again.



FOUR SECTION CONFIGURATION (With SMM Console Installed)

- Press the SELECT key once to show REAR and LEFT sections on KPM II Stack-Mode console and REAR and RIGHT sections on SMM console. (Monitor sets correct row spacing.)
- Press the SELECT key a second time to return to all four sections, alternating right front and right rear on SMM console and alternating left front and left rear on KPM II Stack-Mode console. (Monitor sets correct row spacing.)
- Press the SELECT key a third time to show REAR and LEFT sections on KPM II Stack-Mode console and REAR and RIGHT sections on SMM console again.



NOTE: SELECT key has no function when only a single section is being used.

At power up, the lower LCD will show speed (MPH or KM/H).

(MTR29g/MTR29b/MTR29a/MTR29c/MTR29f/MTR29c/MTR29f)

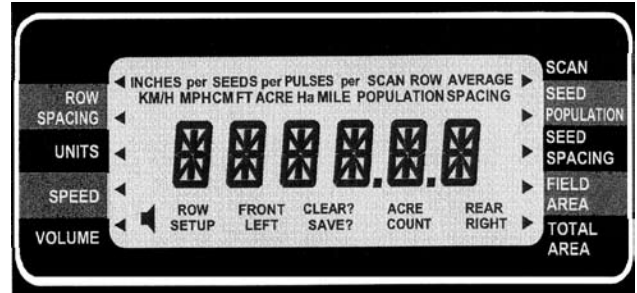

Press the UP or DOWN arrow keys to move the flashing arrow on the lower LCD to change what is displayed on the lower LCD.



Press the shortcut keys SPEED, SEED POPULATION/SEED SPACING or AREA FIELD/TOTAL for direct access to these displays.



(MTR29c/MTR29d/MTR29b/MTR29c)

Press the SEED POPULATION/SEED SPACING or AREA FIELD/TOTAL keys to alternate between the two functions assigned to that key.



Press the SEED POPULATION/SEED SPACING key to choose average seed spacing/population per acre.



Press the SCAN key to display individual rows starting at row 1.

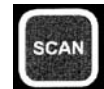

Press the SCAN key again to lock on current row.

Press the SCAN key again to resume scrolling.

Use the UP or DOWN arrow keys to move to a particular row.



Press the SEED POPULATION/SEED SPACING key to go back to planter average.



CLEARING FIELD AREA

(MTR29n/MTR28b)

To reset the counter, press the UP or DOWN arrow keys to move the arrow in the lower display to FIELD AREA.



Press the UP and DOWN arrow keys at the same time and hold them down for a short period of time to clear the data. The CLEAR? icon will be displayed and the monitor will beep several times. When the data is actually cleared, the monitor will emit a long beep, and the field area is reset to zero. After the long beep, the previous field area recorded is not retrievable.



NOTE: Clearing the field area counter will not clear the total area counter. See “Programming-Clearing Total Area” for clearing total area.

Press the OK key to silence alarms. See “Warnings And Alarms”.



MACHINE OPERATION

KPM II STACK-MODE

PROGRAMMING/CONNECTING SMM CONSOLE, SHAFT ROTATION SENSORS, SEED TUBES AND/OR RADAR/MAGNETIC DISTANCE SENSORS

STEP 1 All sensors (including the seed tubes w/ sensors, radar, magnetic distance, SMM console and shaft rotation sensors) must be unplugged from the harness and/or console and the monitor must be off.

NOTE: If the monitor detects a radar sensor but no seed tubes at power up, it will automatically go into AREA COUNT mode. See “Area Counter/Speedometer Mode”.

NOTE: Disconnect magnetic distance sensor between MDS adapter and planter harness. DO NOT disconnect between MDS and MDS adapter.

01189909

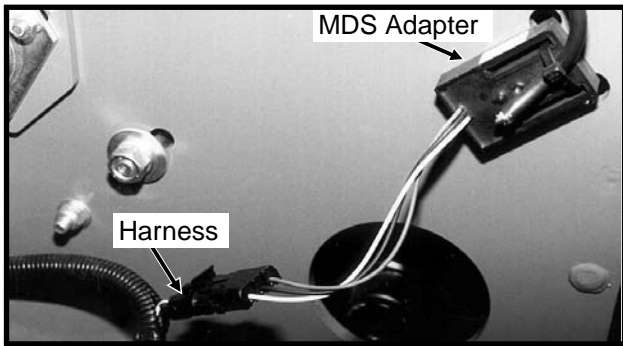

01189910



STEP 2 Press the ON key. The monitor automatically enters the setup procedure. Monitor will scroll “NO SENSOR” on top LCD of KPM II Stack-Mode console.

STEP 3 The monitor automatically defaults to rear/front. Press the SELECT key once for left/right and twice for four sections (front right/front left/rear right/rear left). The selected display will be solid and the configuration not currently selected will be flashing.

12060211

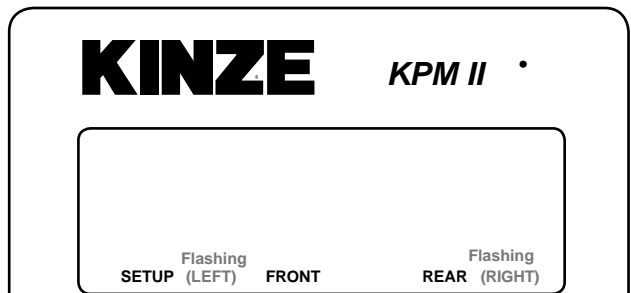

ROW	SETUP	SCAN
UNITS		SEED
SPEED		SEED
VOLUME		FIELD
		TOTAL

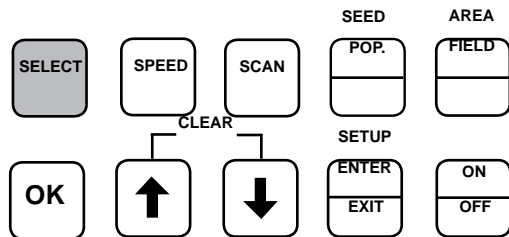

NOTE: SMM console may not be applicable to all models.

MACHINE OPERATION

KPM II STACK-MODE

12060211

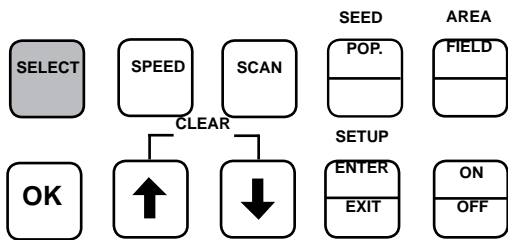
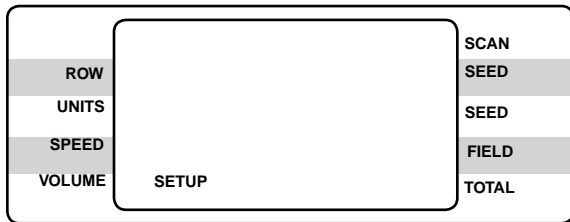
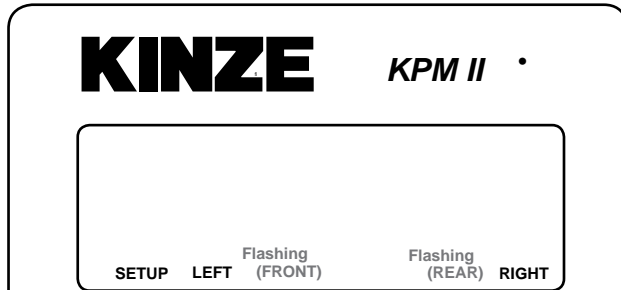

NOTE: SMM console may not be applicable to all models.

NOTE: Model 3650 planters select the rear configuration only. When Interplant® Package rows are in use, select the rear/front configuration.

STEP 4 Press and hold the OK key to confirm selection. The upper display will alternate between “NEW” and “SYS?”.

The alarm will sound four short beeps followed by one long beep. At this point your selection has been saved and row numbers will appear flashing on the upper display.

12060211

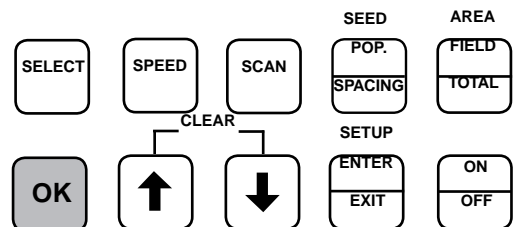
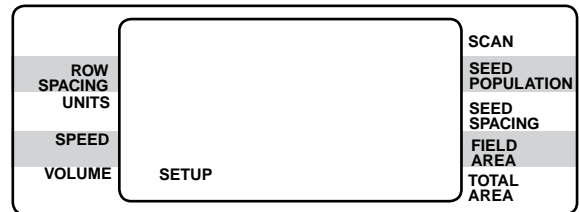
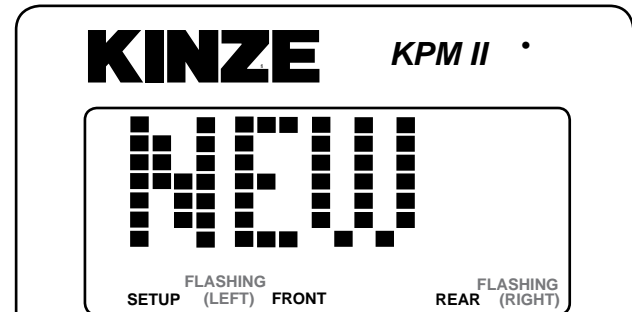
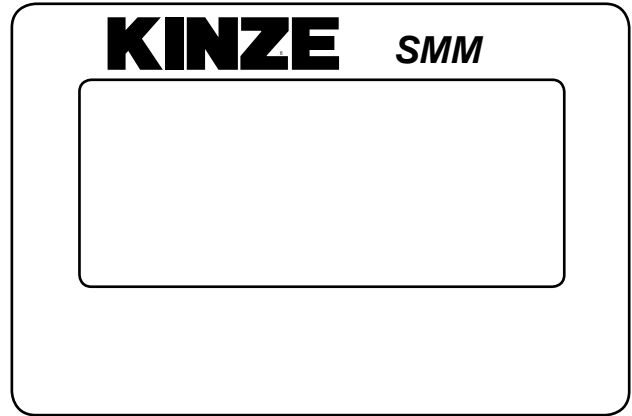

NOTE: SMM console may not be applicable to all models.

MACHINE OPERATION

KPM II STACK-MODE

NOTE: Illustrated using rear/front configuration. The KPM II Stack-Mode console shows LEFT in the left/right configuration, REAR in the rear/front configuration and FRONT LEFT/REAR LEFT in the four sections configuration.

STEP 5 (If Applicable) Connect SMM console into junction Y-harness which was installed between the KPM II Stack-Mode console and the primary harness. The SMM console will show a lighted screen and KPM will show on the lower LCD.

12060211

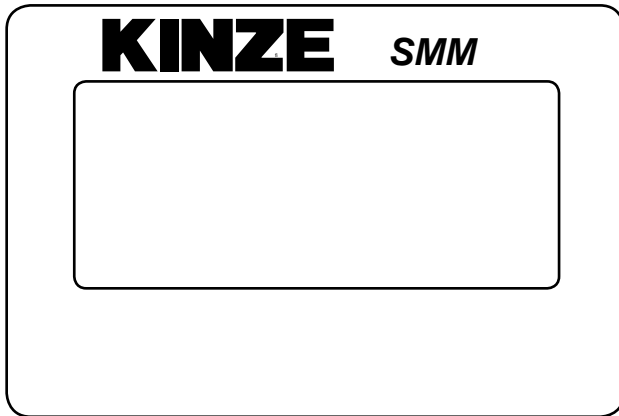

12060211

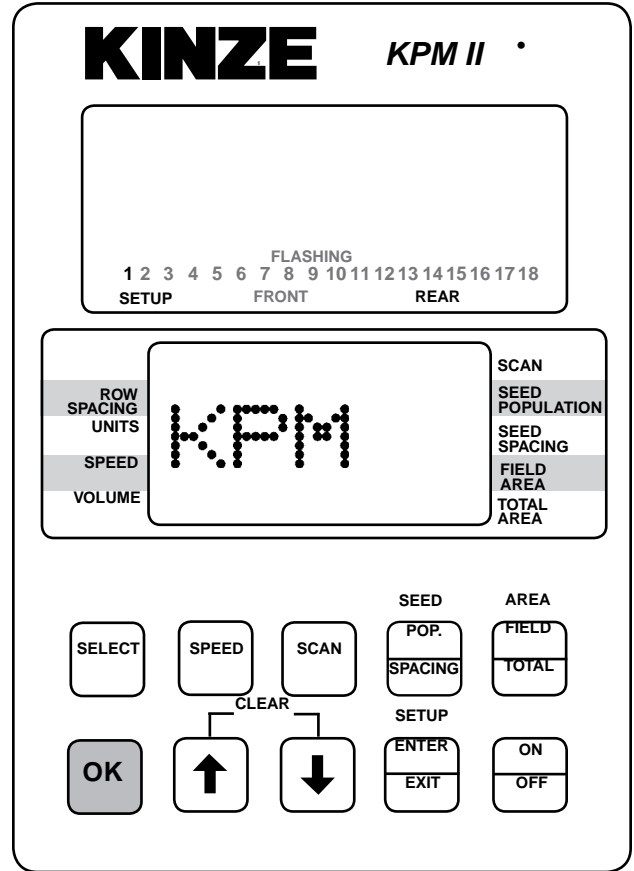
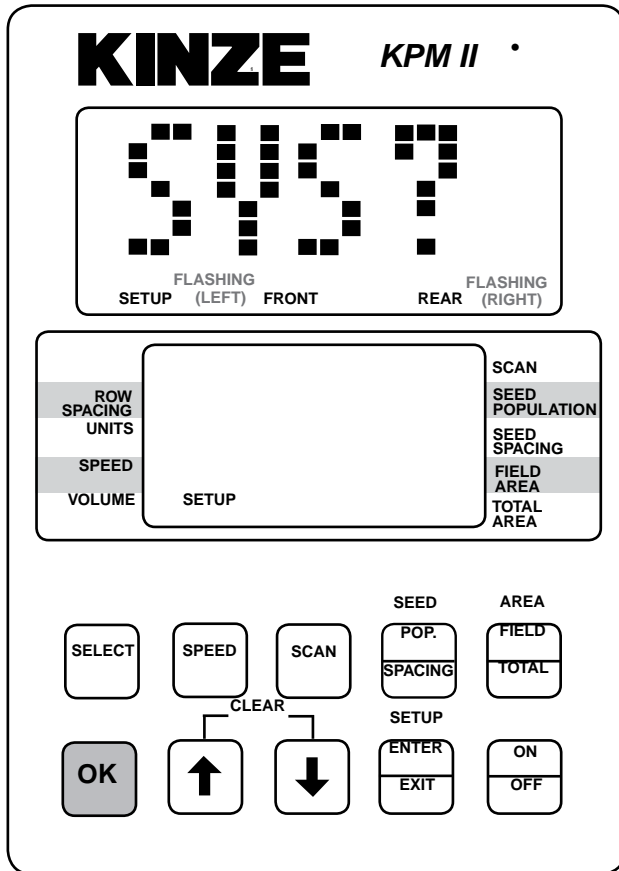

NOTE: SMM console may not be applicable to all models.

NOTE: SMM console may not be applicable to all models.

MACHINE OPERATION

KPM II STACK-MODE

STEP 6 If the monitor system includes shaft rotation sensors, these should be installed at this time. Plug in the L.H. shaft first, then the R.H. shaft. L.H. and R.H. is determined by facing in the direction the machine will travel when in use.

01189906

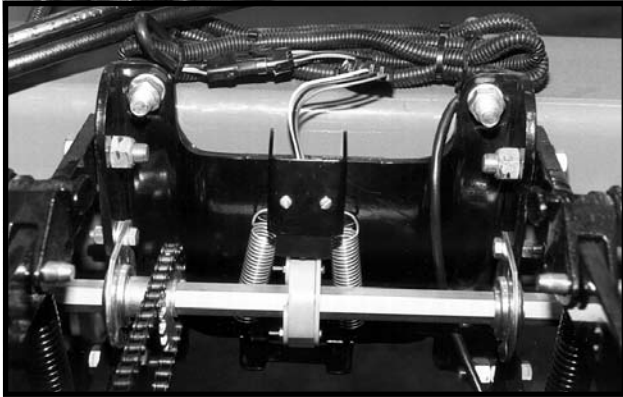

D12140713

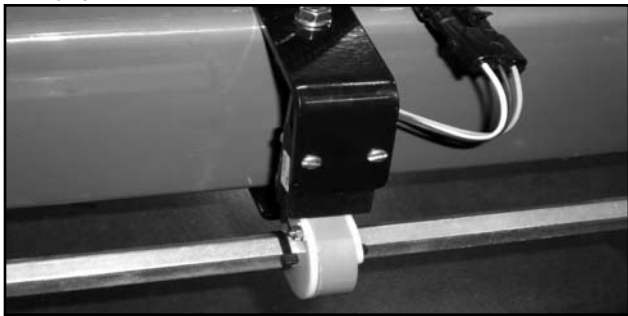

“LSHAFT” or “SHAFT 1” will display on the lower LCD when the first shaft rotation sensor is installed. “RSHAFT” or “SHAFT 2” will display when the second shaft rotation sensor is installed.

NOTE: Illustrated using rear/front configuration. The KPM II Stack-Mode console shows **LEFT** in the left/right configuration, **REAR** in the rear/front configuration and **FRONT LEFT/REAR LEFT** in the four sections configuration.

12060211

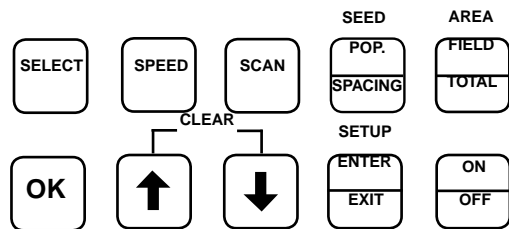
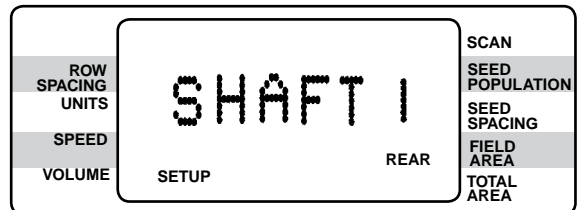
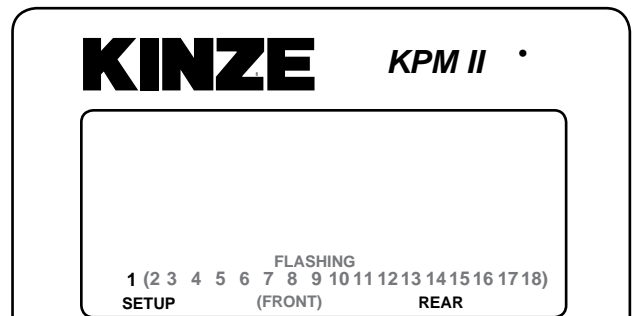

NOTE: SMM console may not be applicable to all models.

MACHINE OPERATION

KPM II STACK-MODE

STEP 6 (Continued)

12060211

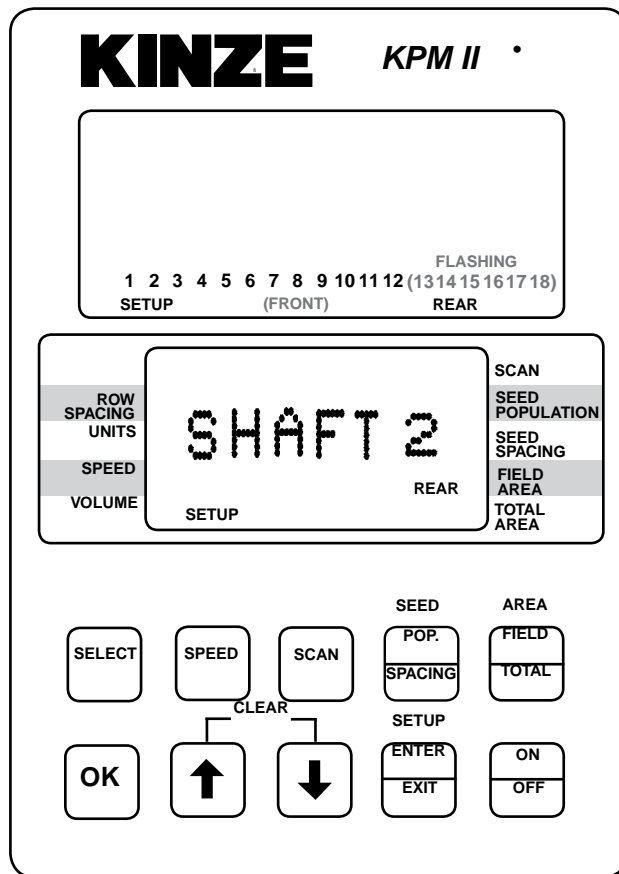

NOTE: SMM console may not be applicable to all models.

STEP 7 Determine which row you want as number one and plug the seed tube w/sensor into the harness.

Continue plugging in sensors along with shaft rotation sensors if so equipped. Row 1 first, row 2 second and so on up to 18 rows. When a sensor is plugged in, the corresponding row number on the upper LCD display will stay solid, the monitor will chirp twice and a red LED (Light Emitting Diode) on the seed tube sensor will turn on for approximately 30 seconds to show connection is made.

(A11948)

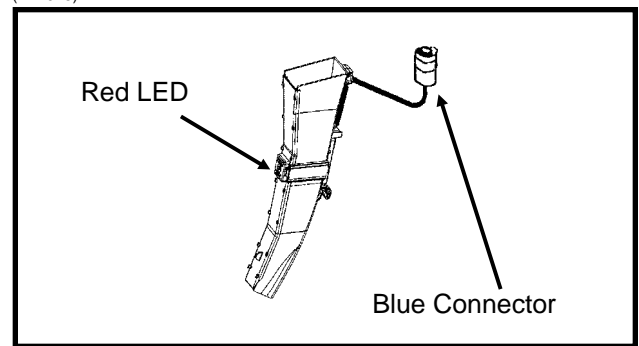

STEP 8 (Continued)

NOTE: Illustrated using rear/front configuration.
 The KPM II Stack-Mode console shows LEFT in the left/right configuration, REAR in the rear/front configuration and REAR LEFT/FRONT LEFT in the four sections configuration.

12060211

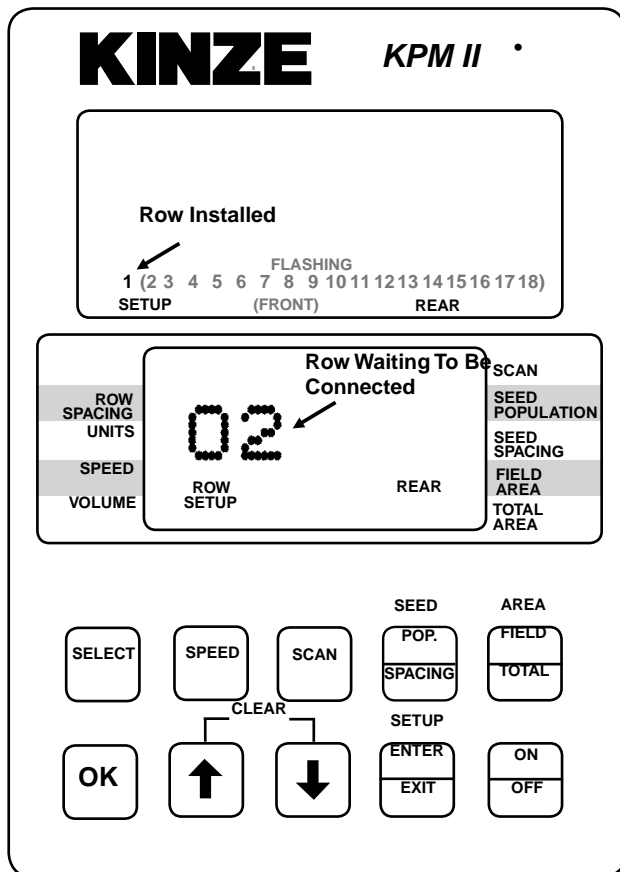

NOTE: SMM console may not be applicable to all models.

MACHINE OPERATION

KPM II STACK-MODE

STEP 8 When all the seed tubes for the current section (rear/front, left/right or four section) are installed, check to be sure the upper LCD on the KPM II Stack-Mode console displays solid numbers for the number of seed tubes connected. Press and hold the OK key to save the setup for the current section. The SAVE? icon will display followed by continuous short beeps indicating the monitor is preparing to save. The installer has 5 seconds to decide to save the current configuration. During this time, four short beeps will sound followed by a long beep and the SAVE? icon will turn off and the word "DONE" shows on the screen. The monitor will continue to the second section installation (If Applicable).

NOTE: Illustrated using rear/front configuration. The KPM II Stack-Mode console shows LEFT in the left/right configuration, REAR in the rear/front configuration and FRONT LEFT/REAR LEFT in the four sections configuration.

12060211

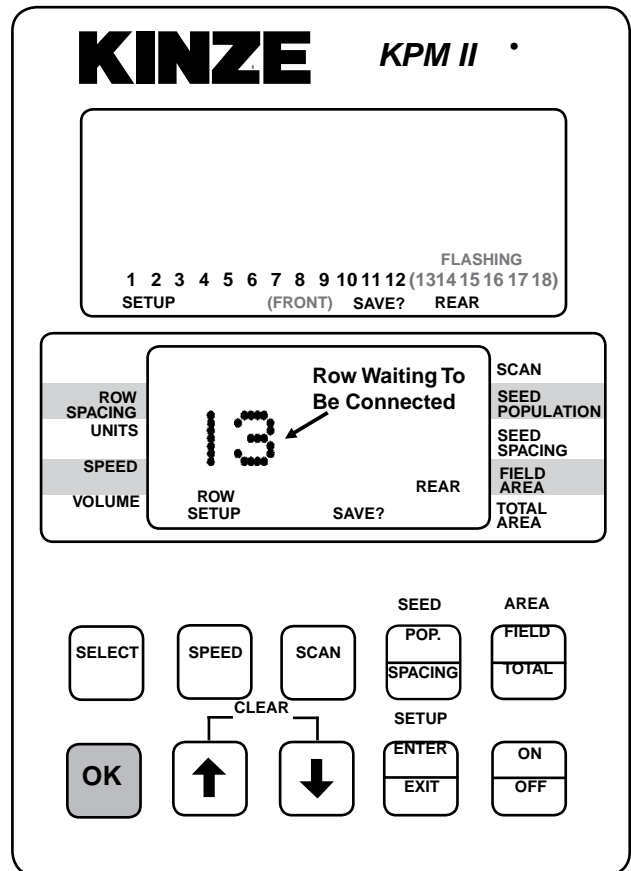

NOTE: SMM console may not be applicable to all models.

STEP 8 (Continued)

12060211

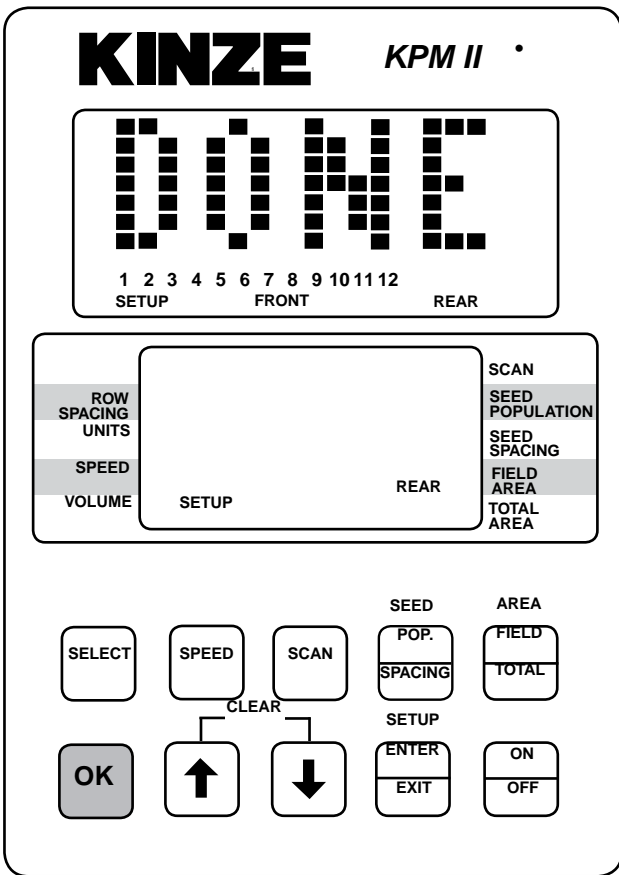

NOTE: SMM console may not be applicable to all models.

MACHINE OPERATION

KPM II STACK-MODE

STEP 9 Follow STEPS 6, 7 and 8 to install the second, third and fourth sections (If Applicable). If no seed tubes are installed on additional sections, press and hold the OK key. The word "DONE" will appear on upper display. The alarm will sound four short beeps followed by one long beep and the SAVE? icon turns off. The monitor has exited the setup mode. When you release the OK key the upper display will scroll "WAITING CALIBRATION". The lower display will show "GNDSPD" and the alarm will sound continually until the distance sensor is connected. See STEP 10.

NOTE: The SMM console LCD remains blank (except the backlighted screen) until the entire system is saved.

NOTE: Illustrated using rear/front configuration. The KPM II Stack-Mode console shows LEFT in the left/right configuration, REAR in the rear/front configuration and FRONT LEFT/REAR LEFT in the four sections configuration. The SMM console shows RIGHT in the left/right configuration, FRONT in the front/rear configuration and FRONT RIGHT/REAR RIGHT in four sections configuration.

12060212

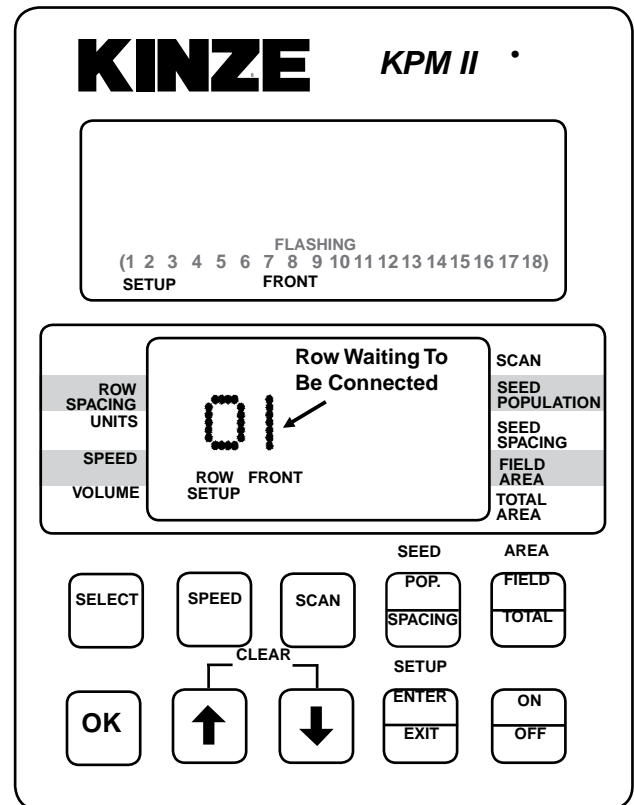

NOTE: SMM console may not be applicable to all models.

MACHINE OPERATION

KPM II STACK-MODE

STEP 9 (Continued)

12060213

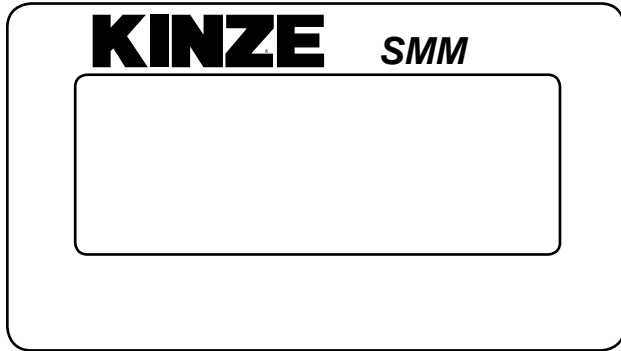

12060214

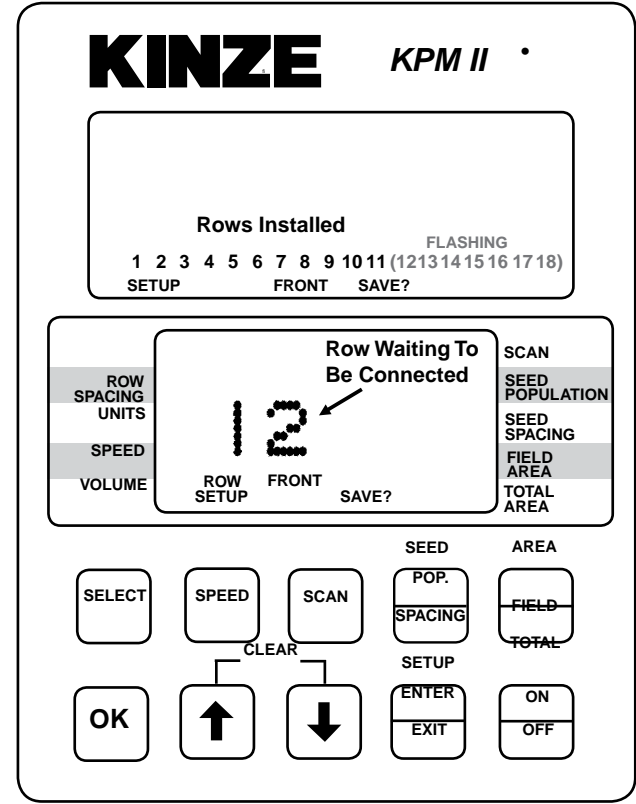
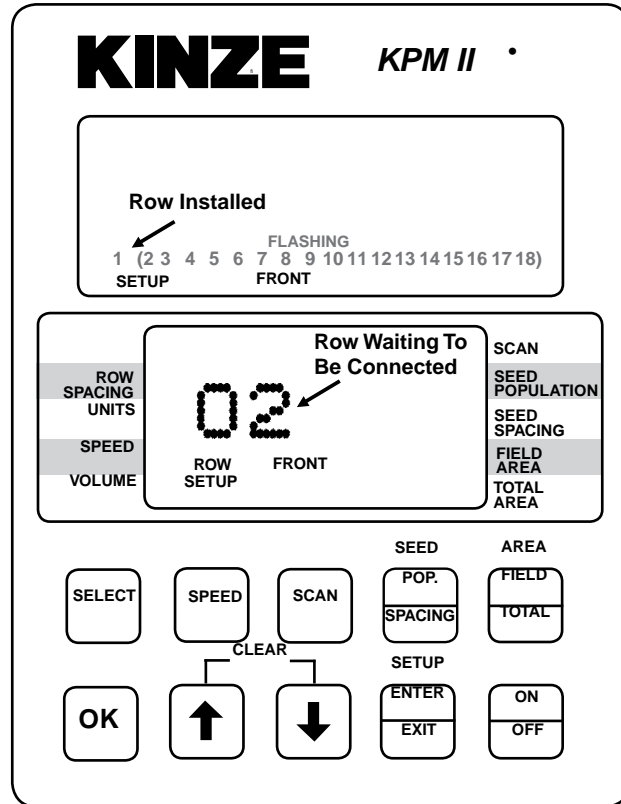
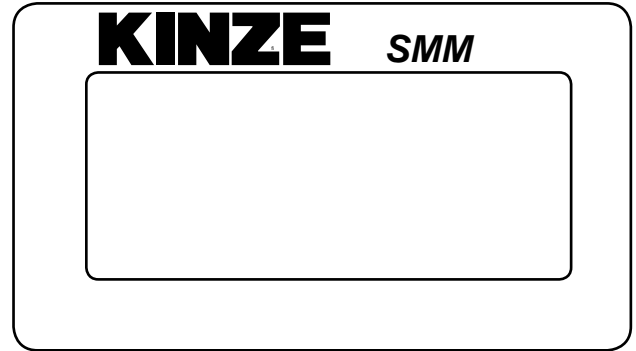

NOTE: SMM console may not be applicable to all models.

NOTE: SMM console may not be applicable to all models.

MACHINE OPERATION

KPM II STACK-MODE

STEP 9 (Continued)

12060215

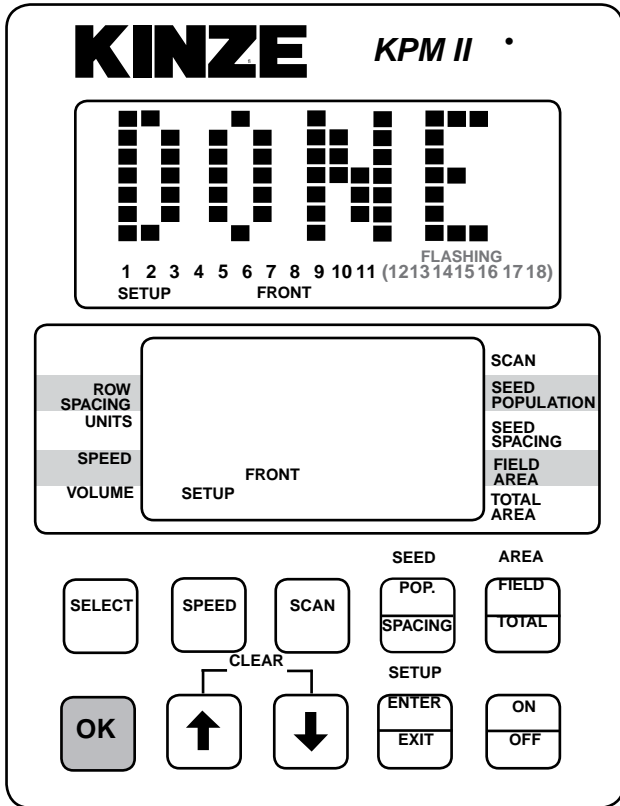
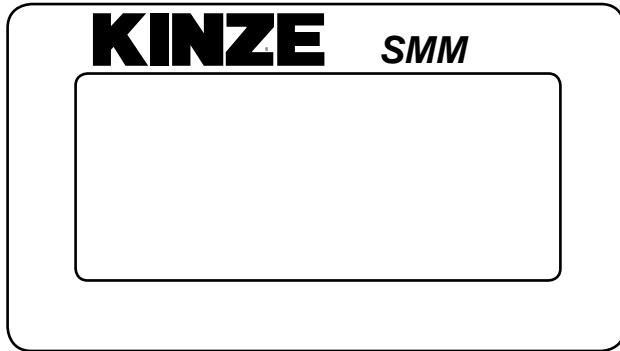

NOTE: SMM console may not be applicable to all models.

STEP 10 With the lower display showing “GNDSPD”, connect the distance sensor. The monitor will display “PICKUP” if a magnetic distance sensor is connected or “RADAR” if a radar distance sensor is installed. Only one distance sensor can be connected at a time.

NOTE: To connect the radar distance sensor, install the 10" monitor/radar adapter between the console and radar distance sensor to adapt the monitor system to various tractor radar systems. **DO NOT CONNECT 10" MONITOR/RADAR ADAPTER PRIOR TO THIS STEP.**

MACHINE OPERATION

KPM II STACK-MODE

STEP 10 (Continued)

NOTE: Illustrated using rear/front configuration.
 The KPM II Stack-Mode console shows LEFT in the left/right configuration, REAR in the rear/front configuration and FRONT LEFT/REAR LEFT in the four sections configuration. The SMM console shows RIGHT in the left/right configuration, FRONT in the rear/front configuration and FRONT RIGHT/REAR RIGHT in four sections configuration.

12060216

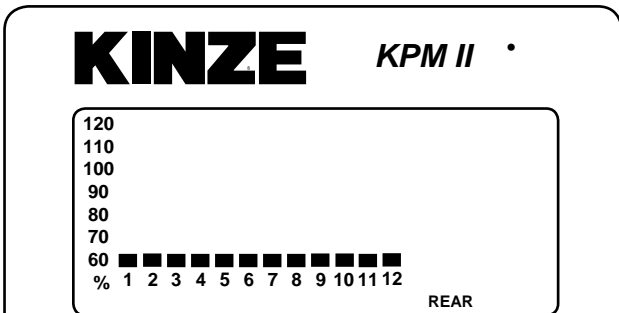
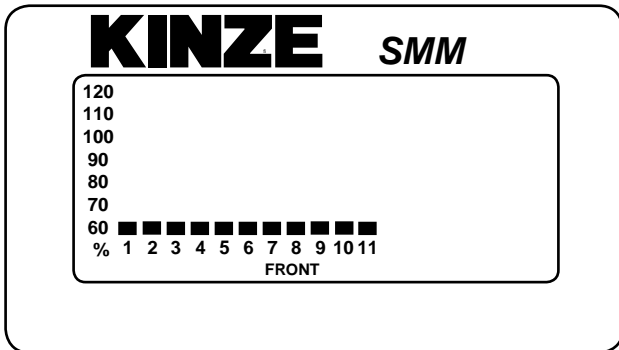

KINZE KPM II

120
110
100
90
80
70
60

% 1 2 3 4 5 6 7 8 9 10 11 12

REAR

ROW SPACING UNITS	GNDSPD	SCAN
SPEED		SEED POPULATION
VOLUME		SEED SPACING
		FIELD AREA
		TOTAL AREA

SEED POP. FIELD
SPACING TOTAL

CLEAR SETUP
OK ↑ ↓ ENTER EXIT ON OFF

NOTE: SMM console may not be applicable to all models.

NOTE: To reprogram the system to monitor more or less rows (up to the maximum of 18 per section, 72 total in four section configuration), all sensors must be unplugged, followed by the complete setup procedure.

NOTE: Individual seed tubes may be unplugged for special situations. An alarm will sound which can be silenced by touching the OK key. The monitor will recognize the seed tube(s) when reconnected.

12060217

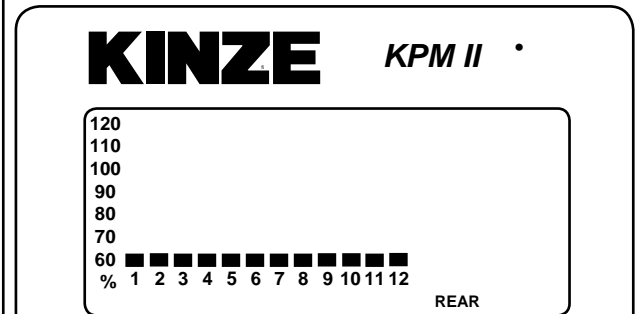
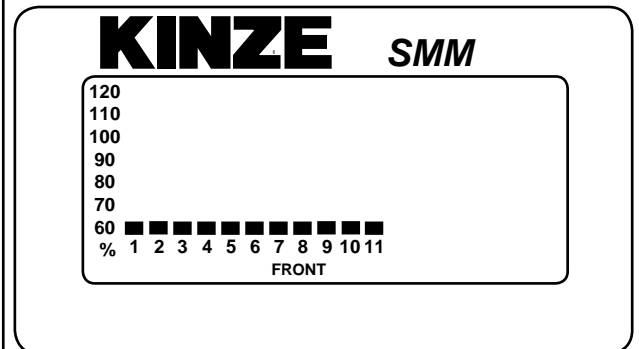

KINZE KPM II

120
110
100
90
80
70
60

% 1 2 3 4 5 6 7 8 9 10 11 12

REAR

ROW SPACING UNITS	MPH	SCAN
SPEED		SEED POPULATION
VOLUME		SEED SPACING
		FIELD AREA
		TOTAL AREA

SEED POP. FIELD
SPACING TOTAL

CLEAR SETUP
OK ↑ ↓ ENTER EXIT ON OFF

NOTE: SMM console may not be applicable to all models.

MACHINE OPERATION

KPM II STACK-MODE

ROW-BY-ROW ALARM LEVEL SETTING
 (Requires Version V2.05 Or Higher Software -
 KPM II Stack-Mode Monitors Only)

This feature allows the audio alarm to be disabled on selected rows in applications such as planting seed corn.

NOTE: The system should be programmed to monitor all planter rows prior to performing these steps.

NOTE: Illustrated using rear/front configuration. The KPM II Stack-Mode console shows LEFT in the left/right configuration, REAR in the rear/front configuration and FRONT LEFT/REAR LEFT in the four sections configuration. The SMM console shows RIGHT in the left/right configuration, FRONT in the rear/front configuration and FRONT RIGHT/REAR RIGHT in four sections configuration.

STEP 1 Enter the programming mode by pressing and holding the SETUP key. The monitor will emit several short beeps, followed by a long beep. On the lower LCD, the SETUP icon will turn on and the arrow head icon will flash, indicating the user can select an item to program.

NOTE: The monitor must be in a programmable function (row spacing, unit, speed, volume or area) to enter setup. The monitor will not enter setup in seed population or seed spacing.

STEP 2 Press the UP or DOWN arrow keys to move the flashing arrow to SEED POPULATION. As the arrow icon moves, the lower LCD will display the current setting of each item selected.

12060218

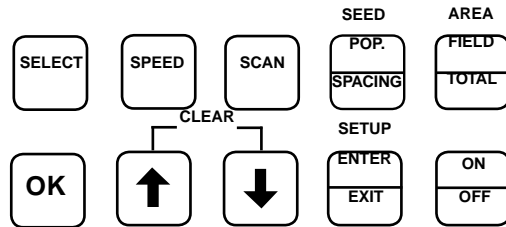
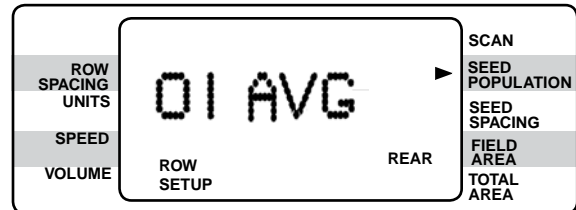
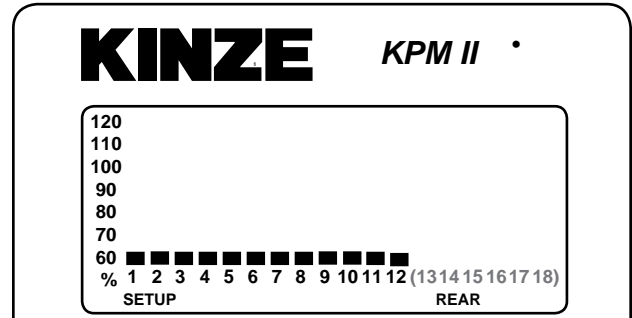
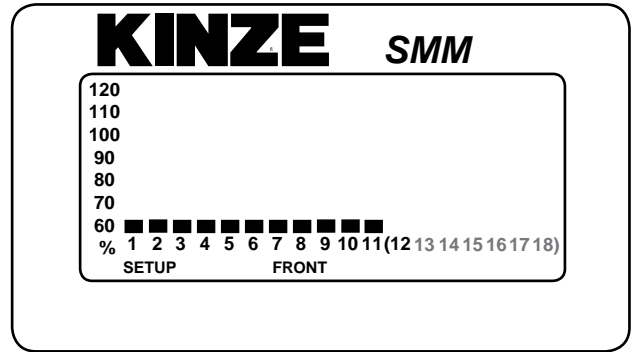

NOTE: SMM console may not be applicable to all models.

STEP 3 Press the OK key. Row number starts flashing.

STEP 4 Arrow UP or DOWN to desired row.

STEP 5 Press SELECT key. "AVG" starts flashing.

STEP 6 Arrow UP or DOWN to choose one of the following options.

HIGH - For Early Alarm (70%)

AVG - For Standard Alarm Setting (55%)

LOW - For Failed Alarm Only (25%)

OFF - To Disable Row Alarm

STEP 7 Press and hold the OK key to save alarm setting. There will be four short beeps, one long beep and the word "DONE" will appear when the save is completed.

STEP 8 Repeat STEPS 3 through 7 for each row on which you wish to adjust the alarm setting.

STEP 9 When finished, press the SETUP key to exit setup mode.

NOTE: The programming mode may be exited at any time by pressing the SETUP key. Pressing this key will return the monitor to its normal operation. All items changed and saved will come into effect immediately. Any items changed, but not saved will revert to the original programmed value.

NOTE: Repeat STEPS 3 through 7 to change seed monitor back to the original settings when special row-by-row alarm level settings are no longer required.

NOTE:

See "Programming - Row Spacing" for programming applicable row spacing.

See "KPM I/KPM II Stack-Mode Electronic Seed Monitors Troubleshooting" in the Maintenance Section.

KPM III ELECTRONIC SEED MONITOR

D10190501



The KPM III electronic seed monitor system consists of (a) a KPM III console, which is mounted on the tractor; (b) seed tubes with sensors, one of which is installed in each planter row unit; (c) a magnetic distance sensor, which is installed on the planter, or a radar distance sensor, which is installed on the tractor; (d) shaft rotation sensors (if applicable), which are installed on the planter drill shafts; and (e) planter harnesses (junction Y-harness and/or extension harness where applicable), to which the individual seed tube sensors connect. The primary harness, which connects the monitor console to the planter harness, is hard-wired into the safety/warning light harness or control console harness included as standard equipment with the planter.

The software design of the KPM III console allows simultaneous viewing of seed flow bargraphs for standard and/or Interplant® System rows (up to 36 rows).

The monitor system is powered by the tractor battery (requires 12 volts DC). The console receives information from each of the sensors and translates this information.

The KPM III console uses a single backlit Liquid Crystal Display (LCD) to show, the number of monitored rows, the relative seed rate for each row (using bargraph displays) and displays various alarm and warning messages when an alarm condition exists. A continuous audible alarm will sound upon system malfunction or underflow conditions for any monitored row. Alarms must be acknowledged by the user. Various warnings may sound the alarm or flash one or more messages. The LCD also shows alphanumeric data such as row spacing, units (Metric or English), speed (MPH or KM/H), volume, seed population, seed spacing, field area and total area.

The monitor system will power down if no activity is detected within one hour. No activity means there has been no new seed flow and no operator push key input.

Monitor Key Functions.....	6-56
Configuring Planter Monitor	6-57
Programming/Connecting Seed Tubes, Shaft Rotation Sensors And/OR Radar/Magnetic Distance Sensors.....	6-59
Changing Volume, Contrast And Backlighting	6-61
Programming Interplant® Condition, Row Spacing And Units (Metric Or English)	6-62
Programming Row Unit Alarms Levels	6-63
Speed Sensor Calibration/Programming	6-64
Reprogramming Speed Sensor.....	6-65
Adding Interplant® Rows (If Rear Rows Have Previously Been Programmed).....	6-69
Adding Even-Row Package (If Front Rows Have Previously Been Programmed).....	6-71
Enabling/Disabling Interplant® Rows.....	6-73
Warnings And Alarms	6-76
Field Operation	6-78
Area Management.....	6-79
Area Counters.....	6-81
Clearing Field Area.....	6-82
Acre Count Mode.....	6-82
Replacing Faulty Sensor(s)	6-84

MONITOR KEY FUNCTIONS

Push keys allow the user to select or change the operating mode, the active displays or the current configuration. Depending on the operating mode or the current display selected, some keys may not be active. Each key press, if valid, is acknowledged by a short beep and an action is taken. If the key press has no action associated, the key press is considered invalid, and the user will not receive feedback.

D10190501

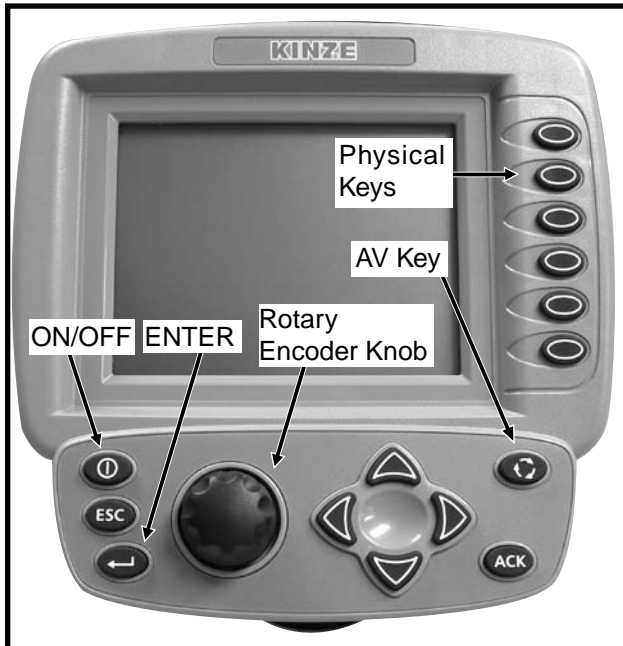

PHYSICAL KEYS

- Located on R.H. side of console and referred to as F1, F2, F3, F4, F5 and F6
- Keys are referenced in descending order with F1 at the top and F6 at the bottom.



ON/OFF KEY

- Powers the unit on and off.



ESC KEY

- Used as the CANCEL (escape) key.



ENTER KEY

- Confirms or accepts the highlighted selection.



ROTARY ENCODER KNOB

- Turn knob clockwise to increase or counterclockwise to decrease value of item.
- Turn knob clockwise to scroll up or counterclockwise to scroll down.
- Press knob to enter selection.

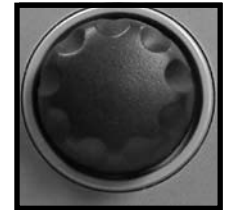

AV (AUDIO/VIDEO) KEY

- Set alarm volume.
- Adjust the contrast.
- Adjust backlighting of the LCD display.



ACK (ACKNOWLEDGE) KEY

- Used to silence (acknowledge) the warning alarm when various error conditions occur.

NOTE: Alarms can be viewed by pressing the STATUS key.



ARROW KEYS

- UP arrow key is used to increase the value of an item by one or to scroll up.
- DOWN arrow key is used to decrease the value of an item by one or to scroll down.
- LEFT arrow key multiplies the numeric value of the item by 10.
- RIGHT arrow key divides the numeric value of the item by 10.



NOTE: Within the LCD, the black box around the smaller box as shown below indicates which field is selected/highlighted. Turning the rotary encoder knob or pressing the UP or DOWN arrow keys moves the black box. When the black box is positioned on a programmable item, such as Shaft Sensors, Speed Sensor, Front Row Units or Rear Row Units, pressing the knob or ENTER key will highlight the programmable item. A programmable item may only be changed when it is highlighted.

D02140616

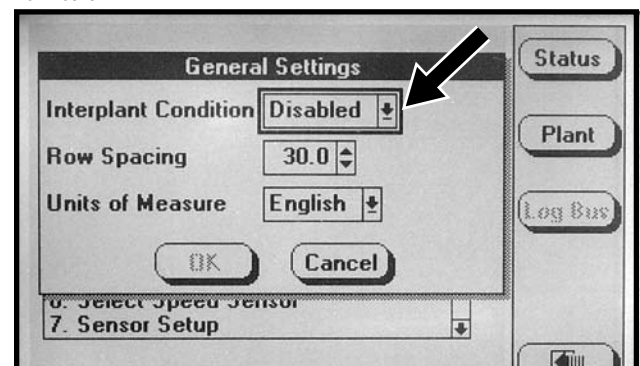

CONFIGURING PLANTER MONITOR

When the KPM III is powered on for the first time it will go directly into the “Planter Configuration” screen (STEP 4).

STEP 1 Press the F6 key until “Mode Selection” screen appears.

D02140614

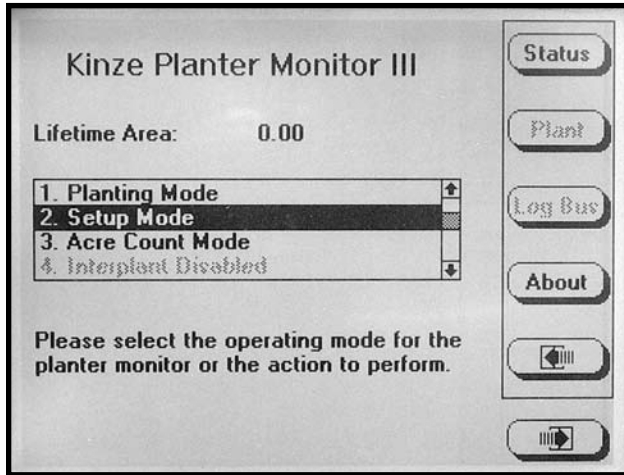

STEP 2 Select “Setup Mode” by turning the rotary encoder knob or using the UP or DOWN arrow keys. Press the knob or ENTER key to display highlighted item.

STEP 3 Select “Configure Planter Monitor” by turning the knob or using the UP and DOWN arrow keys. Press the knob or the ENTER key to display the highlighted item.

D02140624

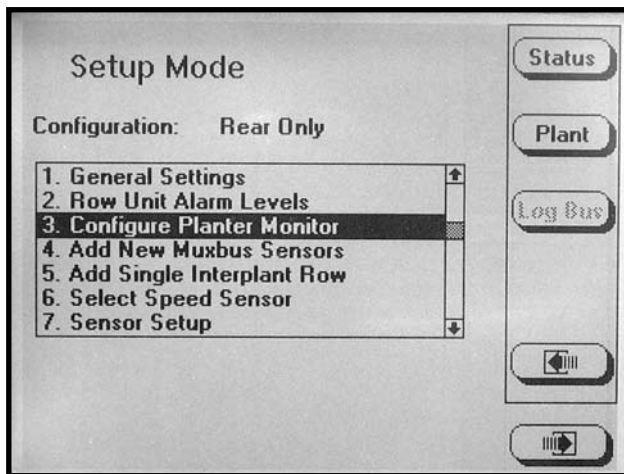

NOTE: The planter monitor cannot be reconfigured while planting.

NOTE: If the monitor has already been configured the message shown below will appear.

D02140634

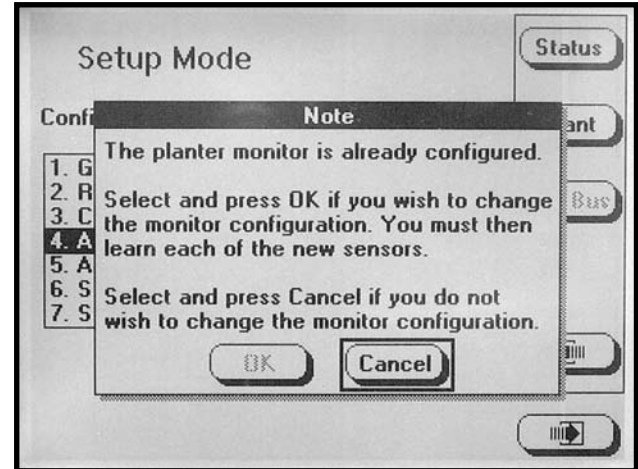

STEP 4 Press the knob or ENTER key, to highlight the “Shaft Sensors” field. Enter the number of “Shaft Sensors” by turning the knob or using the UP or DOWN arrow keys. When the correct value is displayed press the knob or ENTER key. The black box will advance to “Speed Sensor” field.

D05310601

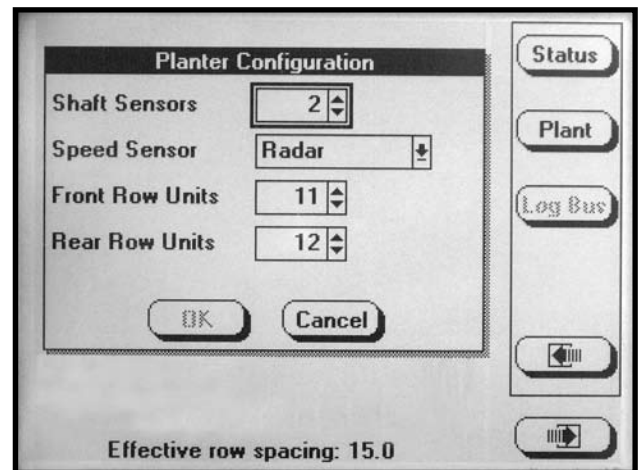

NOTE: The numeric value may be changed only if the item is highlighted. Turning the rotary encoder knob increases or decreases the value of the item. The UP arrow key may be used to increase the value of the item by one and the DOWN arrow key may be used to decrease the value of the field by one.

STEP 5 Press the knob or ENTER key and a drop down menu will appear; select either “Radar” or “Coil Pick-Up” (MDS) by turning the knob or using the UP or DOWN arrow keys. When the desired selection is highlighted press the knob or ENTER key. The black box will advance to “Front Row Units” field.

D05310604

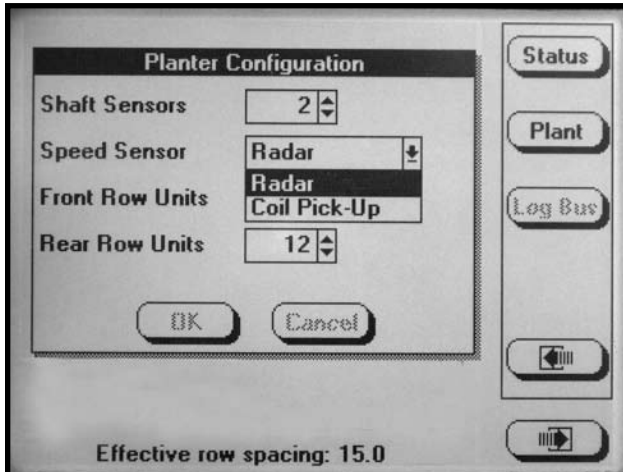

STEP 7 Press the knob or ENTER key to highlight the “Rear Row Units” field. Turn the knob or use the UP or DOWN arrow keys to obtain correct number of pull row units. Press the knob or ENTER key when desired quantity is displayed. The black box will advance to the OK key.

D05310606

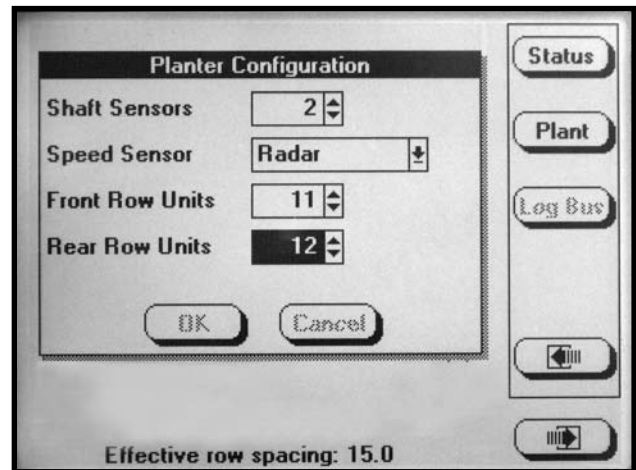

STEP 6 If there are front rows on the planter, press the knob or ENTER key to highlight the “Front Row Units” field. Turn the knob or use the UP or DOWN arrow keys to obtain correct number of push row units. Press the knob or ENTER key when desired quantity is displayed. The black box will advance to “Rear Row Units” field. If no front rows need to be entered simply turn the knob or press the DOWN arrow key to advance to “Rear Row Units”.

STEP 8 Press the knob or the ENTER key to save the information.

D05310607

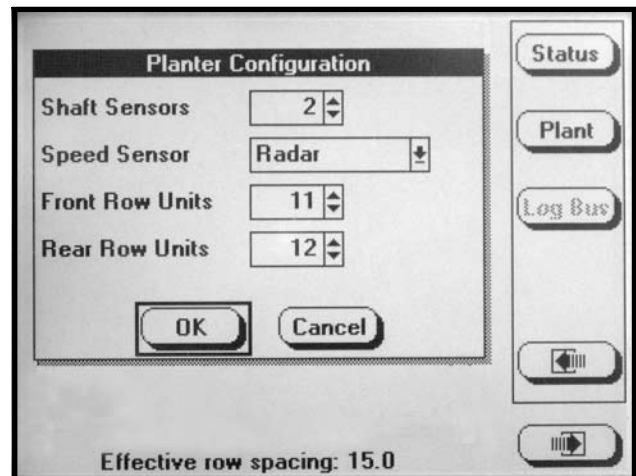

D05310605

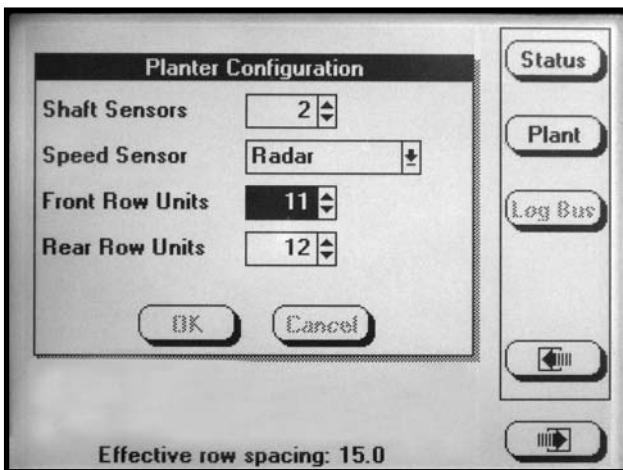

NOTE: To prevent the configuration from being saved press ESC or select the CANCEL button, then press the rotary encoder knob or ENTER key.

STEP 9 The monitor screen shown below will appear.

If the new planter configuration is to be saved turn the knob or press the UP or DOWN arrow keys to select the OK button then press the knob or ENTER key to save the planter configuration. If the monitor configuration is not to be changed select the CANCEL key, press the knob or ENTER key to CANCEL or press the ESC key.

If OK is selected the monitor will advance to "Sensor Setup"(STEP 4 in PROGRAMMING/CONNECTING SEED TUBES, SHAFT ROTATION SENSORS AND/OR RADAR/MAGNETIC DISTANCE SENSORS section).

NOTE: STEP 9 does not apply if configuring the monitor for the first time.

D02140634

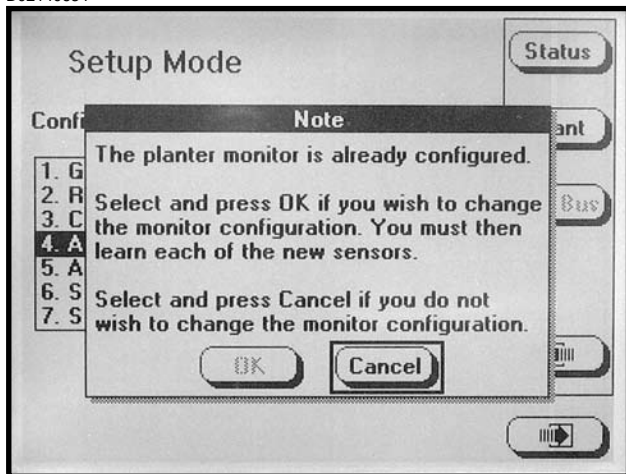

PROGRAMMING/CONNECTING SEED TUBES, SHAFT ROTATION SENSORS AND/OR RADAR/MAGNETIC DISTANCE SENSORS

STEP 1 To enter "Mode Selection", press F6 key until the "Mode Selection" screen appears.

STEP 2 Select "Setup Mode" by turning the rotary encoder knob or press the UP or DOWN arrow keys. Press the knob or ENTER key to display the highlighted item.

STEP 3 Select "Sensor Setup" by turning the knob or using the UP or DOWN arrow keys. Press the knob or ENTER key to display the highlighted item.

D02140641

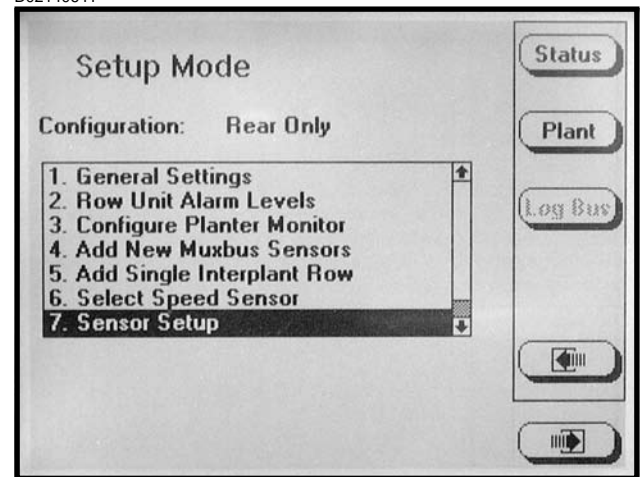

STEP 4 Attach the planter harness to the KPM III. Do NOT connect any of the sensors to the planter harness. With [Auto Detect] selected press the INSTALL key.

D02210601a

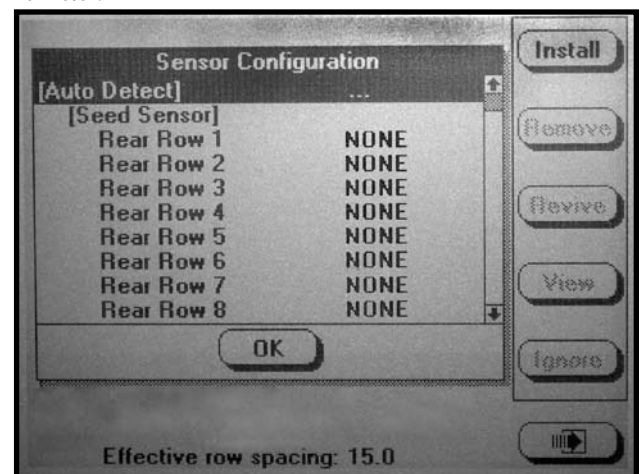

STEP 5 Plug in the first seed sensor (row 1), working from left to right (rear row units and front next if applicable). When a sensor is connected to the planter harness wait for the monitor to acknowledge with two beeps.

Continue connecting seed sensors along with shaft rotation sensors or speed sensors. Progress will reflect on the LCD screen. The example below indicates that the last seed sensor found was Front Row 7 and the monitor is looking for the next sensor.

When all sensors are installed press the F1 key to end the installation.

D02170617

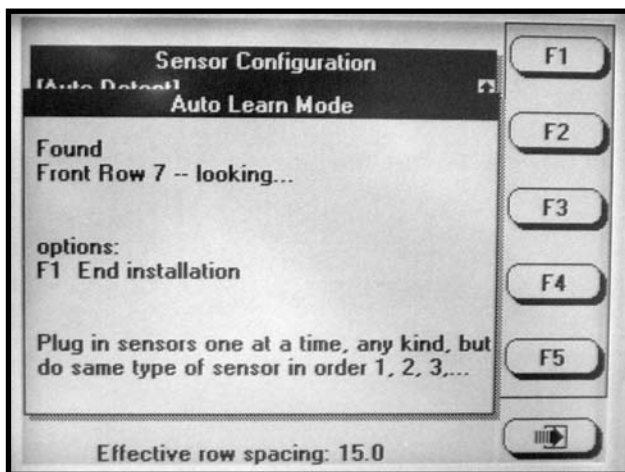

NOTE: After each sensor has been installed “OK” will appear after the sensor name.

D02210601b

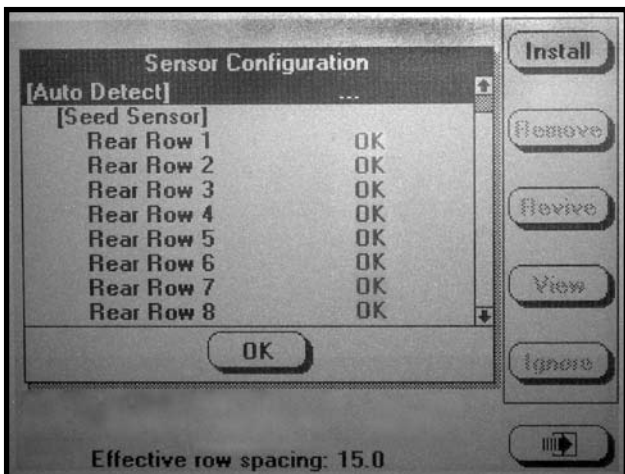

STEP 6 If “OK” appears behind ALL sensors, press the knob or the ENTER key to save the configuration. The “Setup Mode” menu will then appear.

NOTE: If “NONE” appears after a sensor, the sensor was not recognized. All sensors must be disconnected from the planter harness and reconnected as described in STEP 5.

NOTE: If “OK slow” appears after a sensor, the sensor is able to communicate but at a slower speed. For the system to run at top speed of 9600 baud the slow sensor must be replaced.

D05310609

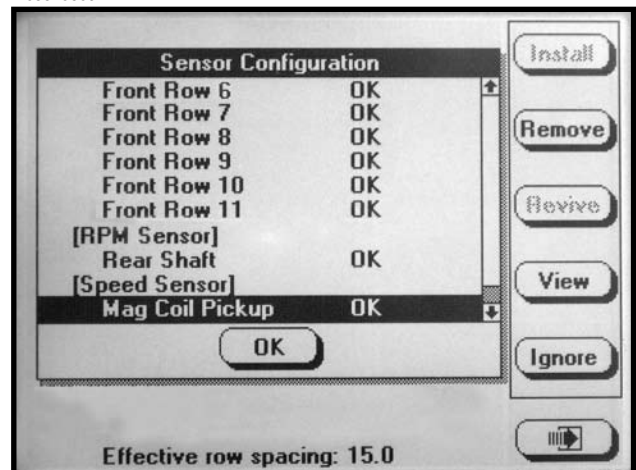

STEP 7 To return to “Planting Mode” select the PLANT key or press the F6 key until “Planting Mode” screen appears.

CHANGING VOLUME, CONTRAST AND BACKLIGHTING

The alarm volume and LCD screen contrast and backlighting may be adjusted at anytime, regardless of what is displayed on the screen.

STEP 1 Press the AV key. The speaker adjustment dialog box will appear in the lower L.H. corner of the display.

D05310610

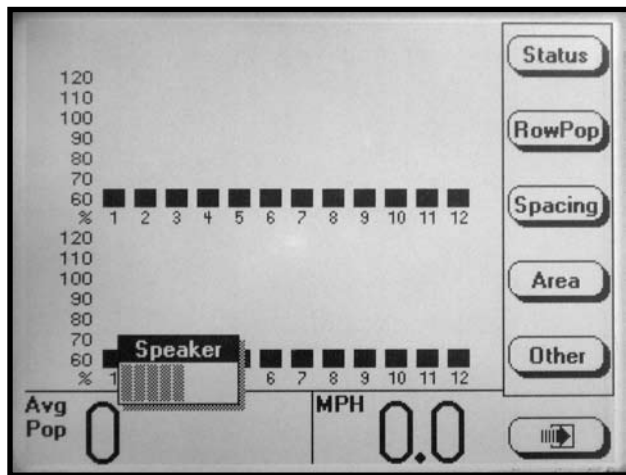

STEP 2 Use the LEFT and RIGHT arrows or turn the rotary encoder knob to adjust the volume. The volume of the sound emitted from the speaker changes as the adjustment is being made.

STEP 3 To adjust contrast or backlight, go to STEP 4. If finished press ENTER to save and exit.

STEP 4 Press the AV button a second time. The contrast adjustment dialog box will appear in the lower portion of the display.

D05310611

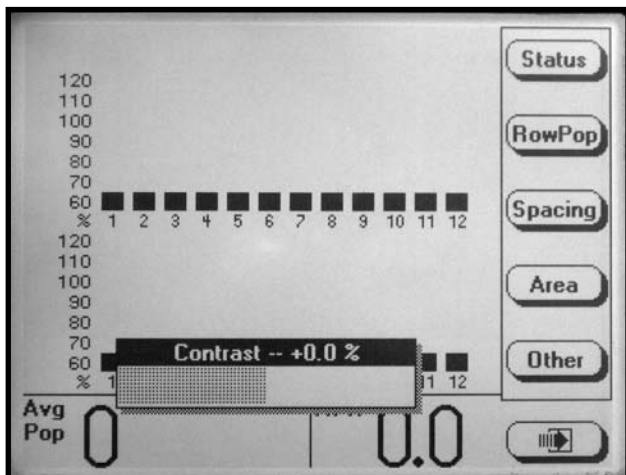

STEP 5 Use the LEFT and RIGHT arrows or turn the knob to adjust contrast. The effect of the adjustment will be visible on the display.

STEP 6 To adjust backlighting go to STEP 7. If finished press ENTER to save and exit.

STEP 7 Press the AV button a third time. The backlight adjustment dialog box will appear in the lower L.H. corner of the display.

D05310612

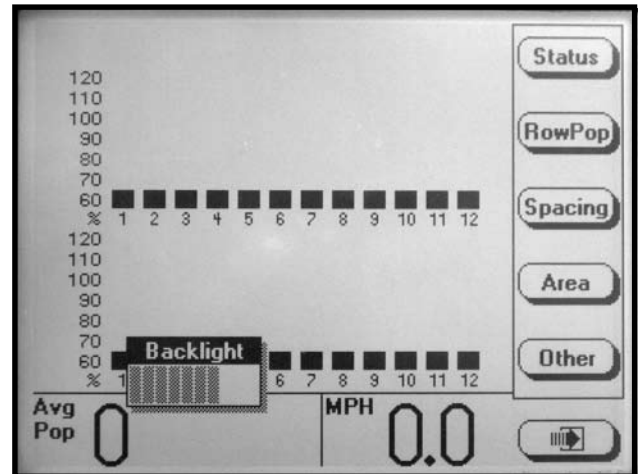

STEP 8 Use the LEFT and RIGHT arrows or turn the knob to adjust backlighting. The effect of the adjustment will be visible on the display.

STEP 9 Press the knob, ENTER or press the AV button a fourth time to save the volume, contrast and backlight settings. The backlight adjustment dialog box will disappear.

PROGRAMMING INTERPLANT® CONDITION,
ROW SPACING AND UNITS (Metric Or English)

STEP 1 To enter “Mode Selection” screen press the F6 key until “Mode Selection” screen appears.

D02140614

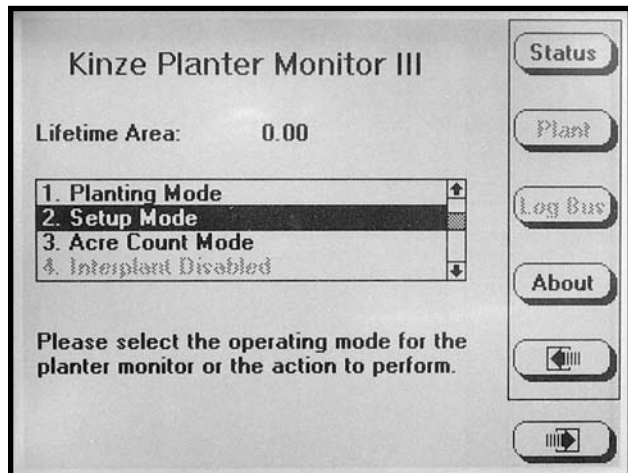

STEP 2 Select “Setup Mode” by turning the rotary encoder knob or using the UP or DOWN arrow keys. Press the knob or ENTER key to display the highlighted item.

STEP 3 Select “General Settings” by turning the knob or using the UP or DOWN arrow keys. Press the knob or the ENTER key to display the highlighted item.

D02140615

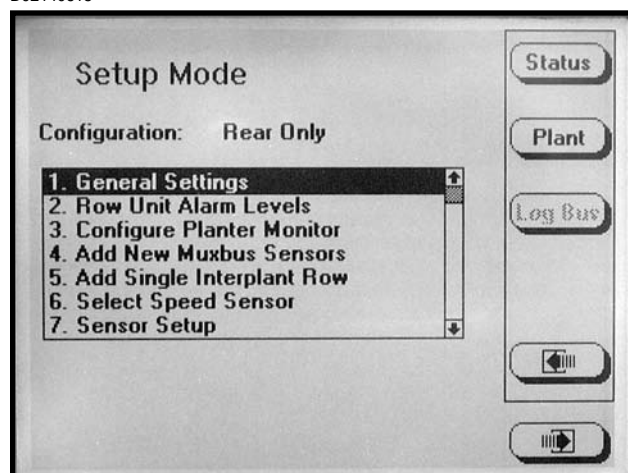

STEP 4 Press the knob or ENTER key and a drop down menu will appear. Select either “Enabled” (push row units are being used for planting) or “Disabled” (push row units are not being used for planting and no seed rate alarms will be generated for the front rows; no bargraphs are to be displayed for the front rows and the front rows do not contribute to the average population and spacing or acre counts). Use the knob or UP or DOWN arrow keys to make selection. Press the knob or ENTER key to select highlighted item. The black box will advance to “Row Spacing” field.

D02140616

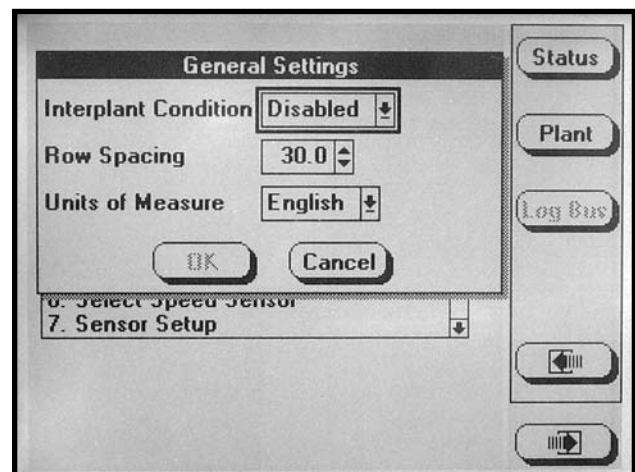

NOTE: When English is selected inches are displayed, if Metric is selected centimeters are displayed.

STEP 5 Press the knob or ENTER key to enter the correct value for “Row Spacing”. Turn the knob to increase or decrease the number. The UP arrow key is used to increase the value of the item by one and the DOWN arrow key is used to decrease the value of the field by one. The LEFT arrow key multiplies the value of the item by 10 and the RIGHT arrow key divides the value of the item by 10. When the correct number has been entered press the knob or ENTER key. The black box will advance to “Units of Measure” field.

NOTE: The narrowest row spacing the planter is equipped to plant should be entered for “Row Spacing”. Example: 12 Row 30" with Interplant, row spacing would be set to 15".

STEP 6 Select “Units Of Measure” field by pressing the knob or ENTER key and a drop down menu will appear. Select either “English” or “Metric” by turning the knob or using the UP or DOWN arrow keys. Press the knob or the ENTER key. The black box will advance to OK.

STEP 7 Press the knob or ENTER key, when correct values are entered.

STEP 8 To return to “Planting Mode” press the PLANT key.

PROGRAMMING ROW UNIT ALARM LEVELS

The Row Unit Alarm Levels allow the thresholds for the seed rate alarms to be set. The default is 50% or Average. If the average population drops below 50% for a given row a seed rate alarm will be generated for that row unit. The alarm threshold can be set to 70%, 50%, 10% or disabled for any row.

NOTE: When the alarm threshold is disabled for any row no seed rate alarm will be generated.

D02140623

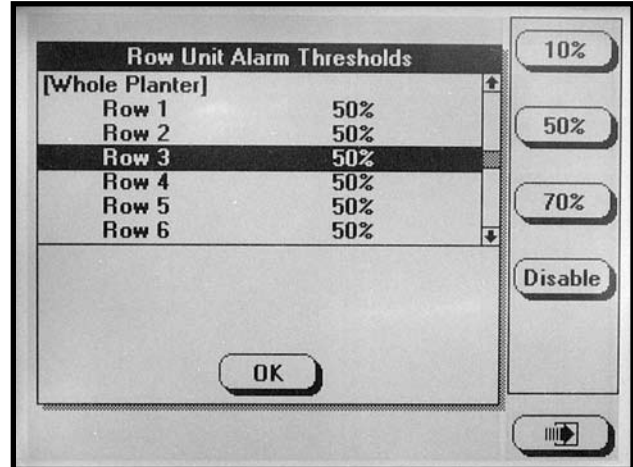

The alarm thresholds can be set for the whole planter, any planter section or individual rows.

NOTE: A section is determined by a set of rows driven by one or more shafts, designated to a single shaft sensor.

STEP 1 To enter “Mode Selection”, press F6 key until the “Mode Selection” screen appears.

STEP 2 Select “Setup Mode” by turning the rotary encoder knob or using the UP or DOWN arrow keys. Press the knob or ENTER key to display the highlighted item.

STEP 3 Select “Row Unit Alarm Levels” by turning the knob or using the UP or DOWN arrow keys. Press the knob or ENTER key to display the highlighted item.

STEP 4 To set alarm thresholds for whole planter, select “Whole Planter”. Press the key next to the desired threshold. When the desired threshold has been specified for all row units, press the knob or ENTER key.

To set alarm thresholds for all the rows in one section, select rear section or front section. Press the key next to the desired threshold. When the desired threshold has been specified for all row units, press the knob or ENTER key.

To set alarm thresholds for individual rows, select the desired row. Press the key next to the desired threshold. When the desired threshold has been specified for all row units, press the knob or ENTER key.

STEP 5 To return to “Planting Mode” press the PLANT key.

SPEED SENSOR CALIBRATION/PROGRAMMING

STEP 1 To enter the “Speed Sensor Calibration” mode, press F6 until the “Mode Selection” screen appears. (If Applicable) Select “Setup Mode” and press the rotary encoder knob or ENTER key. Press F6 to advance to the “Speed Sensor Calibration” screen.

The Distance Pulse Count is used to record how many pulses are generated per mile/kilometer from the ground speed sensor. The monitor will display the current pulses per mile/kilometer using a 6 digit, no decimal place format.

D02140643

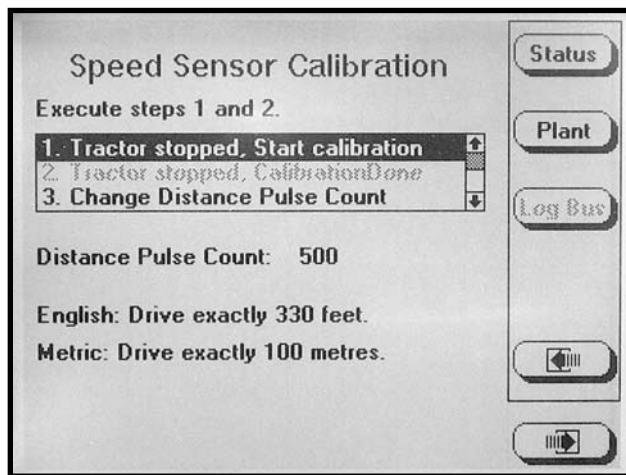

NOTE: A field calibration must be performed to establish the Distance Pulse Count number. Several factors can affect this value, such as wheel slip on the magnetic distance sensor. IT IS NOT UNCOMMON FOR THE SPEED ON THE MONITOR TO VARY SLIGHTLY FROM THE TRACTOR SPEEDOMETER. *Adjusting the Distance Pulse Count in the monitor to make the speed agree with the tractor can cause serious errors in acre/hectare and population/spacing readings. Do field checks to verify populations and seed spacing.*

- In field conditions, measure 330 feet or 100 meters, depending on the unit of measurement selected. Place a marker at the start point and end point.
- Pull the tractor up to the starting point.
- Select “Tractor stopped. Start calibration”.
- Press the rotary encoder knob or ENTER key to change the Distance Pulse Count on the display to 0.

NOTE: If the Distance Pulse Count number starts to count pulses with the tractor not moving, check radar distance sensor for vibration or other interference.

- Drive the tractor for 330 feet or 100 meters.
- The monitor will count the number of pulses and display them.
- Stop the tractor at the end point.
- Select “Tractor stopped. Calibration Done”.
- Press the knob or ENTER key.

NOTE: Repeat the above steps multiple times. Record and average the values. Use this average for the Distance Pulse Count number constant.

STEP 2 Select “Change Distance Pulse Count” by turning the knob or using the DOWN arrow key. Press the knob or ENTER key.

D02200605

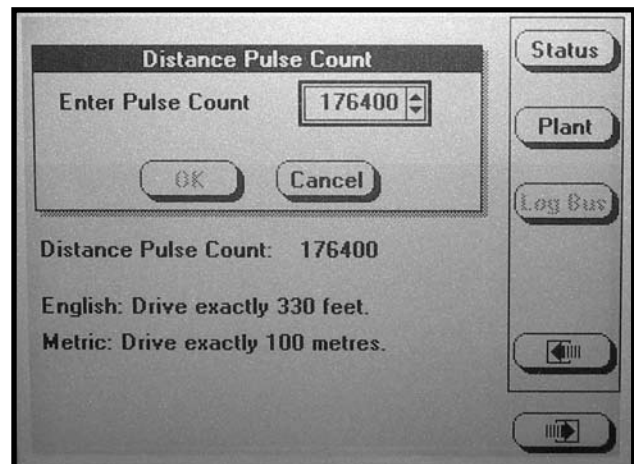

NOTE: The Distance Pulse Count will vary from the above example.

STEP 3 To return to “Planting Mode” press the PLANT key.

WHEN THE CORRECT DISTANCE PULSE COUNT IS KNOWN, CALIBRATION IS NOT NEEDED AND THE FOLLOWING STEPS MAY BE USED.

STEP 1 To enter the “Speed Sensor Calibration” screen, press F6 key until the “Mode Selection” screen appears. (If Applicable) Select “Setup Mode” and press the rotary encoder knob or ENTER key. Press F6 key to advance to the “Speed Sensor Calibration” screen.

STEP 2 Select “Change Distance Pulse” field by turning the knob or using the UP or DOWN arrow keys. Press the knob or ENTER key.

D02200605

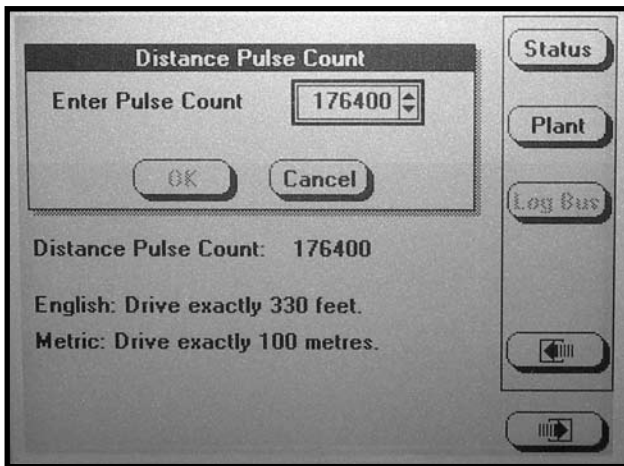

NOTE: The Distance Pulse Count will vary from the above example.

STEP 3 With the “Enter Pulse Count” field selected press the knob or ENTER key.

STEP 4 Change the Pulse Count to the desired value using the UP or DOWN arrow keys or turn the knob until the desired value is obtained. Press the knob or ENTER key.

NOTE: The LEFT arrow key multiplies the value of the item by 10 and the RIGHT arrow key divides the value of the item by 10.

STEP 5 Select OK by pressing the knob or ENTER key to save the new count. Select CANCEL to retain the old value of the Distance Pulse Count.

STEP 6 Press PLANT key to return to main planting screen.

REPROGRAMMING SPEED SENSOR

This setting must be specified when the monitor is first configured. It will be necessary to reprogram to use an alternate speed sensor.

NOTE: Speed sensors may not be changed while planting.

RADAR TO MAGNETIC DISTANCE SENSOR

STEP 1 Press the F6 key until the “Mode Selection” screen appears. Select “Setup Mode” by turning the rotary encoder knob or using the UP or DOWN arrow keys. Press the knob or ENTER key to display the highlighted item.

D02140614

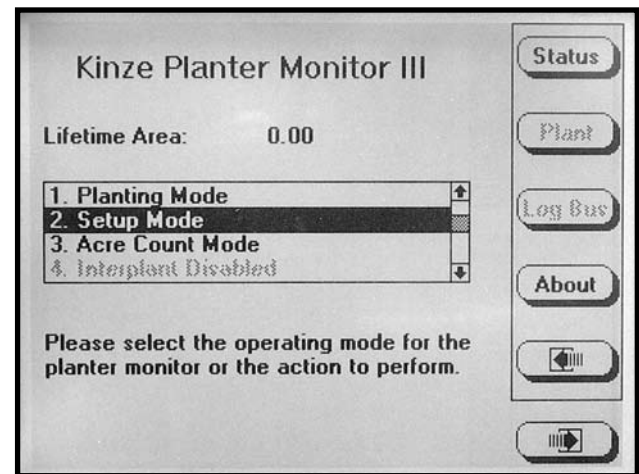

STEP 2 Turn the knob or use the UP or DOWN arrow keys to choose “Sensor Setup”. Press the knob or ENTER key to display the highlighted item.

D02140641

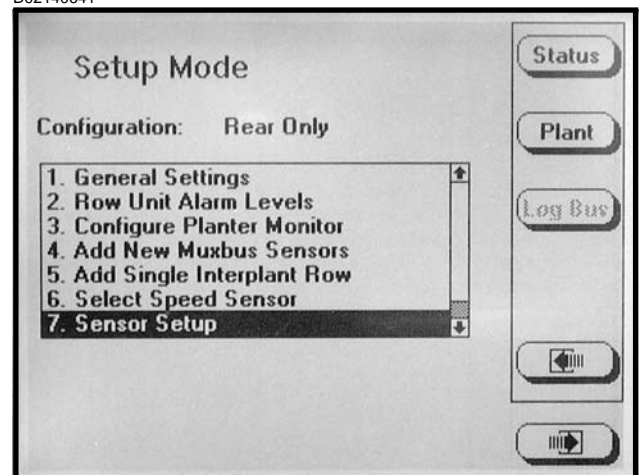

STEP 3 Turn the knob or use the UP or DOWN arrow keys to highlight “Mag Coil Pickup”. Plug in Magnetic Distance Sensor and press the INSTALL key. Press the knob or ENTER key to save information.

D05310609a

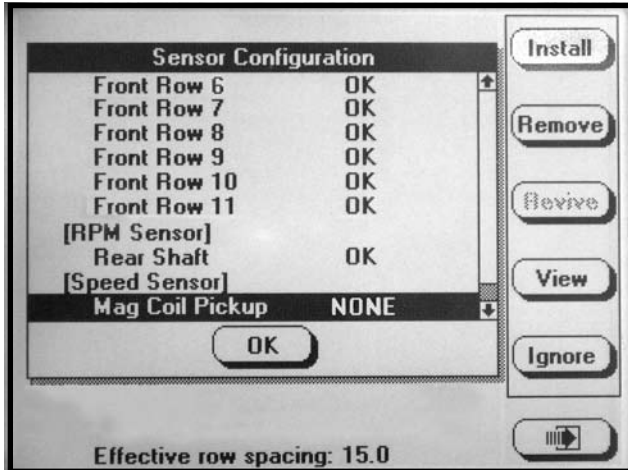

STEP 4 Turn the knob or use the UP or DOWN arrow keys to select “Select Speed Sensor” and press the knob or ENTER key. Press the knob or ENTER key to select the “Speed Sensor” field and a drop down menu will appear. Turn the knob or use the UP or DOWN arrow keys to select “Coil Pick-Up” and press the knob or ENTER key to make selection. The black box will advance to OK press the knob or ENTER key to save the information.

D02140639

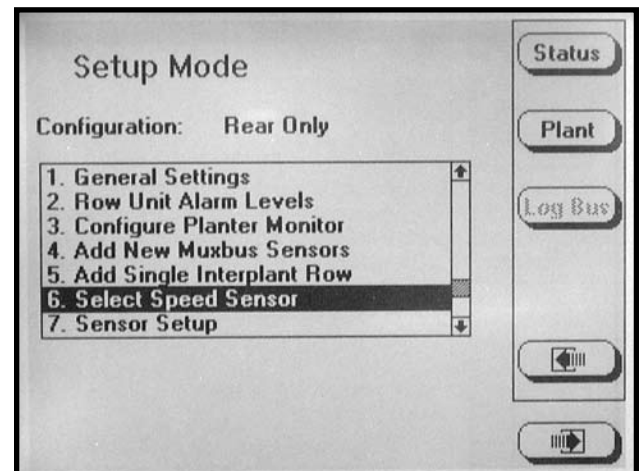

D05310609

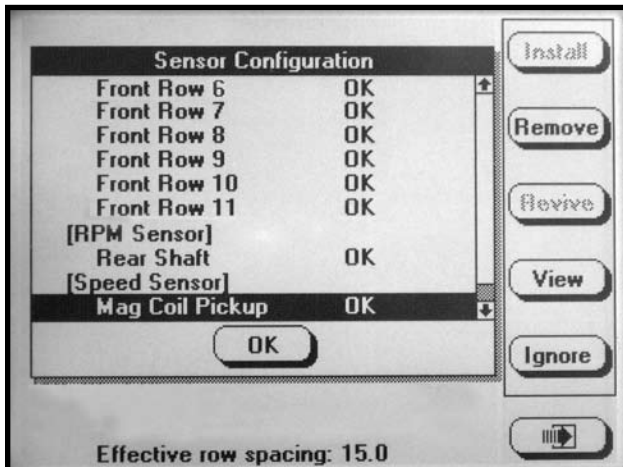

D02140639

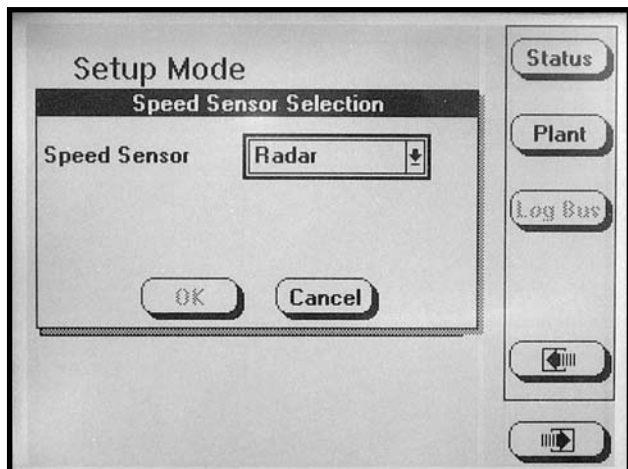

NOTE: To prevent the configuration from being changed select CANCEL, then press the rotary encoder knob, ENTER key or ESC key.

D06210601

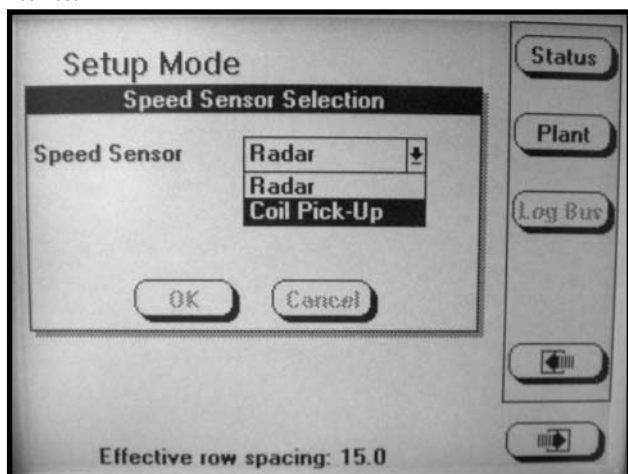

STEP 5 Unplug the radar from the tractor.

STEP 6 Press the PLANT key to return to main planting screen.

NOTE: When switching between speed sensors, verify the distance pulse count is correct for the chosen sensor. There will be significant distance pulse count variation between radar and coil pick-up sensors.

MAGNETIC DISTANCE SENSOR TO RADAR

STEP 1 Press the F6 key until the “Mode Selection” screen appears. Select “Setup Mode” by turning the rotary encoder knob or using the UP or DOWN arrow keys. Press the knob or ENTER key to display the highlighted item.

D02140614

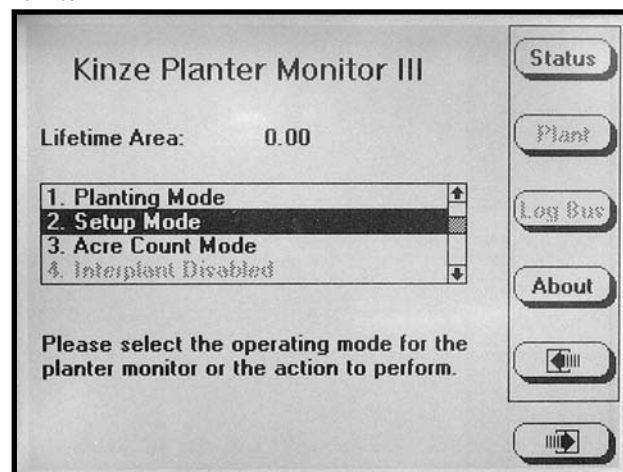

STEP 2 Turn the knob or use the UP or DOWN arrow keys to choose “Sensor Setup”. Turn the knob or use the UP or DOWN arrow keys to highlight “Mag Coil Pickup”. Press the REMOVE key, a note will appear for confirmation select as appropriate. Unplug Magnetic Distance Sensor and press the knob or ENTER key to save the information.

D02140641

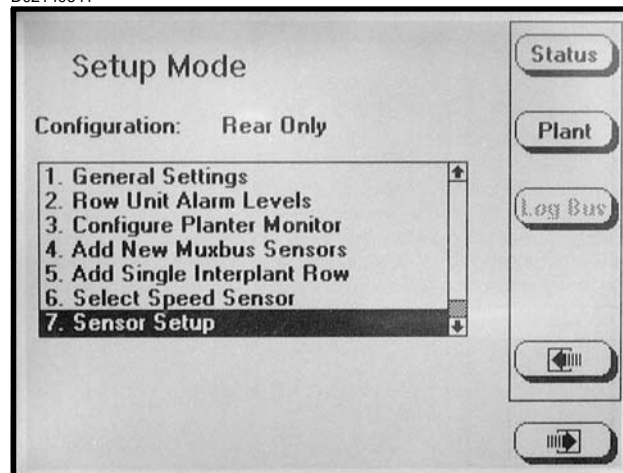

D05310609

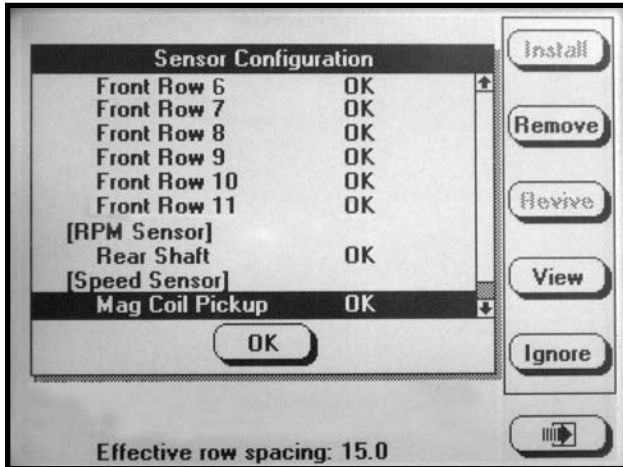

STEP 3 Turn the knob or use the UP or DOWN arrow keys to select “Select Speed Sensor” and press the knob or ENTER key. Press the knob or ENTER key to select the “Speed Sensor” field and a drop down menu will appear. Turn the knob or use the UP or DOWN arrow keys to select “Radar” and press the knob or ENTER key to make selection.

NOTE: To prevent the configuration from being changed select CANCEL, then press the knob, ENTER key or ESC key.

D02140640

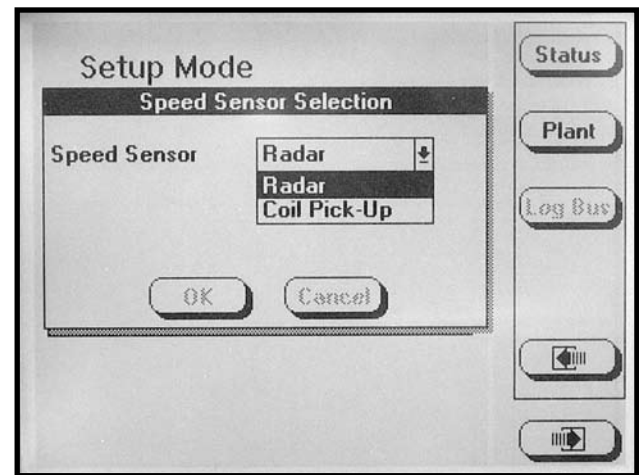

STEP 4 Plug in the Radar and the black box will advance to OK. Press the knob or ENTER key to save the information.

STEP 5 Press the PLANT key to return to main planting screen.

NOTE: When switching between speed sensors, verify the distance pulse count is correct for the chosen sensor. There will be significant distance pulse count variation between radar and magnetic distance sensors.

D02140639

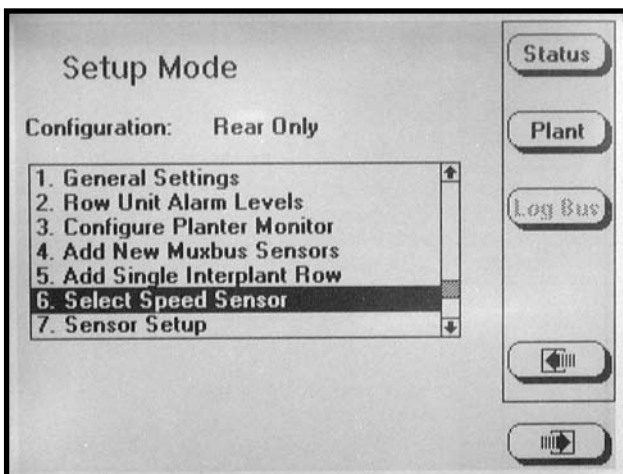

D02140639

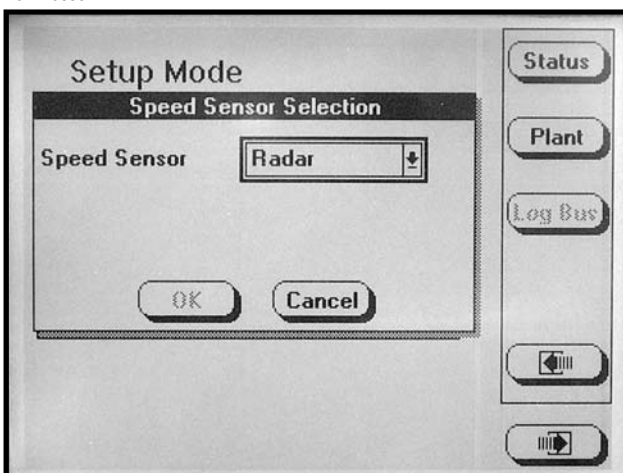

ADDING INTERPLANT® ROWS (If Rear Rows Have Previously Been Programmed)

STEP 1 Press the F6 key until “Mode Selection” screen appears.

STEP 2 Select “Setup Mode” by turning the rotary encoder knob or using the UP or DOWN arrow keys. Press the knob or ENTER key to display the highlighted item.

D02140614

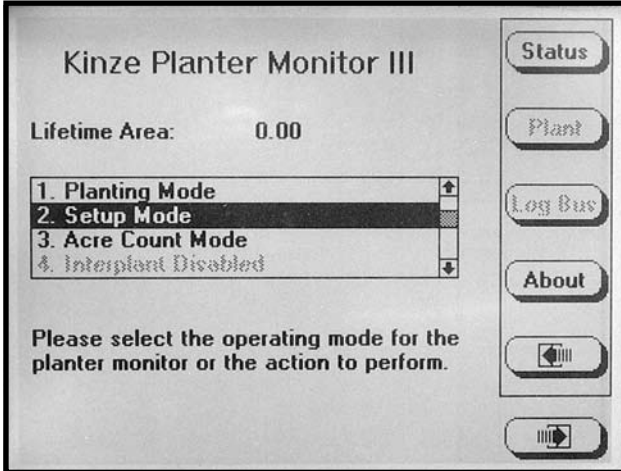

STEP 3 Select “Add New Muxbus Sensors” by turning the knob or using the UP and DOWN arrow keys. Press the knob or ENTER key to display the highlighted item.

D02140633

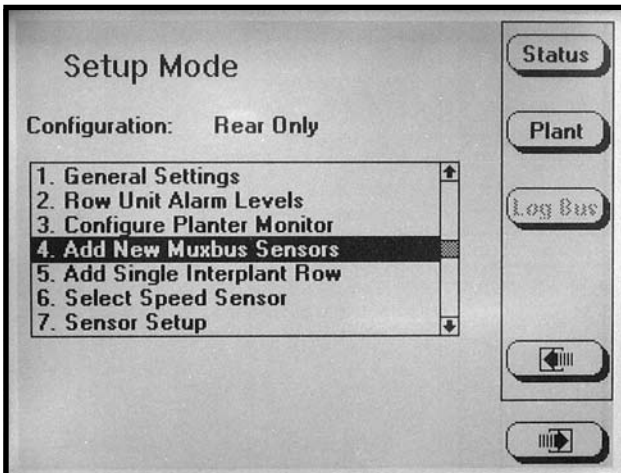

STEP 4 The note shown below will appear. Select OK by turning the knob or using the UP or DOWN arrow keys. Press the knob or ENTER key to make the selection.

D03010601

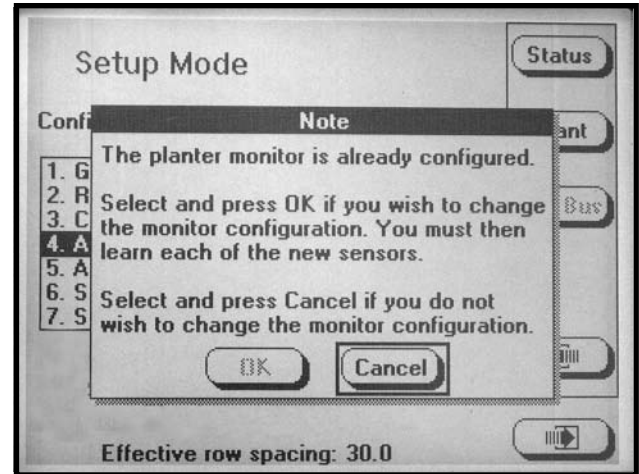

STEP 5 Turn the knob or use the UP or DOWN arrow keys to select the “Front Row Units” field and press the knob or ENTER key to highlight the field. Turn the knob or use the UP or DOWN arrow keys to obtain the desired number of rows. When the correct value has been entered press the knob or ENTER key. The black box will advance to the OK key. Press the knob or ENTER key to save the information.

NOTE: To prevent the configuration from being changed select CANCEL, then press the knob, ENTER key or ESC key.

D02220674

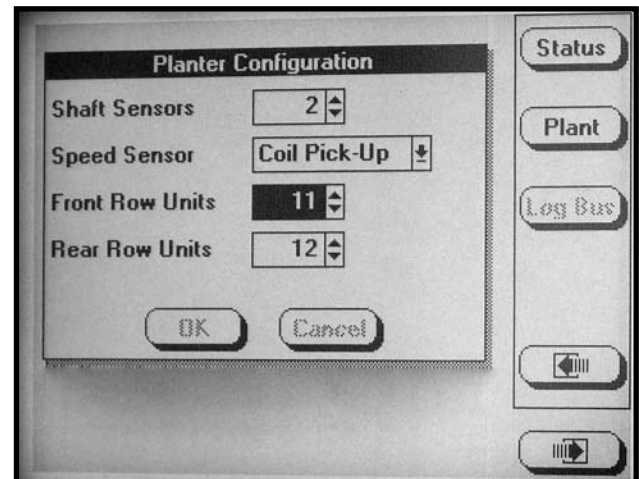

NOTE: Attempting to add rear rows while adding new muxbus sensors will cause the following note to appear.

D02220675

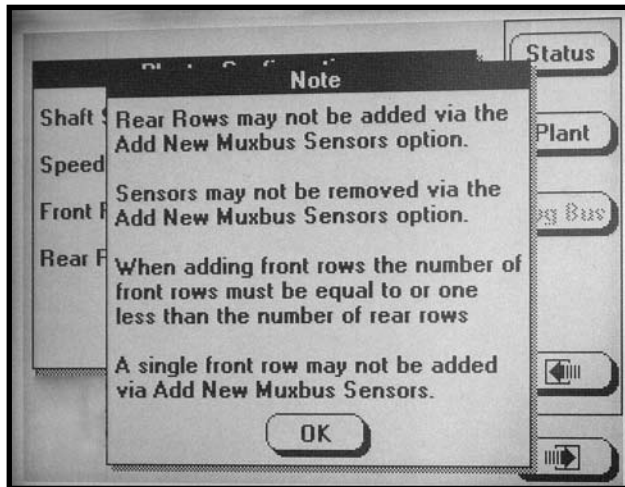

STEP 6 The note shown below will appear. Select OK by turning the knob or using the UP or DOWN arrow keys. Press the knob or ENTER key to make the selection.

D03010603

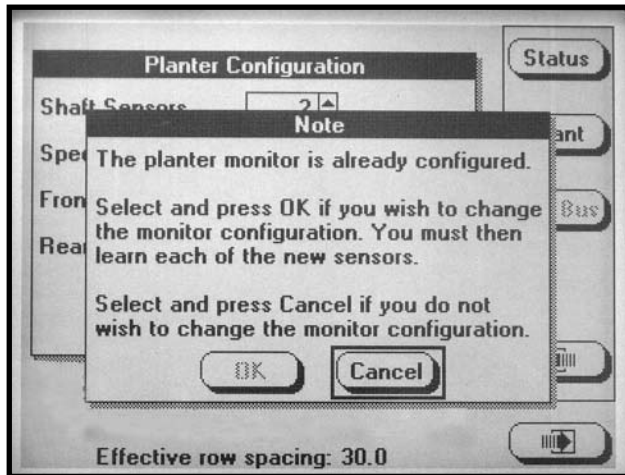

NOTE: To prevent the configuration from being changed select CANCEL, then press the knob, ENTER key or ESC key.

STEP 7 The sensor configuration screen will appear. With [Auto Detect] highlighted select INSTALL. Begin to install sensors from left to right.

D02230604a

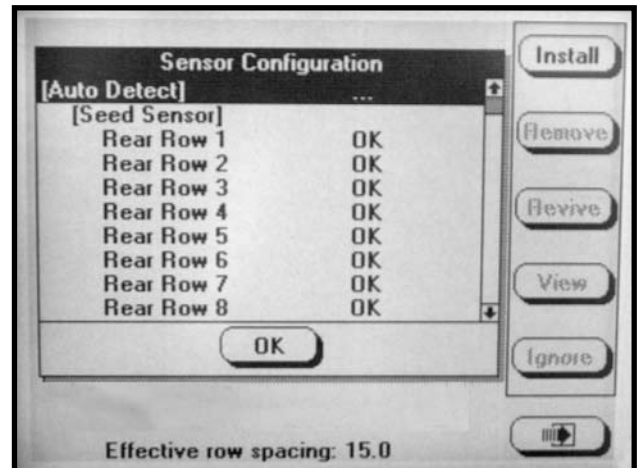

D02220672

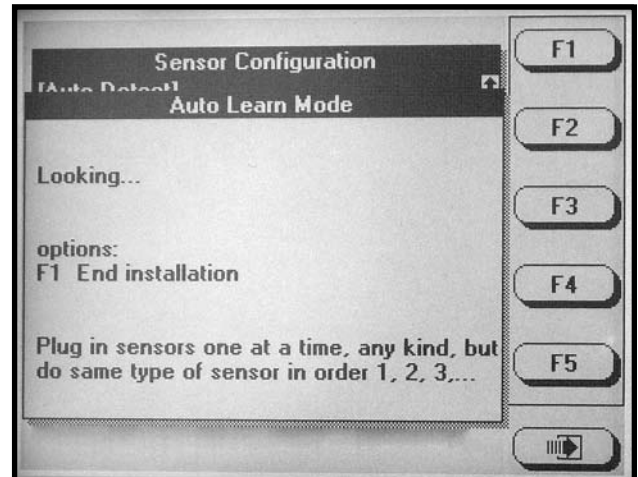

STEP 8 When all sensors are learned select F1 to end installation. Scroll down to verify the front rows are learned. Select OK by pressing the knob or ENTER key.

NOTE: "OK" will appear next to each sensor if no errors are detected.

STEP 9 Select “General Settings”, by turning the knob or using the UP or DOWN arrow keys. Press the knob or ENTER key to make the selection.

D02140615

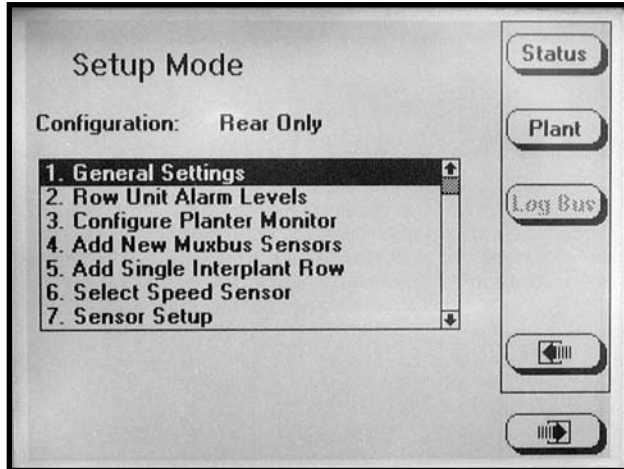

STEP 10 Select the “Row Spacing” field by turning the knob or using the UP or DOWN arrow keys. Press the knob or ENTER key to highlight field. Adjust the row spacing to Interplant spacing by turning the knob or using the UP or DOWN arrow keys. Press the knob or ENTER key to enter the value. Then turn the knob or use the UP or DOWN arrow keys to advance to OK. Press the knob or enter key to save row spacing.

NOTE: To prevent the configuration from being changed select CANCEL, then press the knob, ENTER key or ESC key.

STEP 11 To return to “Planting Mode” press the PLANT key.

ADDING EVEN-ROW PACKAGE (If Front Rows Have Previously Been Programmed)

STEP 1 Press the F6 key until “Mode Selection” screen appears.

STEP 2 Select “Setup Mode” by turning the rotary encoder knob or using the UP or DOWN arrow keys. Press the knob or ENTER key to display the highlighted item.

D02140614

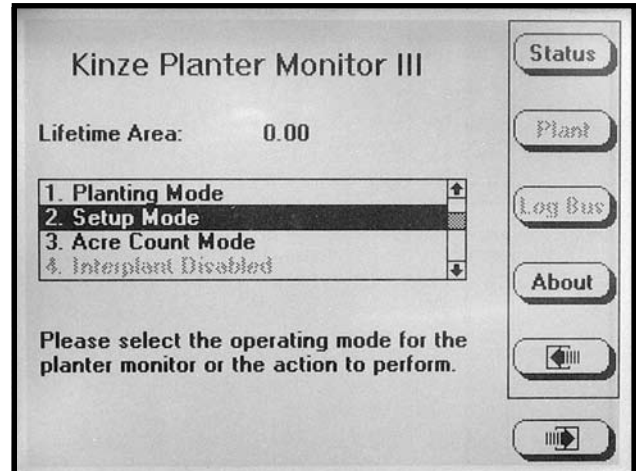

STEP 3 Select “Add Single Interplant Row” by turning the knob or using the UP and DOWN arrow keys. Press the knob or the ENTER key to display the highlighted item.

D022206200

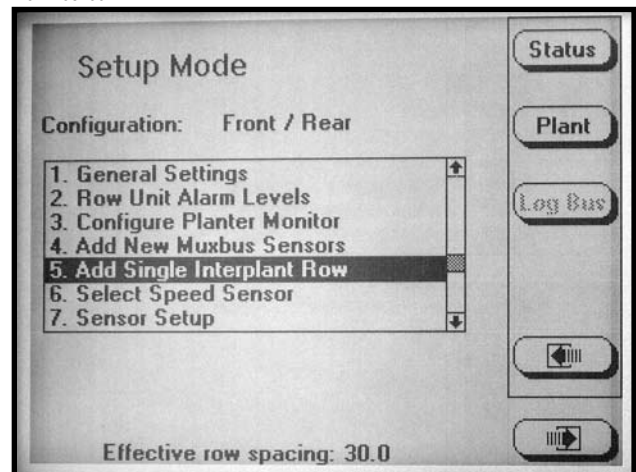

STEP 4 To confirm the following note turn the knob or use the UP or DOWN arrow keys to select OK and then press the knob or ENTER key to confirm. If the single Interplant row is not to be added select the CANCEL key and press the knob or ENTER key to cancel or press the ESC key.

D022206201

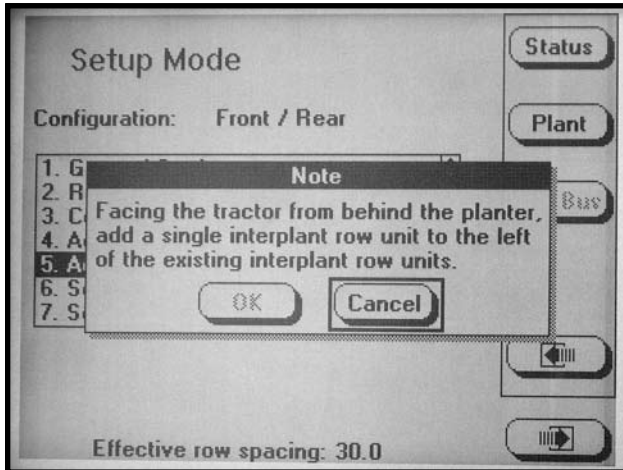

STEP 5 To “Add Single Interplant Row” the following screen will appear.

If the single Interplant row is to be added turn the knob or use the UP or DOWN arrow keys to select OK and then press the knob or ENTER key to add the Interplant row. If the single Interplant row is not to be added select the CANCEL key and press the knob or ENTER key to cancel or press the ESC key.

D022206202

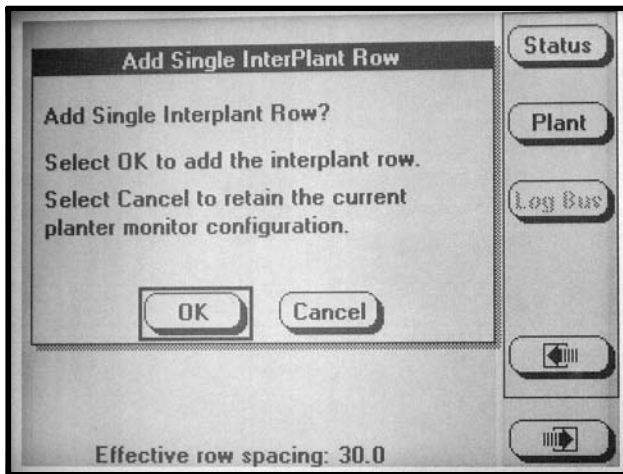

STEP 6 The “Sensor Configuration” screen will appear. Plug in the new sensor then scroll down to highlight “Front Row 1” by turning the knob or using the UP or DOWN arrow keys. Select INSTALL to learn the new sensor. Press the knob or ENTER key to return to setup mode.

D02220670

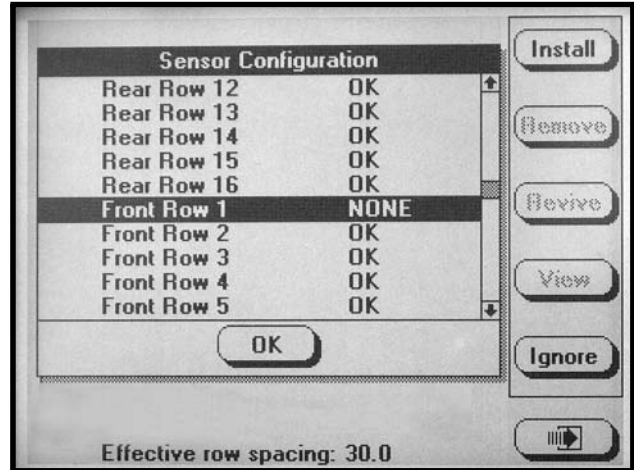

STEP 7 To return to “Planting Mode” press the PLANT key.

ENABLING/DISABLING INTERPLANT® ROWS

To Enable or Disable Interplant (a) press the F6 key until the “Mode Selection” screen appears, (b) turn the rotary encoder knob or use the UP or DOWN arrow keys to highlight “Disable/Enable Interplant”, (c) press the knob or ENTER key to “Disable” or “Enable” Interplant. To verify selection, the row spacing is displayed on the bottom of the screen.

D03010605a

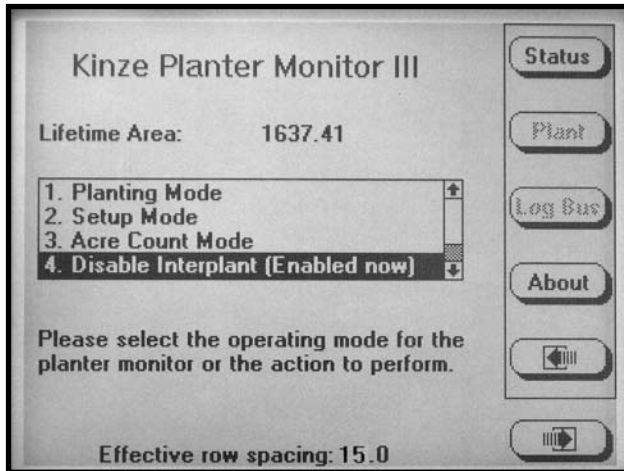

Either select the “Planting Mode” by turning the knob or using the UP arrow key and press the knob or ENTER key or press F6 to return to the “Planting Mode”.

D02240602

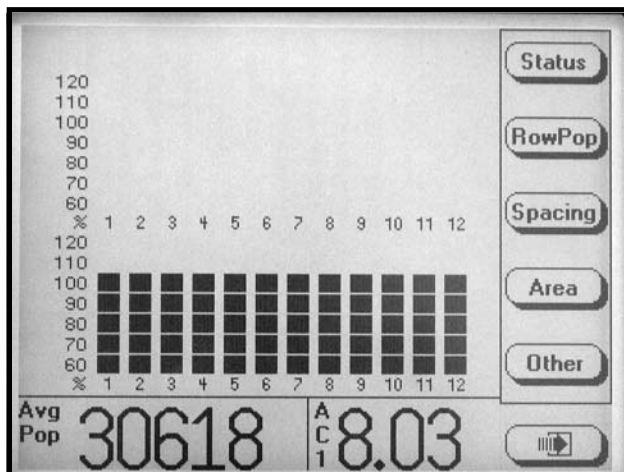

ROW POPULATION

- Press the ROW POP key to display row population. Average planter population will be shown in the lower L.H. corner of the display.

D05310614

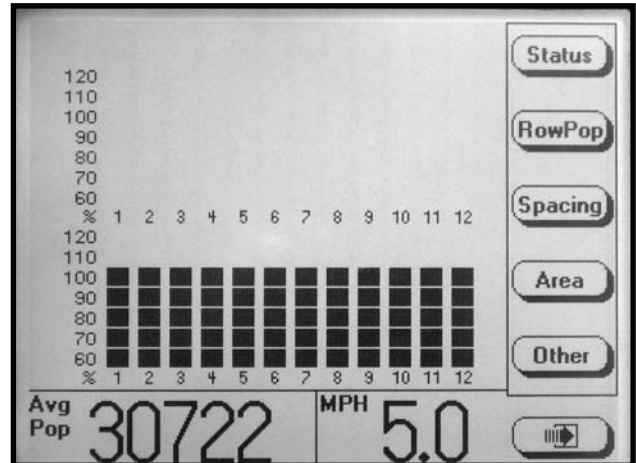

- Press the SCAN key and the monitor will scan through each row in ascending order displaying the average seed population for each row. After all rows have been scanned the average population is displayed and scan function will continue with the first rear row.

D02240604

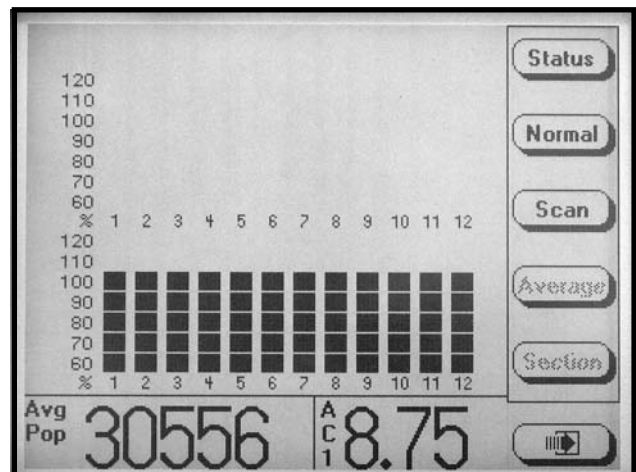

- Press the FREEZE key to stop scanning, the left display item will be frozen on a particular row. "Frzn" appears in the lower L.H. corner to indicate the display is frozen. To resume scan press the SCAN key.

EXAMPLE: When average row population is shown, R3 indicates rear row 3, F2 indicates front row 2, etc.

D05310615

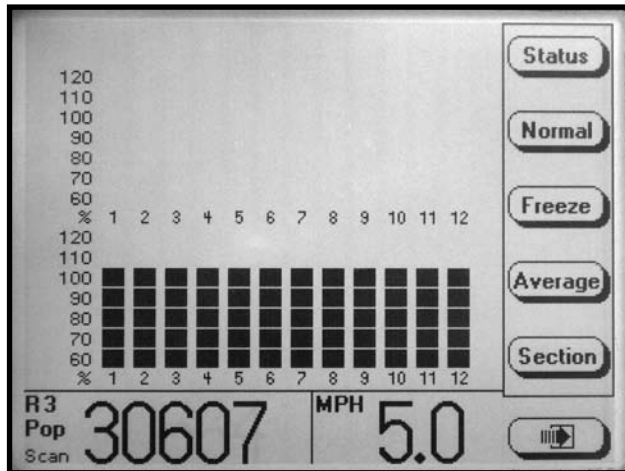

- When either Scan or Frzn is displayed in the L.H. corner the SECTION and arrow keys function as follows: (a) SECTION or RIGHT arrow key advances to the first row of the next section; (b) SECTION or LEFT arrow key selects the first row of the previous section, wrapping around to the first row of the last section when moving past the first section; (c) UP arrow key moves forward to the next row of the planter, wrapping around to the first row when moving past the last row; (d) DOWN arrow key moves backward to the previous row of the planter, wrapping around to the last row of the planter when moving past the first row.
- Press the AVERAGE key to display the average population in the bottom L.H. corner.
- Press the NORMAL key to display the normal screen for planting mode.

NOTE: If the rows are being scanned and the AVERAGE key is selected the scan function will stop.

ROW SPACING

- Press the SPACING key to display seed spacing keys. Seed spacing will appear in the bottom L.H. corner of the display.

D02240602

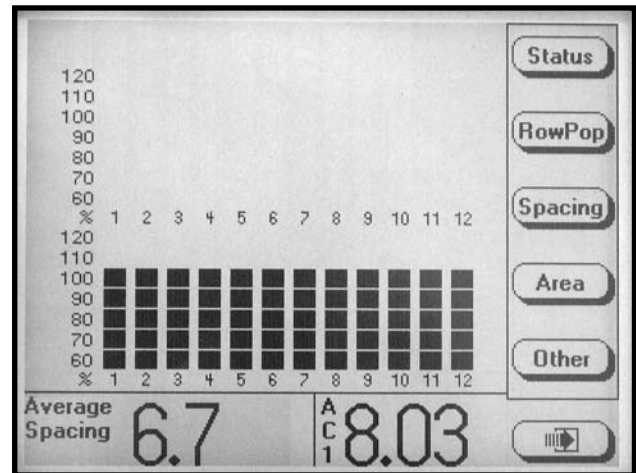

D02240605

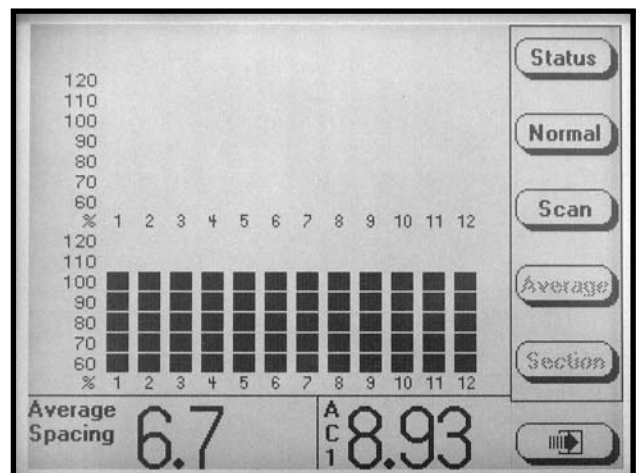

- Press the SCAN key and the monitor will scan through each row in ascending order displaying the average seed spacing for each row. Scan appears in the L.H. corner to indicate the display is scanning. After all rows have been scanned the average population is displayed and scanning will continue with the first rear row.
- Press the FREEZE key to stop scanning and the left display item will be frozen on a particular row. "Frzn" appears to indicate the display is frozen. To resume scan press the SCAN key.

- When either "Scan" or "Frzn" is displayed in the left display item the SECTION and arrow keys function as follows: (a) SECTION and RIGHT arrow key advances to the first row of the next section; (b) LEFT arrow key selects the first row of the previous section, wrapping around to the first row of the last section when moving past the first section; (c) UP arrow key moves forward to the next row of the planter, wrapping around to the first row when moving past the last row; (d) DOWN arrow key moves backward to the previous row of the planter, wrapping around to the last row of the planter when moving past the first row.

- Press the AVERAGE key to display the average seed spacing in the bottom L.H. corner.
- Press the NORMAL key to display the main planting mode.

NOTE: If the rows are being scanned and the AVERAGE key is selected the scan function will stop.

SPEED/SHAFT ROTATION

- Press the OTHER key to display items available to display in the bottom R.H. corner.

- Press the SHAFT key to view the average meter shaft RPM. The value will appear in the bottom R.H. corner of the display.

NOTE: Applicable to planters with shaft rotation sensors installed.

D02240607

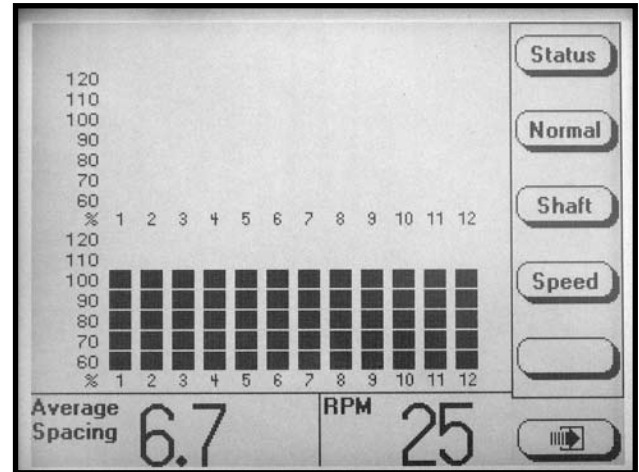

- Press the SPEED key to view the ground speed. The value will appear in the bottom R.H. corner of the display.

D02240602

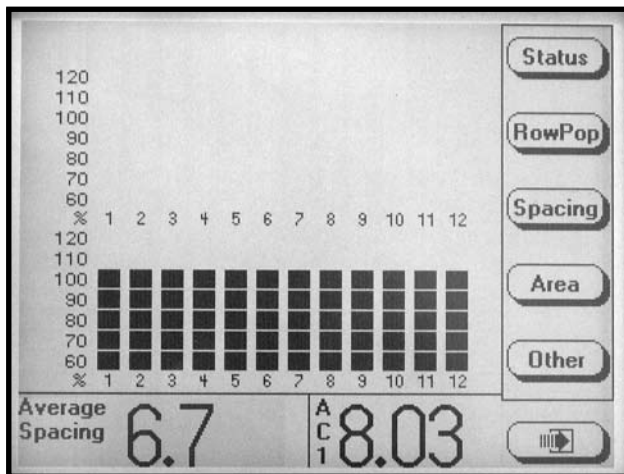

D02240608

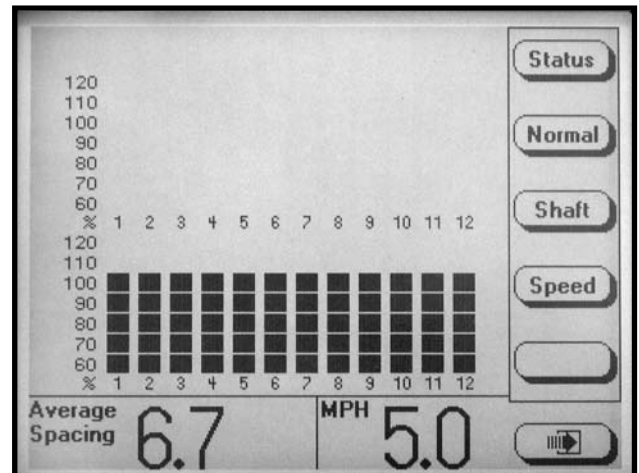

NOTE: The appropriate units of measure will be displayed (English or Metric).

- Press NORMAL to bring back the standard key labels.

D02240606

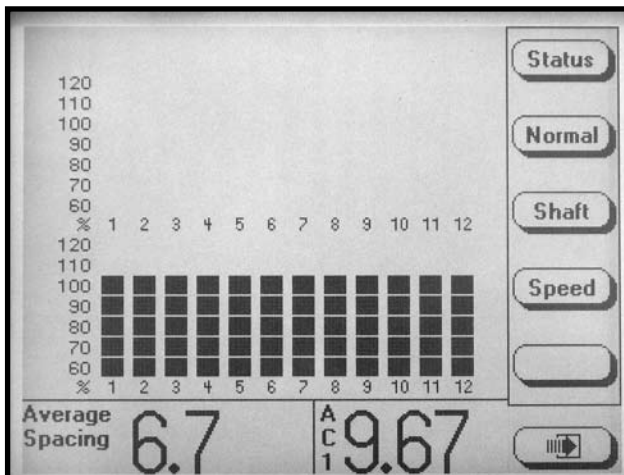

WARNINGS AND ALARMS

1. **Seed Rate Alarm** - A seed rate alarm is activated whenever the row average seed population drops below the threshold set for that row.

The corresponding row on the bargraph starts flashing and the monitor emits a series of beeps that persist until the alarm is clear or the ACK button is pressed. "Seed Rate Alarm" appears in the upper left corner of the screen. The bargraph for the row drops down based on the threshold set for the alarm.

EXAMPLE: If the threshold is 70% the lower two bargraph segments are shown. If the threshold is 50% or 10% the lowest bargraph segment is shown.

The status message associated with an alarm contains more information about the alarm. To view the "Status Message" for a seed rate alarm, press the STATUS key.

If the sensor is detecting no seed flow it will display which row is not functioning. The alarm may be indicating a mechanical problem that is reducing the seed flow or an electrical problem causing the seed counts to be incorrect.

NOTE: The only way to remove an alarm is to find and correct the problem. Alarms are not reported for rows that seed rate alarm thresholds have been disabled.

NOTE: The percentage shown in the alarm message is the percentage at the time the alarm occurred.

2. **Section Not Planting** - When the monitor detects an entire section not planting, the monitor will emit three beeps to alert the user. The bargraph for the affected section flashes and is reduced to the lowest segment. An alarm message is added to the list of "Status Messages". Press the STATUS key to view the alarm message.

3. **Seed Counting Sensors Not Communicating With Monitor** - When the monitor detects a communication error between the sensor and the monitor, the monitor will emit two beeps to alert the user. Try to reestablish communication with sensor(s) by pressing F2. If the monitor is unable to establish communication there may be (a) a faulty sensor, (b) a poor electrical connection or (c) a cut or pinched wire harness.

D02220687

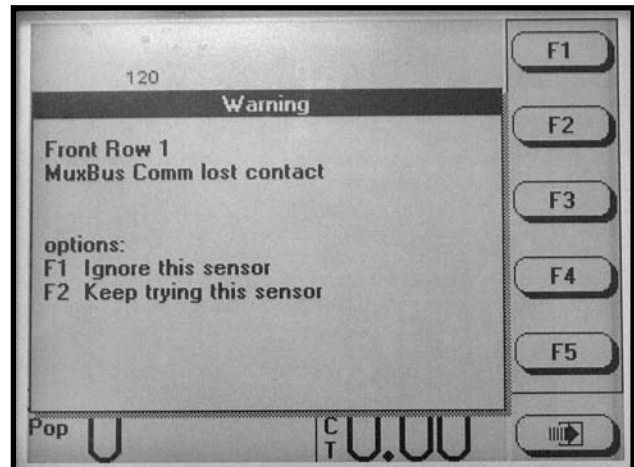

If multiple sensors have lost contact, the message will indicate which sensors have lost contact.

D02220659a

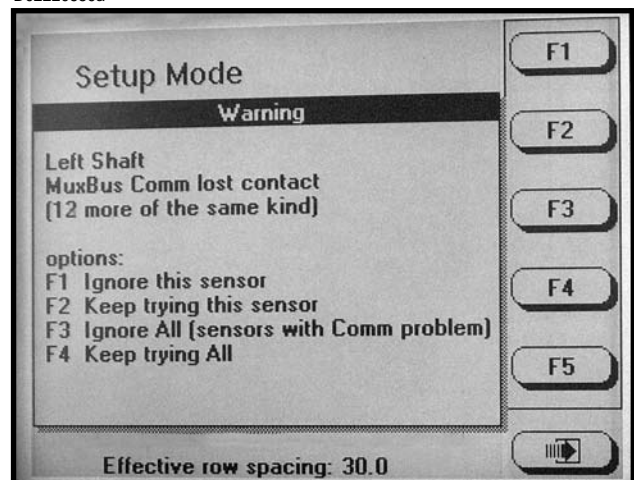

NOTE: When it is known that a sensor or a group of sensors are faulty, F1 or F3 should be pressed. The monitor will no longer try to communicate with the sensor(s). In the planting mode the corresponding bargraphs will be grayed out in the main screen.

D02220691



NOTE: If the sensors are not faulty, F2 or F4 should be pressed and the message shown below will appear when the STATUS key is pressed.

D02220685

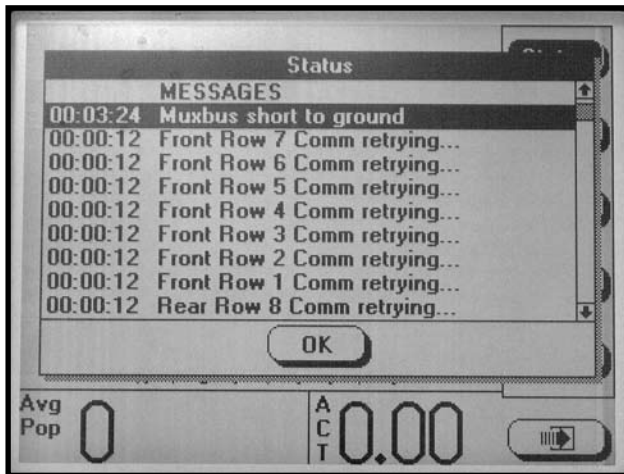

NOTE: If a sensor has been ignored, the sensor configuration screen will display as shown below.

D02220692

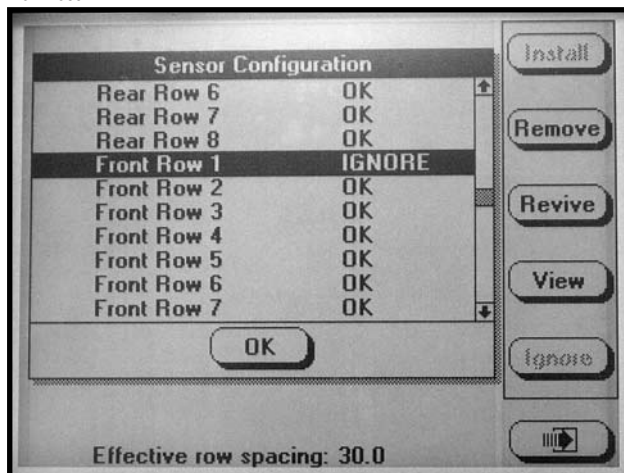

- Seed Counting Sensors Too Dirty Warning** - When powering on the KPM III, each of the seed sensors will do a self check. If a seed tube is too dirty, the message “Clean Or Replace Sensor As Necessary” will be displayed and the bargraph for that row will flash. The LED on the seed tube sensor will not flash. The sensor will not function until the problem is corrected.

NOTE: After the alarms have been acknowledged and if the alarm condition is still present, the LCD screen will continue to display the alarm condition.

- Wire Shorts** - When a wire is shorted any one of the messages shown below will appear, stating which wires are shorted. The short must be located and fixed to continue planting. Cycle the power on the monitor to clear the alarm.

D02220683

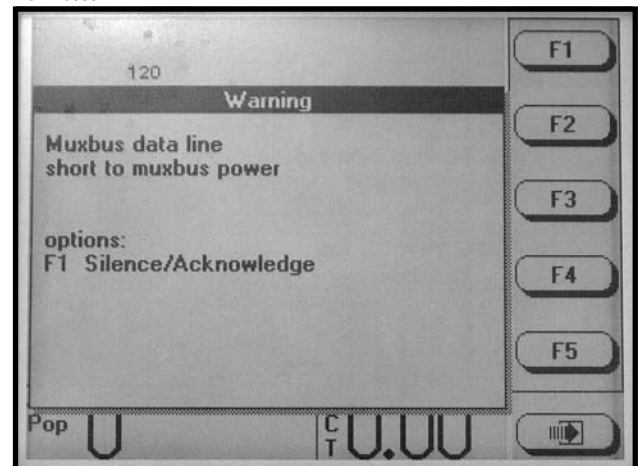

D02220684

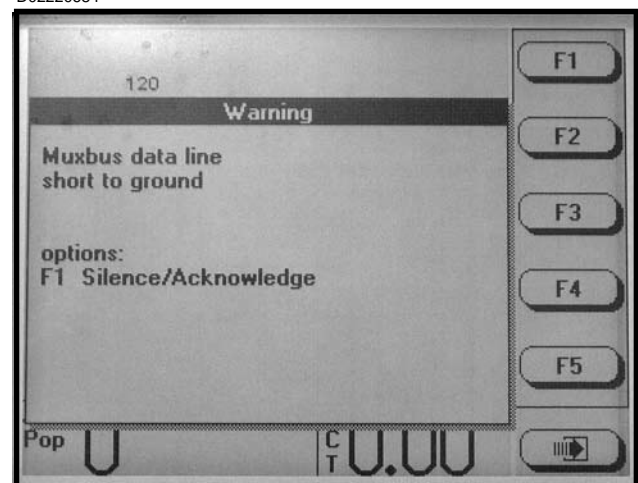

FIELD OPERATION

Press the ON/OFF key to turn the monitor ON.

If the monitor has been configured, it will enter the normal planting mode and attempt to communicate with the seed sensors.

D02200606

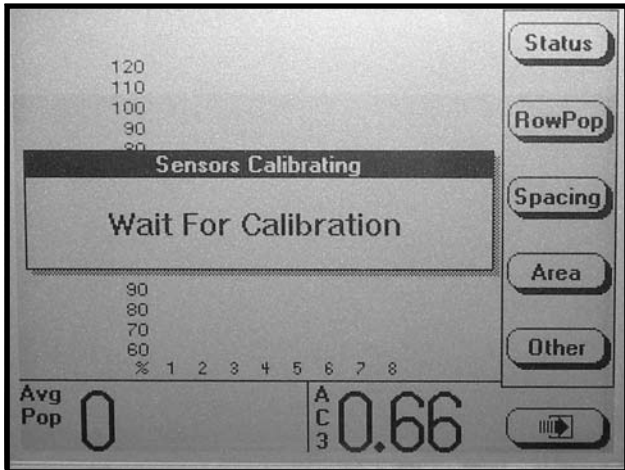

NOTE: Do not attempt planting before the “Wait For Calibration” message disappears. If planter is moving while sensors are calibrating alarms will be generated.

NOTE: If the monitor can communicate with the sensors the normal planting mode screen will be displayed.

D02220689a

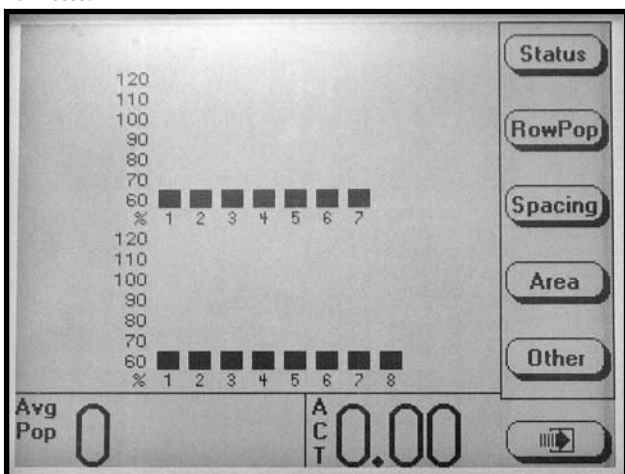

If the monitor does not detect any sensors the message shown below will appear.

D02200627

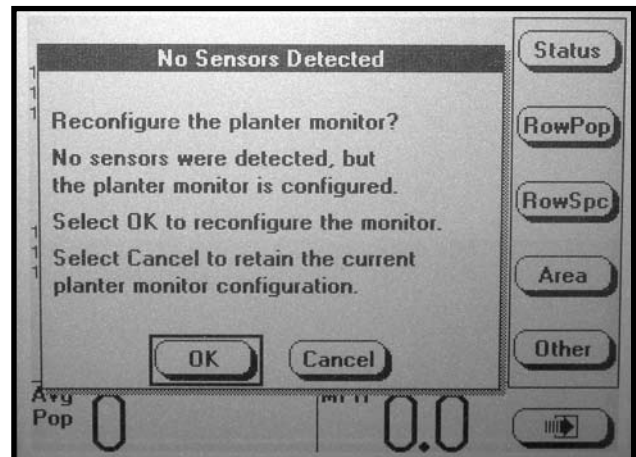

NOTE: Selecting OK will reconfigure the monitor requiring all sensors to be re-learned. Selecting CANCEL will maintain the current configuration and the monitor will continue trying to communicate with the sensors.

AREA MANAGEMENT

There are 10 area counters: Total Area, Field Area and area counters 1 through 8. The Total Area is always active but may be cleared. If it is cleared, the Field Area is also cleared. Field Area and Area Counters 1 through 8 may be cleared independent of each other. They may also be started or stopped at anytime. In addition, there is a Lifetime Area Counter (located on the Mode Selection Screen) which can not be disabled or cleared by the user.

To enter the "Area Management" screen, press the F6 key until the "Area Management" screen appears.

D02210626a

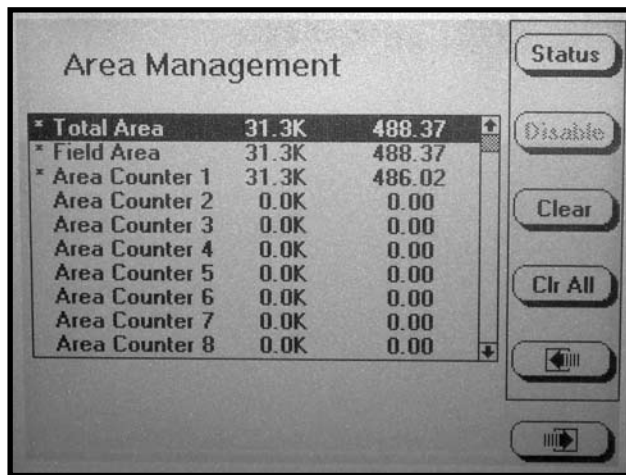

NOTE: Total area counter can never be disabled, but can be reset to zero (cleared).

- The asterisk next to the name of the area counter indicates the area counter is enabled and accumulating area.

EXAMPLE: In the photo shown above, 31.3K indicates the average seed population for the accumulated area is 31,300 seeds per unit area (acre/hectare). This number has been rounded off. The actual seed population ranges anywhere from 30,500 to 31,499 per unit area. The last column of numbers is the area accumulated (acres/hectares).

- Turn the knob or use the UP or DOWN arrow keys to highlight the desired "Area Counter".
- Press the ENABLE or DISABLE key.

NOTE: Up to four area counters can be enabled at one time (two area counters in addition to Total Area and Field Area). If four area counters are already enabled, disable one active area counter in order to enable a new area counter. To disable or enable area counters see next column.

NOTE: When a key is dimmed it does not perform any operation on the highlighted area counter.

ENABLE AREA COUNTER

Each of the "Disabled Area Counters" may be enabled up to a total of four "Area Counters". To Enable a Disabled "Area Counter": (a) highlight the desired "Area Counter" by turning the rotary encoder knob or using the UP or DOWN arrow keys; (b) press the ENABLE key or press the knob or ENTER key and an asterisk will appear next to the "Area Counter". The Enabled "Area Counter" starts accumulating area.

DISABLE AREA COUNTER

Each of the Enabled Area Counters may be disabled, with the exception of the Total Area Counter. To disable an enabled area counter: (a) highlight that "Area Counter"; (b) press the DISABLE key or press the rotary encoder knob or ENTER key and the asterisk next to the "Area Counter" will disappear. The "Disabled Area Counter" will no longer accumulate area.

NOTE: Attempts to disable an Area Counter that is currently being displayed while planting will cause the following alarm.

D02210627a

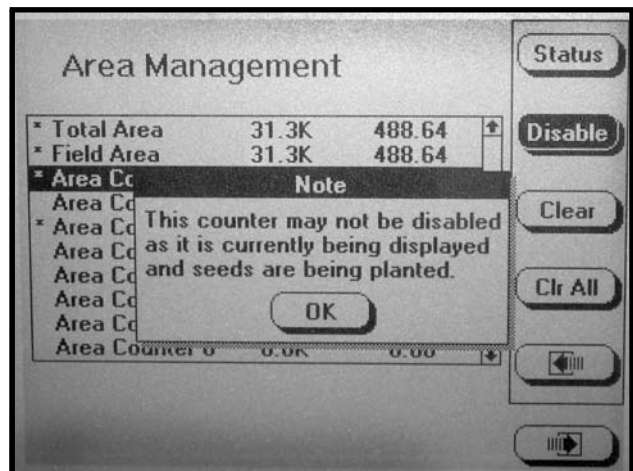

D02210626a

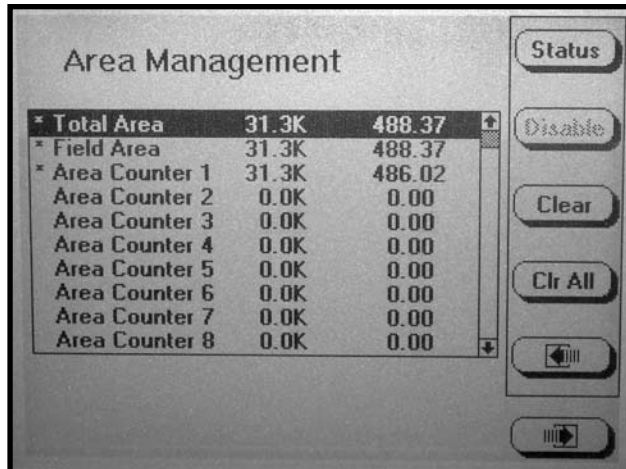

NOTE: If the total area is highlighted and the CLEAR key is pressed the following request for confirmation will appear.

D02200612

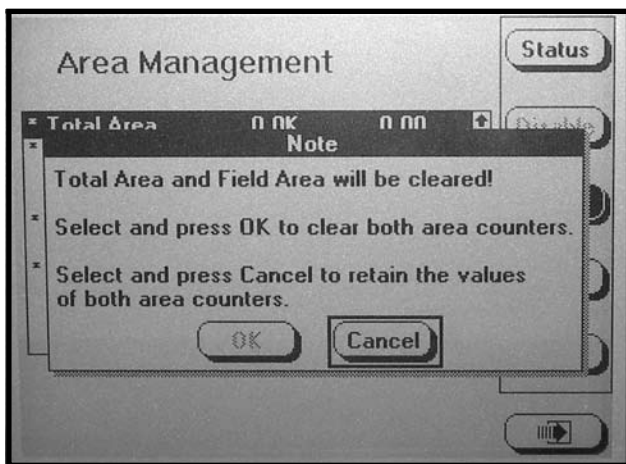

CLEAR AREA COUNTER

Total Area, Field Area and Area Counters 1 through 8 can be cleared, whether they are Enabled or Disabled. Clearing the "Total Area" counter forces the "Field Area" counter to also be cleared. Clearing any other "Area Counter" including the "Field Area" counter clears only that counter.

NOTE: Lifetime Area Counter can never be cleared or disabled.

To clear an Area Counter: (a) highlight the desired area counter, by turning the rotary encoder knob or using the UP or DOWN arrow keys, (b) press the CLEAR key, (c) the request for confirmation shown below will appear, (d) turn the knob or use the UP or DOWN arrow keys to select OK or CANCEL, (e) press the knob or ENTER key to make selection.

To Clear All Area Counters except the "Total Area Counter": (a) select the CLR ALL key; (b) a request for confirmation will appear; (c) turn the knob or use the UP or DOWN arrow keys to select either OK or CANCEL; (d) press the knob or ENTER key to confirm selection.

D02210628

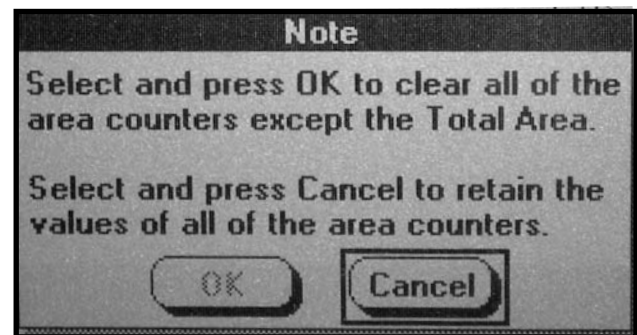

AREA COUNTERS

STEP 1 On the main planting screen press the AREA key.

D02240602

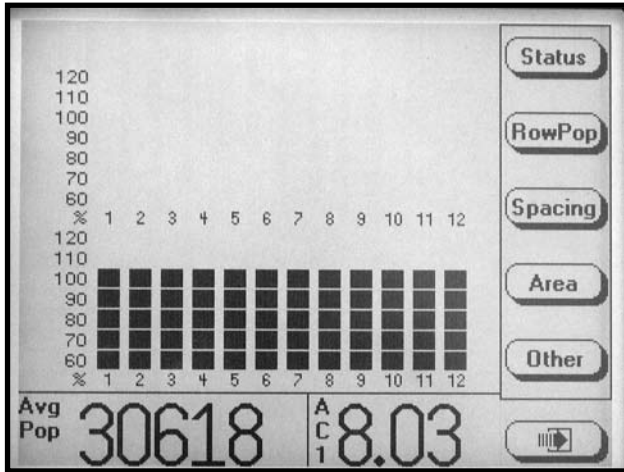

STEP 2 Press the SELECT key to display the list of the Enabled Area Counters.

D02240603

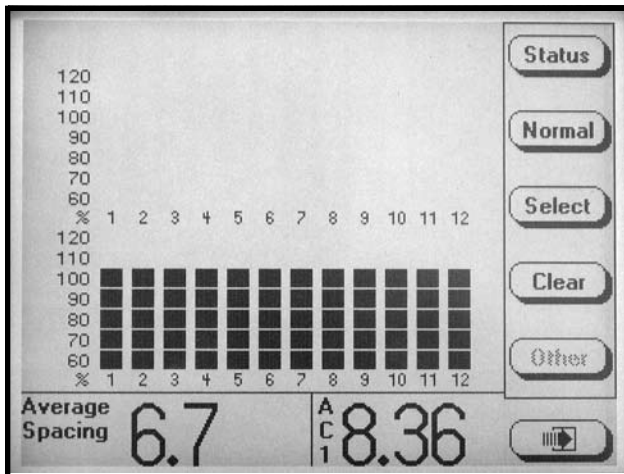

STEP 3 To select the desired active "Area Counter" turn the knob or use the UP or DOWN arrows to highlight the desired "Area Counter".

D02240609

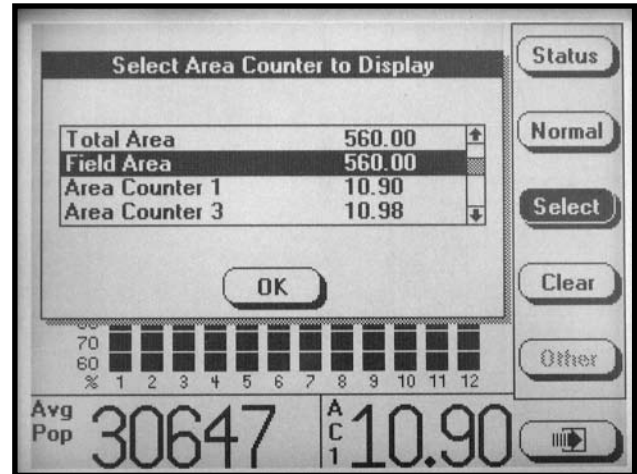

STEP 4 Press the knob or ENTER key to select OK. The planting screen will then be displayed. Press NORMAL to display main planting screen.

D02240610

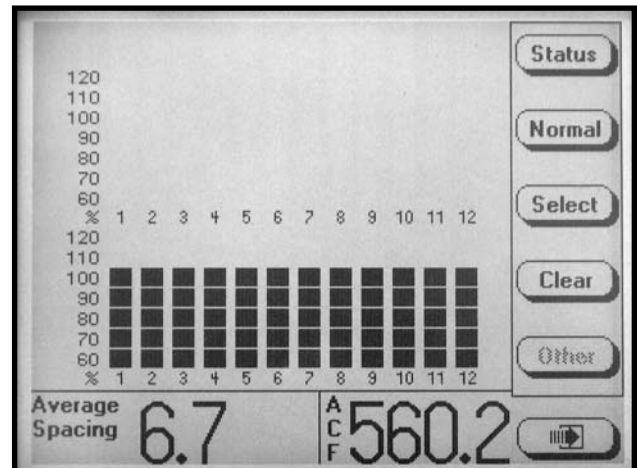

NOTE:The abbreviation for the selected area counter numerical value will appear in the bottom R.H. corner of the screen. In the above photo "ACF" represents "Area Counter Field".

CLEARING FIELD AREA

To reset the counter, display the main planting screen by pressing the F6 key until it appears. Press the AREA key then select the CLEAR key, a dialog box will appear requesting confirmation to clear. Select OK or CANCEL key by turning the rotary encoder knob or using the UP or DOWN arrow keys. Press the knob or ENTER key to verify the selection.

D02210625

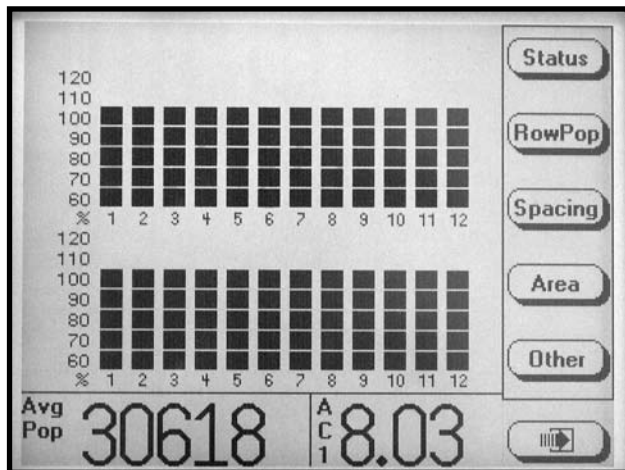

D02210625

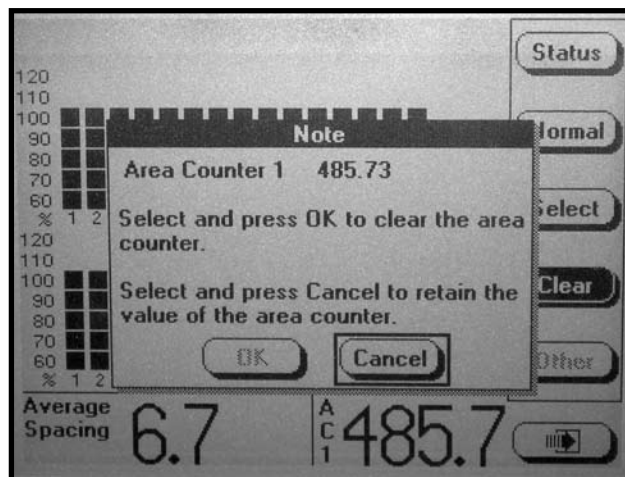

NOTE: Only the displayed Area Counter can be disabled.

ACRE COUNT MODE

When a tractor is equipped with a radar distance sensor, accumulating area without a planter attached is possible. Two routes are provided to enter acre count mode: (a) Installation of an Acre Count Switch Kit or (b) entry into Acre Count Mode.

Acre Count Switch Kit

STEP 1 With the monitor OFF, attach an Acre Count Switch Kit to the Muxbus connector and then turn monitor ON and advance to STEP 2.

Acre Count Mode

STEP 1 Press the F6 key until the "Mode Selection" screen appears. Turn the rotary encoder knob or use the UP or DOWN arrow keys to select "Acre Count Mode". Press the knob or ENTER key.

D02200618

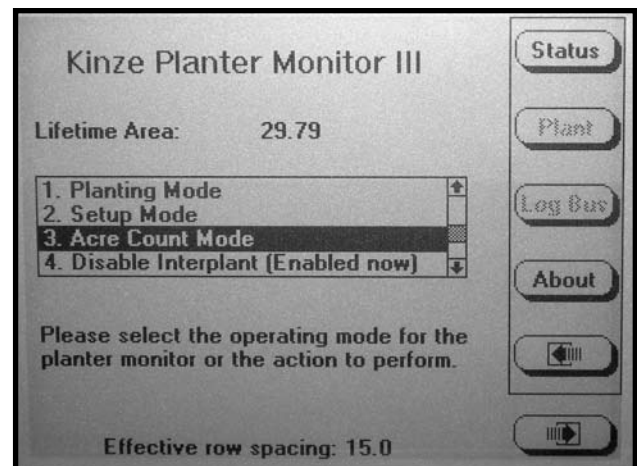

NOTE: If no radar unit is detected a warning will appear.

NOTE: If using acre count mode, acre (acres or hectares) is accumulated in "Lifetime Area Counter".

NOTE: DO NOT BEGIN ACCUMULATING AREA IF THE RADAR UNIT HAS NOT BEEN CALIBRATED. Always check the distance pulse count value immediately after entering acre count mode and before pressing start.

STEP 2 In the menu, “Units & Width” will be highlighted. Press the knob or ENTER key.

D02200619

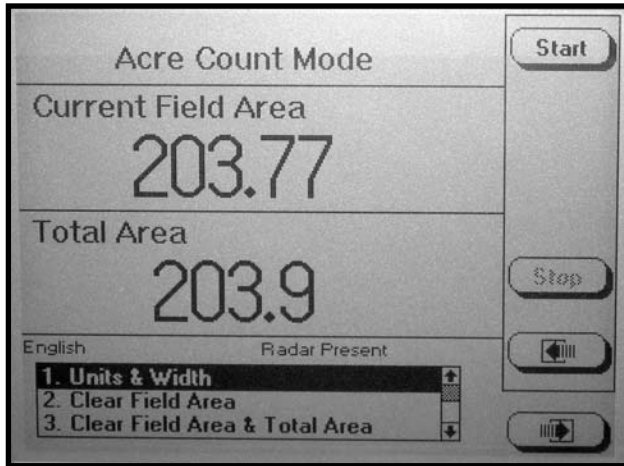

STEP 3 A drop down menu will appear. Select the correct units of measure “English” or “Metric” by turning the knob or using the UP or DOWN arrow keys. Press the knob or ENTER key to make the selection. The black box will advance to “Implement Width” field showing implement width in feet.

D02200621



STEP 4 Press the knob or ENTER key to highlight the field. Turn the knob or use the UP or DOWN arrow keys to select desired number in feet. When desired number is obtained press the knob or ENTER key. The black box will advance to OK key.

NOTE: The implement width entered in acre count mode has no effect on planting mode settings.

STEP 5 Press the knob or ENTER key when done.

NOTE: Tractor should be at a complete stop before starting.

STEP 6 To begin accumulating area press the START key.

STEP 7 To stop accumulating area or to move to a different location, press the STOP key.

There are two counters in the Acre Count Mode (Field Area Counter and Total Area Counter). The “Field Area” counter can be cleared independent of the “Total Area” counter. Clearing the “Total Area” counter causes the “Field Area” counter to also be cleared.

- **To Clear Field Area.** Highlight “Clear Field Area” and press the knob or ENTER key. A note will appear verifying the decision to reset the field area to zero. Select OK and press the knob or ENTER key to clear the field to zero. Select Cancel and press the knob or the ENTER key to retain the current field value.

- **To Clear Both Field Area And Total Area.** Highlight the “Clear Field Area & Total Area” and press the knob or ENTER key. A note will appear to verify the decision to reset the field area and the total area to zero. Select OK and press the knob or ENTER key to clear the field to zero. Select CANCEL and press the knob or ENTER key to retain the current field value.

With planter reconnected to monitor return to normal plant screen by pressing the F6 key until the “Mode Selection” screen appears. Select “Planting Mode” by turning the knob or using the UP or DOWN arrow keys, press the knob or ENTER key.

REPLACING FAULTY SENSOR(S)

To replace a single faulty sensor: (a) turn OFF the monitor, (b) replace the sensor, (c) turn monitor ON. It will then recognize that a single sensor has been replaced.

NOTE: Monitor will beep twice when the new sensor(s) is learned.

To replace more than one faulty sensor:

- STEP 1** Press F6 key until the “Mode Selection” screen appears.
- STEP 2** Select “Setup Mode” by turning the knob or press the UP or DOWN arrow keys. Press the knob or ENTER key to display the highlighted item.
- STEP 3** Select “Sensor Setup” by turning the knob or using the UP or DOWN arrow keys. Press the knob or ENTER key to display the highlighted item.

D02140641

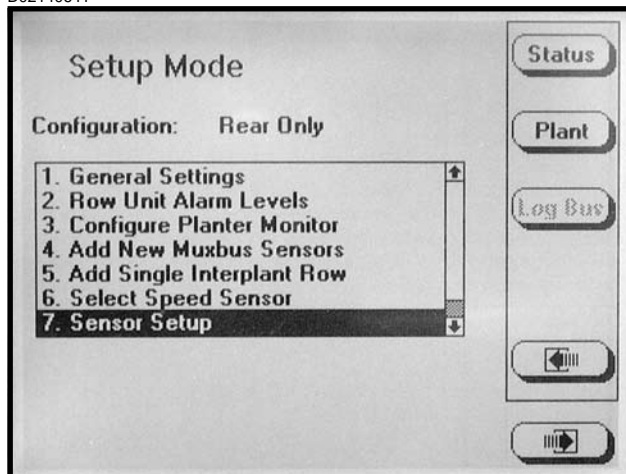

- STEP 4** Highlight faulty sensor. Press REMOVE key and unplug sensor. Plug in new sensor and press INSTALL key.

Repeat above procedure for each faulty sensor being replaced.

D02210601a

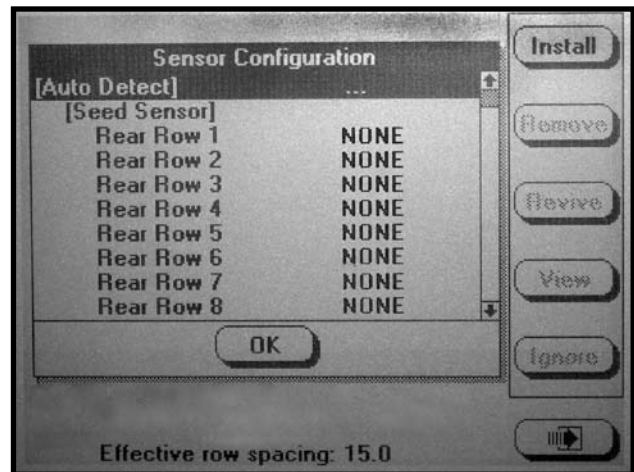

NOTE: Highlighting a sensor and pressing VIEW gives additional information when troubleshooting a problem. If a faulty sensor has been ignored it may be highlighted in the list of sensors, press REVIVE. The monitor will try to communicate with the sensor. If successful, “OK” will appear next to the sensor.

- STEP 5** Press the knob or ENTER key to return to “Setup Mode” screen.
- STEP 6** To return to “Planting Mode” press the PLANT key.

See “KPM III Electronic Seed Monitor Troubleshooting” in the Maintenance Section.

MACHINE OPERATION

POINT ROW CLUTCHES

D032901166

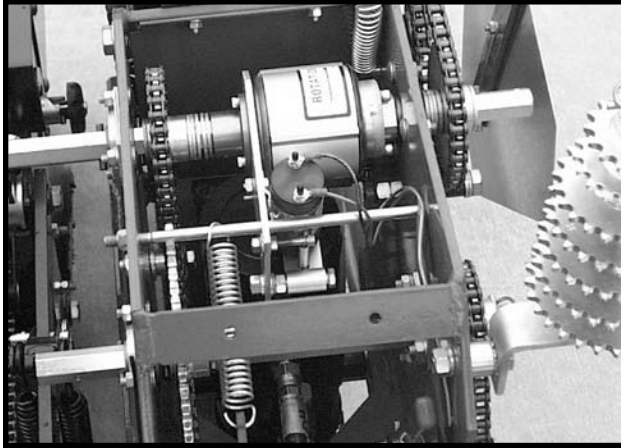

12 Row 30" Machine Shown

With the use of electric-activated clutches, which disengage the drive, either half of the planter may be shut off for finishing up fields or for long point row situations.

76746-24

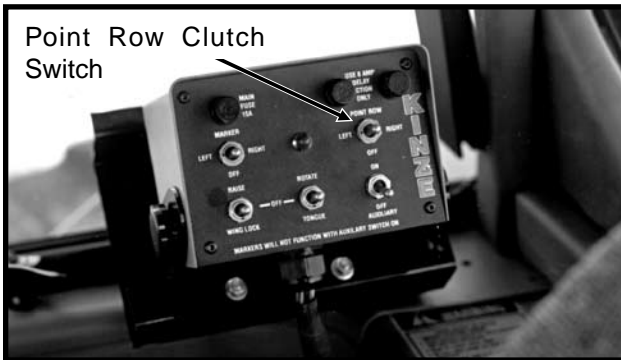

Conventional Planter Control Console

D12160359

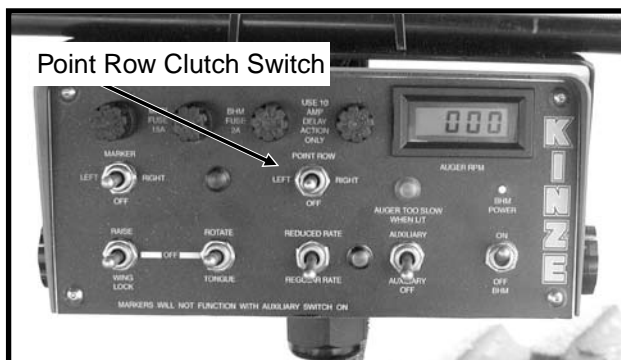

SDS Planter Control Console

The selector switch for the clutches is located on the planter control console.

NOTE: Switch should be left in OFF position when planter is not in use. If left in ON position, the tractor battery will be discharged.

NOTE: Since the liquid fertilizer piston pump has its own drive wheel, liquid fertilizer application will not be affected by use of the point row clutch.

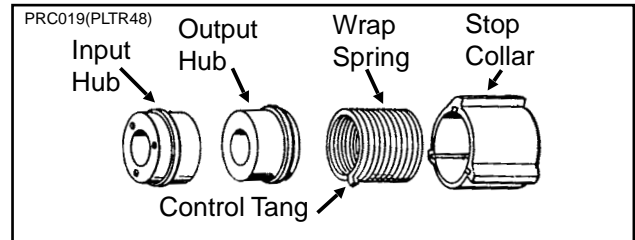

The point row clutch consists of a wrap spring riding on an input hub and an output hub. During operation the wrap spring is wrapped tightly over the hubs connecting them in a positive engagement. The greater the force of rotation the tighter the grip of the spring on the hubs.

Rotation in the opposite direction or stopping the spring from rotating prevents the transmission of torque from the input hub to the output hub, stopping the planter drive.

The input end of the spring is bent outward and is referred to as the control tang. The control tang fits into a slot in the stop collar that is located between the input and output hubs and over the wrap spring. If the stop collar is allowed to rotate with the input hub, the clutch is engaged. If the stop collar is stopped from rotating, the control tang connected to it is forced back and the spring opens. This allows the input hub to continue rotating without transmitting torque to the output hub; therefore, stopping the planter drive.

The stop collar is controlled by the use of an electric solenoid and an actuator arm. When the selector switch on the tractor control console is in the OFF position the solenoid coil is NOT ENERGIZED and the actuator arm will not contact the stop on the stop collar allowing it to rotate with the hubs and drive the planter.

When the operational switch is in the "DISENGAGE" (right or left) position the solenoid coil is ENERGIZED and the plunger in the solenoid coil retracts, allowing the actuator arm to contact the stop on the stop collar, disengaging the wrap spring and stopping the planter drive.

MACHINE OPERATION

TWO-SPEED POINT ROW CLUTCHES

81826-8

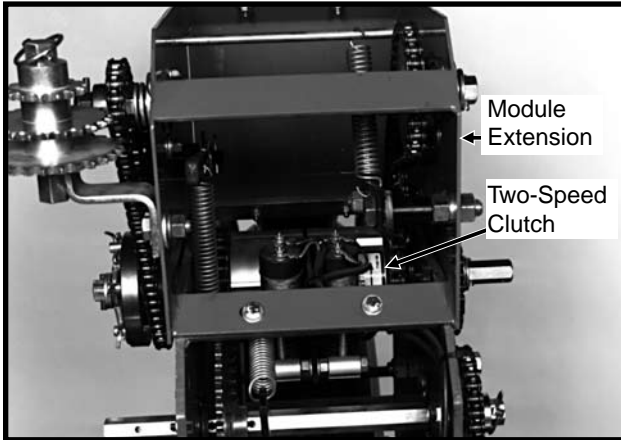

The optional Two-Speed Point Row Clutch Package is designed to allow on-the-go population rate adjustment as well as the capability to shut off either half of the planter for finishing up fields or for long point row situations.

The point row clutches are controlled by the point row clutch switch on the control console. The point row switch is used to shut off either the left or right half of the planter. Activating the reduced rate switch engages one solenoid on each clutch assembly and reduces the planting rate for the entire planter.

NOTE: Point row switch should be left in OFF position and rate switch should be left in FULL RATE position when planter is not in use. If left in ON and/or REDUCED RATE positions, the tractor battery will be discharged.

A7435(TWL81/ELC41)

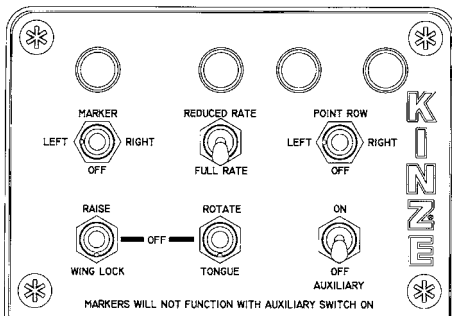

Conventional Planter Control Console

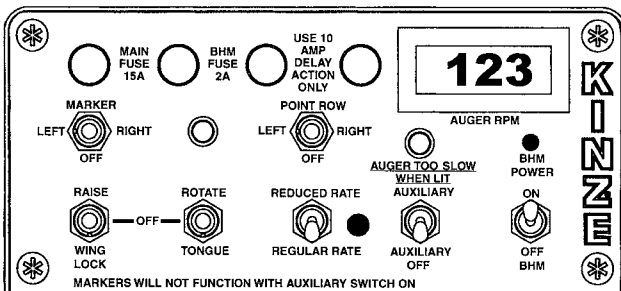

SDS Planter Control Console

The ratio of population reduction is determined by the sprocket ratio between the drive and driven sprockets on the wheel module extension. A rate reduction decal like the one shown below is located on the wheel module extension.

(7100-214)D032901165

TRANSMISSION RATE REDUCTION		
DRIVE	DRIVEN	% REDUCTION IN POPULATION
15	30	50
17	30	43
23*	30	23
24	30	20
25*	30	17
26*	30	13
27	30	10

* Use sprockets off seed drive transmission

7100-214

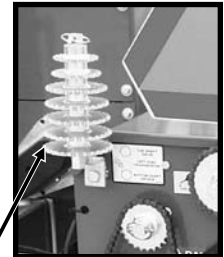

Full rate transmission shown. Two-speed clutch wheel module extension not installed.

(TWL80)

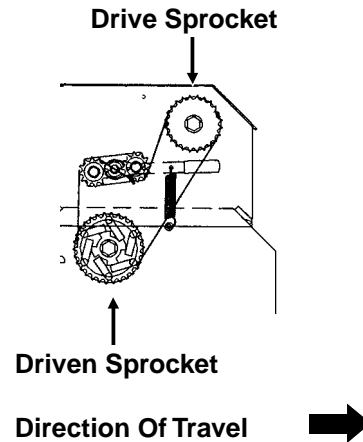

MACHINE OPERATION

AUXILIARY HYDRAULIC OPTION

A customer-supplied auxiliary hydraulic option may be added to provide 10 GPM of oil flow at the rear of the planter. This option may be used for powering fertilizer or seed fill attachments, etc. Two customer-supplied solenoid valve kits (G1K275) are required to activate the auxiliary hydraulic option using the auxiliary switch on the control console.

D032901147

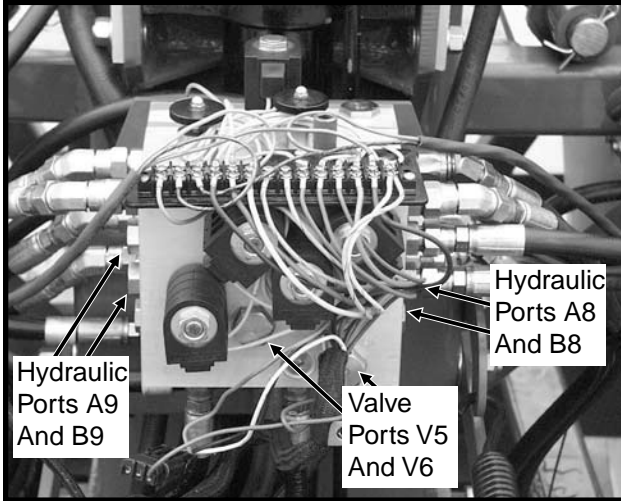

Valve Block Located On Rear Center Frame (Shown With Cover Removed)

76746-24

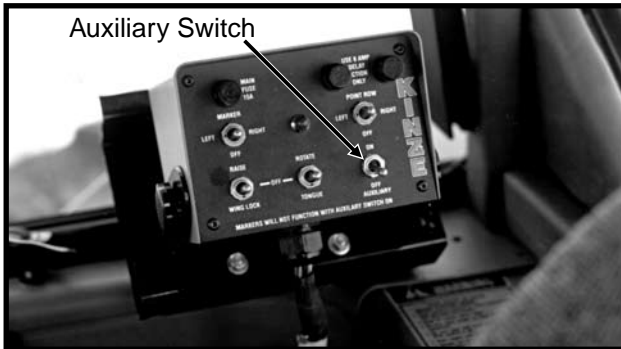

Conventional Planter Control Console

D12160359

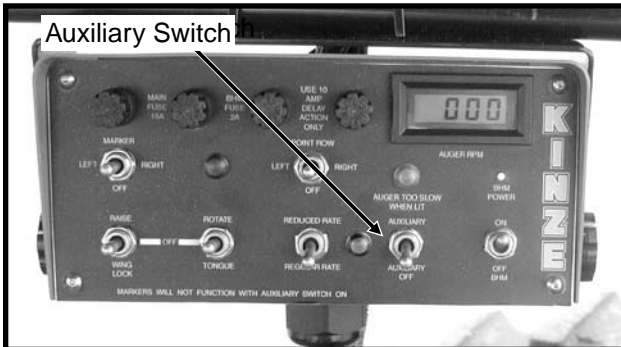

SDS Planter Control Console

NOTE: Be sure markers are in transport position and all pressure is removed from the hydraulic system.

Remove the cover from the valve block, located on the rear center frame of the planter. Remove plugs from ports V5 and V6 and install the solenoid valve assemblies following the installation instruction supplied with each kit. Power to the solenoid assemblies should be connected to the orange/black wires located in the wiring harness connection to the L.H. side of the valve block.

Remove plugs from 3/4"-16 o-ring ports A8 and B8 on R.H. side of valve block or ports A9 and B9 on L.H. side of valve block. Connect customer-supplied hydraulic hoses.

Refer to "Hydraulic System Schematics" and "Electrical Wiring Schematics" in the Maintenance Section of this manual for additional information.



DANGER: Before applying pressure to the hydraulic system, make sure all connections are tight and hoses and fittings have not been damaged. Hydraulic fluid escaping under pressure can have sufficient force to penetrate skin, causing injury or infection.

Before operating the auxiliary system be sure the marker switch on the control console is in the OFF position. Move the auxiliary switch on the control console to ON position. Operate hydraulic control lever (marker/folding functions) to engage auxiliary system.

NOTE: Auxiliary switch left in ON position disables all other control console switches.

MACHINE OPERATION

AUXILIARY WORK LIGHTS PACKAGE

D05160505a



The optional Auxiliary Work Lights Package includes two 50 watt, 3" x 5" halogen flood lamps, hardware to mount lights at the top of one of the lift cylinders and a wiring harness to plug into the existing planter light harness.

EVEN-ROW PUSH ROW UNIT OPTION

The even-row push row unit may be installed on the L.H. end of the forward toolbar to increase planting width.

If markers are set for 30" rows, the R.H. marker extension will need to be moved in 15" when using the even-row push row unit. The L.H. marker extension will need to be moved out 15". See "Row Marker Length Adjustment" for additional information.

To plant two 15" rows between last year's 30" rows and avoid tire damage from stalks by driving off the row, shift the planter off-center as shown in the illustration on the following page.

NOTE: If tractor hitch is offset 7 ½" to the right of the center line of the tractor, add 7 ½" to the marker dimension on the R.H. side of the planter and subtract 7 ½" from the marker dimension on the L. H. side of the planter.

See "Seed Distribution Manifold" in SDS Seed Delivery System Operation for closing off seed flow to the even-row push row unit (If Applicable).

(TWL280)

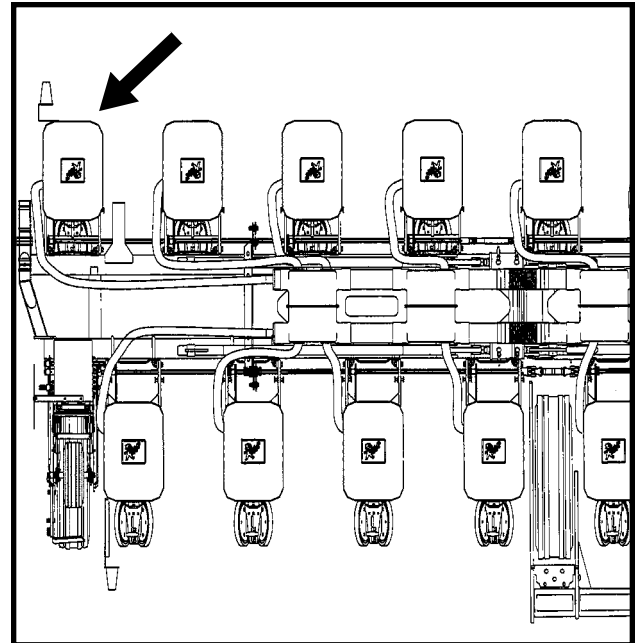

Planter With Conventional Seed Hoppers Shown

MACHINE OPERATION

(TWL280a)

**3650 CONVENTIONAL
12 ROW 30" (24-15") SHOWN**

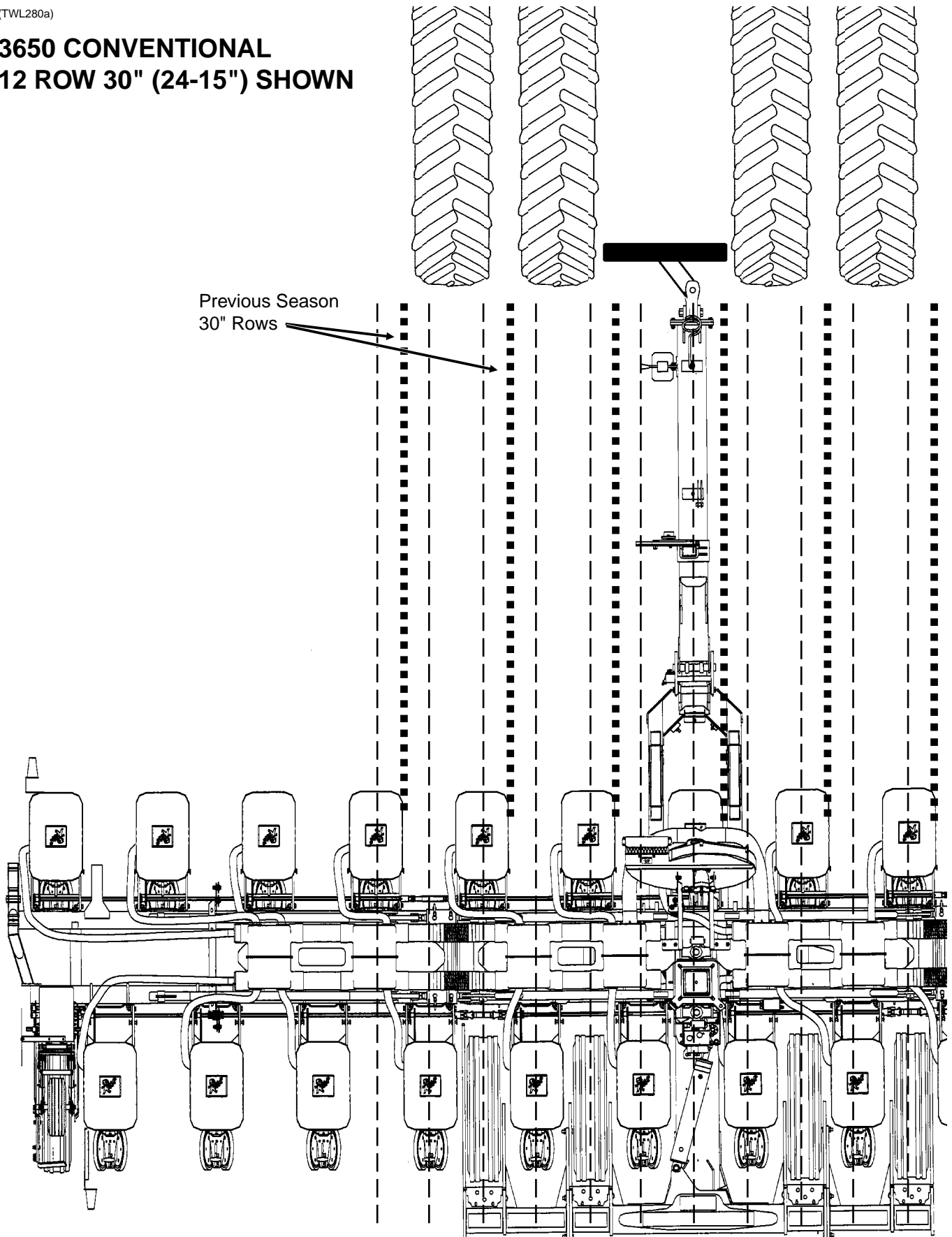

MACHINE OPERATION

DOUBLE DISC FERTILIZER OPENER

The double disc fertilizer openers should be positioned during assembly **to place fertilizer no closer than 2" to either side of the row.** If the planter frame is level and at proper 20" operating height, fertilizer depth will be approximately 4". Soil conditions can affect depth slightly.

The down pressure spring is factory preset at 250 lbs. down pressure but may be adjusted for various soil conditions. To adjust spring tension, loosen the jam nut with a $1\frac{5}{16}$ " wrench and use a 1" wrench to turn the adjustment bolt clockwise to increase tension or counterclockwise to decrease tension. Securely tighten the jam nut upon completion of tension adjustment. Do not attempt to set opener depth with spring pressure. The opener is designed to operate against a depth stop and spring up when encountering a foreign object or hard ground.

IMPORTANT: Do not operate the double disc openers at full down pressure tension when planting in rocky ground. Chipping of the disc blades will occur.

A gap of $\frac{1}{32}$ " to $\frac{1}{16}$ " should be maintained between the opener blades at the closest point. Blade adjustment is made by moving inside spacer washers to the outer side of the blade. After making this adjustment, check to be sure bearing assembly rivets are not contacting the shank.

D06259919

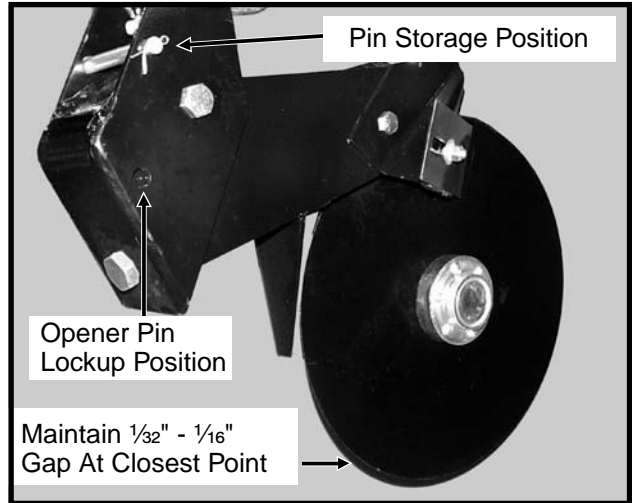

The outer scrapers on each disc blade may also be adjusted to make up for wear that may occur. Make sure the scrapers are adjusted to allow only slight contact with the blades.

The opener assembly is designed to be locked in a raised position when the fertilizer attachment is not in use or during storage. To lock the opener up, first raise the planter and place blocks under the openers. Then lower the planter until the hole in the pivot section aligns with the hole in the mounting bracket. Remove the lockup pin from the storage position in the mounting bracket and install it through the lockup hole and secure with cotter pins.



WARNING: Always install all cylinder lockup devices before working under the unit.

MACHINE OPERATION

NOTCHED SINGLE DISC FERTILIZER OPENER (Style A)

The notched single disc fertilizer opener is designed for use in minimum and no till planting conditions. Placement of fertilizer with the 16 3/4" diameter notched single disc fertilizer opener is recommended at 2 1/2" - 3" from the row. The opener is designed to hold the blade at a set-angle so the knife and drop tube operate in the shadow of the blade. **Never locate the opener to place fertilizer closer than 2".**

⚠ WARNING: Spring under pressure. DO NOT disassemble.

(FRTZ210q/B0297)

Depth Adjustment Cap Screws - Recommended Maximum Operating Depth 4" (Middle Cap Screw Holds Blade Angle But Must Be Loosened To Adjust Depth And Tightened First To Set Blade Angle.)

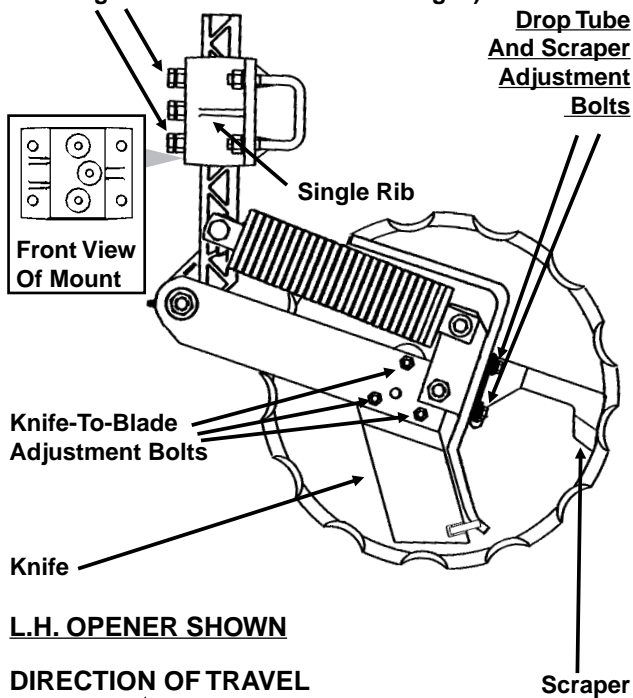

L.H. OPENER SHOWN

DIRECTION OF TRAVEL

Adjust knife-to-blade contact on each fertilizer opener so blade will turn by hand with slight resistance, but will not coast or freewheel. In dry, loose soil the knife adjustment is critical. If adjustment is not maintained, soil or residue may wedge between knife and blade, resulting in the blade not turning. If the knife is adjusted too tight, the blade will not turn causing the blade to push soil and residue. **Knife adjustment is made using the three 3/8" mounting carriage bolts** and pivot pad on the knife. Because of blade runout, rotate blade one full revolution after adjustment. Readjust knife to the blade's tight spot as needed. **Never strike the knife with a heavy object or damage may occur.**

Using the slotted mounting holes in the drop tube mount, **adjust fertilizer drop tube** behind the knife so it is protected from soil contact and wear. The liquid drop tube should be adjusted 1/4" - 3/8" from the opener blade while keeping it behind the knife. Insert a flat bladed pry bar between the knife and drop tube just above the drop tube tab as shown below. Bend the tube inward toward the disc blade to obtain the desired 1/4" - 3/8" adjustment.

D01040702

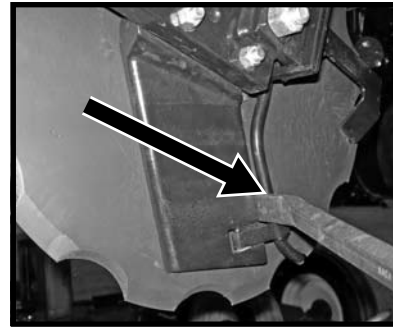

NOTE: Adjusting the liquid drop tube will ensure it is out of the path of the soil flow across the knife. Drop tube and tab will wear quickly if not adjusted correctly.

Adjust scraper to just touch the opener blade. As the mounting hardware is tightened, the scraper is drawn tighter to the blade. After adjustment, rotate opener blade to be sure blade will turn by hand with slight resistance, but will not coast or freewheel.

Adjust blade depth on each row using the cap screws and jam nuts located on the opener mount. The blade can be adjusted to allow a maximum 4" blade depth. Check fertilizer hose clearance (If Applicable) after adjusting opener depth. Torque cap screws and jam nuts to 57 ft. lbs.

NOTE: The blade cuts through the soil at an angle relative to the direction of travel. For this reason and to ensure proper operation, the cast mount should be oriented so the single rib is on the same side of the blade as the drop tube.

FRTZ296

D070103100

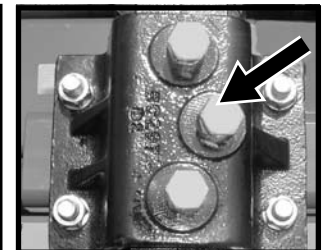
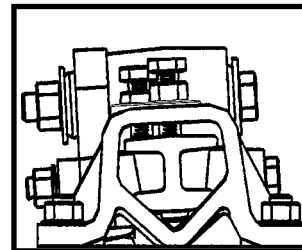

NOTE: Recommended maximum operating depth is 4". To adjust depth: (a) Loosen depth adjustment cap screws. (b) Adjust depth to desired setting. (c) Tighten upper and lower cap screws slightly to hold opener arm in place. (d) Tighten middle cap screw to set the opener arm angle. (e) Tighten upper and lower cap screws and all jam nuts.

MACHINE OPERATION

NOTCHED SINGLE DISC FERTILIZER OPENER (Style B)

The notched single disc fertilizer opener is designed for use in minimum and no till planting conditions. Placement of fertilizer with the 16 3/4" diameter notched single disc fertilizer opener is recommended at 2 1/2" - 3" from the row. The opener is designed to hold the blade at a set-angle so the knife and drop tube operate in the shadow of the blade. **Never locate the opener to place fertilizer closer than 2".**

⚠ WARNING: Spring under pressure. DO NOT disassemble.

(A12429a/B0297)

Depth Adjustment Cap Screws - Recommended Maximum Operating Depth 4" (Middle Cap Screw Holds Blade Angle But Must Be Loosened To Adjust Depth And Tightened First To Set Blade Angle.)

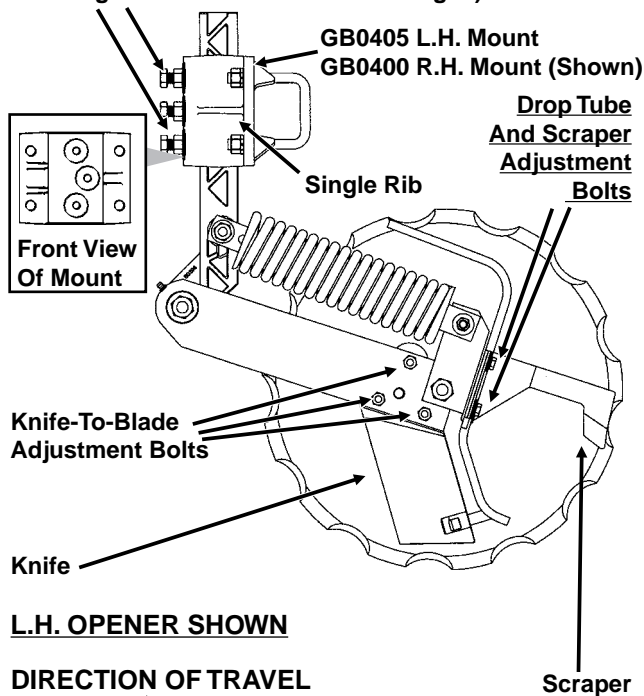

Adjust knife-to-blade contact on each fertilizer opener so blade will turn by hand with slight resistance, but will not coast or freewheel. In dry, loose soil the knife adjustment is critical. If adjustment is not maintained, soil or residue may wedge between knife and blade, resulting in the blade not turning. If the knife is adjusted too tight, the blade will not turn causing the blade to push soil and residue. **Knife adjustment is made using the three 3/8" mounting carriage bolts** and pivot pad on the knife. Because of blade runout, rotate blade one full revolution after adjustment. Readjust knife to the blade's tight spot as needed. **Never strike the knife with a heavy object or damage may occur.**

Using the slotted mounting holes in the drop tube mount, **adjust fertilizer drop tube** behind the knife so it is protected from soil contact and wear. The liquid drop tube should be adjusted 1/4" - 3/8" from the opener blade while keeping it behind the knife. Insert a flat bladed pry bar between the knife and drop tube just above the drop tube tab as shown below. Bend the tube inward toward the disc blade to obtain the desired 1/4" - 3/8" adjustment.

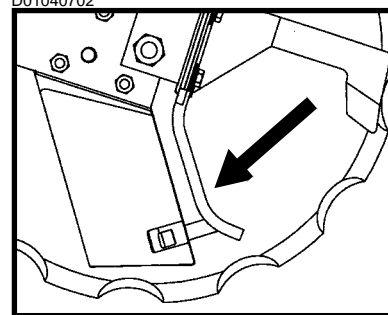

NOTE: Adjusting the liquid drop tube will ensure it is out of the path of the soil flow across the knife. Drop tube and tab will wear quickly if not adjusted correctly.

Adjust scraper to just touch the opener blade. As the mounting hardware is tightened, the scraper is drawn tighter to the blade. After adjustment, rotate opener blade to be sure blade will turn by hand with slight resistance, but will not coast or freewheel.

Adjust blade depth on each row using the cap screws and jam nuts located on the opener mount. The blade can be adjusted to allow a maximum 4" blade depth. Check fertilizer hose clearance (If Applicable) after adjusting opener depth. Torque cap screws and jam nuts to 57 ft. lbs.

D01160802

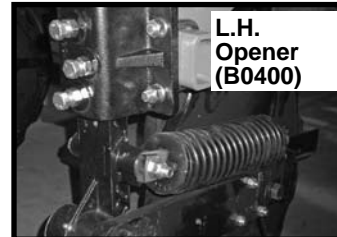

L.H. Opener (B0400)

NOTE: The blade cuts through the soil at an angle relative to the direction of travel. For this reason and to ensure proper operation, the cast mount should be oriented so the single rib is on the same side of the blade as the drop tube.

D01160801

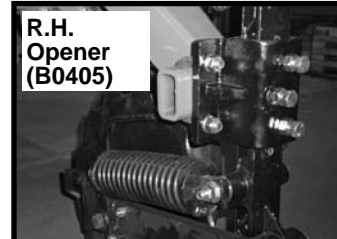

R.H. Opener (B0405)

FRTZ296

D070103100

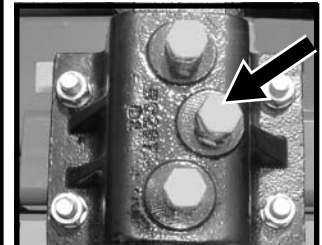
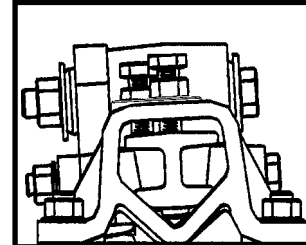

NOTE: Recommended maximum operating depth is 4". To adjust depth: (a) Loosen depth adjustment cap screws. (b) Adjust depth to desired setting. (c) Tighten upper and lower cap screws slightly to hold opener arm in place. (d) Tighten middle cap screw to set the opener arm angle. (e) Tighten upper and lower cap screws and all jam nuts.

MACHINE OPERATION

DEPTH/GAUGE WHEEL ATTACHMENT FOR NOTCHED SINGLE DISC FERTILIZER OPENER

D061101202a

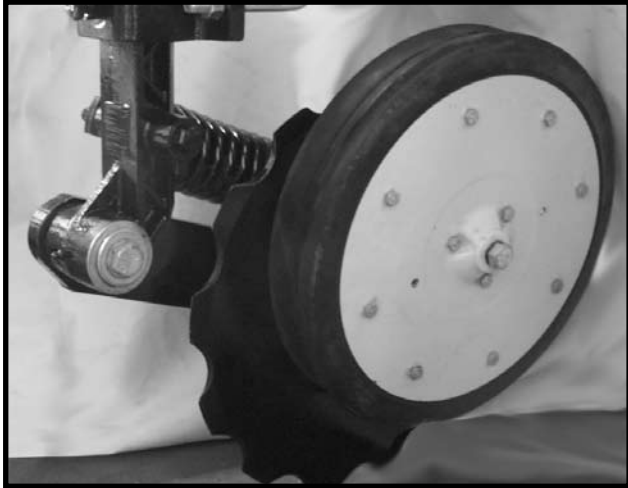

The depth/gauge wheel attachment for the notched single disc fertilizer opener is designed for use in situations where additional gauging is required to maintain desired fertilizer opener depth. The depth/gauge wheel is attached to the notched single disc fertilizer opener using a mounting block fastened to the pivot arm using $\frac{5}{8}$ " hardware through the disc blade hub w/bearing.

Depth adjustment is made by using the 3 adjustment holes in the depth/gauge wheel mounting block. Moving the depth/gauge wheel increases/decreases depth in approximate 1" increments in relation to the blade depth setting made at the vertical mounting post.

D060404201

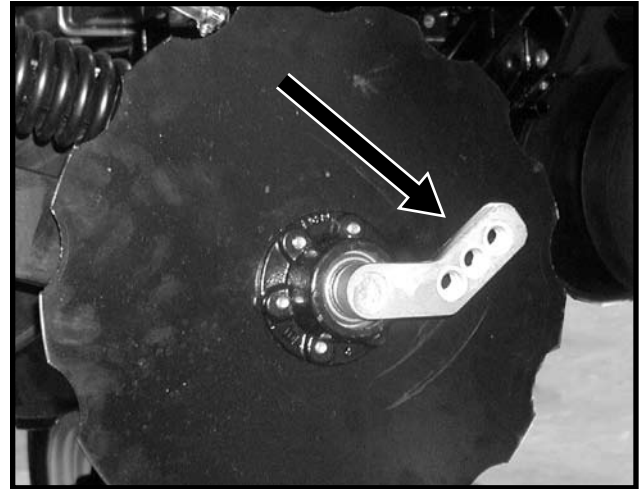

Due to space restrictions, the depth/gauge wheel attachment for the notched single disc fertilizer opener is not applicable to Model 3650 planters equipped with row unit coulter mounted residue wheels.

MACHINE OPERATION

HD SINGLE DISC FERTILIZER OPENER

D062601103

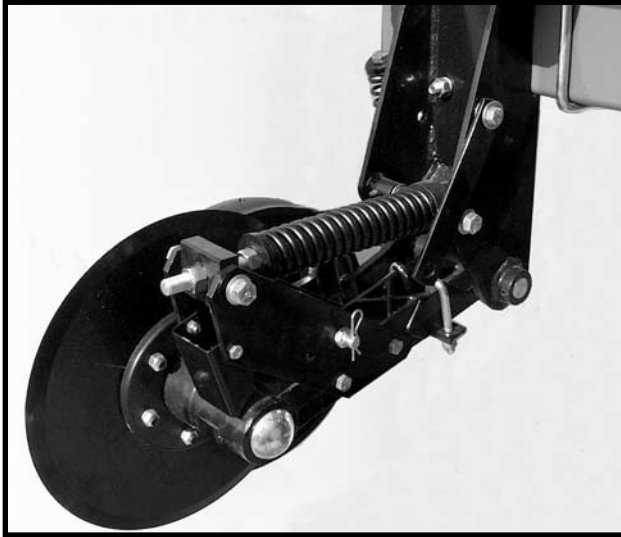

Placement of fertilizer with the HD single disc fertilizer opener is recommended at 3 1/2" - 4" from the row. **Never locate the opener to place fertilizer closer than 2".**

If planter frame is level and at 20" operating height, maximum blade depth for placement of fertilizer is approximately 5". Soil conditions can affect depth slightly.

To adjust blade depth, raise the planter to remove weight from the fertilizer opener. Loosen inside adjustment nut (A) with 1 1/8" wrench. Turn outside nut (B) clockwise to decrease blade depth or counterclockwise to increase blade depth. One full turn of the blade depth adjustment nut changes blade depth 3/8". Tighten inside nut tight against block (C). Adjust all fertilizer openers to the same depth.

L0114(PLTR3)

DIRECTION OF TRAVEL



(Overhead View)

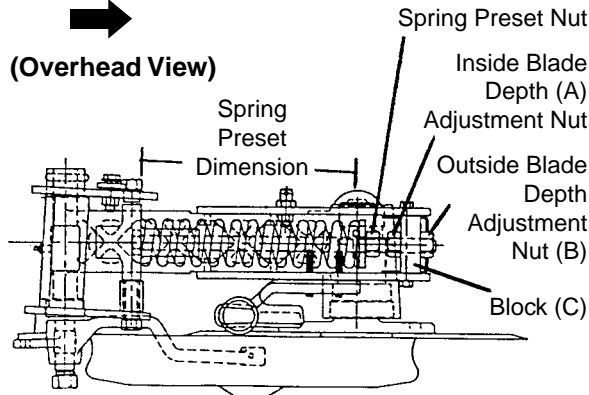

R.H. Configuration Shown

Fertilizer opener down pressure can be adjusted from 250 lbs. to 640 lbs. **To make down pressure adjustments**, raise planter to remove weight from the fertilizer opener and turn spring preset nut clockwise to increase down pressure and counterclockwise to decrease down pressure. Adjust all rows to a similar setting. Minimal spring pressure for acceptable operation is recommended. See chart for spring length setting specifications.

SPRING PRESET DIMENSION	DOWN PRESSURE (LBS.)
11"	250
10 3/4"	320
*10 1/2"	370
10 1/4"	450
10"	520
9 3/4"	580
9 1/2"	640

* Suggested initial setting.

NOTE: DO NOT adjust spring preset dimension to less than 9 1/2".

NOTE: Excessive down pressure can cause up-lift on the planter frame and affect performance of the machine. When lowered to planting position, planter frame should be at a height of approximately 20". In loose soil conditions, excessive down pressure can cause openers to run too deep and push dirt ahead of opener and may stop soil press wheel and/or opener blade from turning.



WARNING: Always install all safety lockup devices before working under the machine.

IMPORTANT: Do not operate HD single disc openers at full down pressure tension when planting in rocky ground. Chipping or breakage of the blades will occur.

MACHINE OPERATION

Maintain liquid fertilizer drop tube/scraper adjustment as shown below.

(INS16a)

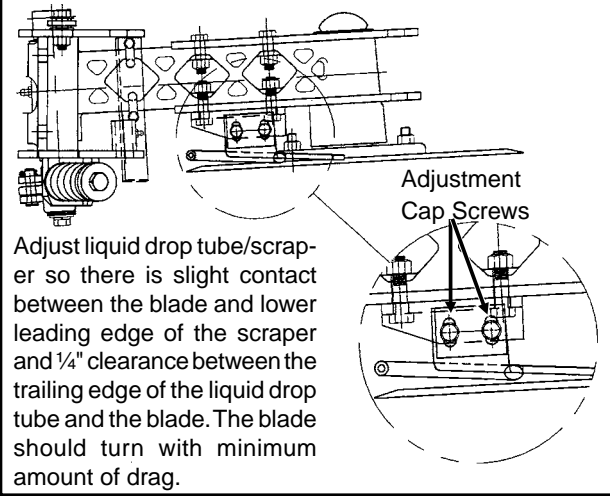

Additional press wheel down pressure may be desirable in heavy moist soils. **To increase press wheel spring pressure** turn press wheel spring adjustment bolt clockwise.

D121202101

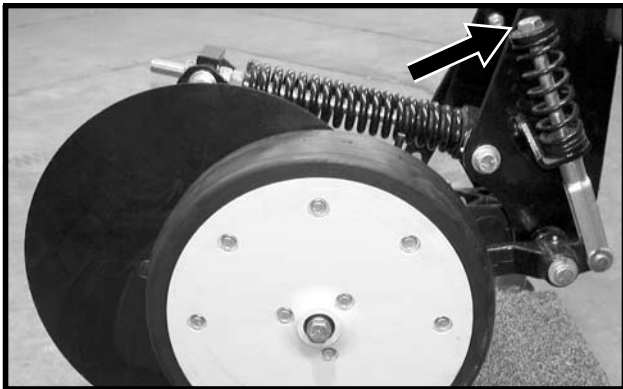

NOTE: The soil press wheel is not intended to be used for gauging fertilizer opener operating depth.

The HD single disc fertilizer opener is designed to be locked in a raised position when the fertilizer attachment is not in use or during storage.

To lock the HD single disc fertilizer opener in the raised position, proceed as follows:

STEP 1 With the planter in the planting position, remove outside blade depth adjustment nut. ("B" in illustration on previous page.)

STEP 2 Raise planter until adjustment bolt clears adjustment block.

STEP 3 Raise spring to clear blade assembly and at the same time raise blade assembly until storage strap can be positioned onto lockup pin and install hair pin clip.

STEP 4 Reinstall depth adjustment nut and tighten.

D062601102

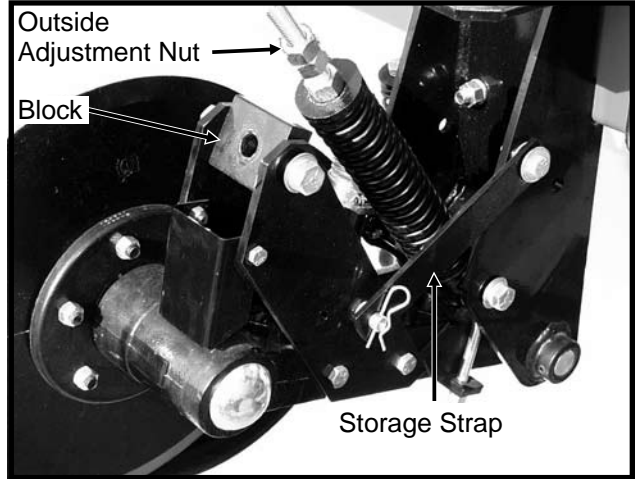

NOTE: The HD single disc fertilizer opener is equipped with a lockup bar that automatically raises and locks the soil press wheel when the blade assembly is raised.

FOC016(PLTR5b)

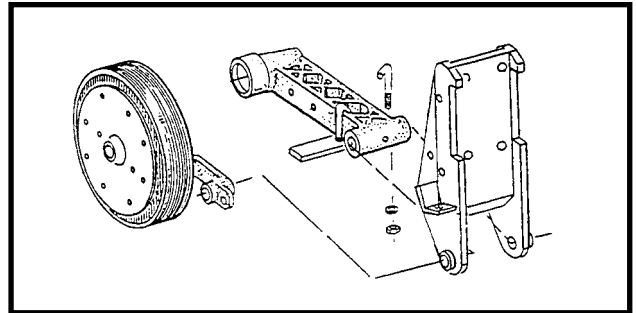

MACHINE OPERATION

LIQUID FERTILIZER ATTACHMENT

D11070360



Model 3650 SDS 16 Row 30" Planter

NOTE: An optional low rate check valve is available for installation in-line between the liquid fertilizer piston pump and the liquid fertilizer openers to ensure equal distribution of product at low rates. The check valve will eliminate the need for anti-siphon loops if the valves are installed as close as possible to the fertilizer opener drop tubes.

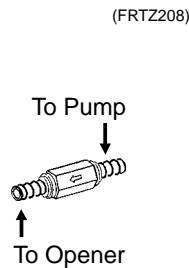

PISTON PUMP

If the machine is equipped with the piston pump option, the rate of liquid fertilizer application is determined by the piston pump settings.

The delivery rate chart found at the end of this section provides an approximate application rate only. Actual delivery will vary with temperature and the particular fertilizer being used.

To adjust delivery rate, loosen the $\frac{3}{8}$ " lock nut that secures the arm with the pointer and rotate the scale flange until the pointer is over the desired scale setting. The adjustment wrench will facilitate rotation of the scale flange. Tighten the $\frac{3}{8}$ " lock nut being careful not to over tighten.

(PLTR9/12330b)

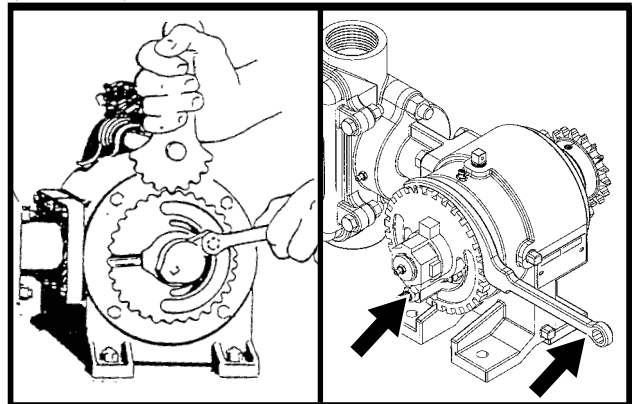

The operator and instruction manual shipped with the pump and flow divider should be kept and stored with this manual for future reference.

NOTE: Periodically check flow to all rows. If one or more lines are plugged, set rate will be delivered to remaining rows.

MACHINE OPERATION

PISTON PUMP GROUND DRIVE WHEEL SPRING ADJUSTMENT

Initial spring tension of the down pressure spring on the piston pump ground drive wheel is set leaving $12\frac{1}{4}$ " between the bottom of the mounting plate and the plug on top of the spring. This dimension is taken with the planter in raised position (tire not contacting the ground). Further adjustment can be made to fit conditions.

(TWL219tt)

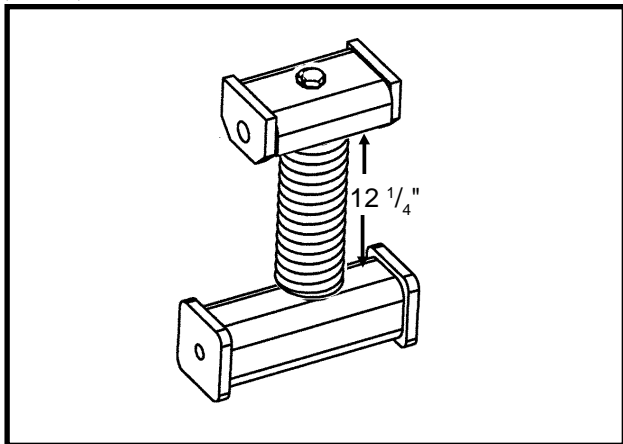

NOTE: The piston pump ground drive wheel assembly is designed to allow the assembly to be locked in raised position when not in use. Remove the two cap screws that attach the upper end of the spring to the spring mount. Reattach the spring using the upper holes in the spring mount. Reverse procedure to reset for field use.

CLEANING

The tanks and all hoses are made of sturdy plastic and rubber to resist corrosion. However, the tanks, hoses and metering pump should be thoroughly cleaned with water at the end of the planting season or prior to an extended period of non-use. Do not allow fertilizer to crystalize due to cold temperature or evaporation.

The strainer, located between the piston pump and ball valve (On machines equipped with the piston pump.), should be taken apart and cleaned daily. Remove the end cap to clean the screen.

(INS220)

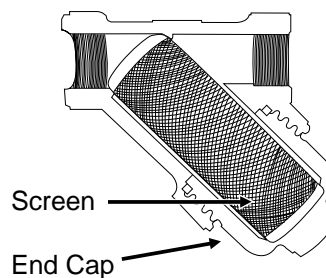

See "Piston Pump Storage" (If Applicable) in the Maintenance section of this manual.

MACHINE OPERATION

LIQUID FERTILIZER PISTON PUMP APPLICATION RATES GALLONS PER ACRE

Applies To Model LM-4405 And NGP-7055 Pumps With 18 Tooth Sprocket

Pump Setting	1	2	3	4	5	6	7	8	9	10
12 Row 30"	3.7	7.4	11.1	14.8	18.5	22.1	25.8	29.5	33.2	36.9
16 Row 30"	2.8	5.5	8.3	11.1	13.9	16.6	19.4	22.2	24.9	27.7

Above chart is for planters equipped with 7.60" x 15" drive wheel, based on 91" forward travel per wheel revolution, 48 tooth drive sprocket and 18 tooth driven sprocket on metering pump. Chart is based on average wheel slippage and liquid viscosities.

Measure and weigh one gallon of actual fertilizer solution to determine exact application rate. This chart was calculated based on a solution weighing ten pounds per gallon.

NOTE: Fertilizer application rates can vary from the above chart. To prevent application miscalculations, make field checks to be sure you are applying fertilizer to all rows at the desired rate.

NOTE: Flow to all rows should be checked periodically. If one or more lines are plugged, the desired rate will be delivered to the remaining rows keeping total application rate at desired rate.

To check the exact number of gallons your fertilizer attachment will actually deliver on a 30" row spacing, proceed as follows:

Remove the hose from one of the fertilizer openers and insert it into a collection container which has been secured to the planter frame. Engage the fertilizer attachment and drive forward for 174'. Measure the fluid ounces caught in the container and multiply that amount by 100. Divide that amount by 128. The result will be the gallons of fertilizer delivered per acre when planting in 30" rows. Rinse the collection container and repeat test on other rows if necessary.

MACHINE OPERATION

REAR TRAILER HITCH

The Rear Trailer Hitch is used to tow a 3 or 4 wheel wagon behind the planter. Any hoses routed to the rear trailer hitch should follow hydraulic hose routings on the planter to allow the planter to be raised and rotated to and from the transport position without stretching the hoses.

IMPORTANT: Maximum allowable hitch weight is 200 lbs. Gross towing weight should not exceed 6000 lbs. or the equivalent of a loaded 500 gallon tank and running gear.

NOTE: Periodically check feed hose for kinks to prevent restricted delivery rate.

(TWL280b)

3650 CONVENTIONAL 12 ROW 30" SHOWN

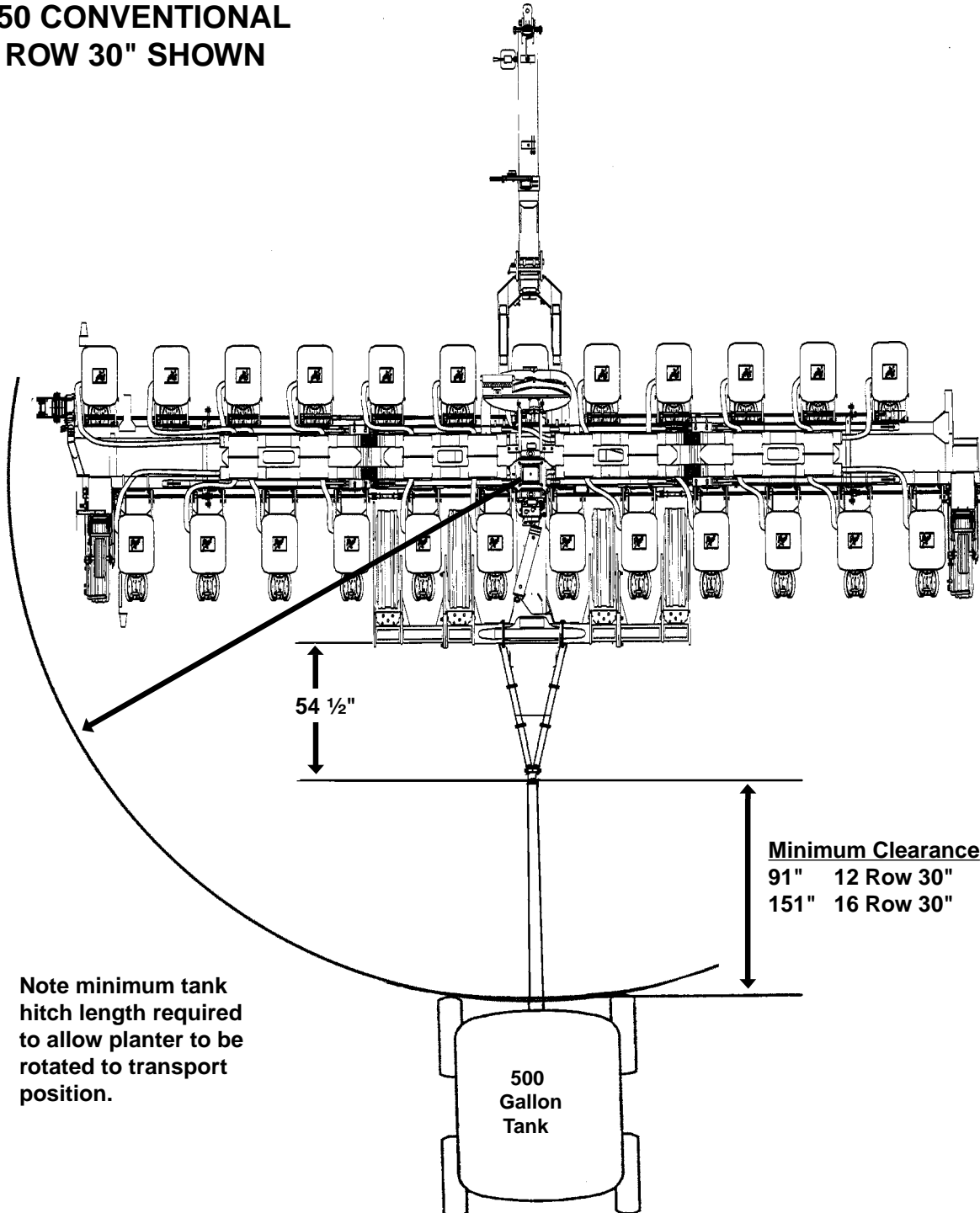

MACHINE OPERATION

TRANSPORTING THE PLANTER



WARNING: Always make sure safety/warning lights, reflective decals and SMV sign are in place and visible prior to transporting the machine on public roads. In this regard, check federal, state/provincial and local regulations.

IMPORTANT: Avoid transporting planter with bulk seed hoppers loaded whenever possible. When it is necessary to transport the planter with the bulk seed hoppers loaded, the added weight should be distributed evenly on the planter frame before rotating the planter.



WARNING: Install all safety lockup devices and safety lock pins before transporting the planter.

METRIC CONVERSION TABLE

MULTIPLY	BY	TO GET
Inches (in.)	x 2.54	= centimeters (cm)
Inches (in.)	x 25.4	= millimeters (mm)
Feet (ft.)	x 30.48	= centimeters (cm)
Acres	x 0.405	= hectares (ha)
Miles per hour (mph)	x 1.609	= kilometers per hour (Km/h)
Pounds (lbs.)	x 0.453	= kilograms (kg)
Bushels (bu.)	x 35.238	= liters (l)
Gallons (gal.)	x 3.785	= liters (l)
Pounds per square inch (psi)	x 6.894	= kilopascals (kPa) (100 kPa = 1 bar)
Inch pounds (in. lbs.)	x 0.113	= newtons-meters (N•m)
Foot pounds (ft. lbs.)	x 1.356	= newtons-meters (N•m)
Centimeters (cm)	x .394	= inches (in.)
Millimeters (mm)	x .0394	= inches (in.)
Centimeters (cm)	x .0328	= feet (ft.)
Hectares (ha)	x 2.469	= acres
Kilometers per hour (Km/h)	x 0.621	= miles per hour (mph)
Kilograms (kg)	x 2.208	= pounds (lbs.)
Liters (l)	x 0.028	= bushels (bu.)
Liters (l)	x 0.264	= gallons (gal.)
Kilopascals (kPa) (100 kPa = 1 bar)	x 0.145	= pounds per square inch (psi)
Newtons-meters (N•m)	x 8.85	= inch pounds (in. lbs.)
Newtons-meters (N•m)	x 0.738	= foot pounds (ft. lbs.)

PLANTING SPEED

Planters are designed to operate within a speed range of 2 to 8 MPH. Generally, higher ground speeds will cause more variation in seed spacing. Speeds above 5.5 MPH are typically not recommended. See “Planting And Application Rate Charts” in Seed Meter Operation/Maintenance section for specific recommendations.

FIELD TEST

With any change of field and/or planting conditions, seed size or planter adjustment, we recommend a field test be made to ensure proper seed placement and operation of row units. See “Planting And Application Rate Charts” in the Seed Meter Operation/Maintenance section and “Checking Seed Population” and “Checking Granular Chemical Application Rate” at end of this section.

- Check the planter for fore to aft and lateral level operation. See “Leveling The Planter” and “Leveling The Planter Wings”.
- Check **all** row units to be certain they are running level. When planting, the row unit parallel arms should be approximately parallel to the ground.
- Check row markers for proper operation and adjustment. See “Row Marker Length Adjustment”, “Row Marker Speed Adjustment” and “Row Marker Operation”.
- Check for proper application rates and placement of granular chemicals on **all** rows. See “Checking Granular Chemical Application Rate”.
- Check for desired depth placement and seed population on **all** rows. See “Checking Seed Population”.
- Check for proper application rates of fertilizer on **all** rows. See “Fertilizer Application Rate Chart”.

After the planter has been field tested, reinspect the machine.

- Hoses And Fittings
- Bolts And Nuts
- Cotter Pins And Spring Pins
- Drive Chain Alignment

MACHINE OPERATION

CHECKING SEED POPULATION

1. Tie up one or more sets of closing wheels by running a light chain or rubber tarp strap between the hopper support panel and closing wheels. It may be necessary to decrease closing wheel arm spring tension.

(RU113g)

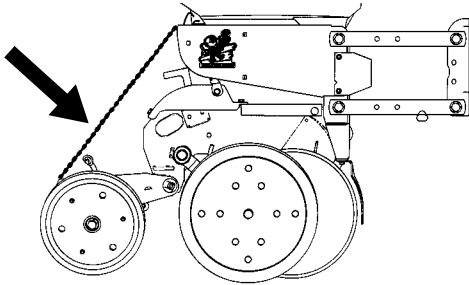

2. Plant a short distance and check to see if seed is visible in the seed trench. Adjust planting depth to a shallower setting if seed is not visible and recheck.

D020705102

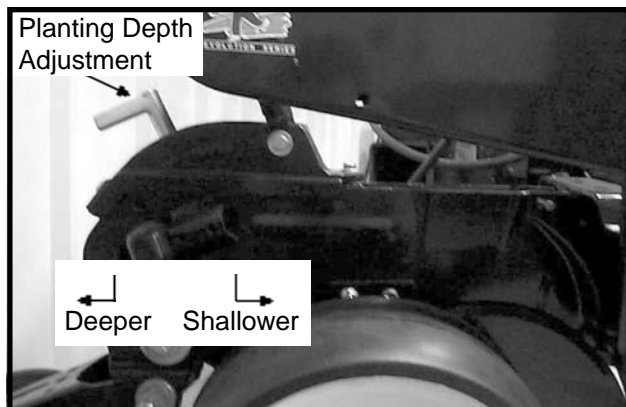

3. Measure $\frac{1}{1000}$ of an acre. See chart for correct distance for row width being planted. For example, if planting 30" rows $\frac{1}{1000}$ of an acre would be 17' 5".

LENGTH OF ROW IN FEET AND INCHES		
Fraction Of Acre	Row Width	
	15"	30"
$\frac{1}{1000}$	34' 10"	17' 5"

NOTE: When planting with closing wheels raised and planting depth set shallow, seeds may bounce or roll affecting seed spacing accuracy.

- Count seeds in measured distance.
- Multiply the number of seeds placed in $\frac{1}{1000}$ of an acre by 1000. This will give you total population.

EXAMPLE: With 30" row spacing 17' 5" equals $\frac{1}{1000}$ acre.

26 Seeds Counted	x	1000	=	26,000 Seeds Per Acre
---------------------	---	------	---	-----------------------

Seed count can be affected by drive ratio between drive wheel and seed meter, tire pressure and/or seed meter malfunction.

If seed check shows the average distance between seeds in inches is significantly different than the seed rate chart indicates, first check drive ratio between drive wheel and seed meter. Check drive wheel air pressure, check for incorrect sprocket(s) in driveline and check drive and driven sprockets in transmission for proper selection.

Second, check for seed meter performance. For example, if spacing between kernels of corn at the transmission setting being used is 8" and a gap of 16" is observed, a seed cell has lost its seed. If two seeds are found within a short distance of each other, the seed cell has metered two seeds instead of one.

See "Seed Metering System Troubleshooting" in the Seed Meter Operation/Maintenance section of this manual.

Determining Pounds Per Acre

To determine pounds per acre:

Seeds Per Acre On Chart	÷	Seeds Per Pound From Seed Tag On Bag	=	Pounds Per Acre
-------------------------------	---	---	---	-----------------------

To determine bushels per acre:

Pounds Per Acre	÷	Unit Weight Of Seed	=	Bushels Per Acre
--------------------	---	------------------------	---	---------------------

The unit weight of:

- 1 Bushel Soybeans = 60 Pounds
- 1 Bushel Milo/Grain Sorghum = 56 Pounds
- 1 Bushel Cotton = 32 Pounds

If seeds per pound information is not available the following is an average:

- 2,600 seeds per pound for medium size soybeans
- 15,000 seeds per pound for medium size milo/
grain sorghum
- 4,500 seeds per pound for medium size cotton

If seed population check shows planting rate is significantly different than seed rate chart shows or if a particular meter is not planting accurately, see "Seed Metering System Troubleshooting" in the Seed Meter Operation/Maintenance section of this manual.

MACHINE OPERATION

CHECKING GRANULAR CHEMICAL APPLICATION RATE

Many things can affect the rate of delivery of granular chemicals such as temperature, humidity, speed, ground conditions, flowability of different material or any obstruction in the meter.



WARNING: Agricultural chemicals can be dangerous if not selected and handled with care. Always read and follow directions supplied by the chemical manufacturer.

A field check is important to determine correct application rates.

D05149901



To check, fill insecticide and/or herbicide hoppers. Attach a calibrated vial to each granular chemical meter. Lower the planter and proceed as follows.

NOTE: It is not necessary for seed meter clutch to be engaged during test. Disengage clutch to avoid dropping seed.

Drive 1320 feet at planting speed. Weigh the chemical in ounces that was caught in one vial. Multiply that amount by the factor shown to determine pounds per acre.

POUNDS PER ACRE FACTOR FOR GIVEN ROW WIDTH	
Row Width	Factor
30"	0.83

EXAMPLE: You are planting 30" rows. You have planted for 1320 feet at the desired planting speed. You caught 12.0 ounces of chemical in one vial. 12.0 ounces times 0.83 equals 9.96 pounds per acre.

NOTE: It is important to check calibration of all rows.

Metering Gate

Use the metering gate setting for distributing insecticide or herbicide as a starting point. The charts are based on a 5 miles per hour planting speed. For speeds faster than 5 miles per hour a higher gate setting should be used. For speeds slower than 5 miles per hour a lower gate setting should be used.

SEED METER OPERATION/MAINTENANCE

GENERAL PLANTING RATE INFORMATION

These planting rate charts are applicable to KINZE® Model 3650 EdgeVac® Twin-Line® Planters. See "Tire Pressure" for recommended tire pressures.

IMPORTANT: The sprocket combinations listed in these charts are best for average conditions. Changes in sprocket combinations may be required to obtain desired planting population. **TO PREVENT PLANTING MISCALCULATIONS, MAKE FIELD CHECKS TO BE SURE YOU ARE PLANTING AT THE DESIRED RATE.**

The size and shape of seed may affect the planting rate.

The following seed discs are available for use with the KINZE® EdgeVac® Seed Metering System:

Corn/Popcorn: 39 cell. Light blue color-coded. For all seed corn grades from 35 to 70 pounds per 80,000 kernel count unit or popcorn seed size range from 2210 to 4200 seeds per pound. *When planting popcorn this seed disc requires use of seed baffle. See "Seed Meter" on pages 7-2 and 7-3 for additional information.*

Low-Rate Corn/Popcorn: 24 cell. Light green color-coded. For all seed corn grades from 35 to 70 pounds per 80,000 kernel count unit or popcorn seed size range from 2210 to 4200 seeds per pound. *When planting popcorn this seed disc requires use of seed baffle. See "Seed Meter" on pages 7-2 and 7-3 for additional information.*

Soybean: 60 cell. Black color-coded. Seed size range from 2200 to 4000 seeds per pound. *This seed disc requires use of seed baffle. See "Seed Meter" on pages 7-2 and 7-3 for additional information.*

Soybean, High-Rate: 120 cell. Dark blue color-coded. Seed size range from 2200 to 4000 seeds per pound. *This seed disc requires use of seed baffle. See "Seed Meter" on pages 7-2 and 7-3 for additional information.*

Milo/Grain Sorghum: 60 cell. Yellow color-coded. Seed size range from 10,000 to 20,000 seeds per pound. *This seed disc requires use of seed baffle and cleanout brush. See "Seed Meter" on pages 7-2 and 7-3 for additional information.*

Hill-Drop Cotton, Acid-Delinted (3 Seeds Per Cell): 20 cell. Brown color-coded. Cotton seed size range from 3800 to 4400 seeds per pound. *This seed disc requires use of cleanout brush w/ball-type ejector. See "Seed Meter" on pages 7-2 and 7-3 for additional information.*

Cotton, Acid-Delinted/Small Dry Edible Bean: 54 cell. Dark green color-coded. Cotton seed size range from 3800 to 4400 seeds per pound or dry edible bean seed size range from 1200 to 2500 seeds per pound. *This seed disc requires use of cleanout brush w/ball-type ejector. See "Seed Meter" on pages 7-2 and 7-3 for additional information.*

Large Dry Edible Bean: 54 cell. Tan color-coded. Seed size range from 800 to 1200 seeds per pound.

NOTE: Due to a multitude of variables, seed spacing can be adversely affected at speeds above 5.5 MPH.

NOTE: See "Seed Meter Singulator Brush And Vacuum Level Adjustments" on page 7-26.

NOTE: 22, 28 and 44 tooth drive sprockets are NOT applicable to all rate charts. Check chart titles to ensure proper rate chart is selected.

22 tooth sprockets require use of 114 pitch No. 40 chains.
28 tooth sprockets require use of 118 pitch chains.
44 tooth sprockets require use of 126 pitch chains.

D070699113a



NOTE: Contact wheel drive sprocket referenced at top of each rate chart.

SEED METER OPERATION/MAINTENANCE

SEED METER

(METR71/METR71a)

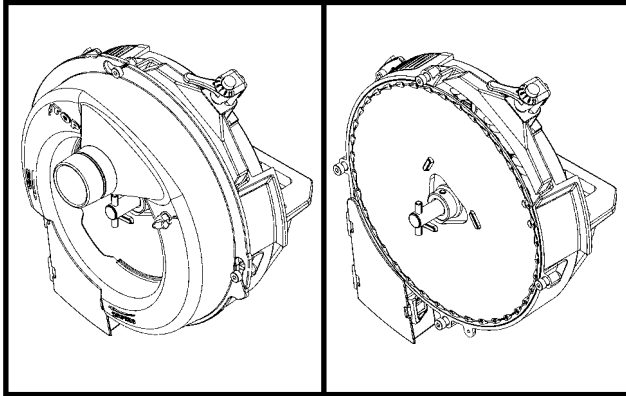

(METR70/D14467a)

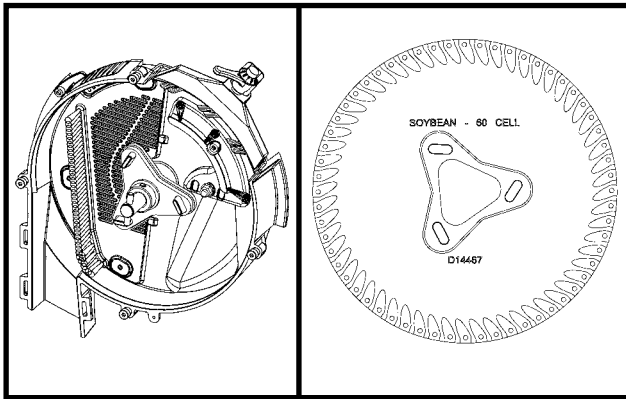

The seed discs below and at right are available for use with the KINZE® EdgeVac® Seed Metering System:

Corn/Popcorn: 39 cell. For all seed corn grades from 35 to 70 pounds per 80,000 kernel count unit. Popcorn seed size range from 2210 to 4200 seeds per pound (*Light blue color-coded.*)

(D14465)

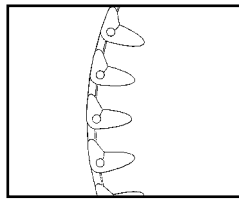

Low-Rate Corn/Popcorn: 24 cell. For all seed corn grades from 35 to 70 pounds per 80,000 kernel count unit. Popcorn seed size range from 2210 to 4200 seeds per pound. (*Light green color-coded.*)

(D16734a)

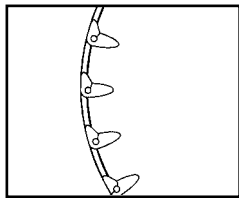

Soybean: 60 cell. Seed size range from 2200 to 4000 seeds per pound. (*Black color-coded.*)

(D14467a)

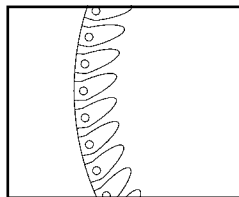

Soybean, High-Rate: 120 cell. Seed size range from 2200 to 4000 seeds per pound. (*Dark blue color-coded.*)

(D14468a)

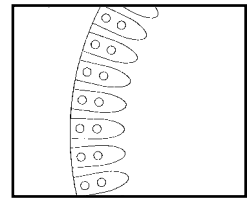

Milo/Grain Sorghum: 60 cell. Seed size range from 10,000 to 20,000 seeds per pound. (*Yellow color-coded.*)

(D17050)

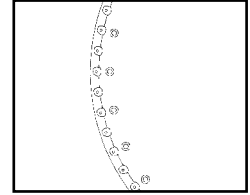

Hill-Drop Cotton, Acid-Delinted (3 Seeds Per Cell): 20 cell. Cotton seed size range from 3800 to 5200 seeds per pound. (*Brown color-coded.*)

(D17187)

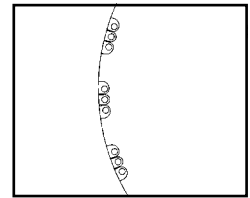

Cotton, Acid-Delinted/Small Dry Edible Bean: 54 cell. Cotton seed size range from 3800 to 5200 seeds per pound. Dry edible bean seed size range from 1200 to 2500 seeds per pound. (*Dark green color-coded.*)

(D17186)

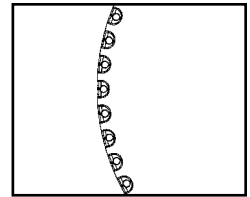

Large Dry Edible Bean: 54 cell. Seed size range from 800 to 1200 seeds per pound. (*Tan color-coded.*)

(D14477)

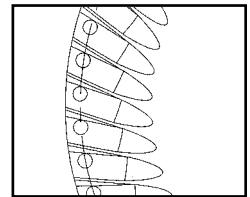

Install the selected seed disc. Position the vacuum cover on the meter by aligning the keyhole slots over the bolt heads. Push the cover on the meter and turn counter clockwise to lock in place. **See following page for additional components required with specific seed discs.**

SEED METER OPERATION/MAINTENANCE

SEED BAFFLE

- Milo/Grain Sorghum
- Soybeans
- Popcorn

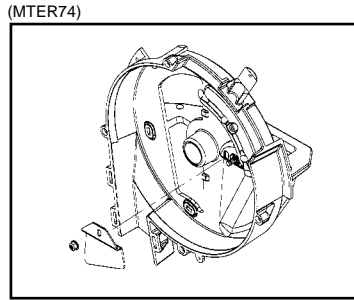

The **seed baffle** is designed to prevent excessive seed in the meter from restricting air flow through the seed. **Used with 60 Cell Milo/Grain Sorghum Disc, 60 Cell Soybean Disc, 120 Cell High-Rate Soybean Disc and 39 Cell and 24 Cell Popcorn Discs.**

CLEANOUT BRUSH

- Milo/Grain Sorghum

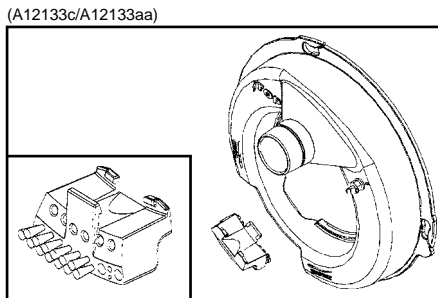

The **cleanout brush** is designed to remove foreign material and seed remnants to help prevent plugging of seed disc orifices.

Used with 60 Cell Milo/Grain Sorghum Disc.

CLEANOUT BRUSH W/BALL-TYPE EJECTOR

- Cotton
- Small Edible Beans

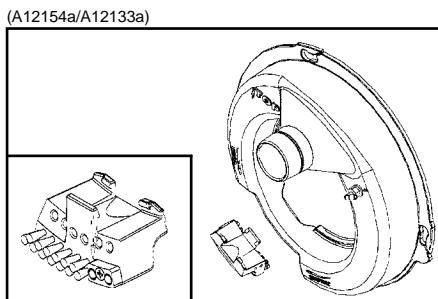

The **cleanout brush w/ball-type ejector** is designed to eject seed remnants from the seed disc orifices.

Used with 20 Cell Hill-Drop Cotton, Acid-Delinted (3 Seeds Per Cell) Discs And 54 Cell Acid-Delinted Cotton/Small Dry Edible Bean Disc.

(METR70)

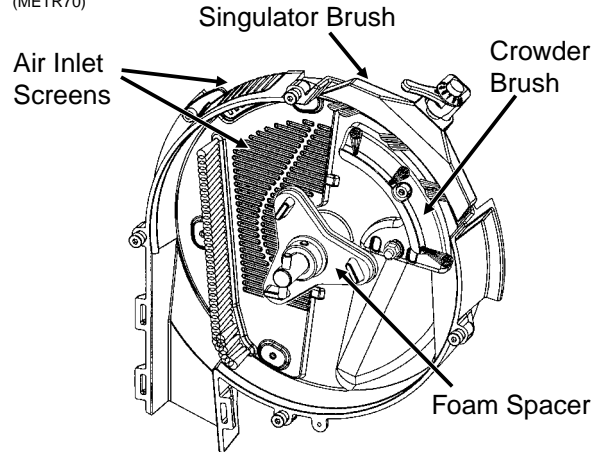

The crowder brush aids in the singulation of small flat seeds by (a) crowding seeds to the outer perimeter of the seed disc and (b) orienting seeds to allow the singulator brush to be more effective.

The air inlet screens allow air to enter the system and aids in keeping field residue or other foreign material out of the meter.

The foam spacer gently preloads the seed disc against the vacuum cover when no vacuum is present.

(METR71)

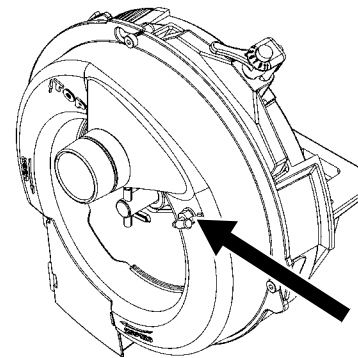

The $\frac{3}{16}$ " hose barb elbow on the seed meter vacuum cover allows measurement of vacuum level at each meter. A customer-supplied vacuum gauge is required.

See "Seed Meter Singulator Brush And Vacuum Level Adjustments", "Seed Meter Maintenance" and "Preparation For Storage" for additional EdgeVac® Seed Metering System information.

SEED METER OPERATION/MAINTENANCE

CONVENTIONAL SEED HOPPERS

One tablespoon of **powdered graphite** should be mixed with the seed each time the hoppers are filled. Regular graphite use will prolong the life of the brush-type seed meter components, improve seed spacing, and may reduce buildup of seed treatments. Apply graphite around the outer perimeter of the hopper as shown below.

D05300104b



NOTE: DO NOT apply graphite only in the center of the hopper. It will filter too quickly through the seed and not distribute as evenly as desired.

NOTE: Additional graphite or talc may be required to retard buildup of seed treatments on meter components. More frequent cleaning of monitor seed tubes may be necessary due to use of additional graphite or talc.

Talc seed lubricant may be used in lieu of or in addition to graphite to reduce seed treatment buildup on seed discs and meter components. Coat seed disc and brushes with talc before installing meter. Fill hopper $\frac{1}{2}$ full of seed, add $\frac{1}{4}$ cup of talc and **mix thoroughly**. Finish filling hopper, add another $\frac{1}{4}$ cup of talc and **mix thoroughly**. Adjust rate of talc use as needed so all seeds are coated, while avoiding a buildup of talc in the bottom of the hopper. Humid conditions and/or small sized seeds with extra seed treatment may require as much as one cup of talc per hopper to prevent seed treatment buildup on seed discs and/or brushes.

NOTE: Some liquid seed treatments or inoculants may create buildup on the seed discs or brushes. Check frequently for proper population and/or seed delivery when using any liquid seed treatment. All seed treatment should be thoroughly mixed with the seed per the manufacturers' recommendations. Seed treatment dumped on top of the seed after the hopper is filled, and not mixed properly may cause bridging of the seed in the meter, reducing population or stopping the meter from planting.

SDS SEED DELIVERY SYSTEM

IMPORTANT: Use powdered graphite or talc with each fill of seed. Additional graphite or talc may be required to retard buildup of seed treatments on meter components. Frequency of monitor seed tube cleaning may be affected due to use of additional graphite or talc.

82354-1e



Powdered graphite should be added with the seed each time the bulk seed hopper is filled. Use 1 cup per hopper fill for 12 row machines and $1 \frac{1}{2}$ cup per hopper fill for 16 row machines. Graphite should be added in layers as the bulk seed hoppers are filled. The use of powdered graphite will prolong the life of the seed meter components, reduce buildup of seed treatment on components in the meter and improve seed spacing.

Talc seed lubricant may be used in lieu of or in addition to graphite to reduce seed treatment buildup on bulk fill auger system components, seed discs and other meter components and will improve meter performance. Coat seed discs and brushes with talc before installing meters. Fill each bulk hopper $\frac{1}{2}$ full of seed, add $4 \frac{1}{4}$ cups of talc for 12 row planters or $6 \frac{1}{2}$ cups of talc for 16 row planters and mix thoroughly. Finish filling bulk seed hopper, add another $4 \frac{1}{4}$ cups of talc for 12 row planters or $6 \frac{1}{2}$ cups of talc for 16 row planters. Adjust rate of talc use as needed so all seeds are coated, while avoiding a buildup of talc in the bottom of the hopper. Humid conditions and/or small sized seeds with extra seed treatment may require additional talc to prevent seed treatment buildup on auger bristles, seed discs and/or meter brushes.

SEED METER OPERATION/MAINTENANCE

SDS SEED DELIVERY SYSTEM (Continued)

NOTE: Some liquid seed treatments or inoculants may create buildup on seed discs or meter components. Check frequently for proper population and/or seed delivery when using any liquid seed treatment.

All seed treatment should be thoroughly mixed with the seed per the manufacturers' recommendations. Seed treatment dumped on top of the seed after the hopper is filled, and not mixed properly will cause bridging of the seed in the meter, reducing population or stopping the meter from planting. Additional graphite or talc may be required to retard buildup of seed treatments on meter components.

NOTE: See "Seed Lubrication" in SDS Seed Delivery System Operation section for additional information.

SEED METER CLEANOUT (Conventional Seed Hoppers)

To maintain genetic purity, thorough seed meter cleanout is important.

To clean the seed meter, disengage the seed drive and remove the seed hopper and meter. Lay the hopper on its right side.

Disassemble seed meter by rotating vacuum cover clockwise to align keyhole slots with bolt heads. Lift off cover. Remove seed disc. Empty the meter and hopper by allowing the seed to run out of the meter. Inspect brushes in meter to ensure all seed is removed. Replace seed disc and install vacuum cover.

NOTE: Use of damaged seed or seed containing foreign material will cause plugging of seed cell orifices and require more frequent seed meter cleanout to prevent underplanting.

SEED METER OPERATION/MAINTENANCE

SEED METER CLEANOUT (SDS Seed Delivery System)

To maintain genetic purity, thorough seed meter cleanout is important.

D011006301



D011006303



To clean the seed meter, remove locking pin and release latch that secures seed meter and mount.

D011006304

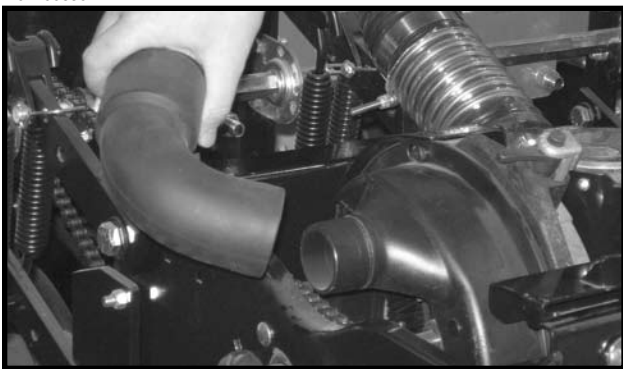

D011006305



Disconnect drop hose from seed meter and seed meter drive and remove assembly from row unit.

Disassemble vacuum cover and remove seed disc from seed meter. Allow all seed to exit meter and inspect for complete clean-out.

Reassemble.

Follow procedure on all rows.

SEED METER OPERATION/MAINTENANCE

**PLANTING RATES FOR CORN/POPCORN 39 CELL DISC
22 TOOTH CONTACT WHEEL DRIVE SPROCKET (See Page 7-1)
APPROXIMATE SEEDS/ACRE FOR VARIOUS ROW WIDTHS**

15" Rows	30" Rows	Transmission Sprockets		Recomm. Speed Range (MPH)	Average Seed Spacing In Inches
		Drive	Driven		
46,414	23,207	15	28	4 to 6	9.0
48,133	24,066	15	27	4 to 6	8.7
49,984	24,992	15	26	4 to 6	8.4
51,983	25,992	15	25	4 to 6	8.0
52,602	26,301	17	28	4 to 6	7.9
54,149	27,075	15	24	4 to 6	7.7
54,550	27,275	17	27	4 to 6	7.7
56,503	28,252	15	23	4 to 6	7.4
56,648	28,324	17	26	4 to 6	7.4
58,791	29,395	19	28	4 to 6	7.1
58,914	29,457	17	25	4 to 6	7.1
60,968	30,484	19	27	4 to 6	6.9
61,369	30,685	17	24	4 to 6	6.8
63,313	31,656	19	26	4 to 6	6.6
64,037	32,019	17	23	4 to 6	6.5
65,845	32,923	19	25	4 to 6	6.4
68,399	34,199	15	19	4 to 6	6.1
68,589	34,294	19	24	4 to 6	6.1
71,167	35,584	23	28	4 to 6	5.9
71,571	35,786	19	23	4 to 6	5.8
73,803	36,902	23	27	4 to 6	5.7
74,262	37,131	24	28	4 to 6	5.6
76,446	38,223	15	17	4 to 6	5.5
77,012	38,506	24	27	4 to 6	5.4
77,519	38,759	17	19	4 to 6	5.4
79,708	39,854	23	25	4 to 6	5.2
80,450	40,225	26	28	4 to 6	5.2
83,029	41,514	23	24	4 to 6	5.0
83,173	41,587	24	25	4 to 6	5.0
83,544	41,772	27	28	4 to 6	5.0
86,639	43,319	23	23	4 to 6	4.8
89,848	44,924	28	27	4 to 6	4.7
89,971	44,985	27	26	4 to 6	4.6
90,406	45,203	24	23	4 to 6	4.6
93,303	46,652	28	26	4 to 6	4.5
93,570	46,785	27	25	4 to 6	4.5
94,172	47,086	25	23	4 to 6	4.4
96,831	48,416	19	17	4 to 6	4.3
97,469	48,734	27	24	4 to 6	4.3
97,939	48,970	26	23	4 to 6	4.3
101,078	50,539	28	24	4 to 6	4.1
101,706	50,853	27	23	4 to 6	4.1
104,878	52,439	23	19	4 to 6	4.0
105,473	52,737	28	23	4 to 6	4.0
109,438	54,719	24	19	4 to 6	3.8
113,998	56,999	25	19	4 to 6	3.7
117,217	58,609	23	17	4 to 6	3.6
118,558	59,279	26	19	4 to 6	3.5
122,313	61,157	24	17	4 to 6	3.4
123,118	61,559	27	19	4 to 6	3.4
127,410	63,705	25	17	4 to 6	3.3
127,678	63,839	28	19	4 to 6	3.3
132,506	66,253	26	17	4 to 6	3.2
132,846	66,423	23	15	4 to 6	3.1
137,603	68,801	27	17	4 to 6	3.0

IMPORTANT: See "General Planting Rate Information" and "Checking Seed Population" pages for additional information. Always check seed population in the field to ensure planting rates are correct.

SEED METER OPERATION/MAINTENANCE

**PLANTING RATES FOR CORN/POPCORN 39 CELL DISC
28 TOOTH CONTACT WHEEL DRIVE SPROCKET (See Page 7-1)
APPROXIMATE SEEDS/ACRE FOR VARIOUS ROW WIDTHS**

15" Rows	30" Rows	Transmission Sprockets		Recomm. Speed Range (MPH)	Average Seed Spacing In Inches
		Drive	Driven		
58,791	29,395	15	28	4 to 6	7.1
60,968	30,484	15	27	4 to 6	6.9
63,313	31,656	15	26	4 to 6	6.6
65,845	32,923	15	25	4 to 6	6.4
66,629	33,315	17	28	4 to 6	6.3
68,589	34,294	15	24	4 to 6	6.1
69,097	34,549	17	27	4 to 6	6.1
71,571	35,786	15	23	4 to 6	5.8
71,755	35,877	17	26	4 to 6	5.8
74,468	37,234	19	28	4 to 6	5.6
74,625	37,312	17	25	4 to 6	5.6
77,226	38,613	19	27	4 to 6	5.4
77,734	38,867	17	24	4 to 6	5.4
80,196	40,098	19	26	4 to 6	5.2
81,114	40,557	17	23	4 to 6	5.2
83,404	41,702	19	25	4 to 6	5.0
86,639	43,319	15	19	4 to 6	4.8
86,879	43,440	19	24	4 to 6	4.8
90,145	45,073	23	28	4 to 6	4.6
90,657	45,328	19	23	4 to 6	4.6
93,484	46,742	23	27	4 to 6	4.5
94,065	47,032	24	28	4 to 6	4.4
96,831	48,416	15	17	4 to 6	4.3
97,549	48,774	24	27	4 to 6	4.3
98,191	49,095	17	19	4 to 6	4.3
100,963	50,481	23	25	4 to 6	4.1
101,904	50,952	26	28	4 to 6	4.1
105,170	52,585	23	24	4 to 6	4.0
105,353	52,676	24	25	4 to 6	4.0
105,823	52,911	27	28	4 to 6	4.0
109,742	54,871	23	23	4 to 6	3.8
113,807	56,903	28	27	4 to 6	3.7
113,963	56,982	27	26	4 to 6	3.7
114,514	57,257	24	23	4 to 6	3.7
118,184	59,092	28	26	4 to 6	3.5
118,522	59,261	27	25	4 to 6	3.5
119,285	59,643	25	23	4 to 6	3.5
122,653	61,327	19	17	4 to 6	3.4
123,460	61,730	27	24	4 to 6	3.4
124,057	62,028	26	23	4 to 6	3.4
128,033	64,016	28	24	4 to 6	3.3
128,828	64,414	27	23	4 to 6	3.2
132,846	66,423	23	19	4 to 6	3.1
133,599	66,800	28	23	4 to 6	3.1
138,622	69,311	24	19	4 to 6	3.0
144,398	72,199	25	19	4 to 6	2.9
148,475	74,237	23	17	4 to 6	2.8
150,174	75,087	26	19	4 to 6	2.8
154,930	77,465	24	17	4 to 6	2.7
155,950	77,975	27	19	4 to 6	2.7
161,386	80,693	25	17	4 to 6	2.6
161,726	80,863	28	19	4 to 6	2.6
167,841	83,921	26	17	4 to 6	2.5
168,272	84,136	23	15	4 to 6	2.5
174,297	87,148	27	17	4 to 6	2.4

IMPORTANT: See "General Planting Rate Information" and "Checking Seed Population" pages for additional information. Always check seed population in the field to ensure planting rates are correct.

SEED METER OPERATION/MAINTENANCE

**PLANTING RATES FOR LOW-RATE CORN/POPCORN 24 CELL DISC
22 TOOTH CONTACT WHEEL DRIVE SPROCKET (See Page 7-1)
APPROXIMATE SEEDS/ACRE FOR VARIOUS ROW WIDTHS**

15" Rows	30" Rows	Transmission Sprockets		Recomm. Speed Range (MPH)	Average Seed Spacing In Inches
		Drive	Driven		
28,562	14,281	15	28	4 to 6	14.6
29,620	14,810	15	27	4 to 6	14.1
30,759	15,380	15	26	4 to 6	13.6
31,990	15,995	15	25	4 to 6	13.1
32,370	16,185	17	28	4 to 6	12.9
33,323	16,661	15	24	4 to 6	12.5
33,569	16,785	17	27	4 to 6	12.5
34,771	17,386	15	23	4 to 6	12.0
34,861	17,430	17	26	4 to 6	12.0
36,179	18,089	19	28	4 to 6	11.6
36,255	18,127	17	25	4 to 6	11.5
37,519	18,759	19	27	4 to 6	11.1
37,766	18,883	17	24	4 to 6	11.1
38,962	19,481	19	26	4 to 6	10.7
39,408	19,704	17	23	4 to 6	10.6
40,520	20,260	19	25	4 to 6	10.3
42,092	21,046	15	19	4 to 6	9.9
42,209	21,104	19	24	4 to 6	9.9
43,795	21,898	23	28	4 to 6	9.5
44,044	22,022	19	23	4 to 6	9.5
45,417	22,709	23	27	4 to 6	9.2
45,700	22,850	24	28	4 to 6	9.2
47,044	23,522	15	17	4 to 6	8.9
47,392	23,696	24	27	4 to 6	8.8
47,704	23,852	17	19	4 to 6	8.8
49,051	24,525	23	25	4 to 6	8.5
49,508	24,754	26	28	4 to 6	8.4
51,095	25,547	23	24	4 to 6	8.2
51,183	25,592	24	25	4 to 6	8.2
51,412	25,706	27	28	4 to 6	8.1
53,316	26,658	23	23	4 to 6	7.8
55,291	27,645	28	27	4 to 6	7.6
55,367	27,683	27	26	4 to 6	7.6
55,634	27,817	24	23	4 to 6	7.5
57,417	28,709	28	26	4 to 6	7.3
57,581	28,791	27	25	4 to 6	7.3
57,952	28,976	25	23	4 to 6	7.2
59,589	29,794	19	17	4 to 6	7.0
59,981	29,990	27	24	4 to 6	7.0
60,270	30,135	26	23	4 to 6	6.9
62,202	31,101	28	24	4 to 6	6.7
62,588	31,294	27	23	4 to 6	6.7
64,541	32,270	23	19	4 to 6	6.5
64,907	32,453	28	23	4 to 6	6.4
67,347	33,673	24	19	4 to 6	6.2
70,153	35,076	25	19	4 to 6	6.0
72,134	36,067	23	17	4 to 6	5.8
72,959	36,479	26	19	4 to 6	5.7
75,270	37,635	24	17	4 to 6	5.6
75,765	37,883	27	19	4 to 6	5.5
78,406	39,203	25	17	4 to 6	5.3
78,571	39,286	28	19	4 to 6	5.3
81,542	40,771	26	17	4 to 6	5.1
81,751	40,876	23	15	4 to 6	5.1
84,679	42,339	27	17	4 to 6	4.9

IMPORTANT: See "General Planting Rate Information" and "Checking Seed Population" pages for additional information. Always check seed population in the field to ensure planting rates are correct.

SEED METER OPERATION/MAINTENANCE

**PLANTING RATES FOR LOW-RATE CORN/POPCORN 24 CELL DISC
28 TOOTH CONTACT WHEEL DRIVE SPROCKET (See Page 7-1)
APPROXIMATE HILLS/ACRE FOR VARIOUS ROW WIDTHS**

15" Rows	30" Rows	Transmission Sprockets		Recomm. Speed Range (MPH)	Average Seed Spacing In Inches
		Drive	Driven		
36,179	18,089	15	28	4 to 6	11.6
37,519	18,759	15	27	4 to 6	11.1
38,962	19,481	15	26	4 to 6	10.7
40,520	20,260	15	25	4 to 6	10.3
41,003	20,501	17	28	4 to 6	10.2
42,209	21,104	15	24	4 to 6	9.9
42,521	21,261	17	27	4 to 6	9.8
44,044	22,022	15	23	4 to 6	9.5
44,157	22,078	17	26	4 to 6	9.5
45,826	22,913	19	28	4 to 6	9.1
45,923	22,961	17	25	4 to 6	9.1
47,524	23,762	19	27	4 to 6	8.8
47,836	23,918	17	24	4 to 6	8.7
49,352	24,676	19	26	4 to 6	8.5
49,916	24,958	17	23	4 to 6	8.4
51,326	25,663	19	25	4 to 6	8.1
53,316	26,658	15	19	4 to 6	7.8
53,464	26,732	19	24	4 to 6	7.8
55,474	27,737	23	28	4 to 6	7.5
55,789	27,894	19	23	4 to 6	7.5
57,529	28,764	23	27	4 to 6	7.3
57,886	28,943	24	28	4 to 6	7.2
59,589	29,794	15	17	4 to 6	7.0
60,030	30,015	24	27	4 to 6	7.0
60,425	30,212	17	19	4 to 6	6.9
62,131	31,066	23	25	4 to 6	6.7
62,710	31,355	26	28	4 to 6	6.7
64,720	32,360	23	24	4 to 6	6.5
64,832	32,416	24	25	4 to 6	6.5
65,122	32,561	27	28	4 to 6	6.4
67,534	33,767	23	23	4 to 6	6.2
70,035	35,017	28	27	4 to 6	6.0
70,131	35,066	27	26	4 to 6	6.0
70,470	35,235	24	23	4 to 6	5.9
72,729	36,364	28	26	4 to 6	5.7
72,936	36,468	27	25	4 to 6	5.7
73,406	36,703	25	23	4 to 6	5.7
75,479	37,739	19	17	4 to 6	5.5
75,975	37,988	27	24	4 to 6	5.5
76,342	38,171	26	23	4 to 6	5.5
78,789	39,395	28	24	4 to 6	5.3
79,279	39,639	27	23	4 to 6	5.3
81,751	40,876	23	19	4 to 6	5.1
82,215	41,107	28	23	4 to 6	5.1
85,306	42,653	24	19	4 to 6	4.9
88,860	44,430	25	19	4 to 6	4.7
91,369	45,685	23	17	4 to 6	4.6
92,415	46,207	26	19	4 to 6	4.5
95,342	47,671	24	17	4 to 6	4.4
95,969	47,985	27	19	4 to 6	4.4
99,314	49,657	25	17	4 to 6	4.2
99,523	49,762	28	19	4 to 6	4.2
103,287	51,643	26	17	4 to 6	4.0
103,552	51,776	23	15	4 to 6	4.0
107,259	53,630	27	17	4 to 6	3.9

IMPORTANT: See "General Planting Rate Information" and "Checking Seed Population" pages for additional information. Always check seed population in the field to ensure planting rates are correct.

SEED METER OPERATION/MAINTENANCE

**PLANTING RATES FOR SOYBEAN AND MILO/GRAIN SORGHUM 60 CELL DISCS
22 TOOTH CONTACT WHEEL DRIVE SPROCKET (See Page 7-1)
APPROXIMATE SEEDS/ACRE FOR VARIOUS ROW WIDTHS**

15" Rows	30" Rows	Transmission Sprockets		Recomm. Speed Range (MPH)	Average Seed Spacing In Inches
		Drive	Driven		
71,406	35,703	15	28	4 to 6	5.9
74,050	37,025	15	27	4 to 6	5.6
76,898	38,449	15	26	4 to 6	5.4
79,974	39,987	15	25	4 to 6	5.2
80,926	40,463	17	28	4 to 6	5.2
83,306	41,653	15	24	4 to 6	5.0
83,924	41,962	17	27	4 to 6	5.0
86,928	43,464	15	23	4 to 6	4.8
87,151	43,576	17	26	4 to 6	4.8
90,447	45,223	19	28	4 to 6	4.6
90,637	45,319	17	25	4 to 6	4.6
93,797	46,898	19	27	4 to 6	4.5
94,414	47,207	17	24	4 to 6	4.4
97,404	48,702	19	26	4 to 6	4.3
98,519	49,259	17	23	4 to 6	4.2
101,301	50,650	19	25	4 to 6	4.1
105,229	52,615	15	19	4 to 6	4.0
105,521	52,761	19	24	4 to 6	4.0
109,488	54,744	23	28	4 to 6	3.8
110,109	55,055	19	23	4 to 6	3.8
113,544	56,772	23	27	4 to 6	3.7
114,249	57,124	24	28	4 to 6	3.7
117,609	58,805	15	17	4 to 6	3.6
118,480	59,240	24	27	4 to 6	3.5
119,260	59,630	17	19	4 to 6	3.5
122,627	61,314	23	25	4 to 6	3.4
123,770	61,885	26	28	4 to 6	3.4
127,737	63,868	23	24	4 to 6	3.3
127,959	63,979	24	25	4 to 6	3.3
128,530	64,265	27	28	4 to 6	3.3
133,290	66,645	23	23	4 to 6	3.1
138,227	69,113	28	27	4 to 6	3.0
138,417	69,208	27	26	4 to 6	3.0
139,086	69,543	24	23	4 to 6	3.0
143,543	71,772	28	26	4 to 6	2.9
143,954	71,977	27	25	4 to 6	2.9
144,881	72,440	25	23	4 to 6	2.9
148,971	74,486	19	17	4 to 6	2.8
149,952	74,976	27	24	4 to 6	2.8
150,676	75,338	26	23	4 to 6	2.8
155,505	77,753	28	24	4 to 6	2.7
156,471	78,236	27	23	4 to 6	2.7
161,351	80,676	23	19	4 to 6	2.6
162,266	81,133	28	23	4 to 6	2.6
168,367	84,183	24	19	4 to 6	2.5
175,382	87,691	25	19	4 to 6	2.4
180,334	90,167	23	17	4 to 6	2.3
182,397	91,199	26	19	4 to 6	2.3
188,175	94,087	24	17	4 to 6	2.2
189,413	94,706	27	19	4 to 6	2.2
196,015	98,008	25	17	4 to 6	2.1
196,428	98,214	28	19	4 to 6	2.1
203,856	101,928	26	17	4 to 6	2.1
204,378	102,189	23	15	4 to 6	2.0
211,696	105,848	27	17	4 to 6	2.0

IMPORTANT: See "General Planting Rate Information" and "Checking Seed Population" pages for additional information. Always check seed population in the field to ensure planting rates are correct.

SEED METER OPERATION/MAINTENANCE

**PLANTING RATES FOR SOYBEAN AND MILO/GRAIN SORGHUM 60 CELL DISCS
28 TOOTH CONTACT WHEEL DRIVE SPROCKET (See Page 7-1)
APPROXIMATE SEEDS/ACRE FOR VARIOUS ROW WIDTHS**

15" Rows	30" Rows	Transmission Sprockets		Recomm. Speed Range (MPH)	Average Seed Spacing In Inches
		Drive	Driven		
90,447	45,223	15	28	4 to 6	4.6
93,797	46,898	15	27	4 to 6	4.5
97,404	48,702	15	26	4 to 6	4.3
101,301	50,650	15	25	4 to 6	4.1
102,507	51,253	17	28	4 to 6	4.1
105,521	52,761	15	24	4 to 6	4.0
106,303	53,152	17	27	4 to 6	3.9
110,109	55,055	15	23	4 to 6	3.8
110,392	55,196	17	26	4 to 6	3.8
114,566	57,283	19	28	4 to 6	3.7
114,807	57,404	17	25	4 to 6	3.6
118,809	59,405	19	27	4 to 6	3.5
119,591	59,796	17	24	4 to 6	3.5
123,379	61,689	19	26	4 to 6	3.4
124,791	62,395	17	23	4 to 6	3.4
128,314	64,157	19	25	4 to 6	3.3
133,290	66,645	15	19	4 to 6	3.1
133,661	66,830	19	24	4 to 6	3.1
138,685	69,343	23	28	4 to 6	3.0
139,472	69,736	19	23	4 to 6	3.0
143,822	71,911	23	27	4 to 6	2.9
144,715	72,358	24	28	4 to 6	2.9
148,971	74,486	15	17	4 to 6	2.8
150,075	75,037	24	27	4 to 6	2.8
151,062	75,531	17	19	4 to 6	2.8
155,328	77,664	23	25	4 to 6	2.7
156,775	78,387	26	28	4 to 6	2.7
161,800	80,900	23	24	4 to 6	2.6
162,081	81,040	24	25	4 to 6	2.6
162,805	81,402	27	28	4 to 6	2.6
168,834	84,417	23	23	4 to 6	2.5
175,087	87,544	28	27	4 to 6	2.4
175,328	87,664	27	26	4 to 6	2.4
176,175	88,087	24	23	4 to 6	2.4
181,822	90,911	28	26	4 to 6	2.3
182,341	91,171	27	25	4 to 6	2.3
183,516	91,758	25	23	4 to 6	2.3
188,697	94,349	19	17	4 to 6	2.2
189,939	94,969	27	24	4 to 6	2.2
190,856	95,428	26	23	4 to 6	2.2
196,973	98,487	28	24	4 to 6	2.1
198,197	99,098	27	23	4 to 6	2.1
204,378	102,189	23	19	4 to 6	2.0
205,537	102,769	28	23	4 to 6	2.0
213,264	106,632	24	19	4 to 6	2.0
222,150	111,075	25	19	4 to 6	1.9
228,423	114,211	23	17	4 to 6	1.8
231,036	115,518	26	19	4 to 6	1.8
238,354	119,177	24	17	4 to 6	1.8
239,923	119,961	27	19	4 to 6	1.7
248,286	124,143	25	17	4 to 6	1.7
248,809	124,404	28	19	4 to 6	1.7
	129,109	26	17	4 to 6	1.6
	129,440	23	15	4 to 6	1.6
	134,074	27	17	4 to 6	1.6

IMPORTANT: See "General Planting Rate Information" and "Checking Seed Population" pages for additional information. Always check seed population in the field to ensure planting rates are correct.

SEED METER OPERATION/MAINTENANCE

**PLANTING RATES FOR SOYBEAN 60 CELL DISC
44 TOOTH CONTACT WHEEL DRIVE SPROCKET (See Page 7-1)
APPROXIMATE SEEDS/ACRE FOR VARIOUS ROW WIDTHS**

15" Rows	30" Rows	Transmission Sprockets		Recomm. Speed Range (MPH)	Average Seed Spacing In Inches
		Drive	Driven		
142,811	71,406	15	28	4 to 6	2.9
148,100	74,050	15	27	4 to 6	2.8
153,796	76,898	15	26	4 to 6	2.7
159,948	79,974	15	25	4 to 6	2.6
161,852	80,926	17	28	4 to 6	2.6
166,613	83,306	15	24	4 to 6	2.5
167,847	83,924	17	27	4 to 6	2.5
173,857	86,928	15	23	4 to 6	2.4
174,303	87,151	17	26	4 to 6	2.4
180,894	90,447	19	28	4 to 6	2.3
181,275	90,637	17	25	4 to 6	2.3
187,594	93,797	19	27	4 to 6	2.2
188,828	94,414	17	24	4 to 6	2.2
194,809	97,404	19	26	4 to 6	2.1
197,038	98,519	17	23	4 to 6	2.1
202,601	101,301	19	25	4 to 6	2.1
210,458	105,229	15	19	4 to 6	2.0
211,043	105,521	19	24	4 to 6	2.0
218,977	109,488	23	28	4 to 6	1.9
220,219	110,109	19	23	4 to 6	1.9
227,087	113,544	23	27	4 to 6	1.8
228,498	114,249	24	28	4 to 6	1.8
235,218	117,609	15	17	4 to 6	1.8
236,961	118,480	24	27	4 to 6	1.8
238,519	119,260	17	19	4 to 6	1.8
245,254	122,627	23	25	4 to 6	1.7
247,539	123,770	26	28	4 to 6	1.7
	127,737	23	24	4 to 6	1.6
	127,959	24	25	4 to 6	1.6
	128,530	27	28	4 to 6	1.6
	133,290	23	23	4 to 6	1.6
	138,227	28	27	4 to 6	1.5
	138,417	27	26	4 to 6	1.5
	139,086	24	23	4 to 6	1.5
	143,543	28	26	4 to 6	1.5
	143,954	27	25	4 to 6	1.5
	144,881	25	23	4 to 6	1.4
	148,971	19	17	4 to 6	1.4
	149,952	27	24	4 to 6	1.4
	150,676	26	23	4 to 6	1.4
NOTE: Planting rates over 250,000 seeds/acre are not recommended with subject seed disc and/or drive ratio.	155,505	28	24	4 to 6	1.3
	156,471	27	23	4 to 6	1.3
	161,351	23	19	4 to 6	1.3
	162,266	28	23	4 to 6	1.3
	168,367	24	19	4 to 6	1.2
	175,382	25	19	4 to 6	1.2
	180,334	23	17	4 to 6	1.2
	182,397	26	19	4 to 6	1.1
	188,175	24	17	4 to 6	1.1
	189,413	27	19	4 to 6	1.1
	196,015	25	17	4 to 6	1.1
	196,428	28	19	4 to 6	1.1
	203,856	26	17	4 to 6	1.0
	204,378	23	15	4 to 6	1.0
	211,696	27	17	4 to 6	1.0

IMPORTANT: See "General Planting Rate Information" and "Checking Seed Population" pages for additional information. Always check seed population in the field to ensure planting rates are correct.

SEED METER OPERATION/MAINTENANCE

**PLANTING RATES FOR HIGH-RATE SOYBEAN 120 CELL DISC
22 TOOTH CONTACT WHEEL DRIVE SPROCKET (See Page 7-1)
APPROXIMATE SEEDS/ACRE FOR VARIOUS ROW WIDTHS**

15" Rows	30" Rows	Transmission Sprockets		Recomm. Speed Range (MPH)	Average Seed Spacing In Inches
		Drive	Driven		
142,811	71,406	15	28	4 to 6	2.9
148,100	74,050	15	27	4 to 6	2.8
153,796	76,898	15	26	4 to 6	2.7
159,948	79,974	15	25	4 to 6	2.6
161,852	80,926	17	28	4 to 6	2.6
166,613	83,306	15	24	4 to 6	2.5
167,847	83,924	17	27	4 to 6	2.5
173,857	86,928	15	23	4 to 6	2.4
174,303	87,151	17	26	4 to 6	2.4
180,894	90,447	19	28	4 to 6	2.3
181,275	90,637	17	25	4 to 6	2.3
187,594	93,797	19	27	4 to 6	2.2
188,828	94,414	17	24	4 to 6	2.2
194,809	97,404	19	26	4 to 6	2.1
197,038	98,519	17	23	4 to 6	2.1
202,601	101,301	19	25	4 to 6	2.1
210,458	105,229	15	19	4 to 6	2.0
211,043	105,521	19	24	4 to 6	2.0
218,977	109,488	23	28	4 to 6	1.9
220,219	110,109	19	23	4 to 6	1.9
227,087	113,544	23	27	4 to 6	1.8
228,498	114,249	24	28	4 to 6	1.8
235,218	117,609	15	17	4 to 6	1.8
236,961	118,480	24	27	4 to 6	1.8
238,519	119,260	17	19	4 to 6	1.8
245,254	122,627	23	25	4 to 6	1.7
247,539	123,770	26	28	4 to 6	1.7
	127,737	23	24	4 to 6	1.6
	127,959	24	25	4 to 6	1.6
	128,530	27	28	4 to 6	1.6
	133,290	23	23	4 to 6	1.6
	138,227	28	27	4 to 6	1.5
	138,417	27	26	4 to 6	1.5
	139,086	24	23	4 to 6	1.5
	143,543	28	26	4 to 6	1.5
	143,954	27	25	4 to 6	1.5
	144,881	25	23	4 to 6	1.4
	148,971	19	17	4 to 6	1.4
	149,952	27	24	4 to 6	1.4
	150,676	26	23	4 to 6	1.4
	155,505	28	24	4 to 6	1.3
	156,471	27	23	4 to 6	1.3
	161,351	23	19	4 to 6	1.3
	162,266	28	23	4 to 6	1.3
NOTE: Planting rates over 250,000 seeds/acre are not recommended with subject seed disc and/or drive ratio.	168,367	24	19	4 to 6	1.2
	175,382	25	19	4 to 6	1.2
	180,334	23	17	4 to 6	1.2
	182,397	26	19	4 to 6	1.1
	188,175	24	17	4 to 6	1.1
	189,413	27	19	4 to 6	1.1
	196,015	25	17	4 to 6	1.1
	196,428	28	19	4 to 6	1.1
	203,856	26	17	4 to 6	1.0
	204,378	23	15	4 to 6	1.0
	211,696	27	17	4 to 6	1.0

IMPORTANT: See "General Planting Rate Information" and "Checking Seed Population" pages for additional information. Always check seed population in the field to ensure planting rates are correct.

SEED METER OPERATION/MAINTENANCE

**PLANTING RATES FOR HIGH-RATE SOYBEAN 120 CELL DISC
28 TOOTH CONTACT WHEEL DRIVE SPROCKET (See Page 7-1)
APPROXIMATE SEEDS/ACRE FOR VARIOUS ROW WIDTHS**

15" Rows	30" Rows	Transmission Sprockets		Recomm. Speed Range (MPH)	Average Seed Spacing In Inches
		Drive	Driven		
180,894	90,447	15	28	4 to 6	2.3
187,594	93,797	15	27	4 to 6	2.2
194,809	97,404	15	26	4 to 6	2.1
202,601	101,301	15	25	4 to 6	2.1
205,013	102,507	17	28	4 to 6	2.0
211,043	105,521	15	24	4 to 6	2.0
212,606	106,303	17	27	4 to 6	2.0
220,219	110,109	15	23	4 to 6	1.9
220,783	110,392	17	26	4 to 6	1.9
229,132	114,566	19	28	4 to 6	1.8
229,615	114,807	17	25	4 to 6	1.8
237,619	118,809	19	27	4 to 6	1.8
239,182	119,591	17	24	4 to 6	1.7
246,758	123,379	19	26	4 to 6	1.7
249,581	124,791	17	23	4 to 6	1.7
	128,314	19	25	4 to 6	1.6
	133,290	15	19	4 to 6	1.6
	133,661	19	24	4 to 6	1.6
	138,685	23	28	4 to 6	1.5
	139,472	19	23	4 to 6	1.5
	143,822	23	27	4 to 6	1.5
	144,715	24	28	4 to 6	1.4
	148,971	15	17	4 to 6	1.4
	150,075	24	27	4 to 6	1.4
	151,062	17	19	4 to 6	1.4
	155,328	23	25	4 to 6	1.3
	156,775	26	28	4 to 6	1.3
	161,800	23	24	4 to 6	1.3
	162,081	24	25	4 to 6	1.3
	162,805	27	28	4 to 6	1.3
	168,834	23	23	4 to 6	1.2
	175,087	28	27	4 to 6	1.2
NOTE: Planting rates over 250,000 seeds/acre are not recommended with subject seed disc and/or drive ratio.	175,328	27	26	4 to 6	1.2
	176,175	24	23	4 to 6	1.2
	181,822	28	26	4 to 6	1.1
	182,341	27	25	4 to 6	1.1
	183,516	25	23	4 to 6	1.1
	188,697	19	17	4 to 6	1.1
	189,939	27	24	4 to 6	1.1
	190,856	26	23	4 to 6	1.1
	196,973	28	24	4 to 6	1.1
	198,197	27	23	4 to 6	1.1
	204,378	23	19	4 to 6	1.0
	205,537	28	23	4 to 6	1.0
	213,264	24	19	4 to 6	1.0
	222,150	25	19	4 to 6	0.9
	228,423	23	17	4 to 6	0.9
	231,036	26	19	4 to 6	0.9
	238,354	24	17	4 to 6	0.9
	239,923	27	19	4 to 6	0.9
	248,286	25	17	4 to 6	0.8
	248,809	28	19	4 to 6	0.8
	258,217	26	17	4 to 6	0.8
	258,879	23	15	4 to 6	0.8
	268,149	27	17	4 to 6	0.8

IMPORTANT: See "General Planting Rate Information" and "Checking Seed Population" pages for additional information. Always check seed population in the field to ensure planting rates are correct.

SEED METER OPERATION/MAINTENANCE

**PLANTING RATES FOR ACID-DELINTED HILL-DROP COTTON (3 SEEDS PER CELL), 20 CELL DISC
22 TOOTH CONTACT WHEEL DRIVE SPROCKET (See Page 7-1)
APPROXIMATE HILLS/ACRE FOR VARIOUS ROW WIDTHS**

15" Rows	30" Rows	Transmission Sprockets		Recomm. Speed Range (MPH)	Average Hill Spacing In Inches
		Drive	Driven		
23,802	11,901	15	28	4 to 6	17.6
24,683	12,342	15	27	4 to 6	16.9
25,633	12,816	15	26	4 to 6	16.3
26,658	13,329	15	25	4 to 6	15.7
26,975	13,488	17	28	4 to 6	15.5
27,769	13,884	15	24	4 to 6	15.1
27,975	13,987	17	27	4 to 6	14.9
28,976	14,488	15	23	4 to 6	14.4
29,050	14,525	17	26	4 to 6	14.4
30,149	15,074	19	28	4 to 6	13.9
30,212	15,106	17	25	4 to 6	13.8
31,266	15,633	19	27	4 to 6	13.4
31,471	15,736	17	24	4 to 6	13.3
32,468	16,234	19	26	4 to 6	12.9
32,840	16,420	17	23	4 to 6	12.7
33,767	16,883	19	25	4 to 6	12.4
35,076	17,538	15	19	4 to 6	11.9
35,174	17,587	19	24	4 to 6	11.9
36,496	18,248	23	28	4 to 6	11.5
36,703	18,352	19	23	4 to 6	11.4
37,848	18,924	23	27	4 to 6	11.0
38,083	19,041	24	28	4 to 6	11.0
39,203	19,602	15	17	4 to 6	10.7
39,304	19,652	23	26	4 to 6	10.6
39,493	19,747	24	27	4 to 6	10.6
39,670	19,835	25	28	4 to 6	10.5
39,753	19,877	17	19	4 to 6	10.5
40,876	20,438	23	25	4 to 6	10.2
41,012	20,506	24	26	4 to 6	10.2
41,139	20,569	25	27	4 to 6	10.2
41,257	20,628	26	28	4 to 6	10.1
42,579	21,289	23	24	4 to 6	9.8
42,653	21,326	24	25	4 to 6	9.8
42,721	21,361	25	26	4 to 6	9.8
42,785	21,392	26	27	4 to 6	9.8
42,843	21,422	27	28	4 to 6	9.8
44,430	22,215	23	23	4 to 6	9.4
46,076	23,038	28	27	4 to 6	9.1
46,139	23,069	27	26	4 to 6	9.1
46,281	23,141	25	24	4 to 6	9.0
46,362	23,181	24	23	4 to 6	9.0
47,848	23,924	28	26	4 to 6	8.7
47,985	23,992	27	25	4 to 6	8.7
48,294	24,147	25	23	4 to 6	8.7
49,657	24,829	19	17	4 to 6	8.4
49,762	24,881	28	25	4 to 6	8.4
49,984	24,992	27	24	4 to 6	8.4
50,225	25,113	26	23	4 to 6	8.3
51,835	25,918	28	24	4 to 6	8.1
52,157	26,079	27	23	4 to 6	8.0
53,784	26,892	23	19	4 to 6	7.8
54,089	27,044	28	23	4 to 6	7.7
56,122	28,061	24	19	4 to 6	7.5
58,461	29,230	25	19	4 to 6	7.2
60,111	30,056	23	17	4 to 6	7.0

IMPORTANT: See "General Planting Rate Information" and "Checking Seed Population" pages for additional information. Always check seed population in the field to ensure planting rates are correct.

SEED METER OPERATION/MAINTENANCE

**PLANTING RATES FOR HILL-DROP COTTON (3 SEEDS PER CELL), 20 CELL DISC
28 TOOTH CONTACT WHEEL DRIVE SPROCKET (See Page 7-1)
APPROXIMATE HILLS/ACRE FOR VARIOUS ROW WIDTHS**

15" Rows	30" Rows	Transmission Sprockets		Recomm. Speed Range (MPH)	Average Hill Spacing In Inches
		Drive	Driven		
30,149	15,074	15	28	4 to 6	13.9
31,266	15,633	15	27	4 to 6	13.4
32,468	16,234	15	26	4 to 6	12.9
33,767	16,883	15	25	4 to 6	12.4
34,169	17,084	17	28	4 to 6	12.2
35,174	17,587	15	24	4 to 6	11.9
35,434	17,717	17	27	4 to 6	11.8
36,703	18,352	15	23	4 to 6	11.4
36,797	18,399	17	26	4 to 6	11.4
38,189	19,094	19	28	4 to 6	11.0
38,269	19,135	17	25	4 to 6	10.9
39,603	19,802	19	27	4 to 6	10.6
39,864	19,932	17	24	4 to 6	10.5
41,126	20,563	19	26	4 to 6	10.2
41,597	20,798	17	23	4 to 6	10.1
42,771	21,386	19	25	4 to 6	9.8
44,430	22,215	15	19	4 to 6	9.4
44,554	22,277	19	24	4 to 6	9.4
46,228	23,114	23	28	4 to 6	9.0
46,491	23,245	19	23	4 to 6	9.0
47,941	23,970	23	27	4 to 6	8.7
48,238	24,119	24	28	4 to 6	8.7
49,657	24,829	15	17	4 to 6	8.4
49,784	24,892	23	26	4 to 6	8.4
50,025	25,012	24	27	4 to 6	8.4
50,248	25,124	25	28	4 to 6	8.3
50,354	25,177	17	19	4 to 6	8.3
51,776	25,888	23	25	4 to 6	8.1
51,949	25,975	24	26	4 to 6	8.0
52,109	26,055	25	27	4 to 6	8.0
52,258	26,129	26	28	4 to 6	8.0
53,933	26,967	23	24	4 to 6	7.8
54,027	27,013	24	25	4 to 6	7.7
54,114	27,057	25	26	4 to 6	7.7
54,194	27,097	26	27	4 to 6	7.7
54,268	27,134	27	28	4 to 6	7.7
56,278	28,139	23	23	4 to 6	7.4
58,362	29,181	28	27	4 to 6	7.2
58,443	29,221	27	26	4 to 6	7.2
58,623	29,312	25	24	4 to 6	7.1
58,725	29,362	24	23	4 to 6	7.1
60,607	30,304	28	26	4 to 6	6.9
60,780	30,390	27	25	4 to 6	6.9
61,172	30,586	25	23	4 to 6	6.8
62,899	31,450	19	17	4 to 6	6.6
63,031	31,516	28	25	4 to 6	6.6
63,313	31,656	27	24	4 to 6	6.6
63,619	31,809	26	23	4 to 6	6.6
65,658	32,829	28	24	4 to 6	6.4
66,066	33,033	27	23	4 to 6	6.3
68,126	34,063	23	19	4 to 6	6.1
68,512	34,256	28	23	4 to 6	6.1
71,088	35,544	24	19	4 to 6	5.9
74,050	37,025	25	19	4 to 6	5.6
76,141	38,070	23	17	4 to 6	5.5

IMPORTANT: See "General Planting Rate Information" and "Checking Seed Population" pages for additional information. Always check seed population in the field to ensure planting rates are correct.

SEED METER OPERATION/MAINTENANCE

**PLANTING RATES FOR COTTON/SMALL DRY EDIBLE BEAN 54 CELL DISC
22 TOOTH CONTACT WHEEL DRIVE SPROCKET (See Page 7-1)
APPROXIMATE SEEDS/ACRE FOR VARIOUS ROW WIDTHS**

15" Rows	30" Rows	Transmission Sprockets		Recomm. Speed Range (MPH)	Average Seed Spacing In Inches
		Drive	Driven		
64,265	32,132	15	28	4 to 6	6.5
66,645	33,323	15	27	4 to 6	6.3
69,208	34,604	15	26	4 to 6	6.0
71,977	35,988	15	25	4 to 6	5.8
72,834	36,417	17	28	4 to 6	5.7
74,976	37,488	15	24	4 to 6	5.6
75,531	37,766	17	27	4 to 6	5.5
78,236	39,118	15	23	4 to 6	5.3
78,436	39,218	17	26	4 to 6	5.3
81,402	40,701	19	28	4 to 6	5.1
81,574	40,787	17	25	4 to 6	5.1
84,417	42,209	19	27	4 to 6	5.0
84,973	42,486	17	24	4 to 6	4.9
87,664	43,832	19	26	4 to 6	4.8
88,667	44,334	17	23	4 to 6	4.7
91,171	45,585	19	25	4 to 6	4.6
94,706	47,353	15	19	4 to 6	4.4
94,969	47,485	19	24	4 to 6	4.4
98,540	49,270	23	28	4 to 6	4.2
99,098	49,549	19	23	4 to 6	4.2
102,189	51,095	23	27	4 to 6	4.1
102,824	51,412	24	28	4 to 6	4.1
105,848	52,924	15	17	4 to 6	4.0
106,632	53,316	24	27	4 to 6	3.9
107,334	53,667	17	19	4 to 6	3.9
110,364	55,182	23	25	4 to 6	3.8
111,393	55,696	26	28	4 to 6	3.8
114,963	57,481	23	24	4 to 6	3.6
115,163	57,581	24	25	4 to 6	3.6
115,677	57,838	27	28	4 to 6	3.6
119,961	59,981	23	23	4 to 6	3.5
124,404	62,202	28	27	4 to 6	3.4
124,575	62,288	27	26	4 to 6	3.4
125,177	62,588	24	23	4 to 6	3.3
129,189	64,595	28	26	4 to 6	3.2
129,558	64,779	27	25	4 to 6	3.2
130,393	65,196	25	23	4 to 6	3.2
134,074	67,037	19	17	4 to 6	3.1
134,956	67,478	27	24	4 to 6	3.1
135,608	67,804	26	23	4 to 6	3.1
139,955	69,977	28	24	4 to 6	3.0
140,824	70,412	27	23	4 to 6	3.0
145,216	72,608	23	19	4 to 6	2.9
146,040	73,020	28	23	4 to 6	2.9
151,530	75,765	24	19	4 to 6	2.8
157,844	78,922	25	19	4 to 6	2.6
162,301	81,150	23	17	4 to 6	2.6
164,158	82,079	26	19	4 to 6	2.5
169,357	84,679	24	17	4 to 6	2.5
170,471	85,236	27	19	4 to 6	2.5
176,414	88,207	25	17	4 to 6	2.4
176,785	88,393	28	19	4 to 6	2.4
183,470	91,735	26	17	4 to 6	2.3
183,941	91,970	23	15	4 to 6	2.3
190,527	95,263	27	17	4 to 6	2.2

IMPORTANT: See "General Planting Rate Information" and "Checking Seed Population" pages for additional information. Always check seed population in the field to ensure planting rates are correct.

SEED METER OPERATION/MAINTENANCE

**PLANTING RATES FOR COTTON/SMALL DRY EDIBLE BEAN 54 CELL DISC
28 TOOTH CONTACT WHEEL DRIVE SPROCKET (See Page 7-1)
APPROXIMATE SEEDS/ACRE FOR VARIOUS ROW WIDTHS**

15" Rows	30" Rows	Transmission Sprockets		Recomm. Speed Range (MPH)	Average Seed Spacing In Inches
		Drive	Driven		
81,402	40,701	15	28	4 to 6	5.1
84,417	42,209	15	27	4 to 6	5.0
87,664	43,832	15	26	4 to 6	4.8
91,171	45,585	15	25	4 to 6	4.6
92,256	46,128	17	28	4 to 6	4.5
94,969	47,485	15	24	4 to 6	4.4
95,673	47,836	17	27	4 to 6	4.4
99,098	49,549	15	23	4 to 6	4.2
99,353	49,676	17	26	4 to 6	4.2
103,110	51,555	19	28	4 to 6	4.1
103,327	51,663	17	25	4 to 6	4.0
106,928	53,464	19	27	4 to 6	3.9
107,632	53,816	17	24	4 to 6	3.9
111,041	55,521	19	26	4 to 6	3.8
112,312	56,156	17	23	4 to 6	3.7
115,483	57,741	19	25	4 to 6	3.6
119,961	59,981	15	19	4 to 6	3.5
120,294	60,147	19	24	4 to 6	3.5
124,817	62,408	23	28	4 to 6	3.4
125,525	62,762	19	23	4 to 6	3.3
129,440	64,720	23	27	4 to 6	3.2
130,244	65,122	24	28	4 to 6	3.2
134,074	67,037	15	17	4 to 6	3.1
135,067	67,534	24	27	4 to 6	3.1
135,956	67,978	17	19	4 to 6	3.1
139,795	69,897	23	25	4 to 6	3.0
141,097	70,549	26	28	4 to 6	3.0
145,620	72,810	23	24	4 to 6	2.9
145,873	72,936	24	25	4 to 6	2.9
146,524	73,262	27	28	4 to 6	2.9
151,951	75,975	23	23	4 to 6	2.8
157,579	78,789	28	27	4 to 6	2.7
157,795	78,898	27	26	4 to 6	2.7
158,557	79,279	24	23	4 to 6	2.6
163,639	81,820	28	26	4 to 6	2.6
164,107	82,053	27	25	4 to 6	2.5
165,164	82,582	25	23	4 to 6	2.5
169,828	84,914	19	17	4 to 6	2.5
170,945	85,472	27	24	4 to 6	2.4
171,771	85,885	26	23	4 to 6	2.4
177,276	88,638	28	24	4 to 6	2.4
178,377	89,189	27	23	4 to 6	2.3
183,941	91,970	23	19	4 to 6	2.3
184,984	92,492	28	23	4 to 6	2.3
191,938	95,969	24	19	4 to 6	2.2
199,935	99,968	25	19	4 to 6	2.1
205,581	102,790	23	17	4 to 6	2.0
207,933	103,966	26	19	4 to 6	2.0
214,519	107,259	24	17	4 to 6	1.9
215,930	107,965	27	19	4 to 6	1.9
223,457	111,729	25	17	4 to 6	1.9
223,928	111,964	28	19	4 to 6	1.9
232,396	116,198	26	17	4 to 6	1.8
232,991	116,496	23	15	4 to 6	1.8
241,334	120,667	27	17	4 to 6	1.7

IMPORTANT: See "General Planting Rate Information" and "Checking Seed Population" pages for additional information. Always check seed population in the field to ensure planting rates are correct.

SEED METER OPERATION/MAINTENANCE

**PLANTING RATES FOR LARGE DRY EDIBLE BEAN 54 CELL DISC
22 TOOTH CONTACT WHEEL DRIVE SPROCKET (See Page 7-1)
APPROXIMATE SEEDS/ACRE FOR VARIOUS ROW WIDTHS**

15" Rows	30" Rows	Transmission Sprockets		Recomm. Speed Range (MPH)	Average Seed Spacing In Inches
		Drive	Driven		
64,265	32,132	15	28	4 to 6	6.5
66,645	33,323	15	27	4 to 6	6.3
69,208	34,604	15	26	4 to 6	6.0
71,977	35,988	15	25	4 to 6	5.8
72,834	36,417	17	28	4 to 6	5.7
74,976	37,488	15	24	4 to 6	5.6
75,531	37,766	17	27	4 to 6	5.5
78,236	39,118	15	23	4 to 6	5.3
78,436	39,218	17	26	4 to 6	5.3
81,402	40,701	19	28	4 to 6	5.1
81,574	40,787	17	25	4 to 6	5.1
84,417	42,209	19	27	4 to 6	5.0
84,973	42,486	17	24	4 to 6	4.9
87,664	43,832	19	26	4 to 6	4.8
88,667	44,334	17	23	4 to 6	4.7
91,171	45,585	19	25	4 to 6	4.6
94,706	47,353	15	19	4 to 6	4.4
94,969	47,485	19	24	4 to 6	4.4
98,540	49,270	23	28	4 to 6	4.2
99,098	49,549	19	23	4 to 6	4.2
102,189	51,095	23	27	4 to 6	4.1
102,824	51,412	24	28	4 to 6	4.1
105,848	52,924	15	17	4 to 6	4.0
106,632	53,316	24	27	4 to 6	3.9
107,334	53,667	17	19	4 to 6	3.9
110,364	55,182	23	25	4 to 6	3.8
111,393	55,696	26	28	4 to 6	3.8
114,963	57,481	23	24	4 to 6	3.6
115,163	57,581	24	25	4 to 6	3.6
115,677	57,838	27	28	4 to 6	3.6
119,961	59,981	23	23	4 to 6	3.5
124,404	62,202	28	27	4 to 6	3.4
124,575	62,288	27	26	4 to 6	3.4
125,177	62,588	24	23	4 to 6	3.3
129,189	64,595	28	26	4 to 6	3.2
129,558	64,779	27	25	4 to 6	3.2
130,393	65,196	25	23	4 to 6	3.2
134,074	67,037	19	17	4 to 6	3.1
134,956	67,478	27	24	4 to 6	3.1
135,608	67,804	26	23	4 to 6	3.1
139,955	69,977	28	24	4 to 6	3.0
140,824	70,412	27	23	4 to 6	3.0
145,216	72,608	23	19	4 to 6	2.9
146,040	73,020	28	23	4 to 6	2.9
151,530	75,765	24	19	4 to 6	2.8
157,844	78,922	25	19	4 to 6	2.6
162,301	81,150	23	17	4 to 6	2.6
164,158	82,079	26	19	4 to 6	2.5
169,357	84,679	24	17	4 to 6	2.5
170,471	85,236	27	19	4 to 6	2.5
176,414	88,207	25	17	4 to 6	2.4
176,785	88,393	28	19	4 to 6	2.4
183,470	91,735	26	17	4 to 6	2.3
183,941	91,970	23	15	4 to 6	2.3
190,527	95,263	27	17	4 to 6	2.2

IMPORTANT: See "General Planting Rate Information" and "Checking Seed Population" pages for additional information. Always check seed population in the field to ensure planting rates are correct.

SEED METER OPERATION/MAINTENANCE

**PLANTING RATES FOR LARGE DRY EDIBLE BEAN 54 CELL DISC
28 TOOTH CONTACT WHEEL DRIVE SPROCKET (See Page 7-1)
APPROXIMATE SEEDS/ACRE FOR VARIOUS ROW WIDTHS**

15" Rows	30" Rows	Transmission Sprockets		Recomm. Speed Range (MPH)	Average Seed Spacing In Inches
		Drive	Driven		
81,402	40,701	15	28	4 to 6	5.1
84,417	42,209	15	27	4 to 6	5.0
87,664	43,832	15	26	4 to 6	4.8
91,171	45,585	15	25	4 to 6	4.6
92,256	46,128	17	28	4 to 6	4.5
94,969	47,485	15	24	4 to 6	4.4
95,673	47,836	17	27	4 to 6	4.4
99,098	49,549	15	23	4 to 6	4.2
99,353	49,676	17	26	4 to 6	4.2
103,110	51,555	19	28	4 to 6	4.1
103,327	51,663	17	25	4 to 6	4.0
106,928	53,464	19	27	4 to 6	3.9
107,632	53,816	17	24	4 to 6	3.9
111,041	55,521	19	26	4 to 6	3.8
112,312	56,156	17	23	4 to 6	3.7
115,483	57,741	19	25	4 to 6	3.6
119,961	59,981	15	19	4 to 6	3.5
120,294	60,147	19	24	4 to 6	3.5
124,817	62,408	23	28	4 to 6	3.4
125,525	62,762	19	23	4 to 6	3.3
129,440	64,720	23	27	4 to 6	3.2
130,244	65,122	24	28	4 to 6	3.2
134,074	67,037	15	17	4 to 6	3.1
135,067	67,534	24	27	4 to 6	3.1
135,956	67,978	17	19	4 to 6	3.1
139,795	69,897	23	25	4 to 6	3.0
141,097	70,549	26	28	4 to 6	3.0
145,620	72,810	23	24	4 to 6	2.9
145,873	72,936	24	25	4 to 6	2.9
146,524	73,262	27	28	4 to 6	2.9
151,951	75,975	23	23	4 to 6	2.8
157,579	78,789	28	27	4 to 6	2.7
157,795	78,898	27	26	4 to 6	2.7
158,557	79,279	24	23	4 to 6	2.6
163,639	81,820	28	26	4 to 6	2.6
164,107	82,053	27	25	4 to 6	2.5
165,164	82,582	25	23	4 to 6	2.5
169,828	84,914	19	17	4 to 6	2.5
170,945	85,472	27	24	4 to 6	2.4
171,771	85,885	26	23	4 to 6	2.4
177,276	88,638	28	24	4 to 6	2.4
178,377	89,189	27	23	4 to 6	2.3
183,941	91,970	23	19	4 to 6	2.3
184,984	92,492	28	23	4 to 6	2.3
191,938	95,969	24	19	4 to 6	2.2
199,935	99,968	25	19	4 to 6	2.1
205,581	102,790	23	17	4 to 6	2.0
207,933	103,966	26	19	4 to 6	2.0
214,519	107,259	24	17	4 to 6	1.9
215,930	107,965	27	19	4 to 6	1.9
223,457	111,729	25	17	4 to 6	1.9
223,928	111,964	28	19	4 to 6	1.9
232,396	116,198	26	17	4 to 6	1.8
232,991	116,496	23	15	4 to 6	1.8
241,334	120,667	27	17	4 to 6	1.7

IMPORTANT: See "General Planting Rate Information" and "Checking Seed Population" pages for additional information. Always check seed population in the field to ensure planting rates are correct.

SEED METER OPERATION/MAINTENANCE

DRY INSECTICIDE APPLICATION RATES APPROXIMATE POUNDS/ACRE AT 5 MPH FOR 30" ROW WIDTH

Meter Setting	30" Rows
CLAY GRANULES	
10	4.9
11	5.4
12	6.1
13	6.9
14	7.7
15	8.5
16	9.6
17	10.7
18	11.4
19	13.1
20	14.2
21	15.5
22	16.4
23	17.2
24	18.8
25	20.9
26	23.0
27	24.1
28	25.4
29	27.8
30	29.6
SAND GRANULES	
5	2.9
6	4.9
7	5.3
8	6.3
9	7.8
10	8.9
11	10.2
12	11.2
13	12.6
14	14.1
15	15.5
16	17.5
17	19.4
18	21.8
19	24.3
20	25.7
21	27.6
22	29.6
23	32.0
24	34.4
25	36.9

NOTE: The above chart represents average values and should be used only as a starting point. The granular chemical flows through the given meter opening at a nearly uniform rate regardless of roller speed. Your actual rate will vary depending upon the insecticide you are using, your planting speed and your plant population. Planting speed/ground speed has the greatest effect on application rate.

Your actual rate must be checked in the field with the actual insecticide that you are using and at the speed and population at which you will be planting. See "Checking Granular Chemical Application Rate" page for additional information.



WARNING: Agricultural chemicals can be dangerous if not selected and handled with care. Always read and follow directions supplied by the chemical manufacturer.

SEED METER OPERATION/MAINTENANCE

DRY HERBICIDE APPLICATION RATES

APPROXIMATE POUNDS/ACRE AT 5 MPH FOR 30" ROW WIDTH

CLAY GRANULES

Meter Setting	30" Rows
10	4.7
11	5.2
12	5.8
13	6.5
14	7.3
15	8.2
16	9.0
17	9.9
18	10.7
19	11.6
20	12.6
21	13.6
22	14.6
23	15.7
24	17.0
25	18.1
26	19.4
27	20.9
28	22.6
29	24.3
30	26.7

NOTE: The above chart represents average values and should be used only as a starting point. The granular chemical flows through the given meter opening at a nearly uniform rate regardless of roller speed. Your actual rate will vary depending upon the herbicide you are using, your planting speed and your plant population. Planting speed/ground speed has the greatest effect on application rate.

Your actual rate must be checked in the field with the actual herbicide that you are using and at the speed and population at which you will be planting. See "Checking Granular Chemical Application Rate" page for additional information.



WARNING: Agricultural chemicals can be dangerous if not selected and handled with care. Always read and follow directions supplied by the chemical manufacturer.

SEED METER OPERATION/MAINTENANCE

**See “Liquid Fertilizer Rate Chart”
in Machine Operation section.**

SEED METER OPERATION/MAINTENANCE

SEED METER SINGULATOR BRUSH AND VACUUM LEVEL ADJUSTMENTS

SEED DISC SELECTION

CROP	CELLS	SEED SIZE RANGE	COLOR-CODE
Corn	39	35 To 70 Lbs./80,000 Kernel Count Unit	Light Blue
Low-Rate Corn	24	35 To 70 Lbs./80,000 Kernel Count Unit	Light Green
Popcorn	39	2210 To 4200 Seeds/Lb.	Light Blue
Low-Rate Popcorn	24	2210 To 4200 Seeds/Lb.	Light Green
Soybean	60	2200 To 4000 Seeds/Lb.	Black
High-Rate Soybean	120	2200 To 4000 Seeds/Lb.	Dark Blue
Milo/Grain Sorghum	60	10,000 To 20,000 Seeds/Lb.	Yellow
Hill-Drop Cotton, Acid-Delinted (3 Seeds Per Cell)	20	3800 To 5200 Seeds/Lb.	Brown
Cotton, Acid-Delinted	54	3800 To 5200 Seeds/Lb.	Dark Green
Dry Edible Bean (Small)	54	1200 To 2500 Seeds/Lb.	Dark Green
Dry Edible Bean (Large)	54	800 To 1200 Seeds/Lb.	Tan

EDGEVAC® INITIAL SETTINGS

CROP	SIZE	SINGULATOR SEED DISC	VACUUM BRUSH SETTING	SETTING (H ₂ O)	SEE NOTES
Corn	35-45 Lbs./80K	Corn/Popcorn	7	20	4, 5
	45-60 Lbs./80K	Corn/Popcorn	6	20	4, 5
	60-70 Lbs./80K	Corn/Popcorn	5	20	4, 5
Popcorn	2210-4200 Seeds/Lb.	Corn/Popcorn	9	18	1, 4, 5
Soybeans	2200-4000 Seeds/Lb.	Soybean	5	10	1
Milo/Grain Sorghum	10,000-20,000 Seeds/Lb.	Milo/Grain Sorghum	7	18	1, 2
Hill-Drop Cotton	3800-5200 Seeds/Lb.	Hill-Drop Cotton	8	23	3
Cotton	3800-5200 Seeds/Lb.	Cotton	8	20	3
Edible Beans	800-1200 Seeds/Lb.	Large Edible Bean	5	18	5
	1200-2500 Seeds/Lb.	Small Edible Bean	6	18	3, 5

NOTES:

1. Requires use of seed meter baffle. Refer to page 7-3 for additional information.
2. Requires use of cleanout brush. Refer to page 7-3 for additional information.
3. Requires use of cleanout brush w/ball-type ejector. Refer to page 7-3 for additional information.
4. For flat seeds, higher vacuum level may be required.
5. Larger seeds may require a lower numbered singulator brush setting from the initial setting. Smaller seeds may require a higher numbered setting.

Refer to the planting rate charts in this manual for seed drive transmission sprocket combinations.

IMPORTANT: See “General Planting Rate Information” and “Checking Seed Population” pages for additional information. Always check seed population in the field to ensure planting rates are correct.

NOTE: Singulator brush settings are marked from 1 thru 11. The lower the singulator brush setting, the less aggressive. The higher singulator brush settings are the most aggressive. Refer to illustrations on page 7-26.

NOTE: Optimum meter performance will be attained with consistent seed size and shape. A mixture of seed sizes and shapes will affect meter performance.

NOTE: Use 1 tablespoon powdered graphite with each hopper fill of seed. Seed treatment, foreign material, dirt or seed chaff may cause gradual reduction of seed disc fill (population). See “Seed Meter”.

NOTE: Excessive seed treatment, humidity and light-weight seed can affect meter performance. Use ½ cup of talc with each hopper fill of seed and mix thoroughly so that all seeds are coated, adjust rates as needed. Use of talc will aid the seed flow into the meter, singulation and seed drop from the disc.

SEED METER OPERATION/MAINTENANCE

STEP 1 Select seed disc (and seed meter baffle, cleanout brush and/or cleanout brush w/ball-type ejector if applicable) to match crop and population.

STEP 2 Adjust the singulator brush to initial setting. Note that seed size, seed shape, seed treatments, travel speed and planting rate will all affect meter performance.

D06260660

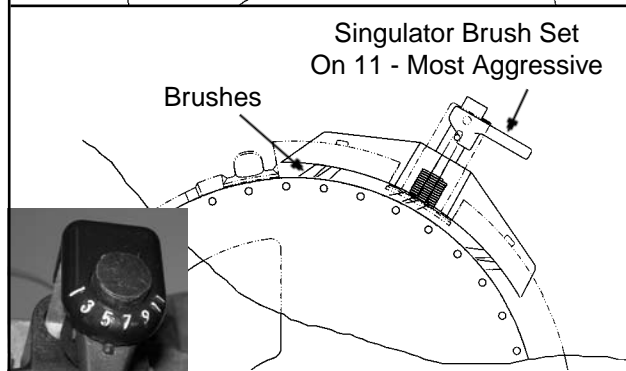
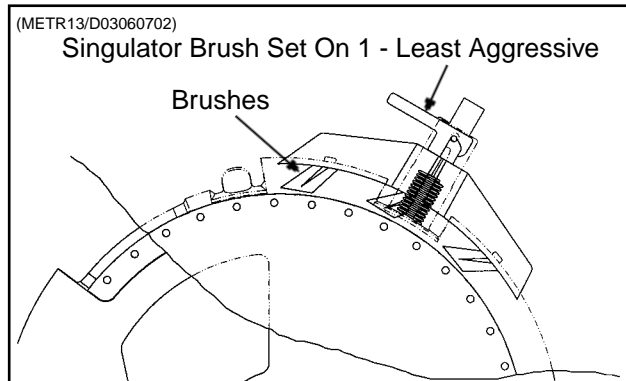
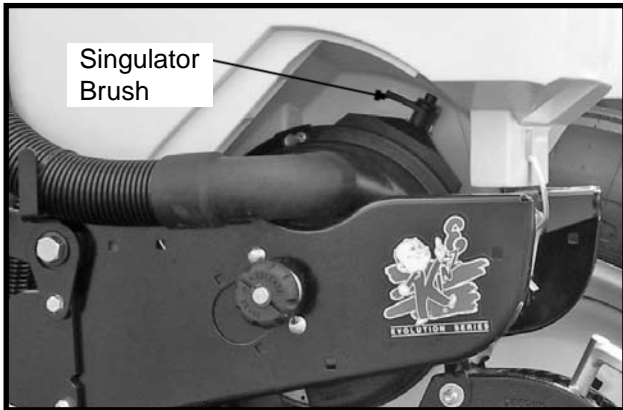

STEP 3 With vacuum fan running, lower planter to planting position and drive forward a short distance to load seed into the seed disc cells.

Adjust vacuum level to the initial setting according to the tables on preceding page. Note that seed size, seed shape, seed treatments, travel speed and planting rate will all affect meter performance.

NOTE: Vacuum reading will be much lower when seed disc cells are empty. Prior to setting vacuum level, load all seed cells.

D10240583



See "Digital Vacuum Gauge Operation" in Machine Operation section

NOTE: Operate vacuum fan 3-5 minutes to bring oil up to normal operating temperature prior to making the final vacuum level adjustment.

STEP 4 Perform optional seed disc fill check.

D101906132



D101906130



With vacuum hose connected and vacuum fan operating, remove vacuum cover and seed disc as an assembly. Inspect seed discs for proper seed fill.

See "Seed Metering System Troubleshooting" at the end of this section.

SEED METER OPERATION/MAINTENANCE

SEED METER DRIVE RELEASE

The seed meter drive is equipped with a clutch release mechanism that allows the drive to be disengaged from the seed metering unit for removal of the seed meter and mount or hopper. Disconnecting the drive allows the operator to check granular chemical application rates without dropping seed. It also allows the drive to one or more of the rows to be disconnected when finishing fields.

D011006101

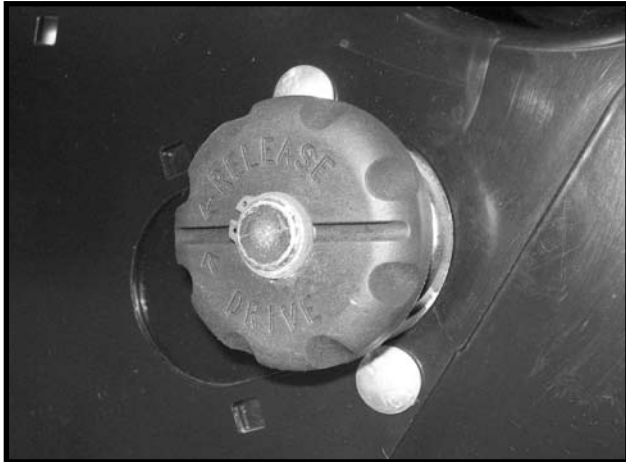

To disengage the drive, turn the knob $\frac{1}{4}$ turn counterclockwise. To engage the drive, turn the knob $\frac{1}{4}$ turn clockwise.

SEED METER OPERATION/MAINTENANCE

SEED METER MAINTENANCE

(METR71)

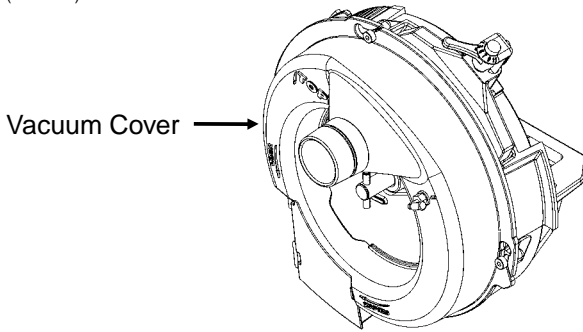

Clean, high quality seed should be used for maximum meter accuracy. Damaged or cracked seed, hulls or foreign material may become lodged in the seed disc orifices and greatly reduce meter accuracy.

It is suggested that the seed disc be inspected and cleaned daily, checking for any buildup of foreign material or any blocked orifices. Clean the seed disc by washing it with soap and water as needed. Dry thoroughly.

Inspect singulator brush for wear and replace if necessary following every 200 acres per row of operation.

The seed disc and/or vacuum cover should be replaced if abnormally high vacuum is required for consistent operation or if consistent operation can not be achieved. If adjustment of the singulator brush does not affect performance of the meter or if the brushes appear frayed, the singulator brush may need to be replaced. If the seed disc orifices are plugged frequently with seed remnants, the cleanout brush or cleanout brush with ball-type ejector (if applicable) may need to be replaced. High quality seed should be used to attain best performance.

(METR70)

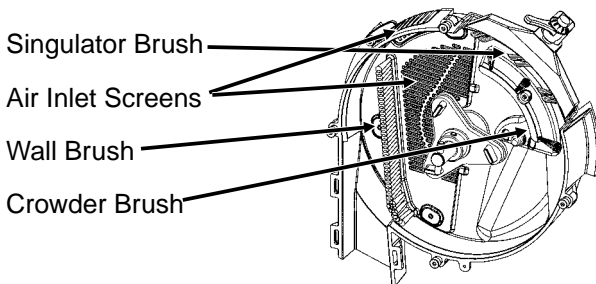

Prior to each planting season, inspect seed discs, singulator brush, crowder brush, wall brush and air inlet screens and clean or replace as needed.

See "Preparation For Storage" for additional EdgeVac® Seed Metering System maintenance.

IMPORTANT: Replace hopper lids after hoppers are filled to prevent accumulation of dust or dirt in the seed meter which will cause premature wear.

NOTE: Remove seed discs from meters for annual storage and store the seed discs vertically on a dowel or pipe.

VACUUM MANIFOLD MAINTENANCE

In the course of normal operation, dust will accumulate in manifolds and hoses. Manifolds should be cleaned annually. More frequent cleaning may be necessitated by abnormally dusty planting conditions.

Remove vacuum hose from each seed meter. Operate the vacuum fan at full hydraulic flow from the tractor for two minutes to clear manifolds, hoses and fittings of dust and debris.

SEED METER OPERATION/MAINTENANCE

SEED METERING SYSTEM TROUBLESHOOTING

PROBLEM	POSSIBLE CAUSE	SOLUTION
Low seed count.	Meter RPM too high.	Reduce planting rate or planting speed.
	Singulator brush setting too aggressive.	Adjust singulator brush.
	Vacuum level too low.	Increase fan speed.
	Seed sensor not picking up all seeds dropped.	Clean seed tube. Move meter to different row.
	Seeds sticking to seed disc.	Use graphite or talc to aid release.
	Seed treatment buildup in seed disc recesses.	Reduce amount of treatment used and or mix thoroughly. Add talc.
	Seed size too large for disc used.	Use appropriate disc for seed size.
	Wrong transmission setting.	Change transmission to desired rate.
	Wrong seed disc.	Use appropriate disc for seed type and size.
	Drive wheel slippage.	Compensate by adjusting transmission sprockets.
	Low tire pressure.	Adjust tire pressure to correct level.
	Failed/worn drive components.	Inspect and replace parts as required.
	Plugged orifices in seed disc.	Inspect and clean disc. Check cleanout brush. (If Applicable)
	Loss of vacuum at meter.	Check for foreign material between vacuum cover and disc. Inspect parts for wear/damage. Clean or replace as required.
	Seed bridging in hopper.	Add graphite to improve seed flow.
	Faulty vacuum gauge reading.	Repair/replace gauge.
	Dirt in vacuum manifold.	Check vacuum manifold for dirt and clean.
	Seed baffle (If Applicable) not allowing seed flow due to bridging of seed.	Thoroughly mix talc to coat all seeds. Remove seed baffle. See "Seed Meter" in Seed Meter Operation/Maintenance section.
	60 cell soybean disc not filling properly due to excessive RPM.	Replace with 120 cell soybean disc.
	Seed disc worn.	Replace.
Vacuum cover worn.	Replace.	
Not planting seed.	Seed hoppers empty.	Fill seed hopper.
	Seed tube plugged/damaged.	Clean or replace tube.
	Meter drive damaged.	Repair/replace drive components.
	Low/no vacuum.	Inspect vacuum system and repair as necessary.
	Singulator brush setting too aggressive.	Adjust singulator brush.
	Faulty vacuum gauge.	Repair/replace vacuum gauge.
	Seed bridging in hopper.	Add graphite to improve seed flow.
	Loss of vacuum at meter.	Check for foreign material between vacuum cover and disc. Inspect parts for wear/damage. Clean and/or replace as required.
	Wrong seed disc.	Use appropriate disc for seed type and size.
	Meter drive clutch not engaged.	Engage drive clutch.
	Fan not running.	Start fan.
	Dirt in vacuum manifold.	Check vacuum manifold for dirt and clean.

(Continued On Following Page)

SEED METER OPERATION/MAINTENANCE

SEED METERING SYSTEM TROUBLESHOOTING (Continued)

PROBLEM	POSSIBLE CAUSE	SOLUTION
Not planting seed. (Continued)	Seed baffle (If Applicable) not allowing seed flow due to bridging of seed.	Thoroughly mix talc to coat all seeds. Remove seed baffle. See "Seed Meter" in Seed Meter Operation/Maintenance section.
	60 cell soybean disc not filling properly due to excessive RPM.	Replace with 120 cell soybean disc.
High seed count.	Wrong transmission setting.	Change transmission to desired rate.
	High vacuum.	Adjust vacuum level to appropriate level.
	Wrong seed disc.	Replace seed disc.
	Singulator brush setting not aggressive enough.	Adjust singulator brush.
	Worn singulator brush.	Inspect brush and replace as required.
	Seed leaking past wall brush.	Inspect wall brush condition and installation. Replace as necessary.
	Faulty vacuum gauge.	Check gauge line for dirt/obstruction. Repair/replace vacuum gauge.
Poor seed spacing.	Obstruction in seed tube.	Clean seed tube.
	Dirty/damaged seed disc.	Inspect seed disc for damage, foreign material in orifices or seed treatment buildup in recesses. Clean or replace as required.
	Wrong vacuum setting.	Adjust vacuum to appropriate level.
	Excess foreign material in seed.	Inspect and clean meter and seed discs. Use clean, undamaged seed.
	Incorrect singulator brush setting.	Adjust singulator brush to appropriate setting.
	Inconsistent driveline.	Inspect drive components for rust, misalignment, worn or damaged parts. Replace/repair as required.
	Toolbar not level or wrong height.	Adjust hitch to level toolbar and row units.
	Planting too fast for conditions.	Reduce speed.
	Rough field conditions.	Reduce speed.
Irregular seed population.	Driving too fast.	Reduce speed.
	Drive wheels slipping.	Reduce speed. Decrease row unit down pressure spring settings.
Unable to achieve desired vacuum level.	Tractor hydraulic flow set too low.	Increase flow to fan motor.
	Incorrect hydraulic connections.	Check all hydraulic connections and hose routings.
	Damaged fan components.	Inspect motor and impeller for wear/damage and repair/replace as necessary.
	Vacuum hose pinched/kinked/ blocked.	Inspect air lines for any damage or obstruction. Clean air lines and manifold by removing end cap from manifold and running fan at high speed.
	Vacuum hose loose/disconnected.	Inspect and reattach all air hoses.
	Tractor not producing required hydraulic flow/pressure.	Have tractor serviced by qualified technician.
	Dirt in vacuum gauge line.	Check gauge line for dirt/obstruction and clean.

SDS SEED DELIVERY SYSTEM OPERATION

INTRODUCTION

The seed delivery system consists of two bulk seed hopper assemblies with drop hoses to direct seed to seed meters/mounts at each row unit. Each bulk seed hopper feeds half of the planter. The meter mounts replace the standard 1.9 bushel seed hoppers. The row units and seed meters are the same as used on other KINZE® planters.

(TWL281)

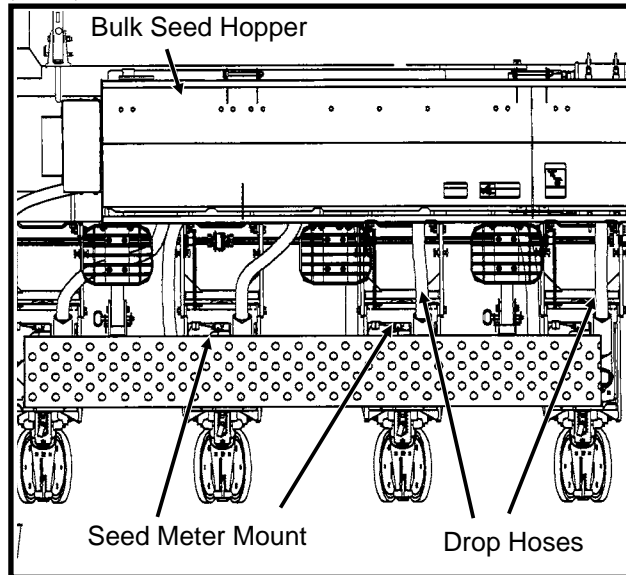

The seed delivery system is designed to evenly distribute seed to each row to assure all seed meters maintain a ready supply of seed. Seed placed in the bulk seed hopper is delivered to the outboard end of the hopper by a slow speed, bristle-tipped auger. An elevator system with 36 rubber-coated, 1/4 cup capacity buckets delivers the seed to the brush auger located in the distribution manifold at the top of the bulk seed hopper. Drop collars attached to the distribution manifold direct seed through a drop hose to a seed meter/mount on each row unit. At initial fill, as one meter and drop hose is filled to capacity the auger inside the distribution manifold carries seed on to the next row until all active row outlets are filled to capacity.

D021102218

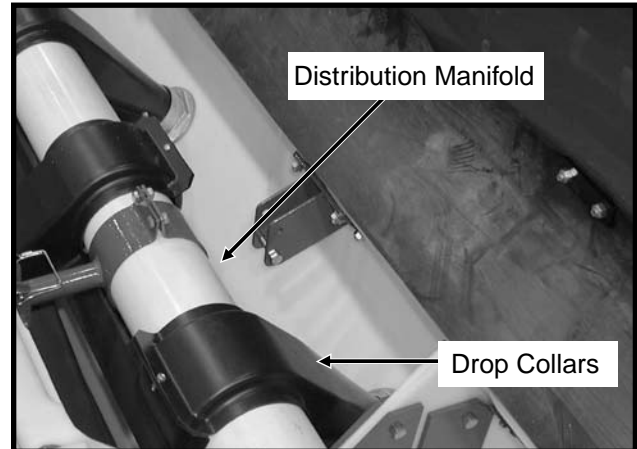

NOTE: After all row outlets are filled to capacity, seed will continue to be evenly distributed to all rows until the bulk seed hopper is empty. When the bulk seed hopper is empty or the auger system is shut off, all drop hoses will “plant out” equally and all rows should run out of seed at approximately the same time.

CAPACITIES

Hopper capacity is approximately 55 bushels for the 12 Row 30" planter and 85 bushels for the 16 Row 30" planter.

Each drop hose/seed meter/mount combination has a capacity of 12 pounds of seed. Example: At 12 pounds per row, a 50 pound bag of soybeans will fill 4 rows. It will take 4 bags (2 per bulk seed hopper) of seed to charge all rows on a 16 row planter or 8 bags (4 per bulk seed hopper) to charge all rows on an Interplant® Package equipped 16 row planter (31 or 32 rows).

When planting seed variety plots, it may be desirable to fill seed meters using the access hole provided on each meter mount.

SDS SEED DELIVERY SYSTEM OPERATION

SEED DISTRIBUTION MANIFOLD

A handle and lock pin located inside each bulk seed hopper allows the seed distribution manifold to be rotated to direct seed to front and rear rows or to rear rows only. When the handle is pointing to the rear, seed flows to the rear rows only as the manifold is rotated to close off seed from the forward pointing drop collars. When the handle is pointing toward the front, seed flows to the front and rear rows equally as all outlets are enabled.

D021102218

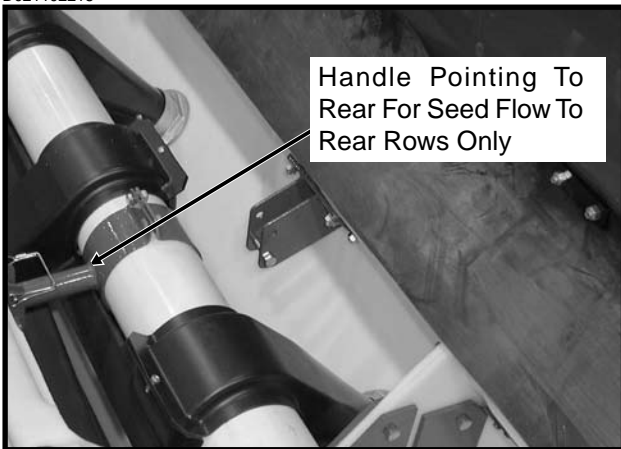

OVERFLOW

An overflow is provided so seed not used to charge drop hoses/seed meters/mounts, can return to the seed reservoir to be picked up by the horizontal floor auger and recirculated through the system.

D021102222

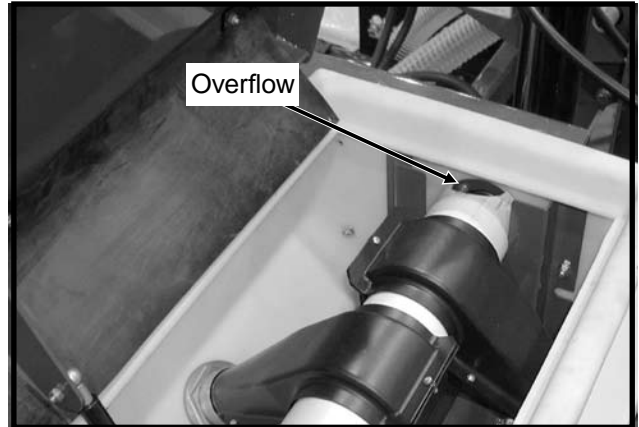

SDS SEED DELIVERY SYSTEM OPERATION

SEED METER MOUNT LATCH

Due to the pull exerted by the drop hose on the seed meter/mount as the row unit moves up and down, a pin is provided to secure the seed meter mount latch.

DD011006200

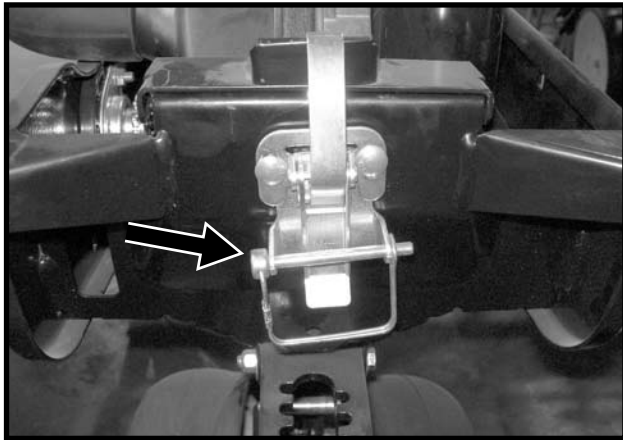

HYDRAULIC SYSTEM

D071603219

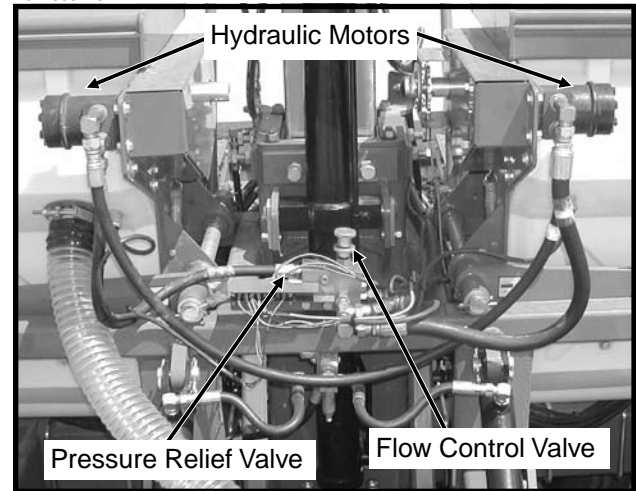

The hydraulic system includes two centrally-mounted hydraulic motors plumbed in series, a pressure relief valve, a check valve and an adjustable flow control valve. The flow control allows auger speed to be varied to meet seed demand.

The hydraulic system operates from one selective control valve. A separate (fourth) remote SCV is required on the tractor, in addition to the three remotes required to operate the (a) lift, (b) row marker/rotate functions and (c) vacuum fan motor circuits.

If the tractor has a motor return circuit, its use will allow the system to work with reduced back pressure and reduced heat generation, but is not required for the proper operation of the system.

If the tractor has cab mounted flow controls, open the needle type flow control on the planter and use the flow control valve on the tractor to adjust auger speed. Adjust accordingly. See "Auger Speed Adjustment" and the tractor's operators manual.

The hydraulic motor circuit will use 1.5 to 4.0 gallons per minute (GPM) at 700 PSI to operate a fully loaded seed delivery system.

An in-line check valve in the return line prevents reverse operation of the auger system.

IMPORTANT: The proper auger speed when planting is critical. Excess auger speed will cause more seed than necessary to be drawn into the system which may cause wear on mechanical components and potential damage to the seed.

SDS SEED DELIVERY SYSTEM OPERATION

AUGER SPEED ADJUSTMENT

Auger speed should be adjusted to deliver seed to the row units at a rate equal to the planting rate. This keeps all the drop hoses, meter mounts and seed meters filled equally but will not cause seed to be recirculated through the system excessively.

D071603219

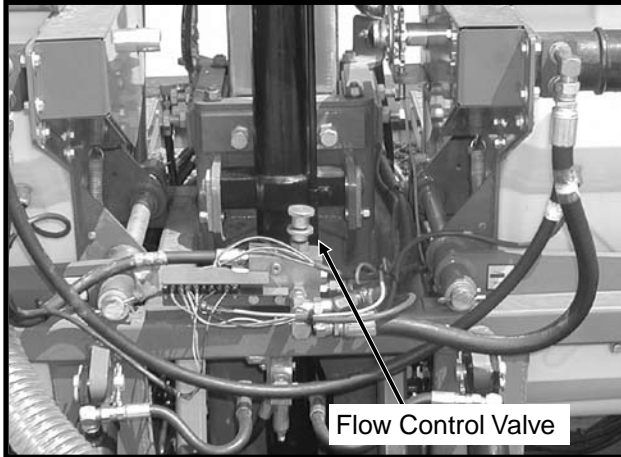

SDS auger speed should be controlled using the tractor's flow control (SVC). Set the flow control valve, on the SDS valve block located on the front center frame of the planter, at full flow. To adjust auger speed when the tractor does not have a responsive flow control valve, loosen the jam nut on the flow control valve on the SDS valve block and turn the control clockwise, or IN, to decrease auger speed and counterclockwise, or OUT, to increase auger speed. When adjusting auger speed using the flow control valve on the SDS valve block, check to be sure adequate oil is supplied to all planter functions to avoid motor damage. To prevent catastrophic failure, it is essential to ensure adequate oil flow to the vacuum fan hydraulic motor.

IMPORTANT: The proper auger speed when planting is critical. Excess auger speed will cause more seed than necessary to be drawn into the system which may cause wear on mechanical components or increase the potential for damage to the seed.

When set correctly, the system will keep all meters and hoses full with minimum overflow out of the top auger. The fine tuning of the auger speeds can be accomplished by slowing the auger speed until the system is starved, indicated by a center row running low on seed. Adjust auger RPM upward to keep up with planting rate.

It is suggested that the top distribution manifold auger speed be set at 20 to 25 RPM for planting seeds such as corn and 80 to 100 RPM for planting seeds such as soybeans. These speeds are approximate depending on row size of planter, and planting speed and population.

A rotation indicator is provided on the upper inboard end of each bulk seed hopper that allows the operator to monitor shaft rotation.

D071603219

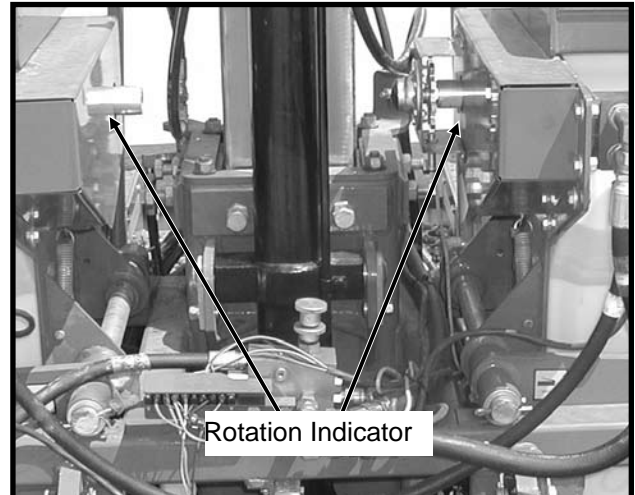

SDS SEED DELIVERY SYSTEM OPERATION

BULK SEED HOPPER MONITOR

(A10189c)

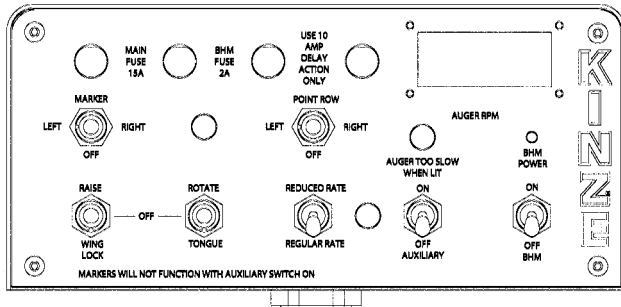

The bulk seed hopper monitor system consists of a speed sensor, which is located over the rotation indicator on the L.H. bulk seed hopper; and two seed flow sensor assemblies. One sensor is installed in each bulk seed hopper in the inner-most pull row unit drop funnel.

The bulk seed hopper monitor system is powered by the tractor battery (requires 12 volts DC). If connected to the convenience outlet provided on the tractor, the bulk seed hopper monitor system powers down when the tractor is powered down. If the system is wired directly to the tractor battery, use the push button switch on the back of the console to turn the console backlight off and the toggle switch in the lower R.H. corner to power off the console.

D121802102



Auger Speed Sensor

The planter control console displays auger RPM to assist in fine tuning and monitoring the auger speed.

A warning light, incorporating a 100 second delay, turns ON when no seed flow is sensed in either drop funnel in which the sensors are installed.

See "Auger Speed Adjustment" and "Operation" for additional information.

D121802116

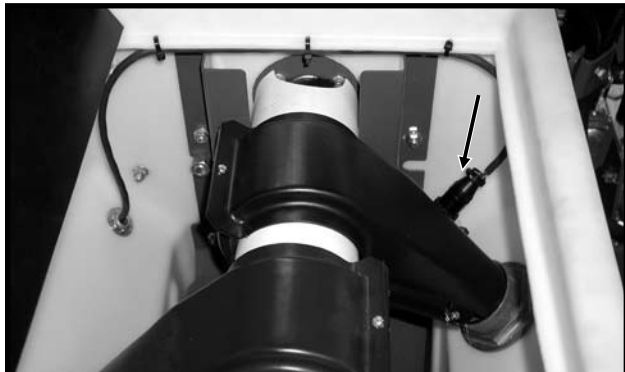

Seed Flow Sensor

SDS SEED DELIVERY SYSTEM OPERATION

FILLING

Use clean seed and make certain there are no foreign objects in the hopper. Always close hopper lids during field operation to prevent the accumulation of dust or dirt in the seed meters which will cause premature wear.



CAUTION: Be sure all shields and covers are in place before operating system.

When filling an empty planter, it is recommended that the auger system be operated so the drop hoses will begin to fill as seed is loaded into the bulk seed hoppers. Open the flow control valve so the top distribution manifold auger (system speed) turns at 100 to 150 RPM for faster filling. Fill the bulk seed hoppers with the desired amount of seed. When all drop hoses are filled, shut off the system and return the flow control to its planting operation setting. See “Auger Speed Adjustment”.

NOTE: Maximum system speed is 150 RPM.

D071603219

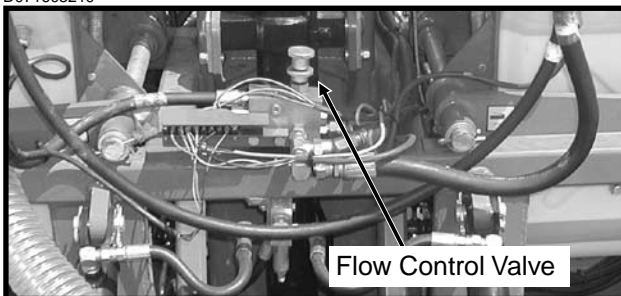

When all drop hoses are filled, seed can be placed in any location in the bulk seed hopper and it will be distributed evenly to all rows.

When starting a new system, switching to a different type of seed (i.e. corn to soybeans) or using an unfamiliar type of seed treatment, it is very important to test the operation of the system with a small amount of seed before completely filling the bulk seed hoppers.

D021102222

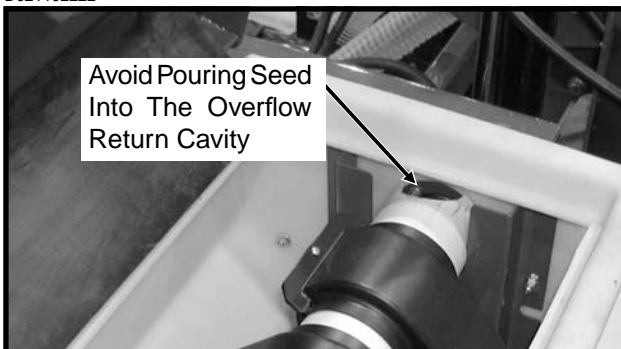

pouring seed into the overflow return cavity.

SEED LUBRICATION

The use of powdered graphite is recommended. In addition to the benefits graphite provides the seed meters, graphite will also aid seed flow through the seed delivery system. If seed treatments or inoculants that add moisture to the seed are used, talc is recommended along with the graphite. Be sure to test unfamiliar combinations before completely filling the system. Apply any seed treatments, graphite and/or talc alternately in layers with the seed while filling the bulk seed hopper. The auger system will mix the seed, seed treatments, graphite and/or talc, so pre-mixing may not be as critical as with planters equipped with individual seed hoppers.

As new seed is added to the bulk seed hopper, and seed from a previous fill is still present, some mixing will occur. Generally the seed in the bulk seed hopper closest to the inboard end of the hopper will be planted first before the seed is circulated through the auger lift system. Be certain this seed is treated as it would not have had a chance to mix with the seed treatments, graphite and/or talc.

82354-1e



See “Seed Meter” in the Row Unit Operation section for additional information.

SDS SEED DELIVERY SYSTEM OPERATION

OPERATION

After seed is distributed to all rows, adjust the speed of the auger hydraulic motors as necessary to maintain an adequate supply of seed without excessive seed movement. Elevator chain speed is preset to deliver seed at proper amount to feed the upper auger and is not adjustable. The tension on the elevator chain must be maintained correctly. See "Bulk Seed Hopper Elevator Chain Adjustment" in the Maintenance section. See "Row Unit Operation" section for operation of seed meters and various row unit optional equipment.

Seed will be delivered equally to all rows until the bulk seed hopper supplying those rows is empty. When the bulk seed hopper is empty, the drop hoses and seed meters/mounts will each contain approximately 12 pounds of seed. This information can be used to determine the area that can be planted as the system empties.

EXAMPLE: Planting population is 32,000 seeds/acre. You are planting corn that weighs 50 pounds per 80,000 kernels. 12 pounds of seed in drop hoses/seed meters/mounts will equal approximately 19,200 seeds. This will be enough seed to plant 0.6 acres per row (7.2 acres with a 12 Row 30" planter or 9.6 acres with a 16 Row 30" planter).

See "Checking Seed Population" in Machine Operation section for additional information.

The planting range can be tested by filling the entire system, turning off the auger drive and planting until the drop hoses/seed meters are empty. Trial runs like this will give you a good idea as to how much seed to place in the bulk seed hoppers at the end of the planting season or when planning to switch varieties of seed, etc.

Many factors affect the seed demand rate including planter operating speed, population rate, number of rows, length of rows and size of seed. The suggested method when starting the season is to fill the system and then observe the seed level in the drop hoses during planting passes. Increase or decrease the auger speed as necessary to maintain a constant supply of seed to the meters.

The system is designed to run continuously and will not plug if allowed to operate without planting. If left running continuously for an extended period of time (15-20 minutes) with no planting activity, the overflow return cavity on the inboard end of the bulk seed hopper will fill with seed and seed will begin to boil out to the top of the overflow. This excess seed will fall back into the main part of the bulk seed hopper. No damage to the auger system will occur.

NOTE: If the system is operated for an excessive period without planting activity, and depending on how much seed is in the bulk seed hopper around the overflow return, seed falling back into the main bulk seed hopper could eventually collect under the lid, push the lid upward and overflow onto the ground.

NOTE: Avoid allowing the system to run continuously when no seed is being planted as seed will recirculate through the auger system multiple times and seed damage may occur.

SDS SEED DELIVERY SYSTEM OPERATION

CLEANOUT

Periodically empty the bulk seed hoppers completely to remove any foreign objects and to ensure proper seed meter operation.

When changing seed varieties or switching crops, a small amount of seed and fines will remain in the lower trough area of the bulk seed hoppers. To clean, remove the screen in the lower auger transfer area at the outer end of each bulk seed hopper. Starting at the center of the planter, hydraulically operate the auger system while using compressed air or a leaf blower to move remaining seed/fines toward the discharge hole.



WARNING: Always keep hands, feet and clothing away from moving parts. Do not wear loose-fitting clothing which may catch in moving parts.

(TWL262)

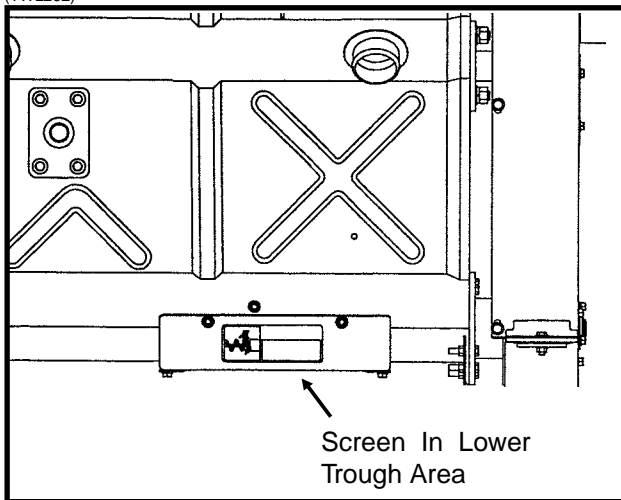

A small amount of seed may be left in the seed meters/mounts. Empty these by removing the seed meters/mounts and removing meter vacuum covers and seed discs or by vacuuming the remaining seed out.

D011006201

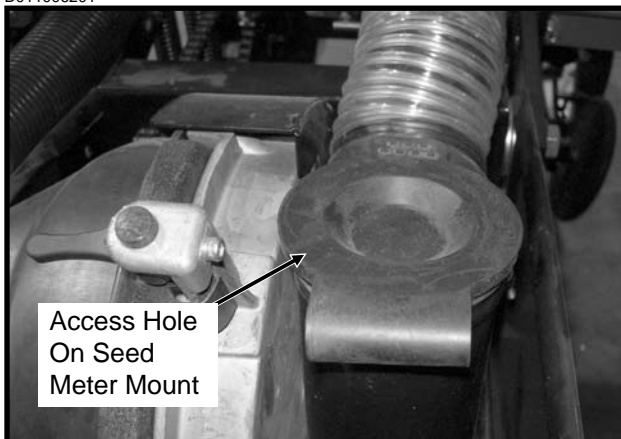

BULK SEED HOPPER COVERS

D021102229a



NOTE: The bulk seed hoppers are not water tight. Store the planter inside when possible. Fitted covers, for use if the planter must be stored outside, are available from KINZE® Repair Parts. Secure covers using grommets in covers and customer-supplied rubber tarp straps as needed.

ROW UNIT OPERATION

PLANTING DEPTH

Planting depth is maintained by the row unit gauge wheels. To increase or decrease the planting depth, first raise the planter to remove weight from the wheels. Then push down on the depth adjustment handle and reposition it forward to decrease depth or rearward to increase planting depth. Adjust all units to the same setting initially. Then lower the planter and check operation and planting depth of all row units. It may be necessary to readjust some rows to obtain uniform operation. Available depth adjustment range is approximately 1/2" to 3 1/2".



WARNING: Never work under the planter while in raised position without using safety lockup devices.

D020705102

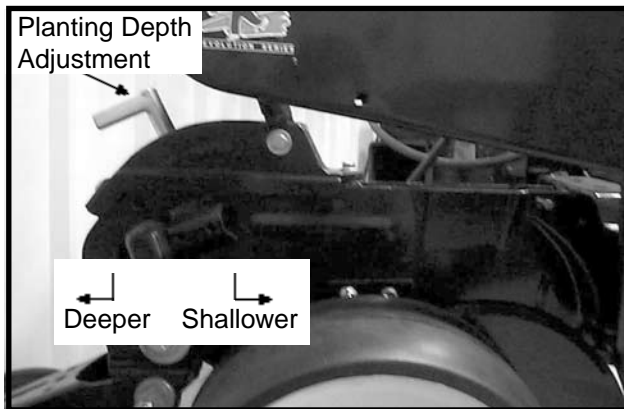

"V" CLOSING WHEEL ADJUSTMENT (Rubber And Cast Iron)



WARNING: Raise planter and install safety lockup devices before making closing wheel adjustments.

After adjusting planting depth, check the operation of the "V" closing wheels. The "V" closing wheels should have enough down pressure to close the seed trench and ensure good soil to seed contact. To increase spring pressure on the closing wheels, move the 5-position quick adjustable down force lever located on the top of the closing wheel arm to the rear. Moving the lever forward decreases spring tension.

Adjust all row units to a similar setting.

LF212299-15

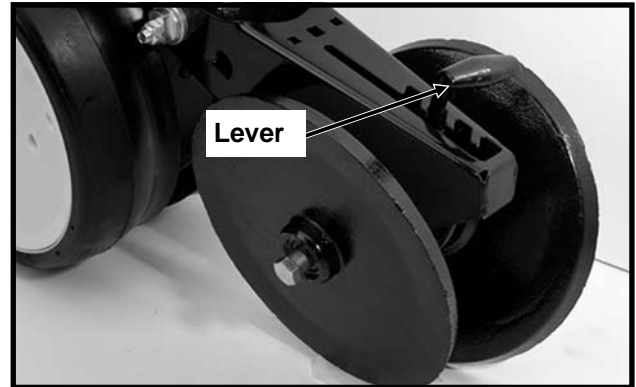

Light soil usually requires less down force at average depth (approximately 2") while heavy soil requires increased down force.

Eccentric bushings in the wheel arm stop allow for lateral adjustment of the "V" closing wheel assembly. Using a 3/4" wrench, loosen the hardware which attaches the closing wheel arm to the wheel arm stop. Using another 3/4" wrench turn the eccentric bushings until the **closing wheels are aligned with the seed trench**. Tighten hardware.

LF2122299-15

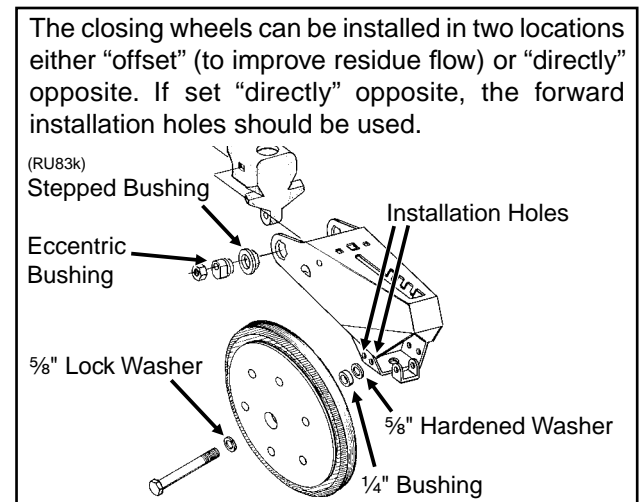
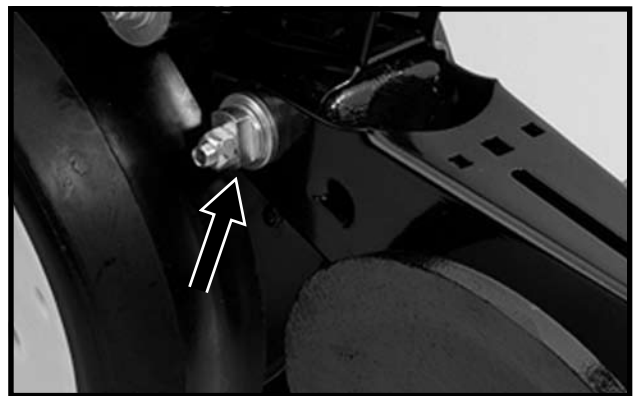

ROW UNIT OPERATION

CLOSING WHEEL SHIELD (Rubber And Cast Iron “V” Closing Wheels)

D11090208a

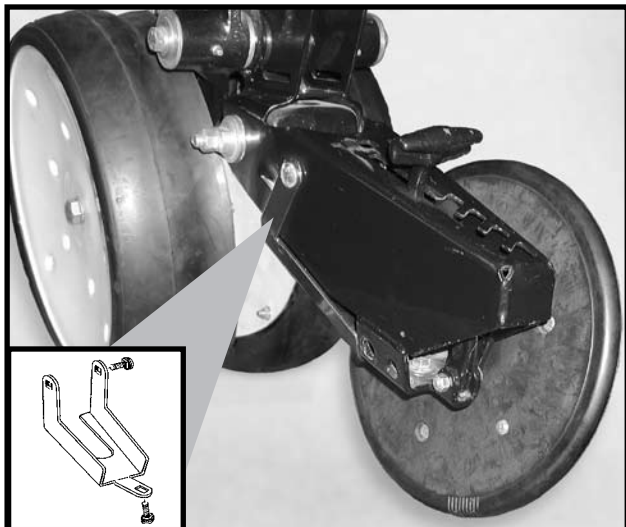

Shown With Closing Wheel Removed For Visual Clarity

The optional closing wheel shield is designed to be installed onto the underside of the closing wheel arm to help prevent root balls and stalks from plugging the closing wheels.

SEED HOPPER (Conventional Seed Hopper)

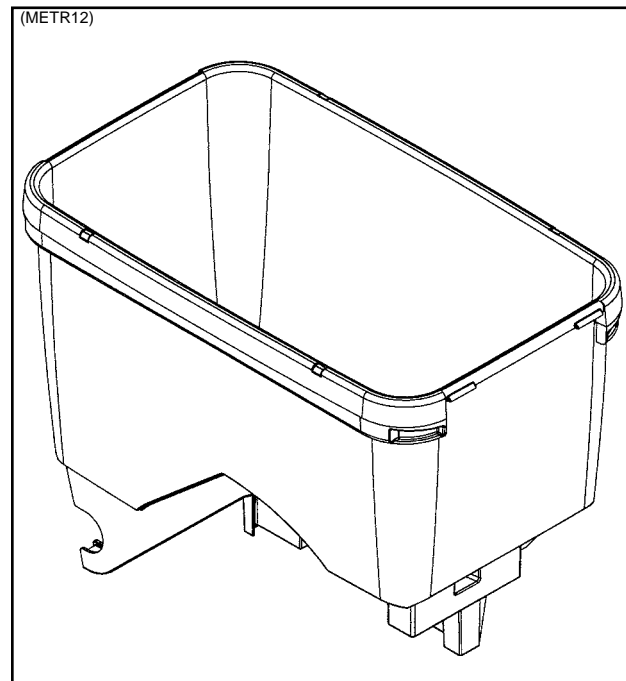

Seed hopper capacity is 1.75 bushels.

When filling the seed hopper use clean seed and make certain there are no foreign objects in the hopper. **Replace hopper lids after hoppers are filled to prevent the accumulation of dust or dirt in the seed meter which will cause premature wear.** See “Seed Meter” in Seed Meter Operation/Maintenance section.

Periodically empty the hoppers completely to remove any foreign objects and to ensure proper seed meter operation. To empty hopper, disengage meter drive and hopper latch and lift hopper off the hopper support. Disassemble vacuum cover and remove seed disc. Allow all seed to exit meter and inspect for complete cleanout. See “Seed Meter Drive Release” in Seed Meter Operation/Maintenance section.

ROW UNIT OPERATION

ROW UNIT CHAIN ROUTING

For proper operation and to minimize wear, the row unit drive chains must be properly tensioned and aligned.

Inspect and replace weak, worn or broken springs and and/or idlers and idler bushings.

NOTE: When idler shows signs of wear, it can be reversed for prolonged use.

D09280611a(RU80g)

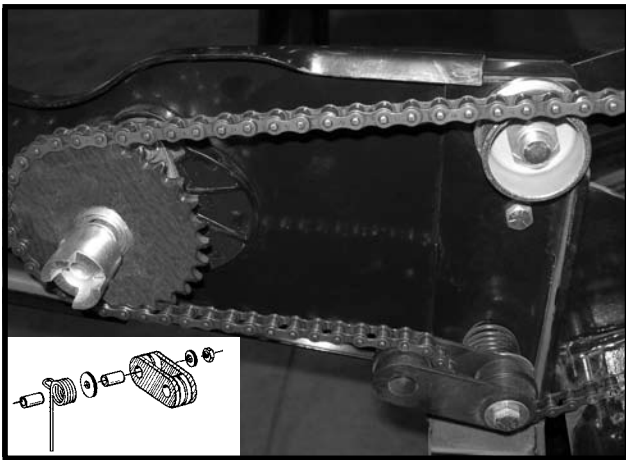

Pull Row Unit Meter Drive

D09280603a(RU80g)

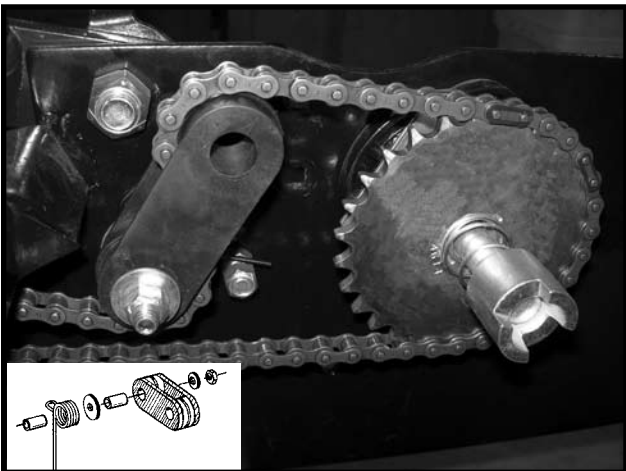

Push Row Unit Meter Drive

D051705102

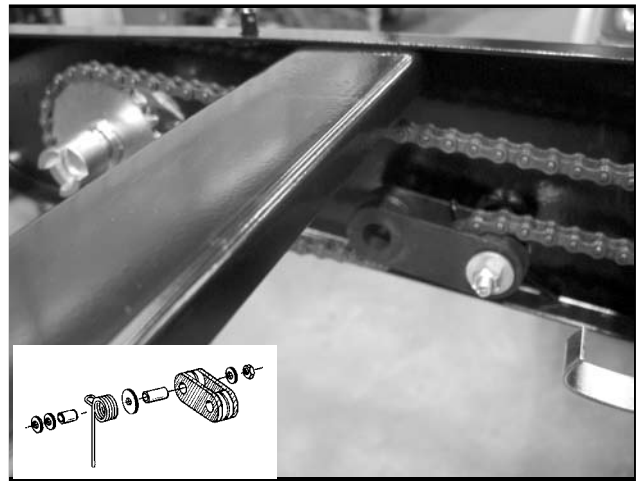

Row Unit Granular Chemical Drive

NOTE: Make sure connector link is installed with closed end oriented properly as shown below.

(PLTR24)



ROW UNIT OPERATION

QUICK ADJUSTABLE DOWN FORCE SPRINGS

Quick adjustable down force springs are designed to increase penetration in hard soil and keep the row unit from bouncing in rough field conditions.

Two springs per row, one on the L.H. parallel arms and one on the R.H. parallel arms, are used unless equipped with row unit mounted no till coulters. Four springs per row are used with row unit mounted no till coulters.

D06300305

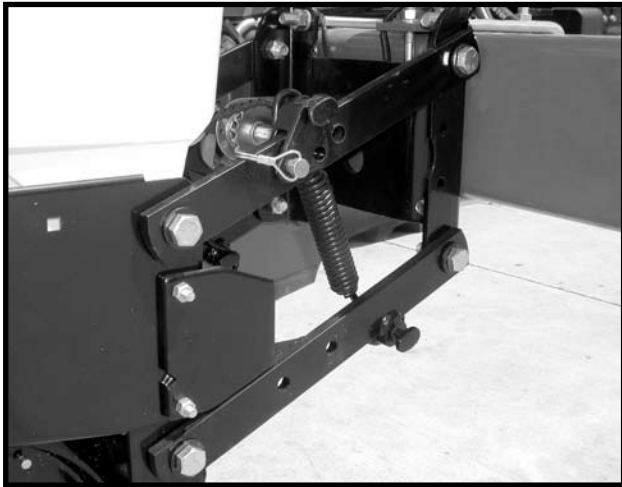

Two Springs Per Row (Dual)

D07010301



Four Springs Per Row (Quad)
(Used Only In Conjunction With Row Unit Mounted No Till Coulters)

NOTE: Four springs per row are to be used with row unit mounted no till coulters only.

There are four positions for spring tension adjustment. Position 1 allows for minimum down pressure and position 4 for maximum down pressure.

L0096(PLTR27e)

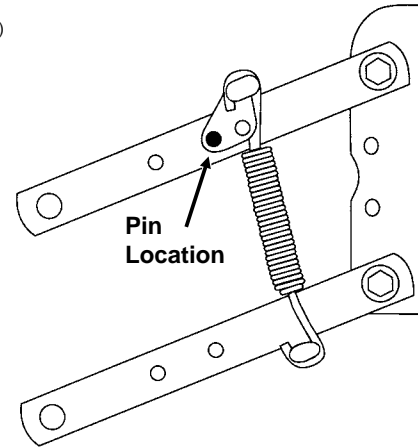

Position 1 (Minimum)

(PLTR28e)

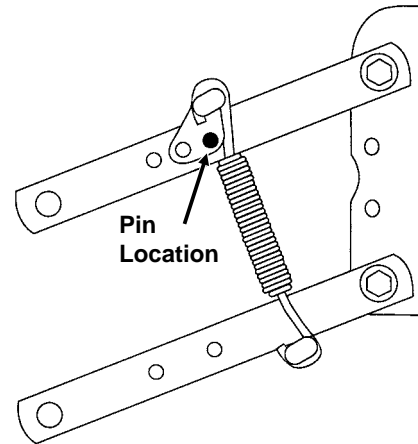

Position 2

(PLTR29e)

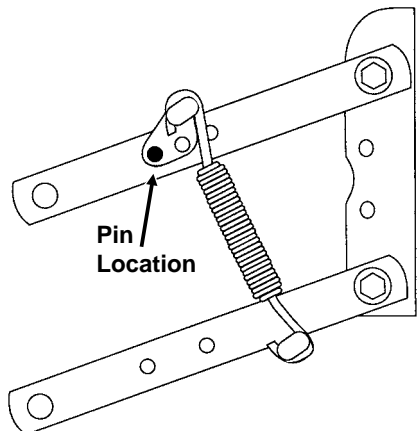

Position 3

(Continued On Following Page)

ROW UNIT OPERATION

(PLTR30e)

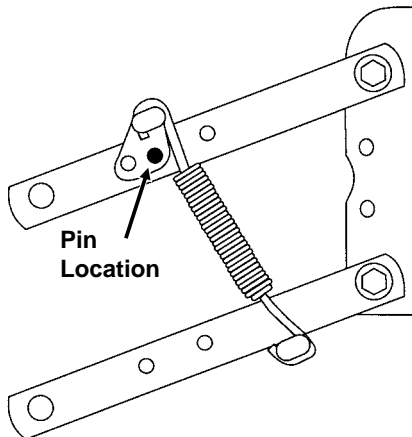

Position 4 (Maximum)

To adjust spring tension, raise planter and remove spring mount pin at top of spring. Slide mount to desired position and install pin.

NOTE: It is necessary for the operator to adjust springs according to field conditions. If springs are adjusted for too much down pressure for field conditions, it is possible for the row units to lift the planter to the extent that the drive wheels do not make sufficient contact. Too much down pressure in soft field conditions can cause the row unit to run too deep.



WARNING: Always install safety lockup devices or lower machine to the ground before working under or around the machine.

IMPORTANT: Springs must always be installed with open side of spring hooks toward seed meter mounts or seed hoppers to prevent binding on spring mount adjustment pins.

ROW UNIT OPERATION

FRAME MOUNTED COULTER

LF083002101

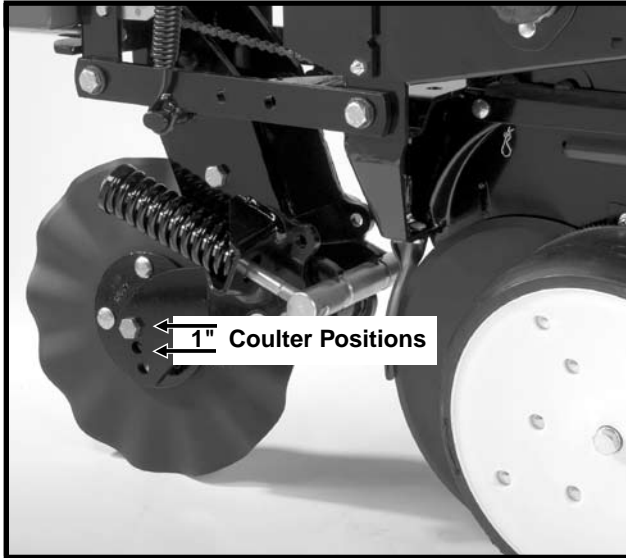

Frame mounted coulters with 1" bubbled, 1" fluted (8 flutes) or 3/4" fluted (13 flutes) blades may be used on pull row units only. (Not compatible with push row units.)

The frame mounted coulters is designed to apply necessary spring down pressure on the coulters for maximum penetration while exerting less shock load on the row unit.

The initial location of the coulters blade is in the top hole. The blade can be relocated to one of the lower two holes (1" increments) as wear occurs or if deeper operation of the blade is desired.

LF083002101

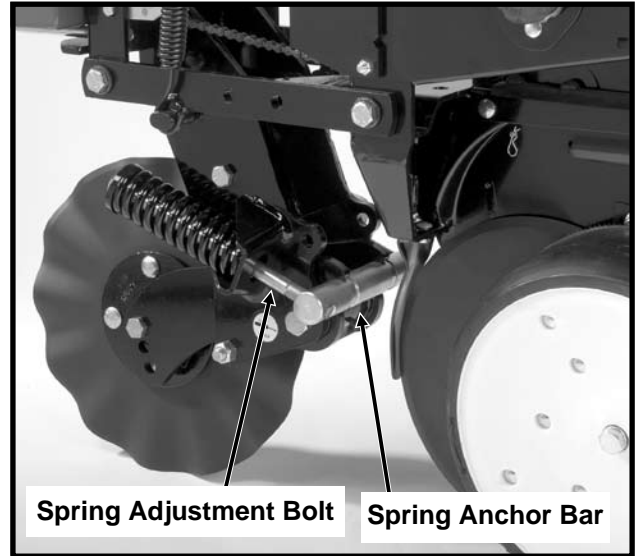

DOWN PRESSURE ADJUSTMENT

Down force adjustment is made by tightening or loosening the two spring adjustment bolts. With the planter in raised position, turn the bolts clockwise to increase down pressure or counterclockwise to decrease down force. Set both springs the same.

Down force on the blade is shown below in lbs.

End Of Spring Adjustment Bolt Flush With Spring Anchor Bar (Shown Above)	End Of Spring Adjustment Bolt Extended 1/2" Through Spring Anchor Bar	All Threads Used (Maximum)
275 lbs.	400 lbs.	500 lbs.

NOTE: Avoid setting down pressure higher than is required for consistent soil penetration. Excessive pressure will increase the chances of damage to coulters components when the coulters strikes an obstacle.

ROW UNIT OPERATION

RESIDUE WHEELS (For Use With Frame Mounted Coulter)

The residue wheels for use with the frame mounted coulter may be used on pull row units only.

LF083002102



The residue wheels are attached to the frame mounted coulter with two cap screws and sleeves allowing the unit to free-float. A 2-position spindle bolt mounting allows the tined wheels to be mounted interlocked or staggered. Depth adjustment is made using a spring-loaded cam and pin with 11 positions in 1/4" increments. A high point on the cam allows the wheels to be locked up so they do not contact the ground. A weed guard, located on the inboard side of each wheel, aids in the prevention of weed wrap which can cause premature bearing failure.

(RU135l)

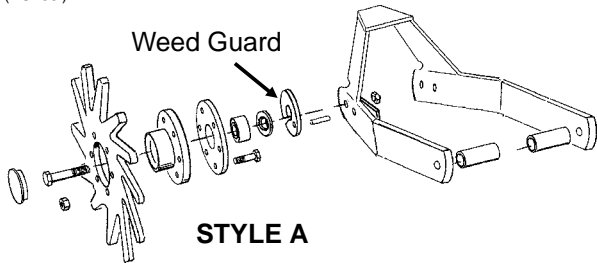

(RU135m)

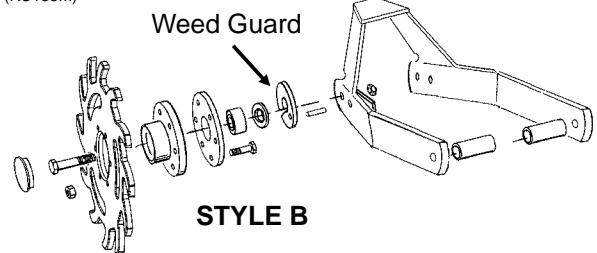

NOTE: Opening in weed guard must point down.

ROW UNIT MOUNTED DISC FURROWER

The row unit mounted disc furrower is for use on pull row units only (not compatible with Interplant® push row units). The disc furrower may be equipped with either 12" solid blades or 12" notched blades.

Disc furrowers are used to clear crop residue, dirt clods and dry soil from in front of the row units for a clean and smooth seed bed. Notched blades are used for heavier residue conditions. The notched blades cut crop residue and move it aside to prevent plugging or pushing.

LF212299-22

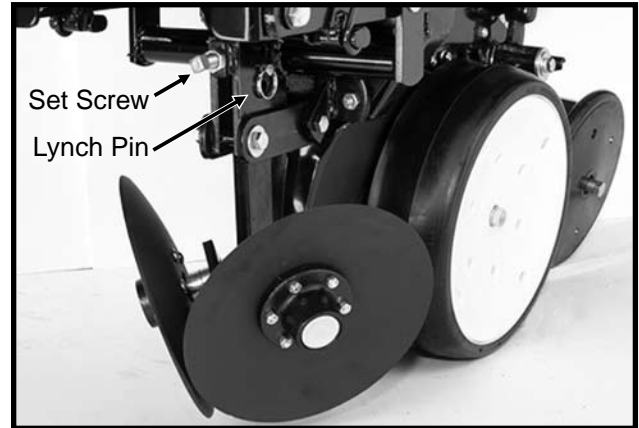

Vertical adjustment in 1/3" increments is possible by removing the lynch pin which secures the vertical support arm and moving the support arm up or down as required. Reinstall lynch pin. Finer adjustment can be attained by removing the lynch pin and using the 5/8" x 2 1/4" set screw to clamp the support arm in the required position.

(RU98e)

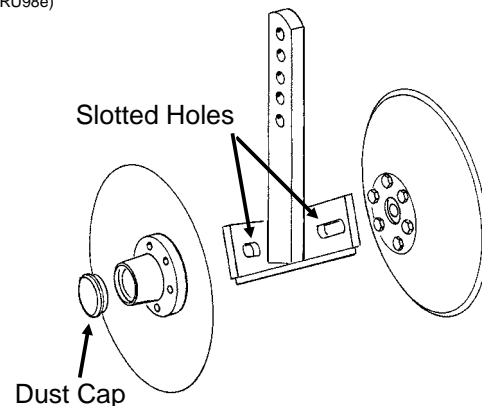

Slotted holes in the support arm where the blades are mounted allow fore and aft adjustment of the disc blades. Blades can be adjusted so the front edges meet or one blade can be moved to the rear and the other to the front of the slot so the cutting edge of one blade overlaps the edge of the other blade. The dust cap must be removed to make these adjustments.

ROW UNIT OPERATION

ROW UNIT MOUNTED RESIDUE WHEEL

The row unit mounted residue wheel may be used on pull row units and push row units.

D101701113



STYLE A

(A12685)

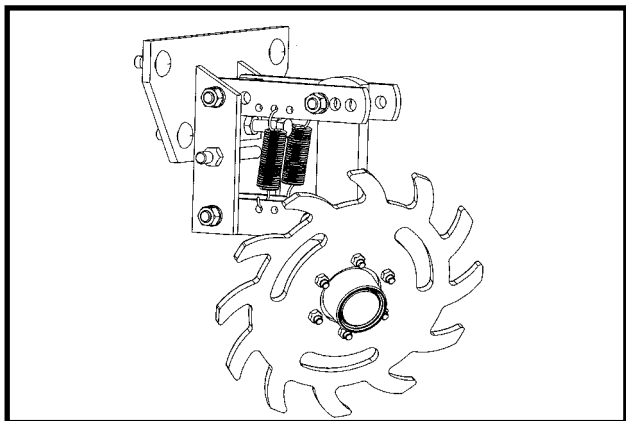

STYLE B

Two adjustable springs on the parallel links on each residue wheel allow for down force adjustment. Position 1 as shown at right provides minimum down pressure and position 3 maximum down pressure.

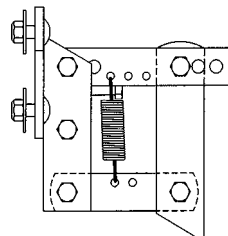

Position 1 (*Minimum*) (PLTR31a)

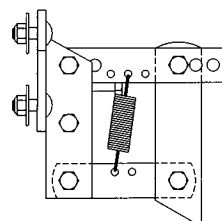

Position 2 (PLTR32a)

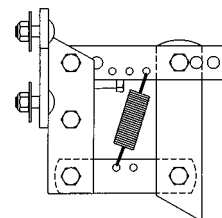

Position 3 (*Maximum*) (PLTR33a)

For additional uplift or float, position springs as shown below.

(PLTR34a)

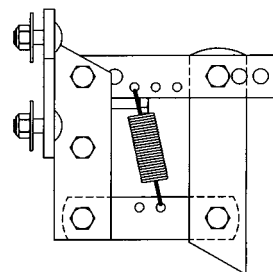

To adjust down force springs, raise the row unit out of the ground and reposition springs as shown for the desired down pressure.

ROW UNIT OPERATION

D101701112



A full threaded bolt and jam nut located on the upper link allows maximum depth to be set for loose soil conditions. Initial setting should be 1 3/4" above the depth of the row unit double disc opener.

Three holes in the upper link allow for wheel angle adjustment. With the wheel mount in the most vertical position, using the rear hole in the upper link, the residue wheel is most aggressive. Moving the wheel mount to one of the forward holes reduces the aggressiveness of the wheel for use in mulch till applications where the soil is loose.

D101701202

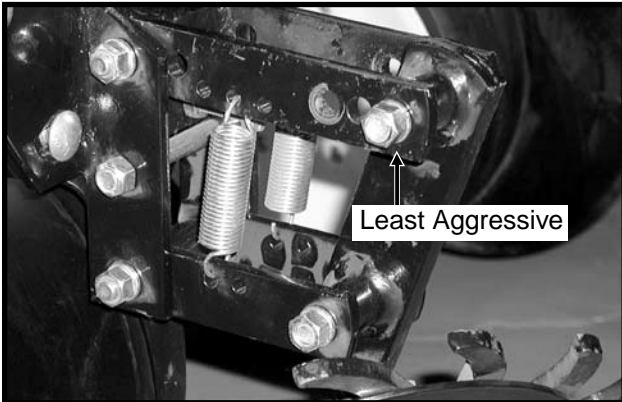

To lock the residue wheel up out of the ground, remove the 1/2" x 5" lockup bolt, raise the residue wheel and install bolt.

D011701203

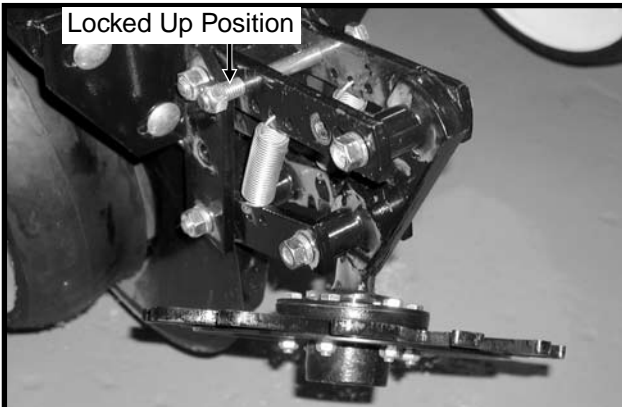

ROW UNIT OPERATION

ROW UNIT MOUNTED NO TILL COULTER

LF212299-19a

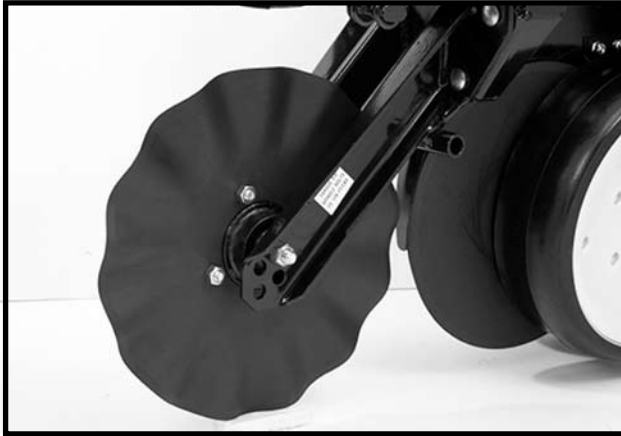

STYLE A (Two Sleeves For Installing Coulters Mounted Residue Wheels)

D05170706a



STYLE B (One Sleeve For Installing Coulters Mounted Residue Wheels)

Row unit mounted no till coulters with 1" bubbled, 1" fluted (8 flutes) or 3/4" fluted (13 flutes) blades may be used on pull row units and push row units. (3/4" fluted shown)

Four quick adjustable down force springs are required per row when using row unit mounted no till coulters. See "Quick Adjustable Down Force Springs".

For proper operation, the coulters should be aligned in relation to the row unit double disc openers. The coulters assembly can be adjusted by loosening the four attaching bolts, moving coulters arm to align and tightening the four attaching bolts.

The coulters blade can be adjusted to one of four 1/2" incremental settings in the forked arm. Initial location of the coulters is in the top hole. As the coulters blade wears, the blade should be adjusted downward to one of the three lower settings to maintain the coulters blade at or slightly below the opener discs. In very hard soil conditions such as compacted wheel tracks, opener penetration and cutting of surface residue may be improved by adjusting the coulters to operate below the depth of the double disc opener blades.

Operating depth can be checked by setting the planter down on a level concrete floor and checking the relationship between the coulters blade and row unit opener blade. Make sure the planter is level and coulters is square with the planter frame and aligned with the row unit disc opener.

NOTE: Torque 5/8" spindle hardware to 120 ft. lbs.

ROW UNIT OPERATION

COULTER MOUNTED RESIDUE WHEELS

LF212299-23



STYLE A - Used With Style A Row Unit Mounted No Till Coultter

D05170708a

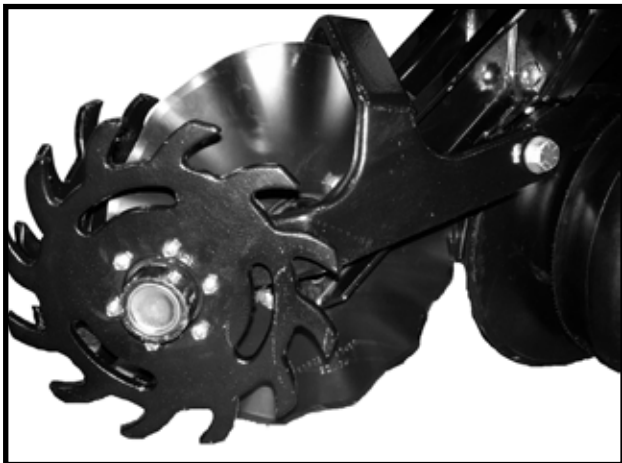

STYLE B - Used With Style B Row Unit Mounted No Till Coultter

Coultter mounted residue wheels are designed for use on pull row units and push row units. Row unit extension brackets are required on the four center pull row units if the planter is equipped with coultter mounted residue wheels.

The coultter mounted residue wheels are attached to the row unit mounted no till coultter with one cap screw and sleeve allowing the unit to free-float. A 2-position spindle bolt mounting allows the tined wheels to be mounted interlocked or staggered. A lock nut on the inside of the mount locks the spindle cap screw. Depth adjustment is made using a spring-loaded cam and pin with 11 positions in 1/4" increments. A high point on the cam allows the wheels to be locked up so they do not contact the ground. A weed guard, located on the inboard side of each wheel, aids in the prevention of weed wrap which can cause premature bearing failure.

(RU104tt)

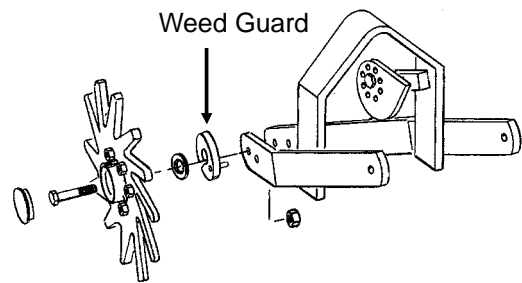

STYLE A

(RU153a)

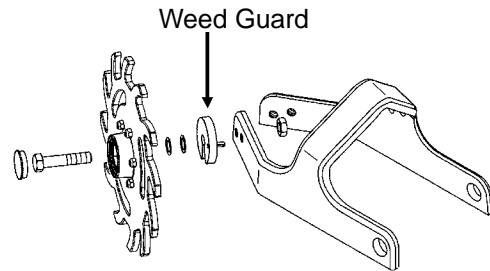

STYLE B

NOTE: Opening in weed guard must point down.

ROW UNIT OPERATION

GRANULAR CHEMICAL HOPPER AND DRIVE

LF212299-6



The granular chemical hopper has a 1.4 cubic feet capacity.

Be sure no foreign objects get into the hopper when it is being filled. Replace the hopper lids after filling the hoppers to prevent the accumulation of dirt and moisture.

The metering gate located on the bottom of the hopper regulates the application rate. See "Dry Insecticide And Dry Herbicide Application Rate Charts" in this manual. Calibrate using the chemical manufacturers' instructions.



WARNING: Agricultural chemicals can be dangerous. Improper selection or use can seriously injure persons, animals, plants, soil or other property. BE SAFE: Select the right chemical for the job. Handle it with care. Follow the instructions on the container label and of the equipment manufacturer.

The granular chemical clutch drive coupler and meter shaft can be disengaged and engaged by turning the throwout knob located at the rear of the hopper support panel. To engage the drive, turn the knob ¼ turn clockwise. To disengage the drive, turn the knob ¼ turn counterclockwise. Slotted holes in the hopper support panel and clutch housing allow for alignment adjustment between the clutch drive coupler and meter shaft.

LF212299-4

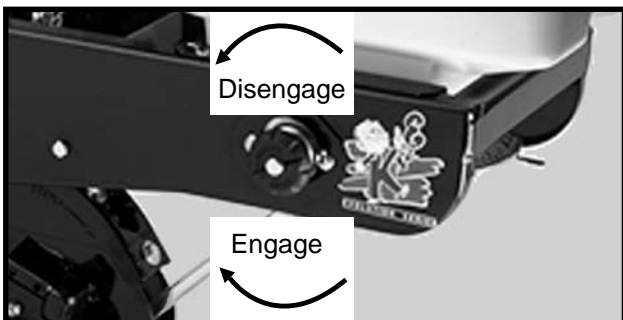

GRANULAR CHEMICAL BANDING OPTIONS

Granular chemical banding options allow 4 ½" slope-compensating banding or straight drop in-furrow placement.

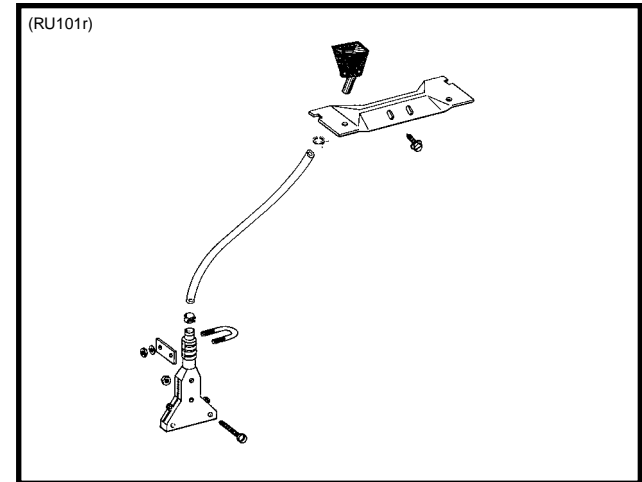

4 ¼" Slope-Compensating Bander

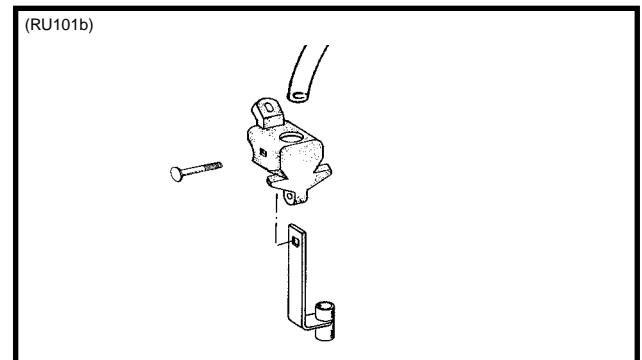

Straight Drop In-Furrow Placement

GRANULAR CHEMICAL BANDER SHIELD

The optional granular chemical bander shield is designed to be installed onto the underside of the wheel arm stop to shield crop residue from lodging in the granular chemical bander.

(RU83m)

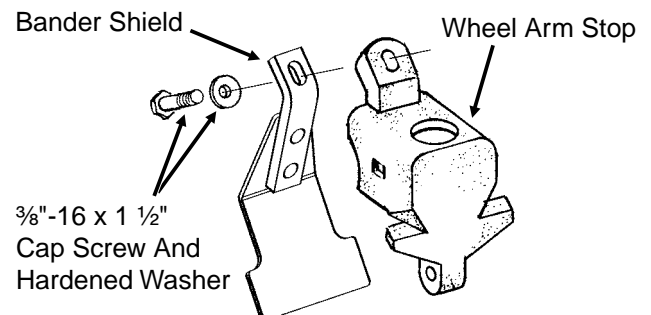

ROW UNIT OPERATION

INTERPLANT® PUSH ROW UNIT LOCKUPS

Push row unit lockups are designed to allow the push row units to be locked in the raised position.



WARNING: Always install all safety lockup devices or lower planter to the ground before working under or around the machine.

D062603106

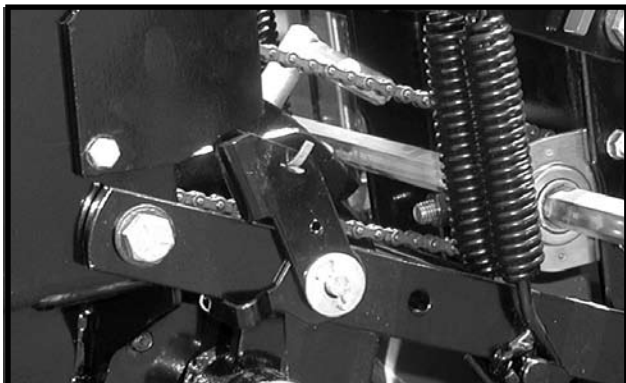

Push Row Unit Locked In Raised Position

D062603103

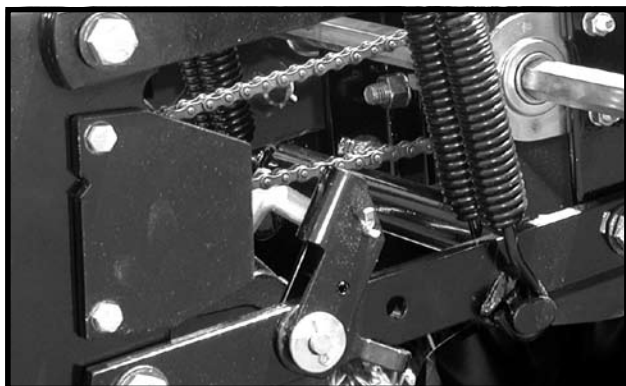

Lockup Released For Field Operation

D062603106a

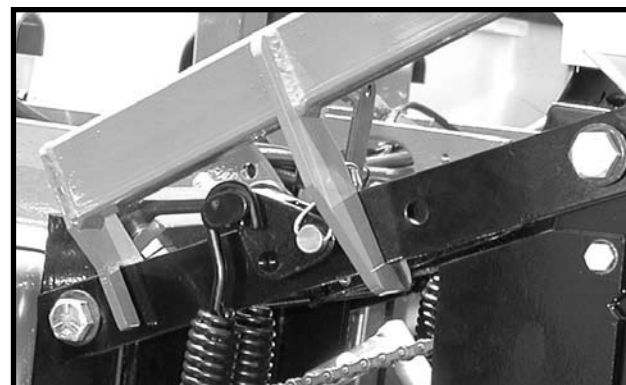

Lift Lever Positioned To Lift Push Row Unit

To lock in raised position:

1. Set row unit down pressure springs to minimum setting.
2. Lower the planter to the planting position.
3. Empty seed hoppers.
4. On each push row unit lockup, flip the spring tab forward.

D060499108



5. Using the lift lever, raise the push row unit to allow the spring loaded lockups to snap into locked position under the row unit stops.
6. Repeat Steps 4 and 5 on remaining push row units.

To release lockups:

1. Lower the planter to the planting position.
2. On each push row unit lockup, flip the spring tab rearward.

D060499107

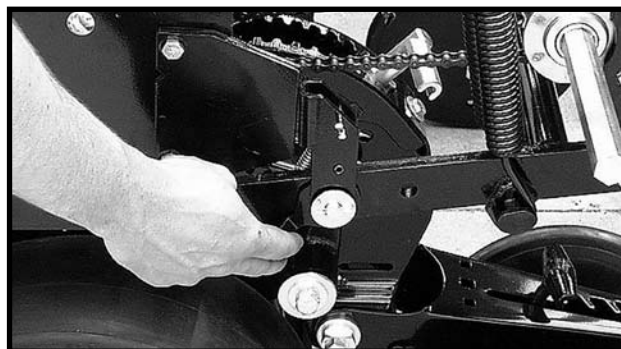

3. Using the lift lever, raise the push row unit to allow the spring loaded lockups to snap out of locked position. Lower row unit to the ground.
4. Repeat Step 3 on remaining push row units.

D070699109



Lift Lever In Storage Location

ROW UNIT OPERATION

INTERPLANT® PUSH ROW UNIT CLUTCH SPROCKETS

D032901171

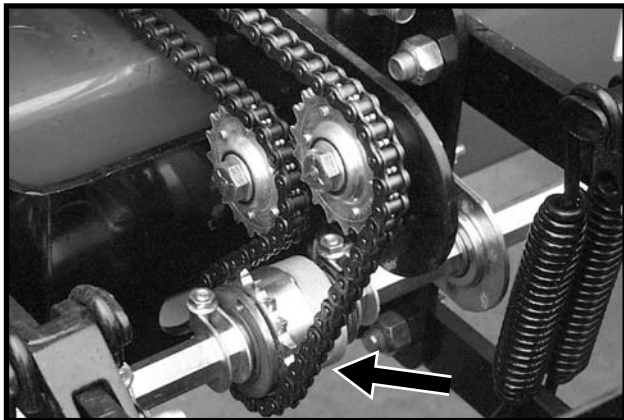

The push row unit clutch sprockets are designed to allow the push row unit drill shafts to be disengaged when only the pull row units are being used.

To disengage the push row unit drill shaft using the clutch sprocket, rotate the knurled collar on the clutch sprocket ¼ turn. Then using a 7/8" wrench on the drill shaft, rock the drill shaft slightly to take pressure off of the spring loaded pins in the clutch to allow the pins to "pop" out, disengaging the drive. To engage the drive, rotate the knurled collar ¼ turn and turn the drill shaft with a 7/8" wrench until the drive pins engage the drive sprocket.



WARNING: Always install all safety lockup devices or lower planter to the ground before working under or around the machine.

INTERPLANT® PUSH ROW UNIT VACUUM HOSE SHUTOFF

D12140617

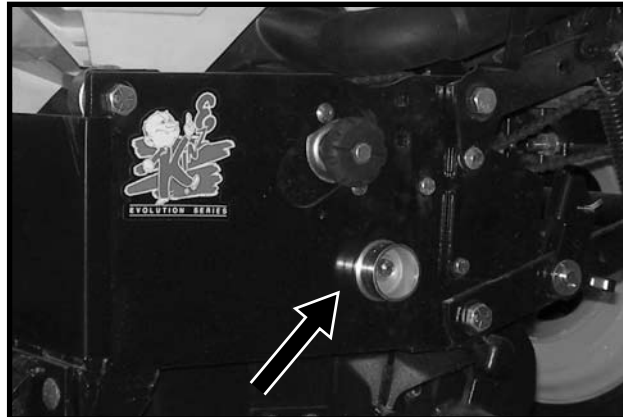

D10280511

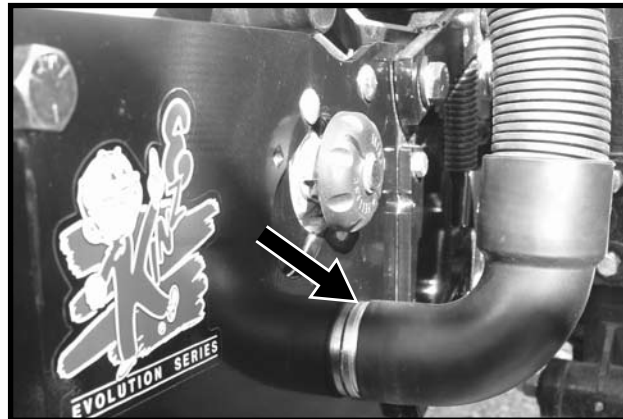

When the push row units are not being used, move the row unit end of the 2" vacuum hose on each push row unit from the seed meter vacuum cover to the storage mount located on the side of the shank as shown.



WARNING: Always install all safety lockup devices or lower machine to the ground before working under or around the machine.

LUBRICATION

The following pages show the locations of all lubrication points. Proper lubrication of all moving parts will help ensure efficient operation of your KINZE® planter and prolong the life of friction producing parts.

⚠ WARNING: Always install safety lockup devices or lower the machine to the ground before working under the machine.

LUBRICATION SYMBOLS

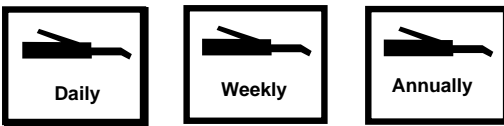

Lubricate at frequency indicated with an SAE multipurpose grease.



Lubricate at frequency indicated with a high quality SAE 10 weight oil or a quality spray lubricant.

SEALED BEARINGS

LF212199-3

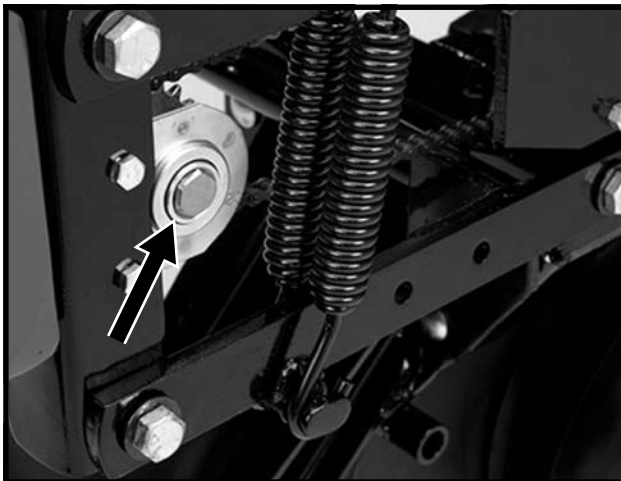

A number of sealed bearings are used on your KINZE® planter to provide trouble free operation. These are located in such areas as the drive shaft, row units and transmission bearings. Sealed bearings are lubricated for life. Due to the seals, relubrication is not practical.

DRIVE CHAINS

All transmission and drive chains should be lubricated daily with a high quality chain lubricant. Extreme operating conditions such as dirt, temperature or speed may require more frequent lubrication. If a chain becomes stiff, it should be removed, soaked and washed in solvent to loosen and remove dirt from the joints. Then soak the chain in oil so the lubricant can penetrate between the rollers and bushings.

D09280611a

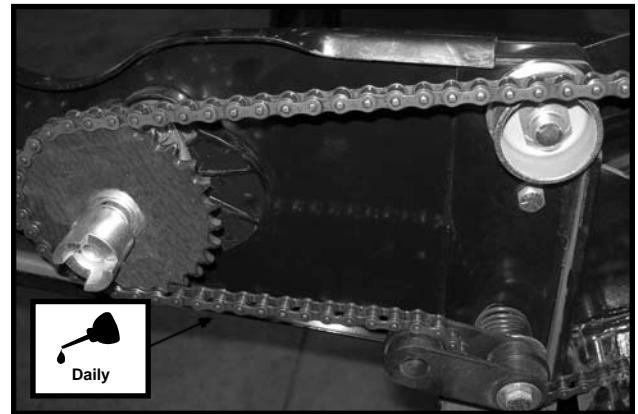

Pull Row Unit Drive Chains

D051705102

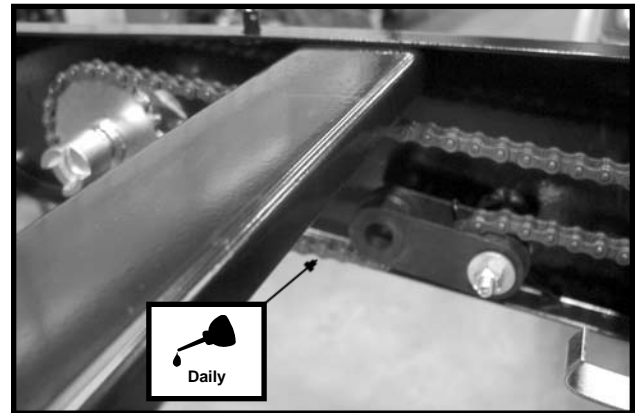

Row Unit Granular Chemical Drive Chains

D09280603a

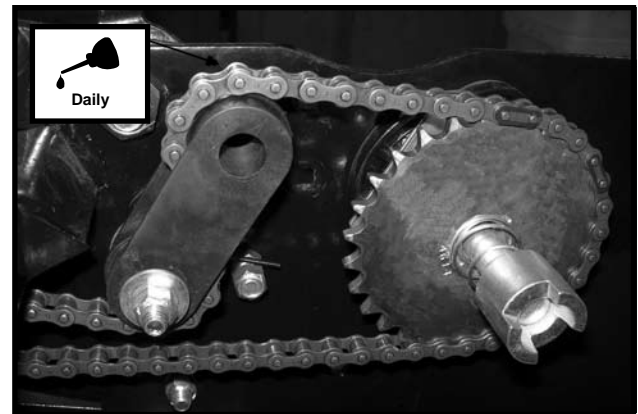

Push Row Unit Drive Chains

LUBRICATION

D032901153(PLTR52a)

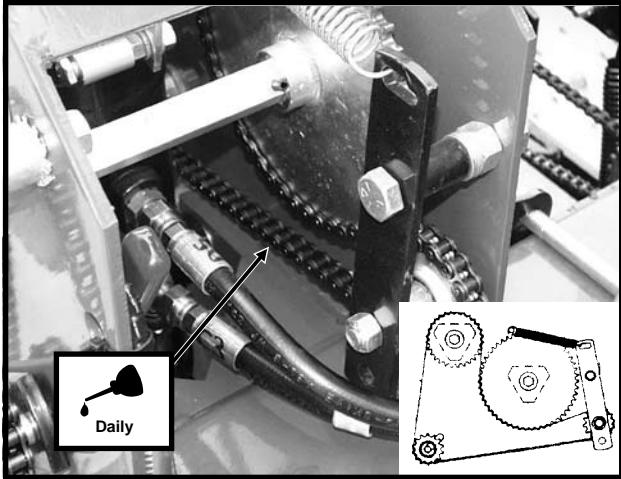

Inner Wheel Module Drive Chains

D032901150

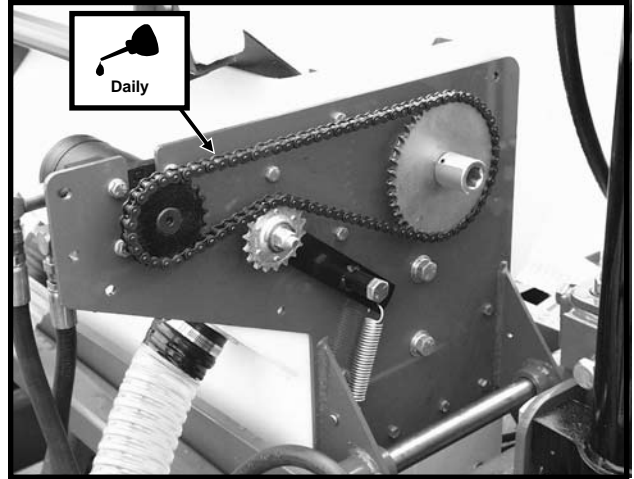

Seed Delivery System Hydraulic Motor Drive Chains

NOTE: Shown With Cover Removed - Slots in rear of covers allow chains to be oiled without removing covers.

D032901148

D021102206

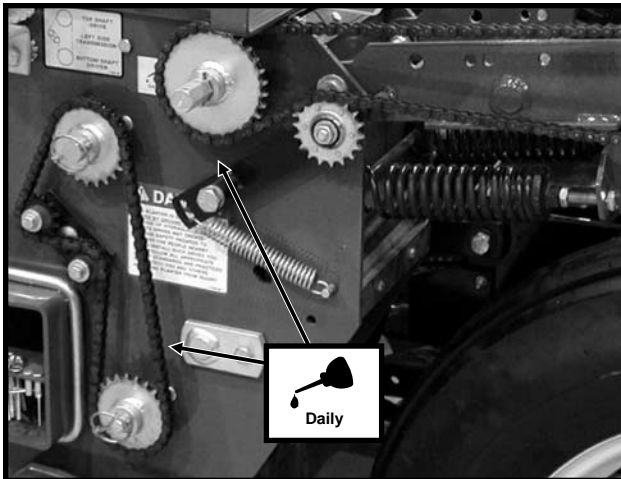

**Contact Wheel Drive Chains
Planter Seed Rate Transmission Drive Chains**

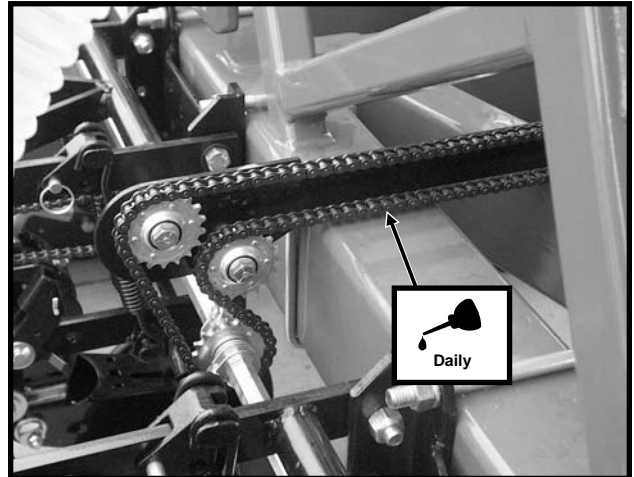

Interplant® System Drive Chains

D09070423

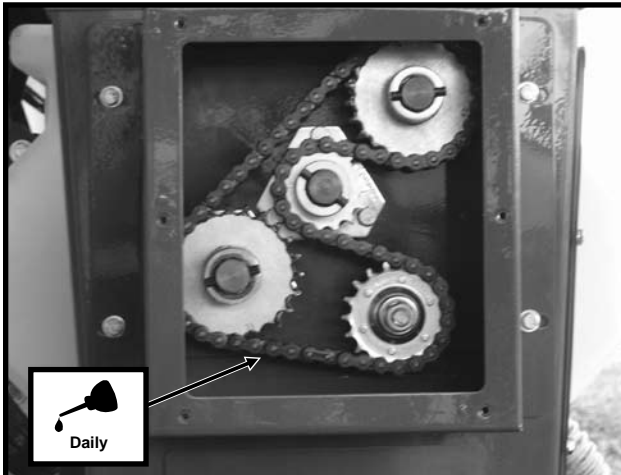

**Seed Delivery System Drive Chains
NOTE: Shown With Non-Production Cover For Visual Clarity**

D070204110

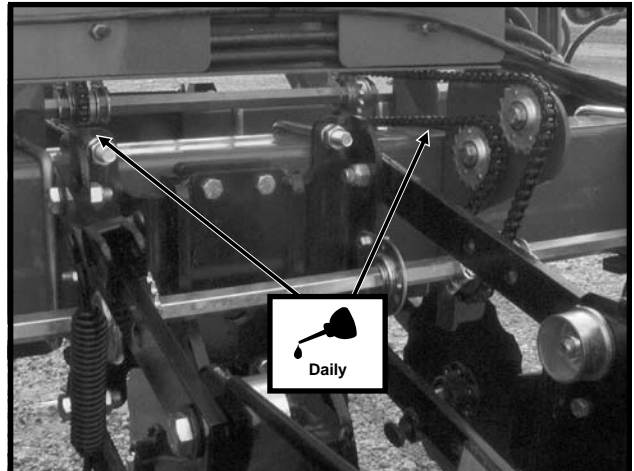

**Special Interplant® System Drive Chains
(Frame Mounted Coulters)**

LUBRICATION

LF092303103

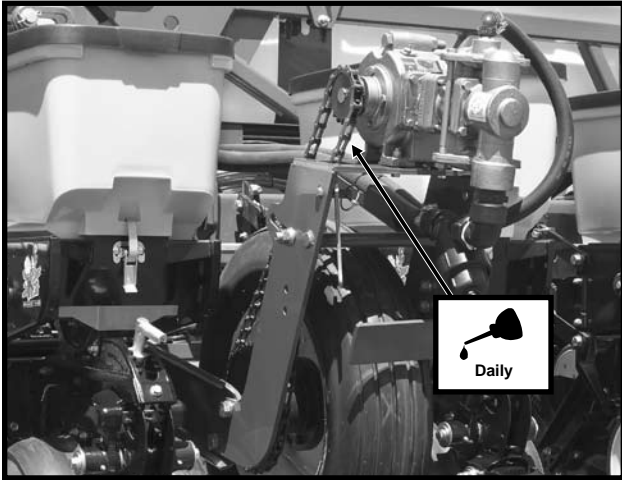

Liquid Fertilizer Piston Pump Ground Drive Wheel Chain

(TWL80b)

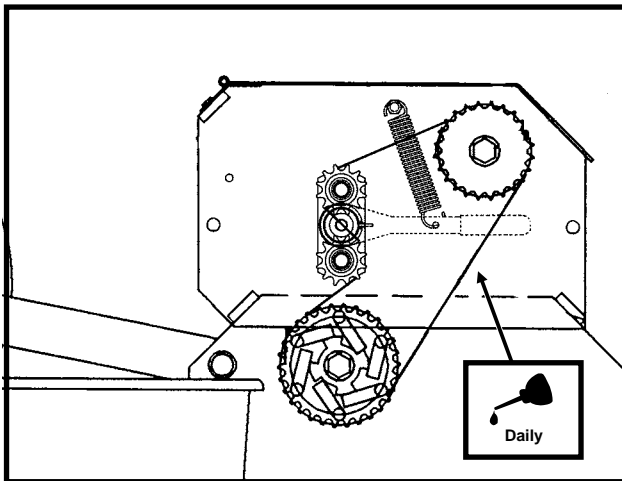

Two-Speed Point Row Clutch Module Drive Chain

(TWL84b)

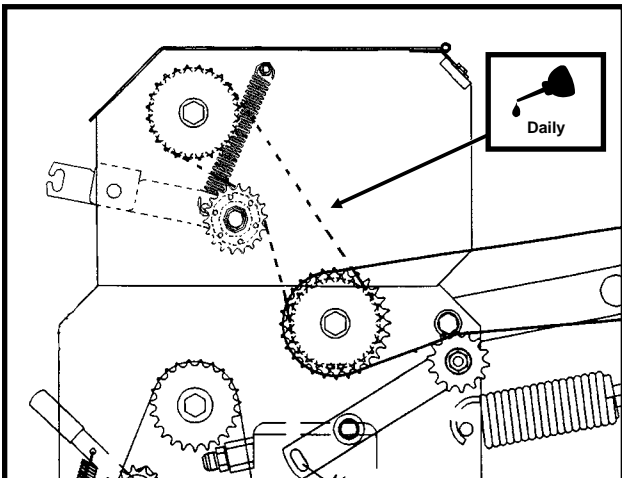

Two-Speed Point Row Clutch Inner Module Drive Chain

BUSHINGS

Lubricate bushings at the frequency indicated.

Using a torque wrench, check each bolt for proper torque. If bolt is loose, it should be removed and the bushing inspected for cracks and wear. Replace bushing if necessary **Only hardened flat washers should be used. Replace damaged flat washers with proper part. Torque hardware to 130 ft. lbs.**

D06300305

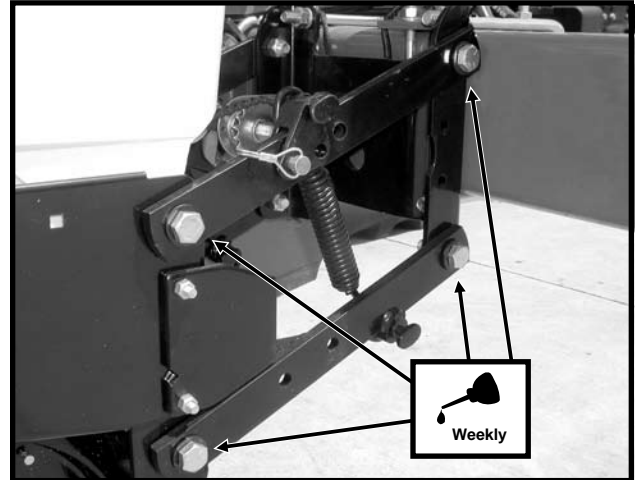

Pull Row Unit And/OR Push Row Unit Parallel Linkages (8 Per Row)

LF212299-22



Row Unit Mounted Disc Furrower Parallel Linkages (6 Per Row)

LUBRICATION

LF212199-2

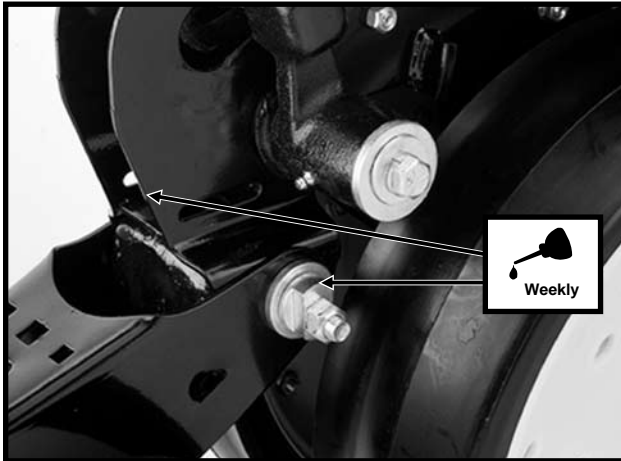

Row Unit "V" Closing Wheel Eccentric Bushings (2 Per Row)

D071603212

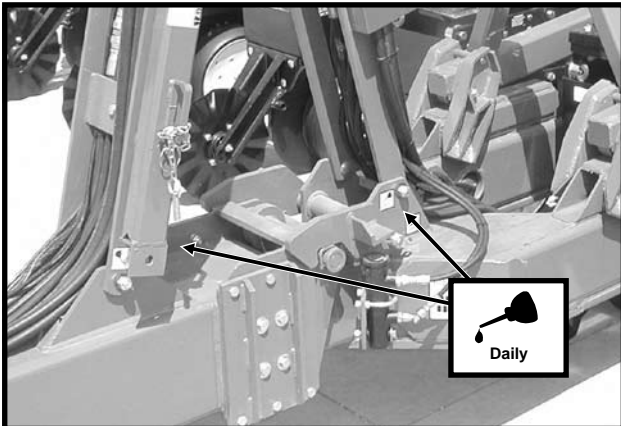

Hose Take-Up (6 Locations)

D032901120



Transport Latch (1 Location)

D021102206

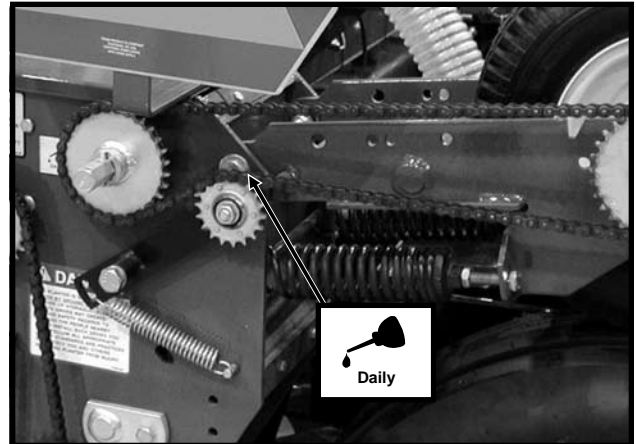

Contact Wheel Arm (2 Per Wheel Assembly)

IMPORTANT: CENTER POST AND POLY WEAR PADS REQUIRE NO LUBRICATION. ANY OIL OR GREASE WILL ATTRACT DIRT AND ACCELERATE WEAR ON THE CENTER POST AND ON THE POLY WEAR PADS.

BULK SEED HOPPER ELEVATOR CHAIN

Seed graphite used with each fill of seed will automatically lubricate the elevator chain. No additional lubrication is needed.

WRAP SPRING WRENCH ASSEMBLY

The chain idler is equipped with a wrap spring wrench. The wrench components may require occasional lubrication to operate correctly. Disassembly is required to lubricate. (a) Remove the 1/4"-20 x 1/2" cap screw that secures the idler with sprockets to the wrench tightener shaft. (b) Remove the wrap spring wrench from the planter. (c) Tip the wrap spring wrench on its side and lubricate using a high quality spray lubricant. Lubricant must be absorbed into the wrap spring area. (d) Reinstall wrench on planter.

D101303102



LUBRICATION

INTERPLANT® PUSH ROW UNIT LOCKUPS

D06099906

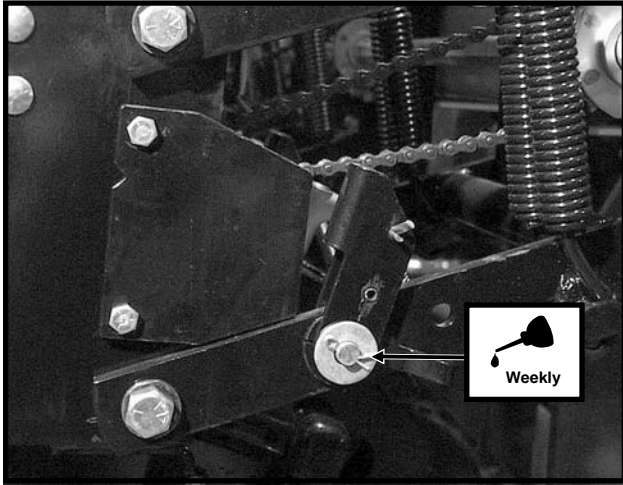

2 Per Row

CENTER POST

d071603307

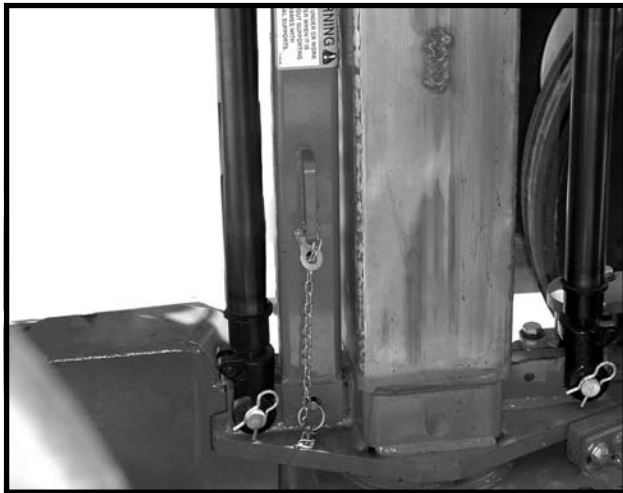

The center post is clad with stainless steel. To prolong service life keep stainless steel surface clean and free of any lubrication.

IMPORTANT: CENTER POST AND POLY WEAR PADS REQUIRE NO LUBRICATION. ANY OIL OR GREASE WILL ATTRACT DIRT AND ACCELERATE WEAR ON THE CENTER POST AND ON THE POLY WEAR PADS.

See "Wear Pad Replacement/Adjustment" for additional information.

U-JOINT SLIDES

Lubricate all U-joint slides daily with a high quality SAE 10 weight oil or a quality spray lubricant.

D040301107

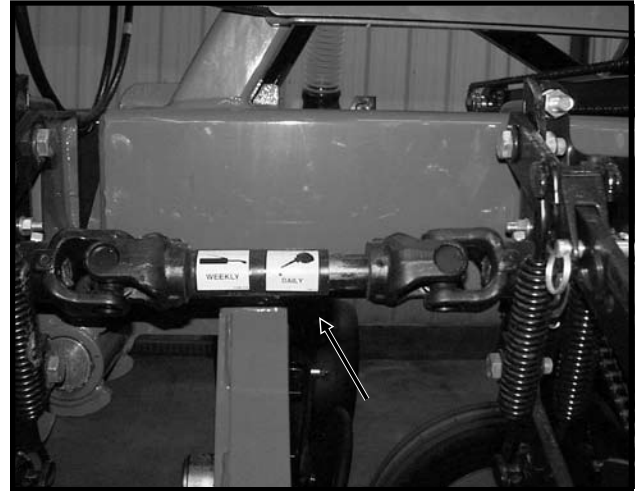

WHEEL BEARINGS

The transport wheel hubs are equipped with grease fittings. Pump grease into the hub until grease comes out around the seals. See "Grease Fittings" for lubrication frequency.

All wheel bearings should be repacked annually and checked for wear. This applies to all drive wheels, transport wheels and marker hubs.

To check for wear, lift the wheel off the ground. Check for endplay in the bearings by moving the tire side to side. Rotate the tire to check for roughness in the bearings. If bearings sound rough, the hub should be removed and the bearings inspected and replaced if necessary. See "Wheel Bearing Lubrication Or Replacement".

To repack wheel hubs, follow the procedure outlined for wheel bearing replacement with the exception that bearings and bearing cups are reused.

LUBRICATION

LIQUID FERTILIZER PISTON PUMP CRANKCASE OIL LEVEL

D071504102a/(A12330a)

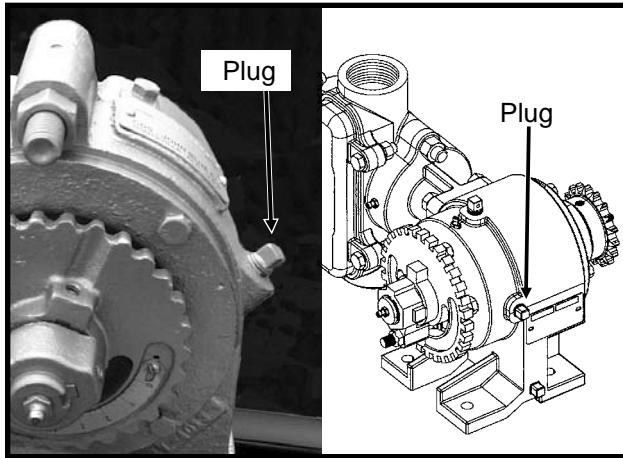

Check crankcase oil daily and maintain at plug level. Fill as needed with EP 90 weight gear oil. Total oil capacity is approximately $\frac{3}{4}$ pint.

Refer to operator and instruction manual supplied with the pump and flow divider for additional information.

GREASE FITTINGS

Those parts equipped with grease fittings should be lubricated at the frequency indicated with an SAE multipurpose grease. Be sure to clean the fitting thoroughly before using grease gun. The frequency of lubrication recommended is based on normal operating conditions. Severe or unusual conditions may require more frequent attention.



WARNING: Always install safety lockup devices or lower to the ground before working under or around the machine.

NOTE: Numbers on photo below correspond to photos on following pages showing lubrication frequencies.

D07160322

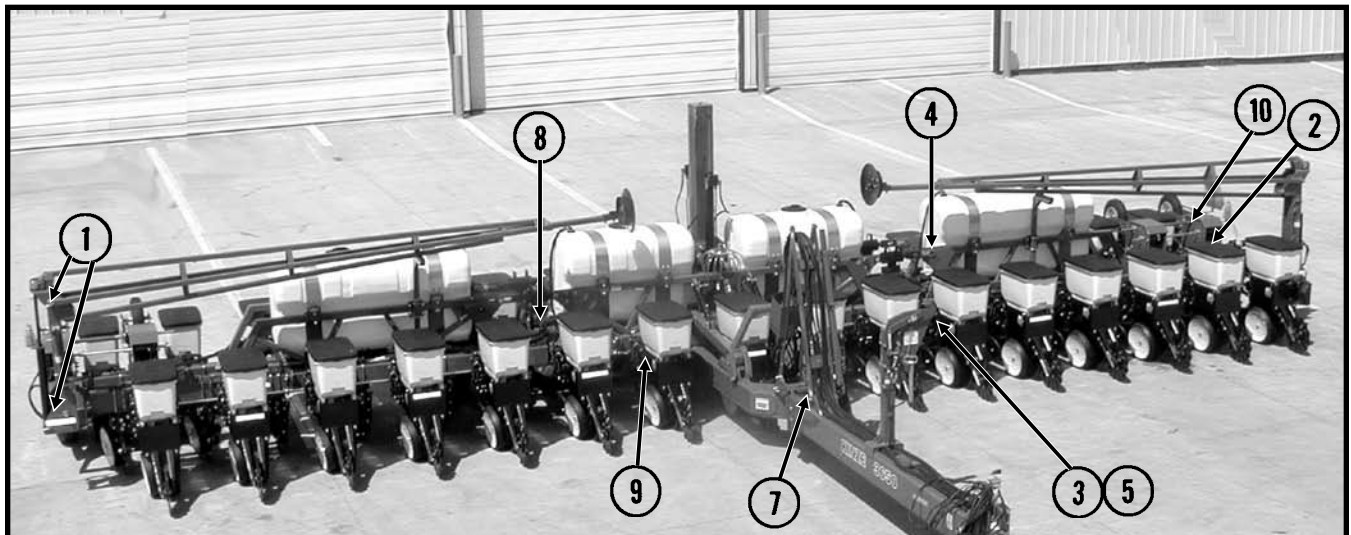

Model 3650 Conventional 16 Row 30" With Interplant® Package/Even-Row Push Row Unit And Liquid Fertilizer Package Shown

LUBRICATION

D071803218

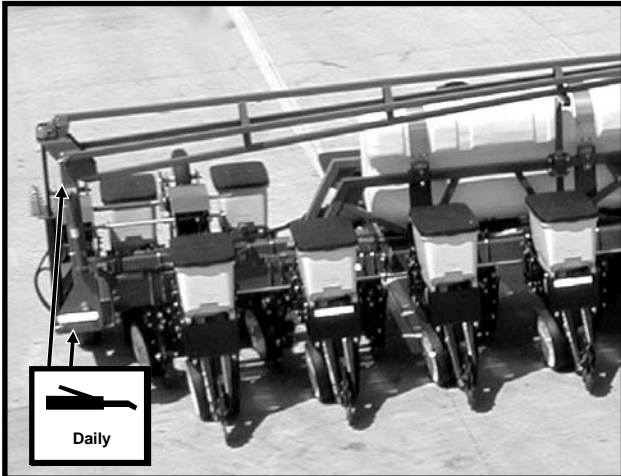

1. Row Marker Assemblies - 4 Zerks Per Assembly On 12 Row 30". 2 Zerks Per Assembly On 16 Row 30".

D032901181

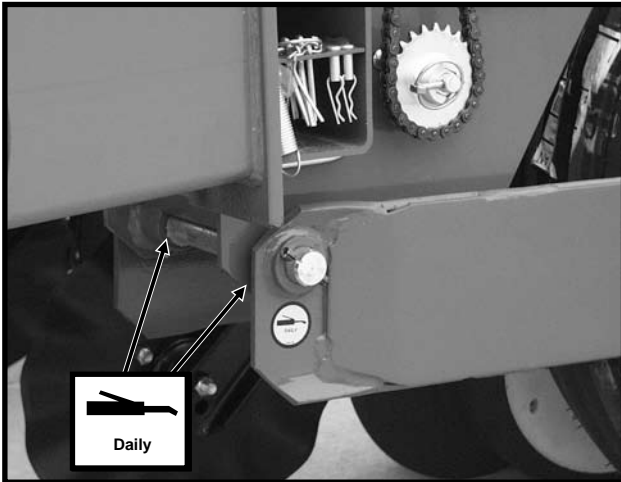

2. Wing Wheel Pivot - 2 Zerks Per Wheel Module

D030502105

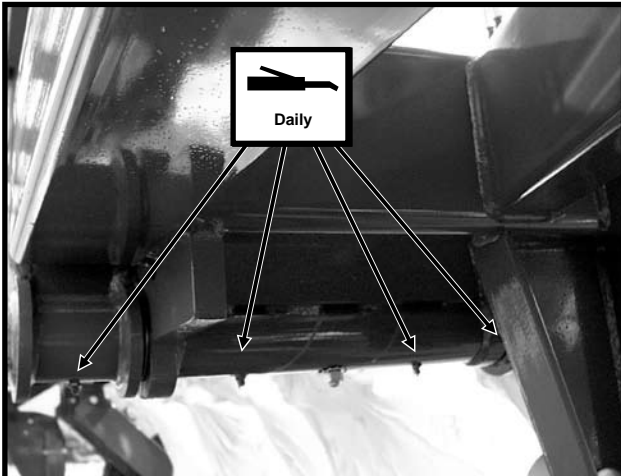

3. Wing Hinges - 4 Zerks Per Wing

D021102215

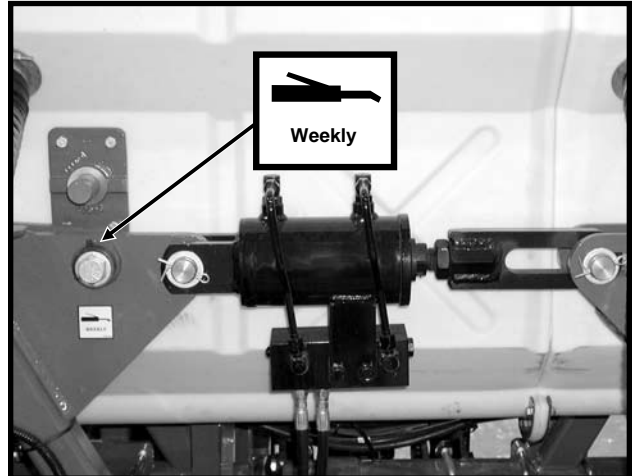

4. Link Pivot - 2 Zerks Per Wing

D071803307

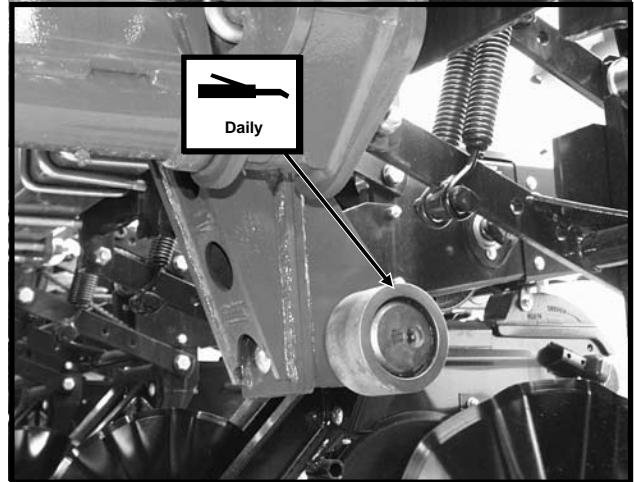

5. Cam Follower - 1 Zerk Per Follower

D121802120

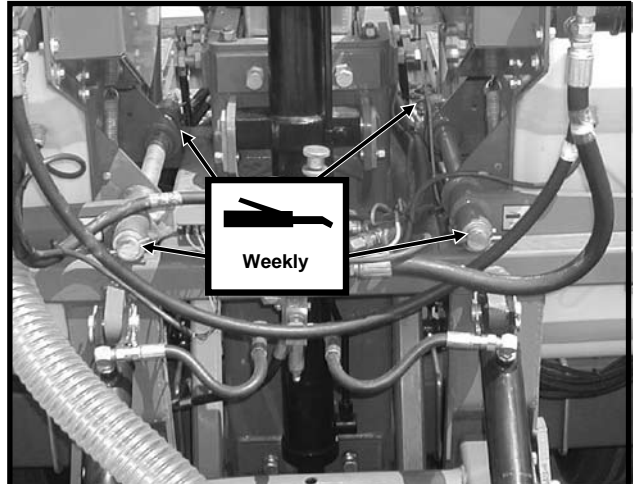

6. Inside Bulk Seed Hopper Pivot - 2 Zerks Per Pivot

LUBRICATION

D040301105

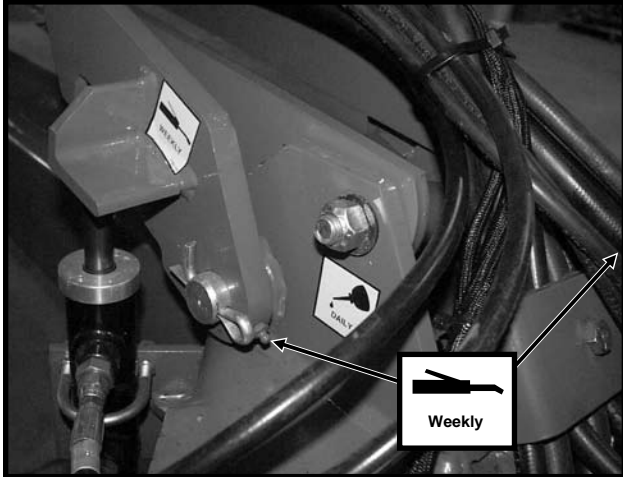

7. Tongue Hook - 2 Zerks

D040301107

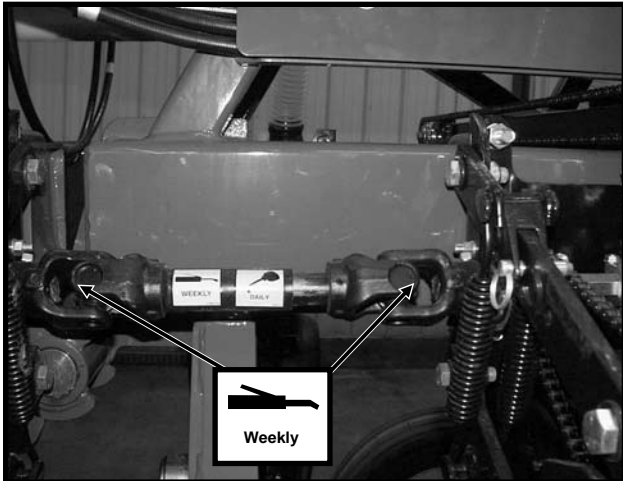

8. U-Joints - 2 Zerks Per Hinge Area

D071603344

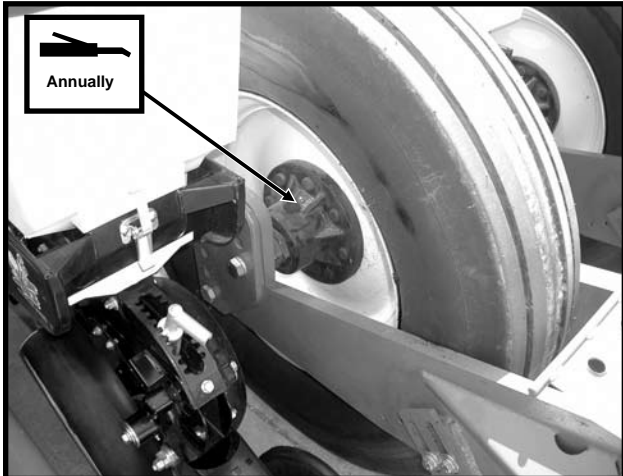

9. Transport Wheel Bearings - 1 Zerk Per Hub

05199819a

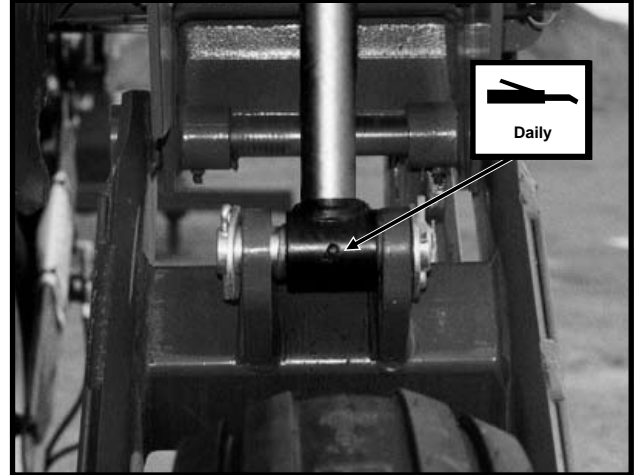

10. Wing Lift Cylinders - 1 Zerk Per Cylinder

D011006203

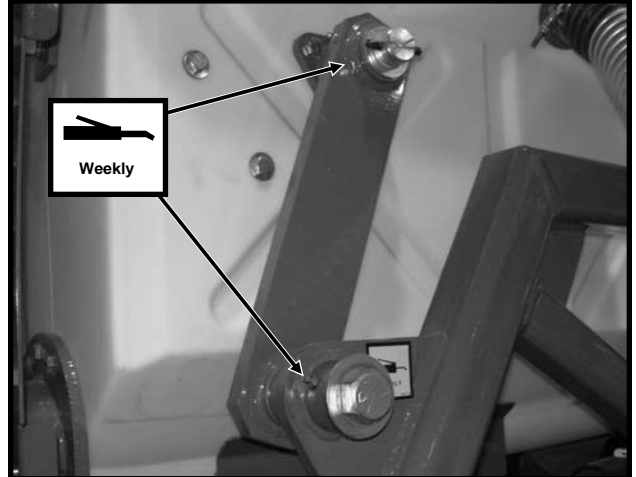

11. Outside Bulk Seed Hopper Link - 2 Zerks Per Link

LUBRICATION

Row Unit

LF212199-2

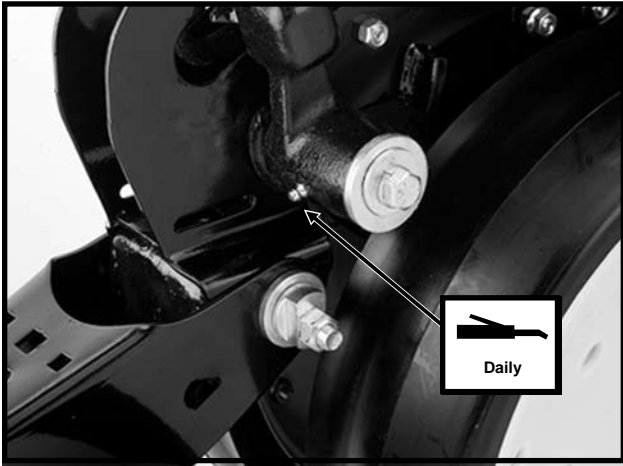

Gauge Wheel Arms - 1 Zerk Per Arm
(Seals in gauge wheel arm are installed with lip facing out to allow grease to purge dirt away from seal. Pump grease into arm until fresh grease appears between washers and arm.)

LF083002101

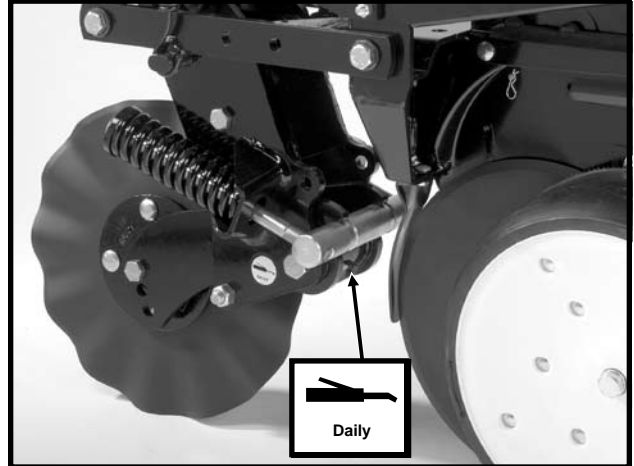

Frame Mounted Coulter - 1 Zerk Per Arm

LUBRICATION

Fertilizer Openers

D060801304

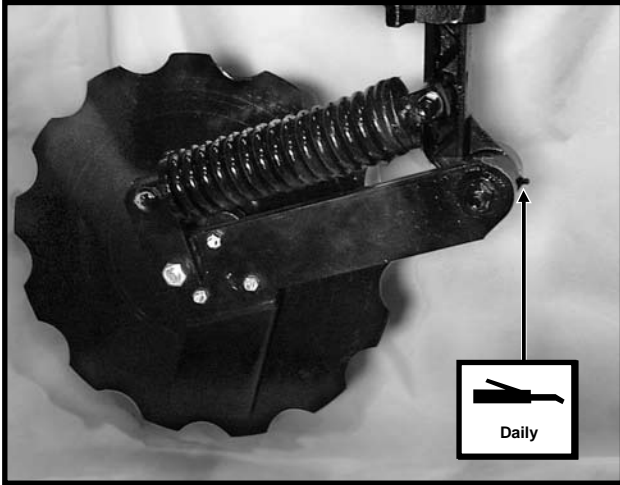

Notched Single Disc Fertilizer Opener - 1 Zerk

D06259919

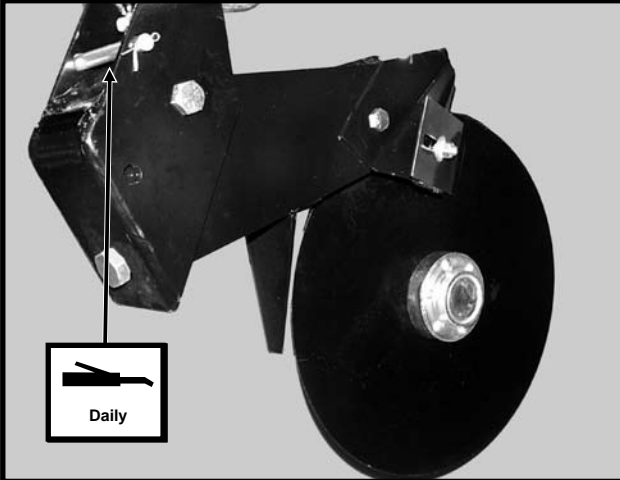

Double Disc Fertilizer Opener - 1 Zerk

D060801304

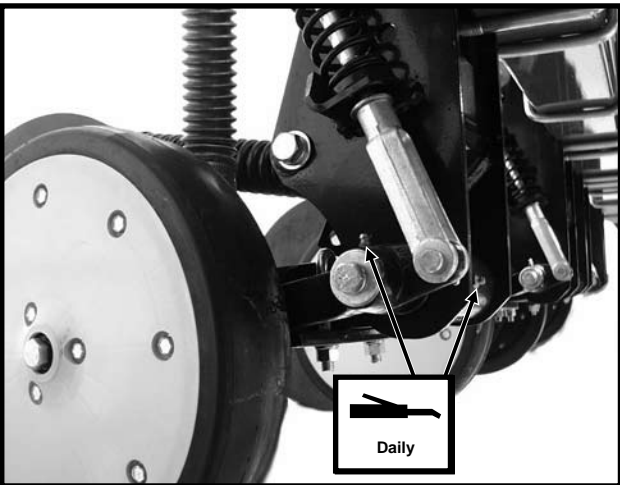

HD Single Disc Fertilizer Opener - 2 Zerks
(Located On Wheel Arm And Opener Mount)

D060801303

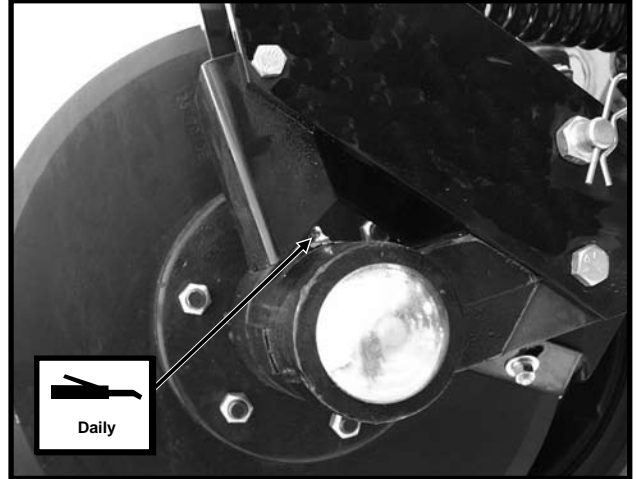

HD Single Disc Fertilizer Opener - 1 Zerk
(Located On Disc Opener Spindle Hub)

Liquid Fertilizer Attachment

D071504102a

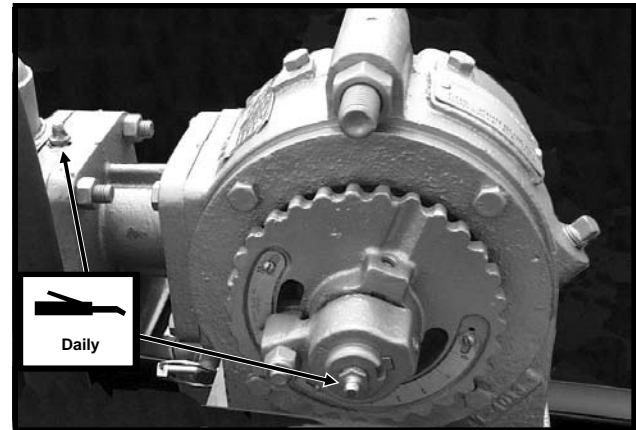

Piston Pump - 2 Zerks (Fill zerk on outboard stuffing box until lubricant seeps out of drain hole in bottom.)

(A12330a)

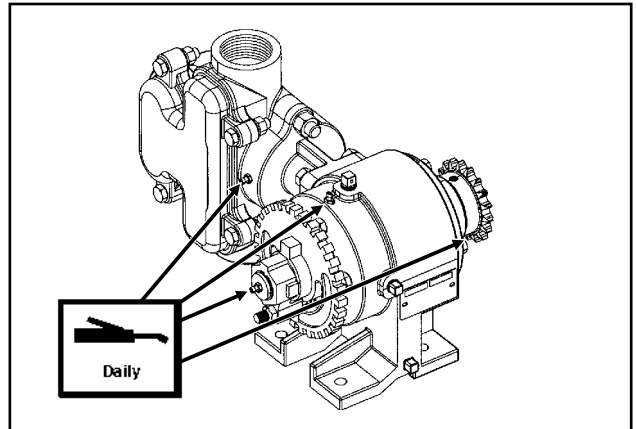

Liquid Fertilizer Piston Pump - 4 Zerks (Fill zerk on outboard stuffing box until lubricant seeps out of drain hole in bottom.)

MAINTENANCE

MOUNTING BOLTS AND HARDWARE

Before operating the planter for the first time, check to be sure all hardware is tight. Check all hardware again after approximately the first 50 hours of operation and at the beginning of each planting season thereafter.

All hardware used on the KINZE® planter is Grade 5 (high strength) unless otherwise noted. Grade 5 cap screws are marked with three radial lines on the head. If hardware must be replaced, be sure to replace it with hardware of equal size, strength and thread type. Refer to the torque values chart when tightening hardware.

Row Unit Parallel Linkage Bushing Hardware - 130 Ft. Lbs. (See “Bushings” in the Lubrication section of this manual.)

5/8" No Till Coulter Spindle Hardware - 120 Ft. Lbs.

Center Section Transport Tire Lug Nuts - 125 Ft. Lbs.

Wing Ground Drive Tire Lug Bolts - 90 Ft. Lbs.

IMPORTANT: Over tightening hardware can cause as much damage as under tightening. Tightening hardware beyond the recommended range can reduce its shock load capacity.

IMPORTANT: Torque setting for 5/8"-18 hex jam nut that secures fan impellor assembly to motor shaft is 50 ft. lbs.

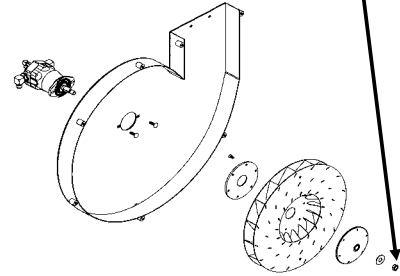

TORQUE VALUES CHART - PLATED HARDWARE

Bolt Diameter	Grade 2		Grade 5		Grade 8	
	Coarse	Fine	Coarse	Fine	Coarse	Fine
1/4"	50 In. Lbs.	56 In. Lbs.	76 In. Lbs.	87 In. Lbs.	9 Ft. Lbs.	10 Ft. Lbs.
5/16"	8 Ft. Lbs.	9 Ft. Lbs.	13 Ft. Lbs.	14 Ft. Lbs.	18 Ft. Lbs.	20 Ft. Lbs.
3/8"	15 Ft. Lbs.	17 Ft. Lbs.	23 Ft. Lbs.	26 Ft. Lbs.	33 Ft. Lbs.	37 Ft. Lbs.
7/16"	25 Ft. Lbs.	27 Ft. Lbs.	37 Ft. Lbs.	41 Ft. Lbs.	52 Ft. Lbs.	58 Ft. Lbs.
1/2"	35 Ft. Lbs.	40 Ft. Lbs.	57 Ft. Lbs.	64 Ft. Lbs.	80 Ft. Lbs.	90 Ft. Lbs.
9/16"	50 Ft. Lbs.	60 Ft. Lbs.	80 Ft. Lbs.	90 Ft. Lbs.	115 Ft. Lbs.	130 Ft. Lbs.
5/8"	70 Ft. Lbs.	80 Ft. Lbs.	110 Ft. Lbs.	125 Ft. Lbs.	160 Ft. Lbs.	180 Ft. Lbs.
3/4"	130 Ft. Lbs.	145 Ft. Lbs.	200 Ft. Lbs.	220 Ft. Lbs.	280 Ft. Lbs.	315 Ft. Lbs.
7/8"	125 Ft. Lbs.	140 Ft. Lbs.	320 Ft. Lbs.	350 Ft. Lbs.	450 Ft. Lbs.	500 Ft. Lbs.
1"	190 Ft. Lbs.	205 Ft. Lbs.	480 Ft. Lbs.	530 Ft. Lbs.	675 Ft. Lbs.	750 Ft. Lbs.
1 1/8"	265 Ft. Lbs.	300 Ft. Lbs.	600 Ft. Lbs.	670 Ft. Lbs.	960 Ft. Lbs.	1075 Ft. Lbs.
1 1/4"	375 Ft. Lbs.	415 Ft. Lbs.	840 Ft. Lbs.	930 Ft. Lbs.	1360 Ft. Lbs.	1500 Ft. Lbs.
1 3/8"	490 Ft. Lbs.	560 Ft. Lbs.	1100 Ft. Lbs.	1250 Ft. Lbs.	1780 Ft. Lbs.	2030 Ft. Lbs.
1 1/2"	650 Ft. Lbs.	730 Ft. Lbs.	1450 Ft. Lbs.	1650 Ft. Lbs.	2307 Ft. Lbs.	2670 Ft. Lbs.

NOTE: Unplated hardware and bolts with lock nuts should be torqued approximately 1/3 higher than the above values. Bolts lubricated prior to installation should be torqued to 70% of value shown in chart.



GRADE 2
No Marks



GRADE 5
3 Marks



GRADE 8
6 Marks

MAINTENANCE

CHAIN TENSION ADJUSTMENT

The drive chains have spring loaded idlers and therefore are self-adjusting. The only adjustment needed is to shorten the chain if wear stretches the chain and reduces spring tension. The pivot point of these idlers should be checked periodically to ensure they rotate freely.

Additional chain links can be found in the storage box located inside the planter frame.

D021102206

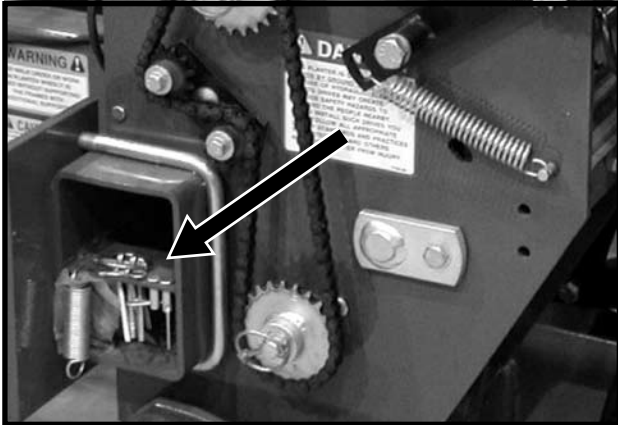

D020904101

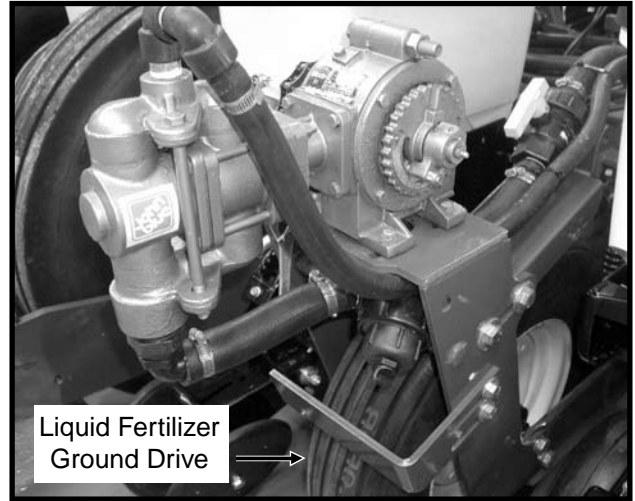

Tire pressure should be checked regularly and maintained as follows:

41 x 11R22.5" Transport (Center Section) . . .	75 PSI
7.50" x 20" Ground Drive (Wings)	40 PSI
4.80" x 8" Contact Drive	50 PSI
7.60" x 15" Ground Drive (Liquid Fertilizer Piston Pump)	40 PSI

TIRE PRESSURE

(TWL279)

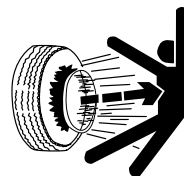
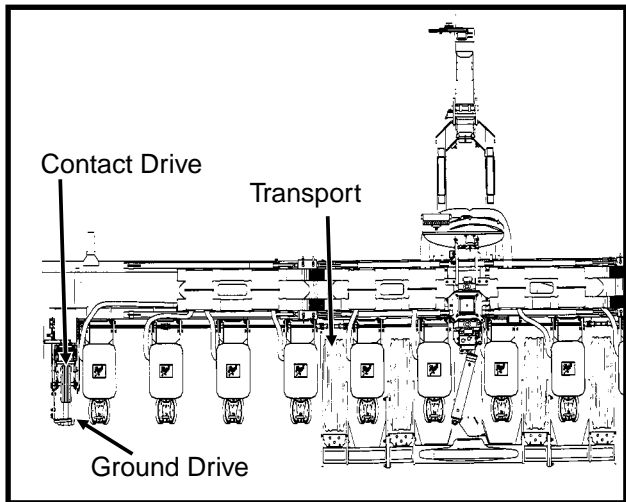

DANGER: Rim and tire servicing can be dangerous. Explosive separation of tire and rim parts can cause serious injury or death.

Do not attempt to mount a tire unless you have the proper equipment and experience to perform the job. This should only be done by persons properly trained and equipped to do the job.

Always maintain the correct tire pressures. Do not inflate the tires above the recommended pressures.

When inflating tires, use a clip-on air chuck and extension hose long enough to allow you to stand to one side and NOT in front of or over the tire assembly. Use a safety cage to enclose the tire and rim assembly when inflating.

Inspect tires and wheels daily. Do not operate with low pressure, cuts, bubbles, damaged rims or missing lug bolts and nuts.

MAINTENANCE

PTO PUMP DRIVE AND OIL COOLER OPTION

Drain the reservoir, clean strainer and change filter annually.

To drain the reservoir, disconnect the suction line (hose between reservoir and pump) from the reservoir and drain. To fully drain tank, raise the planter into field raised position. Refill system with SAE 10W-20 multigrade wide temperature range transmission hydraulic fluid. The reservoir capacity is approximately 10 gallons.

Replace filter with high quality 10 micron filter.

Start the system and allow to run with tractor at idle and the fan turned off for 1-2 minutes. Allow to run with tractor at idle and the fan at full speed for 1-2 minutes. Check reservoir fluid level and fill as required. To allow the fluid to expand when heated, the hydraulic fluid level should be within 1"-2" from the top of the reservoir after the pump has run and hydraulic hoses have been primed. Bring tractor to PTO speed and adjust flow control to the desired vacuum level using the flow control valve lever.

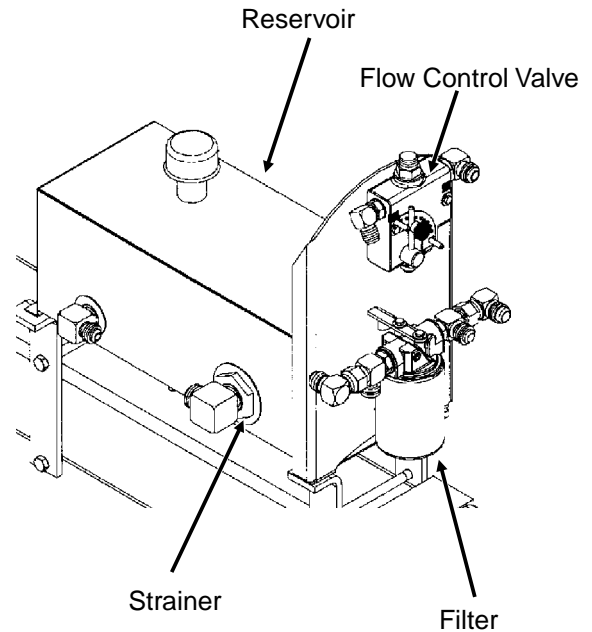

FRONT VIEW

PTO PUMP DRIVE AND OIL COOLER OPTION TROUBLESHOOTING

PROBLEM	POSSIBLE CAUSE	SOLUTION
Pump is squealing.	Lack of oil to pump.	Check for plugged suction strainer. Check oil level.
Oil temperature is high.	Low oil level.	Check oil level and add as required.
Desired fan speed cannot be achieved.	Low oil level.	Check oil level and add as required.
	Plugged filter.	Check and change as required.
Vacuum level is not displayed.	Digital vacuum gauge console power is OFF.	Turn ON.
	Cable not plugged in.	Check connection.
	Digital vacuum gauge console has no power.	Check fuse.

MAINTENANCE

CLOSING WHEEL TROUBLESHOOTING

PROBLEM	POSSIBLE CAUSE	SOLUTION
Closing wheel(s) leave severe imprint in soil.	Too much closing wheel down pressure.	Adjust closing wheel pressure.
Closing wheel(s) not firming soil around seed.	Insufficient closing wheel down pressure.	Adjust closing wheel pressure. Severe no till conditions may require use of cast iron closing wheels.
"V" closing wheel running on top of seed furrow.	Improper centering.	Align. See "V Closing Wheel Adjustment".

GAUGE WHEEL ADJUSTMENT

To prevent an accumulation of dirt or trash, gauge wheels should lightly contact the opener blades. Gauge wheels and opener blades should turn with only slight resistance.

To adjust clearance between gauge wheels and opener blades, add or remove machine bushings between the shank and gauge wheel arm. Store remaining machine bushings between gauge wheel arm and flat washer on outer side of gauge wheel arm.

NOTE: It may be desirable to space gauge wheel further from blade when operating in sticky soils.

(RU113g)

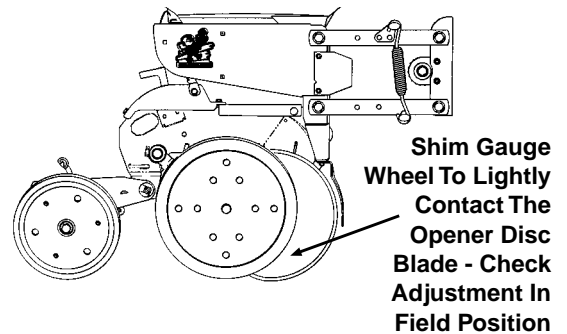

LF212199-2

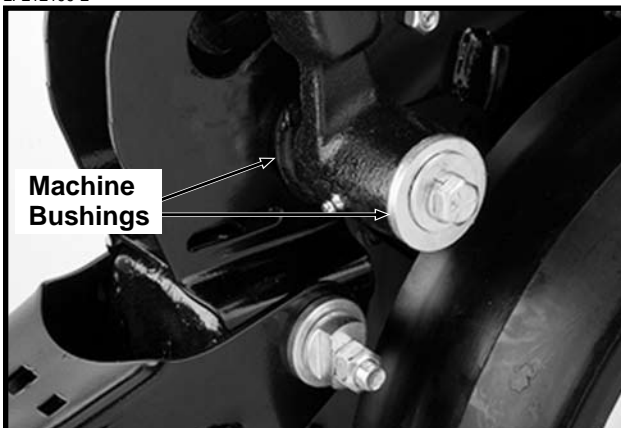

MAINTENANCE

GAUGE WHEEL ARM BUSHING AND/OR SEAL REPLACEMENT

(RU113g)

Gauge Wheel Arm Bushings/Seals

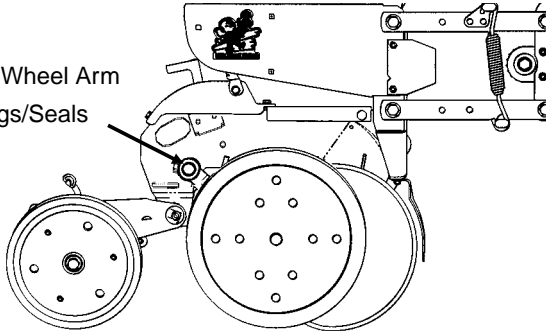

NOTE: A Gauge Wheel Arm Bushing And Seal Driver Kit (G1K296), for use in bushing and seal replacement, is available through your KINZE® Dealer.

To replace gauge wheel arm assembly bushing(s) and/or seal(s):

1. Remove gauge wheel from arm.
2. Remove the gauge wheel arm assembly from the shank assembly.
3. Remove seal and bushing and discard. Clean and dry inner bore.

(A7975/RU122)

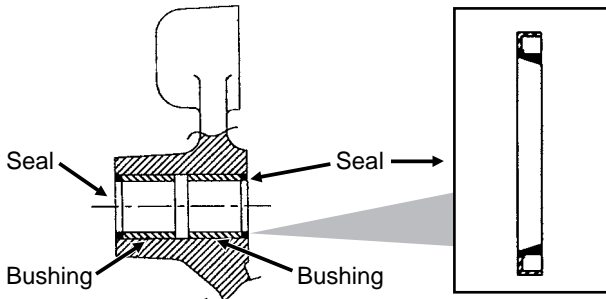

4. Drive/press replacement bushing inside bore of arm to a depth of .125" below flush.
5. Coat wiping edge of seal with grease.
6. Drive/press seal into place with lip to the outside as shown above.

NOTE: Use extra care to protect the sealing lip during installation. Apply uniform pressure to assemble the seal into the bore of the arm. Never apply a direct hammer blow to the seal surface.

7. Inspect gauge wheel pivot spindle.
8. Reinstall gauge wheel arm assembly and gauge wheel.

NOTE: Special machine bushing between gauge wheel arm and gauge wheel.

9. Shim for proper gauge wheel tire/disc blade clearance.
10. Lubricate with an SAE multipurpose grease.

GAUGE WHEEL ARM PIVOT SPINDLE REPLACEMENT

(RU113g)

Gauge Wheel Pivot Spindle

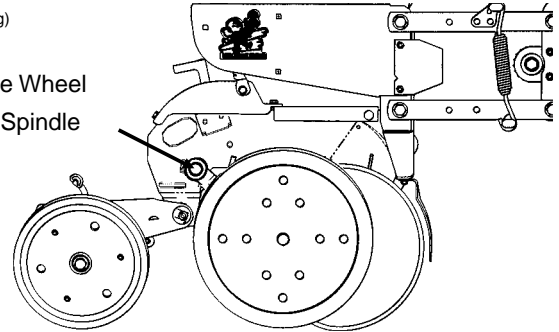

To replace gauge wheel pivot spindle:

1. Remove the gauge wheel and arm assemblies from the shank assembly.
2. Remove 1/2" x 3/4" cap screw that locks the pivot spindle in place and remove the spindle.

D06189902

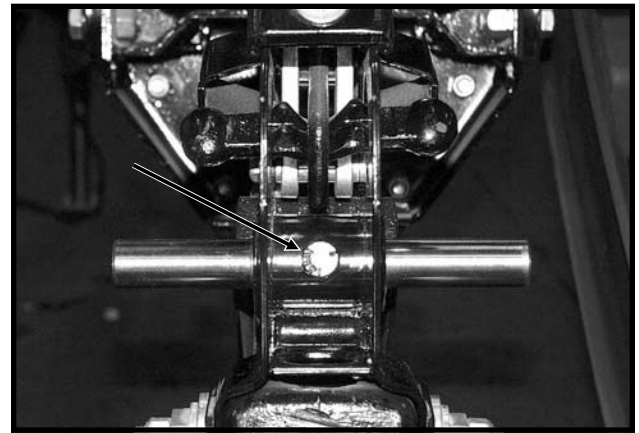

3. Install the replacement spindle and position as shown below. Exact centering is critical.

(A7966)

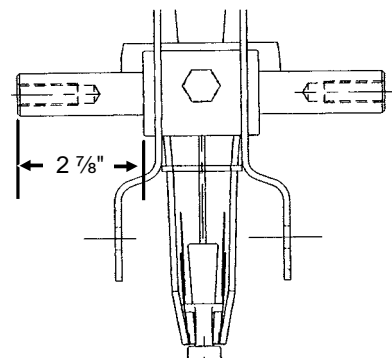

4. Install 1/2" x 3/4" cap screw and torque to lock pivot spindle in place.
5. Install gauge wheel and arm assemblies. Shim for proper gauge wheel tire/disc blade clearance.

MAINTENANCE

15" SEED OPENER DISC BLADE/ BEARING ASSEMBLY

Approximately 1" - 1 ½" of blade-to-blade contact should be maintained to properly open and form the seed trench. As the blade diameter decreases, due to wear, it will be necessary to relocate machine bushings from inside to outside to maintain approximately 1" - 1 ½" of contact.

NOTE: If proper blade-to-blade contact cannot be maintained after relocating machine bushings or if blade diameter wears below 14 ½", the blades should be replaced.

IMPORTANT: Excessive blade contact may result in premature disc opener bearing/hub failures and excessive wear on seed tube guard/inner scraper. When properly adjusted, if one blade is held in fixed position, the opposite blade should be able to be rotated with minimal force (Less than 5 pounds force at outer edge of blade).

(RU113g)

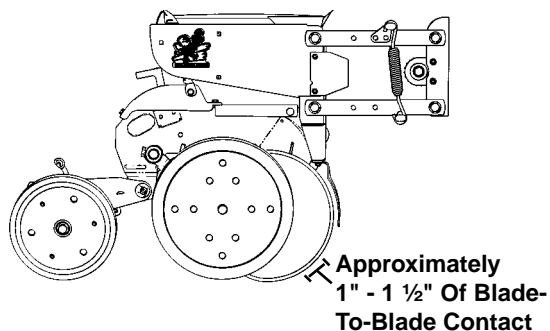

To replace disc blade/bearing assembly:

1. Remove gauge wheel.
2. Remove scraper.
3. Remove bearing dust cap.
4. Remove cap screw, washer and disc blade/bearing assembly. The machine bushings between the shank and disc blade are used to maintain the approximate 1" - 1 ½" of blade-to-blade contact.

IMPORTANT: Left hand side of opener uses a left hand threaded cap screw. DO NOT OVERTIGHTEN. Damage to shank threads will require replacement of row unit shank assembly.

5. Install machine bushing(s), new disc blade/bearing assembly, washer and cap screw. Torque ⅝"-11 Grade 5 cap screw to value shown in "Torque Values Chart".

NOTE: Replace disc blades only with disc blades of equal thickness.

6. Replace bearing dust cap.
7. Install scraper.
8. Install gauge wheel.

It may be necessary to replace only the bearing if there is excessive endplay or if the bearing sounds or feels rough when the disc blade is rotated.

To replace bearing:

1. Remove gauge wheel, scraper, bearing cap, cap screw, washer and disc blade/bearing assembly.
2. Remove ¼" rivets from bearing housing to expose bearing.
3. After installing new bearing, install three evenly spaced ¼" cap screws into three of the six holes in the bearing housing to hold the bearing and bearing housing in place. Install rivets in the other three holes. Remove ¼" cap screws and install rivets in those three holes.
4. Reinstall disc blade/bearing assembly, washer and cap screw. Torque ⅝"-11 cap screw to value shown in "Torque Values Chart" at the beginning of this section.
5. Replace bearing dust cap.
6. Install scraper and gauge wheel.

MAINTENANCE

SEED TUBE GUARD/INNER SCRAPER

The seed tube guard protects the seed tube and acts as the inner scraper for the seed opener disc blades.

Remove the seed tube and check for wear. Excessive wear on the seed tube indicates a worn seed tube guard. Replace the seed tube guard if it measures $\frac{5}{8}$ " or less at the lower end. A new seed tube guard measures approximately $\frac{7}{8}$ ".

LF212199-12



Shown With Gauge Wheel And Seed Opener Disc Blade Removed For Visual Clarity

IMPORTANT: No till planting or planting in hard ground conditions, especially when the planter is not equipped with no till coulters, and/or excessive blade-to-blade contact will increase seed tube guard wear and necessitate more frequent inspection and/or replacement.

To replace the seed tube guard, remove the seed tube and the two hex socket head cap screws which attach the seed tube guard. Hold the replacement seed tube guard centered between the seed opener disc blades. Install, but DO NOT tighten, the hex socket head cap screws. Using a clamp or vise-grip, squeeze the opener blades together in front of the seed tube guard. Tighten the seed tube guard retaining screws. Remove the clamps. The distance between the seed tube guard and opener blades should be equal on both sides. Reinstall seed tube.

IMPORTANT: Over tightening the hex socket head cap screws may damage the threads in the shank and require replacement of the shank. A seed tube guard that is worn excessively may allow the blades to wear into the row unit shank, also requiring replacement of the shank.

FRAME MOUNTED COULTER

LF083002101

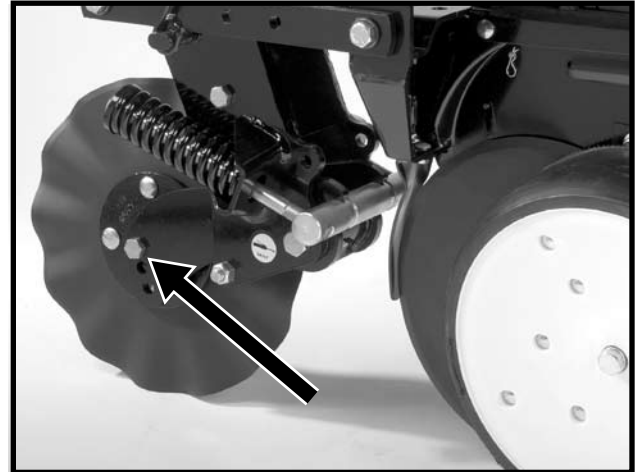

NOTE: Torque $\frac{5}{8}$ " spindle hardware to 120 ft. lbs.

See "Frame Mounted Coulters" in Row Unit Operation section of this manual for depth and spring adjustment.

When the 16" diameter coulters blade (1" fluted, 1" bubbled or $\frac{3}{4}$ " fluted) is worn to 14 $\frac{1}{2}$ " (maximum allowable wear), it should be replaced.

MAINTENANCE

RESIDUE WHEELS (For Use With Frame Mounted Coulter)

LF083002102

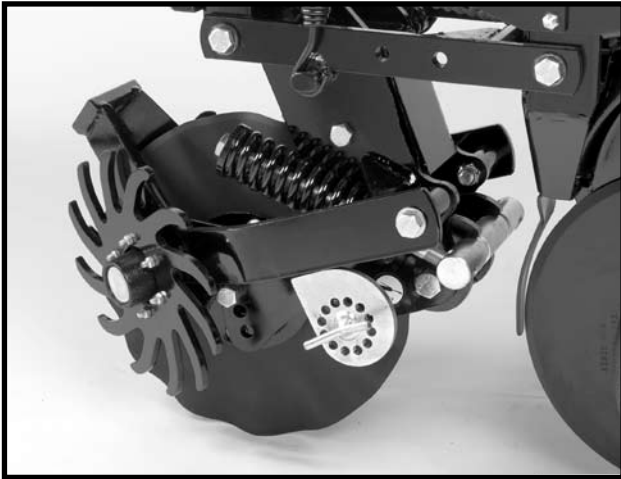

STYLE A

(RU154)

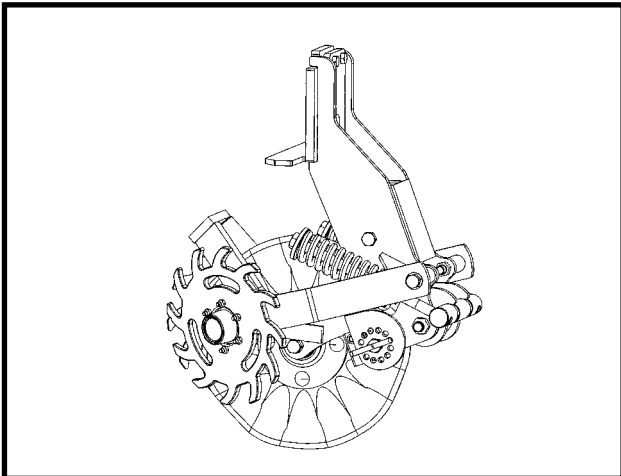

STYLE B

The wheel hub is equipped with sealed bearings. If a bearing sounds or feels rough when the wheel is rotated, replace the bearings.

ROW UNIT MOUNTED DISC FURROWER

LF212299-22

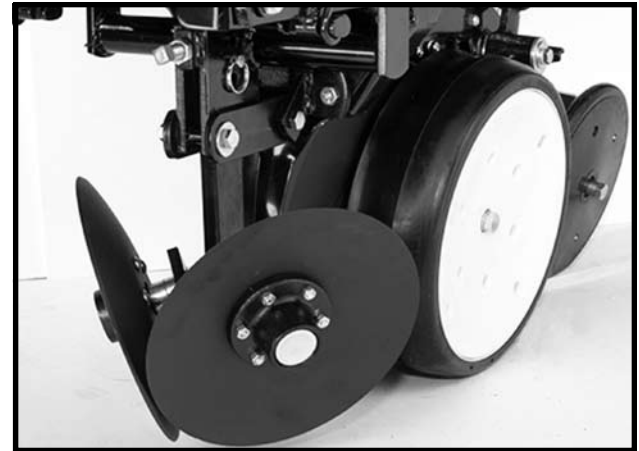

Lubricate the bushings in the support arm and mounting bracket at the frequency indicated in the Lubrication Section of this manual. Using a torque wrench, check each bolt for proper torque. If the bolt is loose, it should be removed and the bushing inspected for cracks and wear. Replace bushings as necessary. Only hardened flat washers should be used. **Replace damaged flat washers with proper part. Torque cap screws to 57 ft. lbs.**

The blade hubs are equipped with sealed bearings. If bearings sound or feel rough when the blade is rotated, replace the bearings.

When the 12" diameter blades (solid or notched) are worn to 11", they should be replaced.

MAINTENANCE

ROW UNIT MOUNTED NO TILL COULTER

LF212299-19a

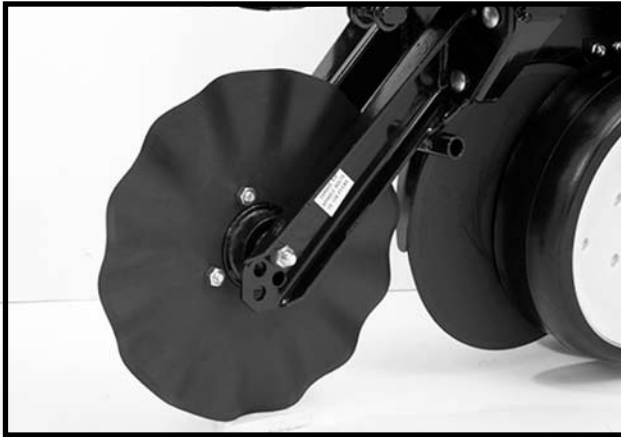

STYLE A (Two Sleeves For Installing Coulters Mounted Residue Wheels)

D05170706a



STYLE B (One Sleeve For Installing Coulters Mounted Residue Wheels)

Check periodically to be sure nuts and hardware are tightened to proper torque specification.

NOTE: Torque $\frac{5}{8}$ " spindle hardware to 120 ft. lbs.

Be sure the coulters are positioned square with the row unit and aligned in front of row unit disc opener.

The coulters blade can be adjusted to one of four settings. Initially the blade is set in the highest position. As the blade wears it can be adjusted to one of the three lower settings. See "Row Unit Mounted No Till Coulters" in Row Unit Operation section of this manual.

When the 16" diameter coulters blade is worn to 14½" (maximum allowable wear), it should be replaced.

COULTER MOUNTED RESIDUE WHEELS

LF212299-23



STYLE A - Used With Style A Row Unit Mounted No Till Coulters

D05170708a



STYLE B - Used With Style B Row Unit Mounted No Till Coulters

The wheel hubs are equipped with sealed bearings. If bearings sound or feel rough when the wheel is rotated, replace the bearings.

MAINTENANCE

ROW UNIT MOUNTED RESIDUE WHEEL

D101701113



STYLE A

(A12685)

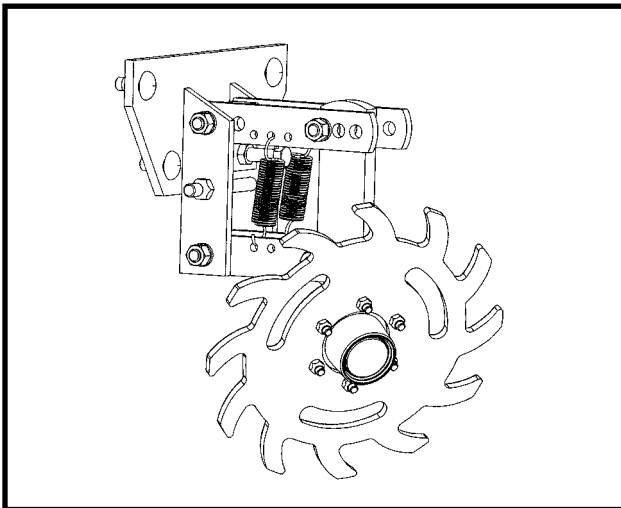

STYLE B

The wheel hub is equipped with sealed bearings. If a bearing sounds or feels rough when the wheel is rotated, replace the bearings.

GRANULAR CHEMICAL ATTACHMENT

Prior to storage of the planter, disengage the granular chemical drive by rotating the throwout knob $\frac{1}{4}$ turn counterclockwise. Remove the drive chain and empty and clean all granular chemical hoppers. Clean the drive chains and coat them with a rust preventive spray or submerge chains in oil. Inspect and replace any worn or broken parts.

Install hoppers and chains. Check chain alignment.

LF212299-4

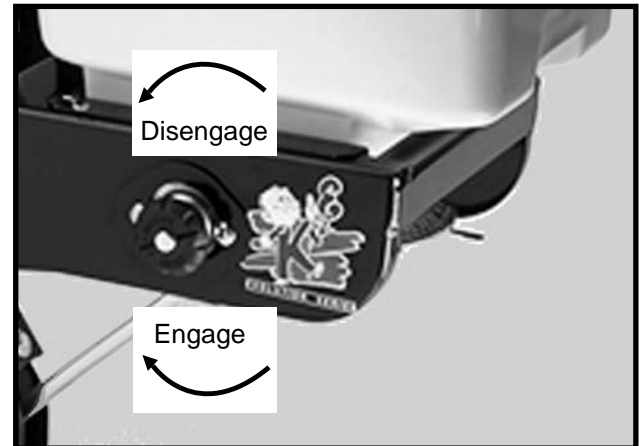

MAINTENANCE

SDS SEED DELIVERY SYSTEM AUGER REMOVAL

Augers are removed through the outer ends of the bulk seed hoppers.

To remove lower auger:

- STEP 1** Remove top, bottom and end covers.
- STEP 2** Loosen the six drive plate cap screws. Loosen jam nut and 1/2" x 4" adjustment bolt to remove all chain tension.
- STEP 3** Remove elevator chain connector link and remove chain.
- STEP 4** Cut 1/4" cotter pin from inner profile.
- STEP 5** Remove three screws from overlay. Remove overlay, bearing assembly and inner profile (shaft).
- STEP 6** Remove lower auger.
- STEP 7** Reassemble in reverse order.

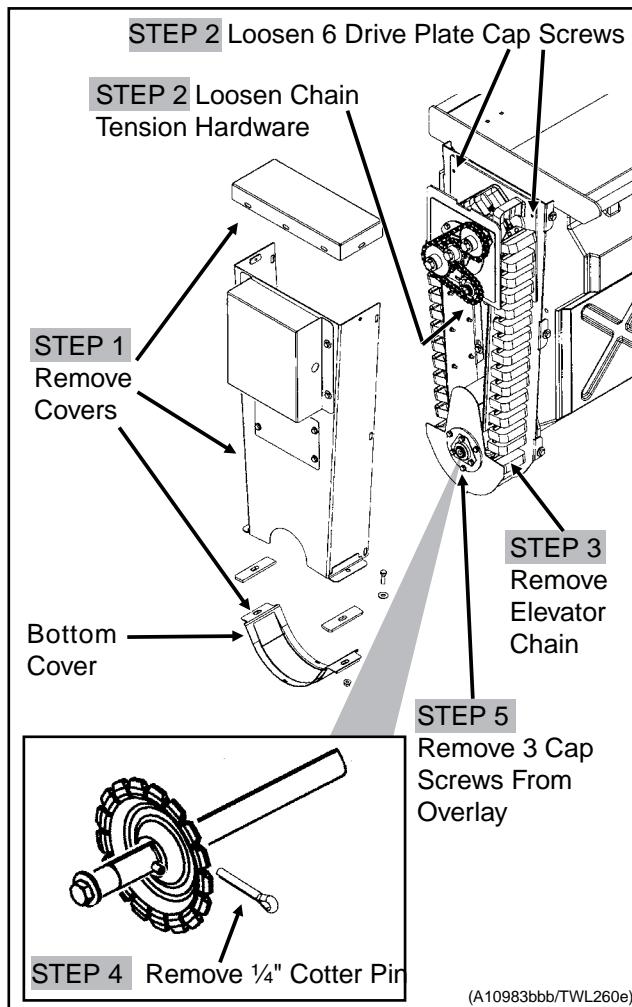

To remove upper auger:

- STEP 1** Remove upper cover.
- STEP 2** Remove chain idler, 72 pitch chain and both drive sprockets.
- STEP 3** Remove the three 5/16" cap screws at the drive plate assembly.
- STEP 4** Slide access overlay and auger assembly out of the hopper.
- STEP 5** Reassemble in reverse order.

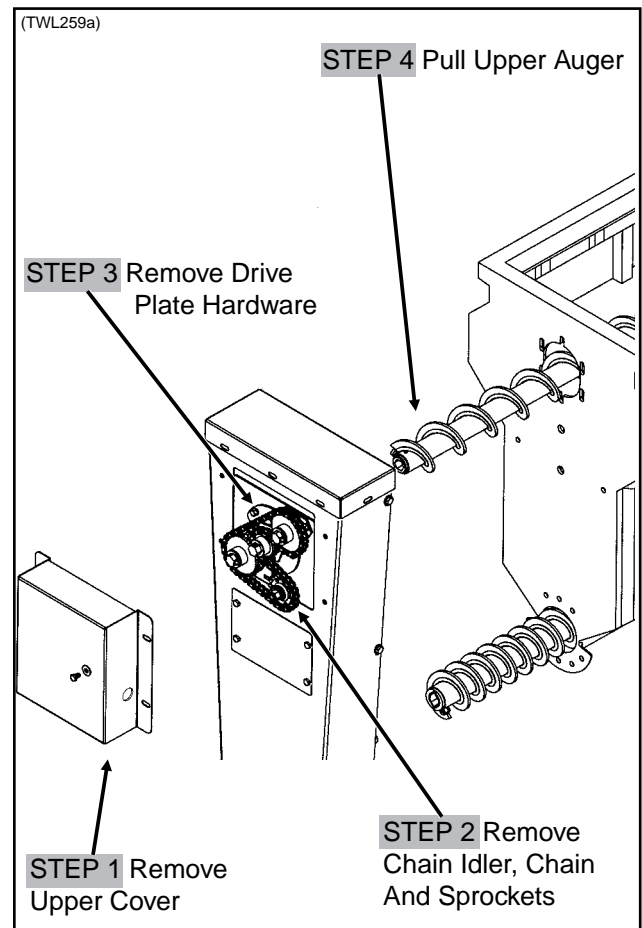

MAINTENANCE

BULK SEED HOPPER ELEVATOR CHAIN ADJUSTMENT

To adjust elevator chain tension:

STEP 1 Remove cover.

STEP 2 Loosen the six cap screws that attach the drive plate assembly.

STEP 3 Loosen jam nut and use the 1/2" x 4" hex head adjusting bolt to adjust elevator chain tension. Remove all slack from the chain.

NOTE: DO NOT OVER TIGHTEN THE CHAIN. There should be light to no contact between the chain and chain guides.

STEP 4 After adjustment is made, tighten six cap screws and replace cover.

NOTE: Adjust elevator chain after first 10 hours of operation.

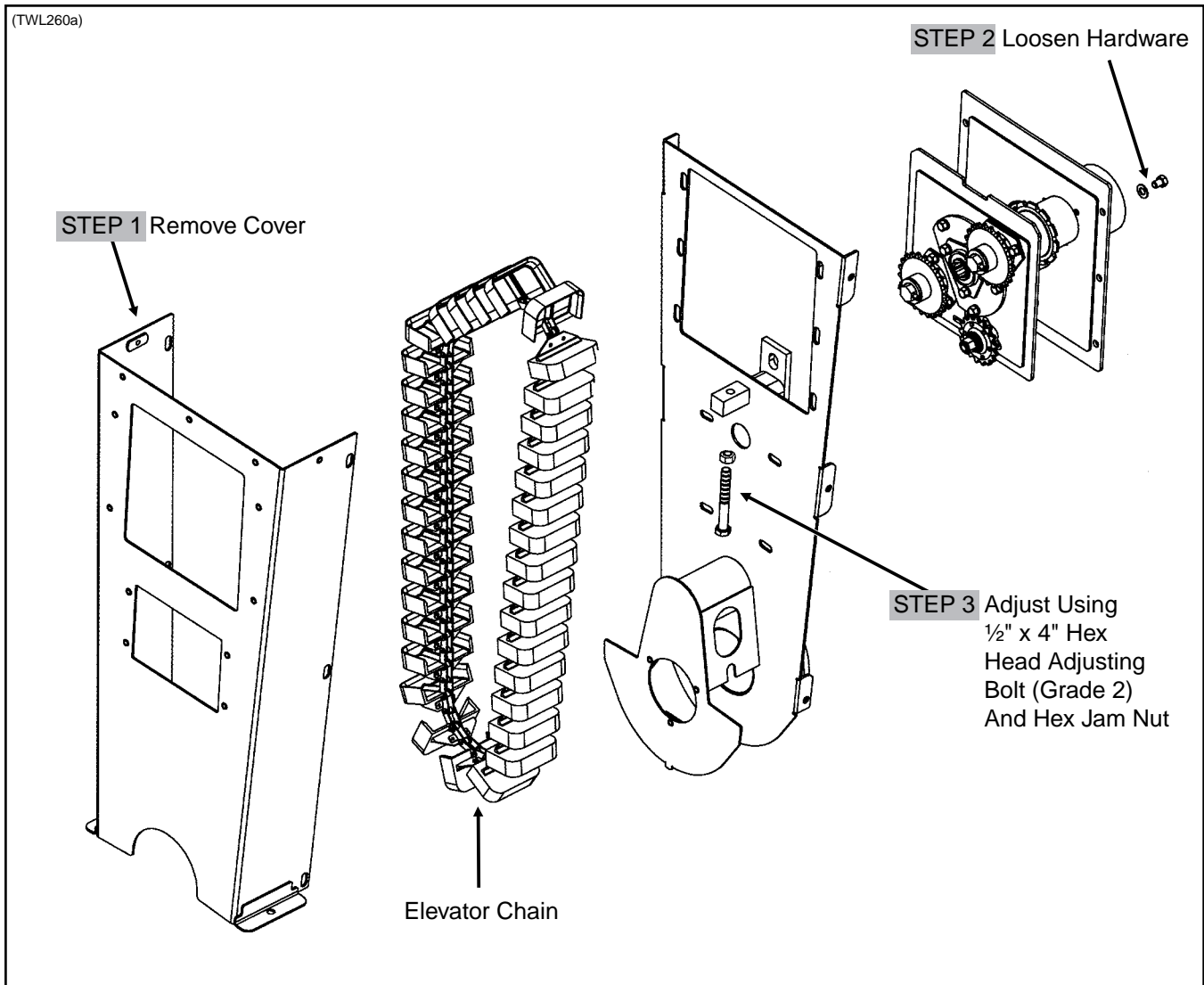

MAINTENANCE

KPM I/KPM II STACK-MODE ELECTRONIC SEED MONITORS TROUBLESHOOTING

PROBLEM	POSSIBLE CAUSE	SOLUTION
Single sensor communication alarm comes on (alarm on with no bargraph and a flashing row number on a single row).	Faulty seed tube sensor.	Replace sensor.
	Break in the harness just before the seed tube sensor.	Inspect for break in harness and repair. If break can't be found, replace harness section.
	Dirty or corroded connector.	Clean connector.
Sensor communication alarms come on for all sensors (alarm on with no bargraphs and flashing row numbers on all rows).	Faulty monitor.	Repair/Replace monitor.
	Break in the harness just after the monitor.	Inspect for break in harness and repair. If break can't be found, replace harness section.
	Dirty or corroded connector.	Clean connector.
Sensor communication alarms come on for some sensors (alarm on with no bargraphs and flashing row numbers on all rows).	Break in the harness.	Inspect for break in harness and repair. If break can't be found, replace harness section corresponding with the alarming sensors.
	Dirty or corroded connector.	Clean connector.
Faulty monitor values (such as speed, area, etc.) being displayed. (KPM II Stack-Mode Only)	Incorrect monitor settings.	Change settings to properly correspond to the system.
	Faulty radar/magnetic distance sensor.	Replace sensor.
	Improperly mounted radar sensor.	Properly mount sensor.
Underplanting or no planting alarm on a single sensor when planting (alarm on with a single bargraph segment on and a flashing row number on a single row).	Seed tube sensor is blocked.	Clean sensor.
	Faulty seed tube sensor.	Replace sensor.
	Meter not planting or underplanting.	Repair/replace meter.
	Chain broken or off sprocket.	Repair as necessary.
Seed tube sensor dirty or blocked warning comes on (after calibration, bargraph keeps flashing for a single row).	Seed tube sensor is dirty.	Clean sensor.
	Faulty seed tube sensor.	Replace sensor.
LED on the seed tube sensor will not come on.	Faulty seed tube sensor.	Replace sensor.
	Dirty or corroded connector.	Clean connector.
	Break in the harness just before the sensor.	Repair harness.
Erroneous MPH readings at idle. (Radar Distance Sensor Only)	Radar sensor not located in a stable location.	Relocate to a more stable location.

MAINTENANCE

KPM III ELECTRONIC SEED MONITOR TROUBLESHOOTING

PROBLEM	POSSIBLE CAUSE	SOLUTION
Single sensor communication alarm comes on.	Faulty seed tube sensor.	Replace sensor.
	Break in the harness just before the seed tube sensor.	Inspect for break in harness and repair. If break can't be found, replace harness section.
	Dirty or corroded connector.	Clean connector.
Sensor communication alarms come on for all sensors.	Faulty monitor.	Repair/Replace monitor.
	Break in the harness just after the monitor.	Inspect for break in harness and repair. If break can't be found, replace harness section.
	Dirty or corroded connector.	Clean connector.
Sensor communication alarms come on for some sensors.	Break in the harness.	Inspect for break in harness and repair. If break can't be found, replace harness section corresponding with the alarming sensors.
	Dirty or corroded connector.	Clean connector.
Faulty monitor values (such as speed, area, etc.) being displayed.	Incorrect monitor settings.	Change settings to properly correspond to the system.
	Faulty radar/magnetic distance sensor.	Replace sensor.
	Improperly mounted radar sensor.	Properly mount sensor.
Underplanting or no planting alarm on a single sensor when planting (alarm on with a single bargraph segment on and a flashing row number on a single row).	Seed tube sensor is blocked.	Clean sensor.
	Faulty seed tube sensor.	Replace sensor.
	Meter not planting or underplanting.	Repair/replace meter.
	Chain broken or off sprocket.	Repair as necessary.
Seed tube sensor dirty or blocked warning comes on.	Seed tube sensor is dirty.	Clean sensor.
	Faulty seed tube sensor.	Replace sensor.
LED on the seed tube sensor will not come on.	Faulty seed tube sensor.	Replace sensor.
	Dirty or corroded connector.	Clean connector.
	Break in the harness just before the sensor.	Repair harness.
Erroneous MPH readings at idle. (Radar Distance Sensor Only)	Radar sensor not located in a stable location.	Relocate to a more stable location.

MAINTENANCE

POINT ROW CLUTCH INSPECTION

The point row clutch is permanently lubricated and sealed and requires no periodic maintenance.

D032901166

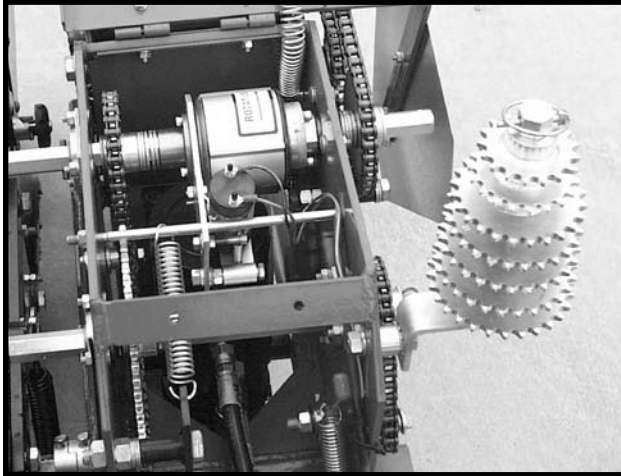

The right hand clutch operates clockwise and the left hand clutch operates counterclockwise. Therefore, some of the parts of the clutch such as the wrap spring differ from one side of the planter to the other. Be sure to use the correct repair part if a clutch must be repaired.

NOTE: The point row clutch input shaft on the R.H. side of the machine will have an "L" stamped on it and the shaft on the L.H. side of the machine will have an "R" stamped on it.

If the clutch or clutches fail to operate, first determine if the problem is electrical or mechanical. Place the operational switch in the RIGHT or LEFT position. When the switch is in the RIGHT or LEFT position and the fuse on the rear of the control console is in working condition, the red indicator light on the control console should be lighted. If light does not come on, check the fuses on the front of the control console. See "Point Row Clutch Troubleshooting" chart. If fuses are not blown, check the clutch and wiring harness for power with a test light or volt meter. If the solenoid is operating properly, the plunger on the solenoid will retract causing a clicking sound. The plunger will also be magnetized which can be checked by touching the plunger with a metal object.

NOTE: Always replace fuse with proper size and type when replacing fuse. Use MDL 10 amp slow blow fuse on front of control console.

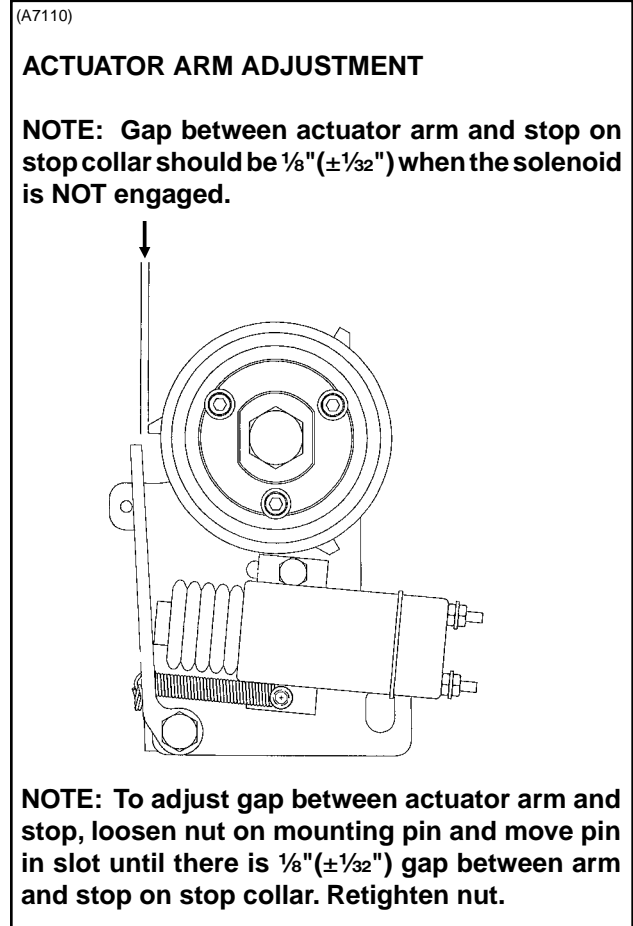
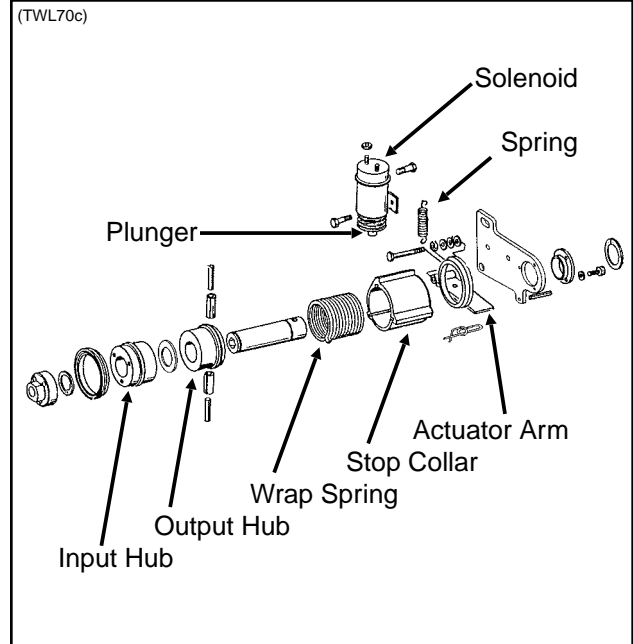

NOTE: To adjust gap between actuator arm and stop, loosen nut on mounting pin and move pin in slot until there is $\frac{1}{8}$ " ($\pm \frac{1}{32}$ ") gap between arm and stop on stop collar. Retighten nut.

MAINTENANCE

POINT ROW CLUTCH TROUBLESHOOTING

PROBLEM	POSSIBLE CAUSE	SOLUTION
None of the clutches will disengage.	Main fuse blown in control console.	Replace defective fuse.
	Poor terminal connection in wiring harness.	Repair or replace.
	Wiring damage in wiring harness.	Repair or replace.
	Low voltage at coil. (12 volts required)	Check battery connections.
One section of planter will not re-engage.	Shear pin at seed drive transmission(s) sheared.	Replace pin with one of equal size and grade.
One clutch will not engage.	Fuses blown.	Replace defective fuses.
	Actuator arm and plunger stuck in disengaged position.	Remove, free up and reinstall.
	Actuator arm out of adjustment.	Adjust actuator arm mounting pin in slot so that actuator arm clears stop on stop collar by approximately 1/8" when clutch is rotated.
	Wrap spring broken or stretched.	Disassemble clutch and replace spring.
	Something touching the stop collar.	Check to ensure collar is free to turn with clutch.
	Clutch assembled incorrectly.	Check clutch and diagram for correct assembly.
Clutch slipping.	Wrap spring stretched.	"Lock" clutch output shaft from turning. Place torque wrench on input shaft and rotate in direction of drive. After input shaft has rotated a short distance the wrap spring should tighten onto the input hub. If slippage occurs at less than 100 ft. lbs. replace spring. If spring still slips after installing new spring, replace input hub.
Planter section will not re-engage while planter is moving forward.	Spring in actuator arm not strong enough to push arm away from stop collar when operational switch is turned to the ON position.	Remove spring from inside solenoid and stretch spring slightly or replace. Reinstall spring. If that fails, file the stop on the stop collar slightly so that the stop is not as aggressive.
Frequent solenoid burnout.	Fuses too large. amp slow blow fuses.	Replace fuses on front panel with 10
Frequent fuse burnout.	Low voltage (12 volts required).	Check power source voltage for partially discharged battery, etc.
	Damage to wiring harness.	Locate damage and repair or replace harness.
Clutch or clutches will not disengage.	Input and output shafts out of alignment.	Align input and output shafts to prevent drag.
	Input or output shaft is pushed in too far creating a coupler.	Reposition input and output shafts.

MAINTENANCE

TWO-SPEED POINT ROW CLUTCHES

The two-speed point row clutch is similar in design and operation to the standard point row clutch except for the two-speed function. If a two-speed clutch or clutches fail to operate properly, refer to "Point Row Clutch Inspection" and "Point Row Clutch Troubleshooting" for additional information.

NOTE: If the "Reduced Rate/Full Rate" functions fail to engage or disengage, see troubleshooting chart for possible cause.

(FF47b)

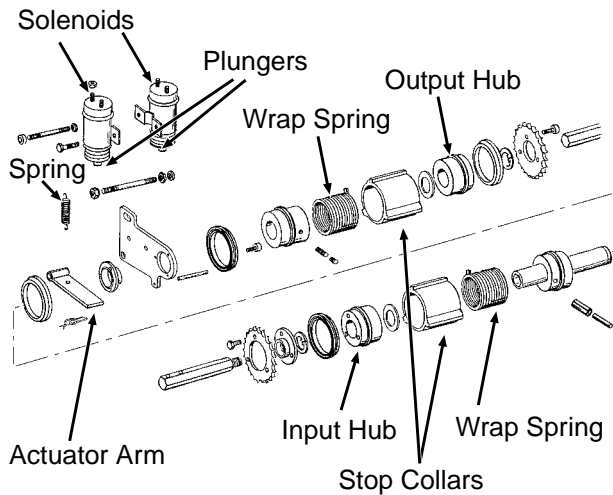

PILOT OPERATED CHECK VALVE INSPECTION (Located In Valve Block On R.H. Side Of Center Pivot)

(TWL30b)

The pilot operated check valve prevents the wing lock cylinders from retracting without applied hydraulic pressure. The wing lock cylinders become the wing flex upper stop during field operation. If the valve fails to function properly, remove the valve from the valve block and check for foreign material or check to see if the o-ring is leaking internally. Replace if found to be defective.

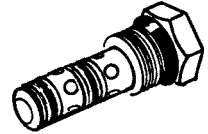

CHECK VALVE (Located In Valve Block On Rear Center Frame)

(TWL30)

The check valves, located in the valve block on the rear side of the center post, trap oil flow in the planter's lift system to keep the toolbar level during field operation. Consult your KINZE® Dealer for service.

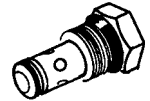

MAINTENANCE

FLOW CONTROL VALVE INSPECTION (Located In Valve Block On Rear Center Frame)

VVB020(TWL28)

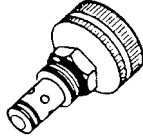

The flow control valves should be adjusted for row marker raise and lower speed as part of the assembly procedure or upon initial operation. If the valve fails to function properly or requires frequent adjustment, it should be removed for inspection. Check for foreign material and contamination on both the valve and the seating area of the valve body. Replace any components found to be defective.

PRESSURE RELIEF VALVE INSPECTION (Located In Valve Block On Hitch)

VVB020(TWL29)

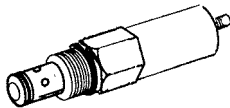

If the pressure relief valve fails to release the tongue lock or function properly, remove the valve from the valve block and check for foreign material or check to see if the o-ring is leaking internally. Replace if found to be defective.

FLOW CONTROL VALVE INSPECTION (Located In Valve Block On Front Center Frame)

(TWL28a)

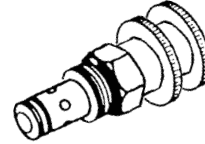

The flow control valve allows auger speed to be varied to meet seed demand. If the valve fails to function properly or requires frequent adjustment, it should be removed for inspection. Check for foreign material and contamination on both the valve and the seating area of the valve body. Replace any components found to be defective.

CHECK VALVE INSPECTION (Located In Valve Block On Front Center Frame)

(TWL24b)

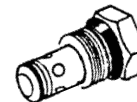

The check valve operates as an in-line check in the return line to prevent reverse operation of the auger system. If the valve fails to function properly, it should be removed for inspection. Check for foreign material or check to see if the o-ring is leaking internally. Replace if found to be defective.

MAINTENANCE

PRESSURE RELIEF VALVE INSPECTION (Located In Valve Block On Front Center Frame)

(TWL24c)

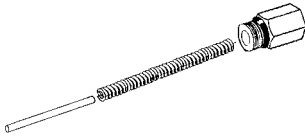

The pressure relief valve limits the applied pressure to the hydraulic auger drive motors to prevent mechanical damage to the motors. If the valve fails to function properly, it should be removed for inspection. Check for foreign material and contamination on both the valve and the seating area of the valve body. Replace any components found to be defective.

SOLENOID VALVE INSPECTION

(PLTR55)

The solenoid valve consists of a chambered body containing a cartridge valve which is activated by an electrical coil.

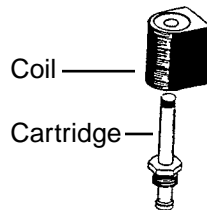

If the solenoid or solenoids fail to operate, first determine if the problem is electrical or hydraulic. If the valve is working properly, a click will be heard when the solenoid coil is energized. This will be the valve stem opening up. If no sound is heard, check the solenoid coil by touching the top of the coil housing with a metallic object such as a pliers or screwdriver. If the coil is working properly, the coil housing will be strongly magnetized when energized. If the voltage to the coil is low, the coil will be weakly magnetized when energized and no click will be heard.

CHECK VALVE INSPECTION (Located In Valve Block Below Vacuum Fan Motor Assembly)

(TWL24b)

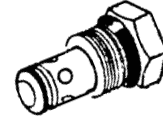

The check valve operates as a check in the return line to prevent reverse operation of the vacuum fan motor. If the valve fails to function properly, it should be removed for inspection. Check for foreign material or check to see if the o-ring is leaking internally. Replace if found to be defective.

RELIEF VALVE CARTRIDGE INSPECTION (Located In Valve Block Below Vacuum Fan Motor Assembly)

(A11340)

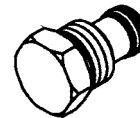

The pressure relief valve helps prevent damage to the vacuum fan motor by limiting pressure in the motor case drain line. It is set to open at 35 PSI. If the valve fails to function properly, it should be removed for inspection. Check for foreign material and contamination on both the valve and the seating area of the valve body. Replace if found to be defective.

NOTE: Case drain pressure will build if the case drain hose to the tractor is connected where pressure is present.

SOLENOID VALVE TROUBLESHOOTING

PROBLEM	POSSIBLE CAUSE	SOLUTION
None of the solenoids will operate.	Low voltage.	Must be connected to 12 volt DC only. Negative ground.
	Blown fuse.	Replace fuse in control console on tractor with AGC-15 amp only.
	Battery connection.	Clean and tighten.
	Wiring harness damaged.	Repair or replace.
One solenoid valve will not operate.	Bad switch.	Replace on control panel.
	Cut wire in harness.	Locate and repair.
	Bad coil.	Replace.
	Poor connection at coil.	Check.
Valve operating when not energized.	Valve stem stuck open.	Replace cartridge.
	O-ring leaking.	Install new O-ring kit.
	Foreign material under poppet.	Remove cartridge and clean.

MAINTENANCE

LIFT CIRCUIT TROUBLESHOOTING

PROBLEM	POSSIBLE CAUSE	SOLUTION
Right wing raises faster than left wing. The right wing may even raise completely before the center frame and left wing start to raise. If the planter is loaded, the center frame and left wing may not be able to raise at all.	Master cylinder, located on front side of center post, leaking internally. NOTE: Make sure the lift system is completely rephased.	Repair or replace master cylinder.
Left wing raises faster than right wing. The left wing may even raise completely before the center frame and right wing start to raise. If the planter is loaded, the center frame and right wing may not be able to raise at all.	Master cylinder, located on rear side of center post, leaking internally. NOTE: Make sure the lift system is completely rephased.	Repair or replace master cylinder.
Center frame will raise, but wings do not.	Planter hydraulic circuit out of phase. Usually occurs when the planter is lowered from transport position.	Hold hydraulic lever in lowering position to give the hydraulic circuit more time to rephase.
Center frame will continue to raise after the wing cylinders have reached full stroke when going to raised field position.	Solenoid valve in port V16 leaking.	Replace solenoid valve cartridge.
Planter will raise to raise field position, but will not raise to transport position.	Solenoid valve coil in port V16 is not energized.	Be sure control console switch is in "raise" position to energize solenoid coil in port V16. Check control console fuse by moving auxiliary switch to ON position. If red light comes on the fuse is OK. Return auxiliary to OFF position. Check for poor wire connection or damaged wire and repair. Solenoid valve coil is defective. All solenoid valves used on the planter are the same. Switch the solenoid coil with one you know is working. If this cures the problem, replace defective coil.
	Solenoid valve cartridge in port V16 is stuck closed.	All solenoid valves used on the planter are the same. Switch the solenoid cartridge with one you know is working. If this cures the problem, replace defective cartridge.
Left wing lowering slower than center frame and right wing. If hydraulic lever is held in lowering position, the left wing cylinder will attempt to extend.	Check valve in port V17 leaking internally.	Remove check valve in port V17 and inspect for foreign material in valve and remove if possible. Replace check valve. If above fails, switch check valve in port V17 with check valve in port V15. If problem moves or switches to right wing, replace defective check valve.

(Continued On Following Page)

MAINTENANCE

LIFT CIRCUIT TROUBLESHOOTING (Continued)

PROBLEM	POSSIBLE CAUSE	SOLUTION
Right wing lowering slower than center frame and left wing. If hydraulic lever is held in lowering position, the right wing cylinder will attempt to extend.	Check valve in port V15 leaking internally.	Remove check valve in port V15 and inspect for foreign material in valve and remove if possible. Replace check valve. If above fails, switch check valve in port V15 with check valve in port V17. If problem moves or switches to right wing, replace defective check valve.
Planter will not raise.	Tractor may have hydraulic problem.	Switch remote outlets being used. Repair tractor hydraulics.
	Planter may be overloaded with hopper extensions and/or extra fertilizer tanks, coulters or non-KINZE® approved attachments.	Remove weight.
	Center pivot wear pads may be adjusted too tight and are now binding on the post.	Adjust pads.
	Relief valves on hitch leaking. Valves should hold 2500 PSI (± 50).	Remove and inspect relief valve cartridge. Check for blown O-rings. Replace bad cartridge.
Planter will not rephase.	Piston seal expanded into barrel rephasing grooves. (Only cylinders with rephasing groove in barrel.) All cylinders not completely retracted. Caused by mechanical interference on or between planter frame and wheel lift module.	Consult your KINZE® Dealer. Remove interference.
	One or more cylinders are completely retracted but not bypassing oil and not allowing remaining cylinders to retract.	Move tractor hydraulic lever to the raise position briefly and down again. Slow down the lowering of the planter from the raised transport position to the planting position. This will slow the flow of oil that passes by the rephasing groove in the wing cylinders.
	Lift cylinder counter balance valve pilot pressure set too high.	Adjust pilot pressure on valve. Turn screw clockwise to reduce setting and release load. Complete adjustment range is 3 turns.

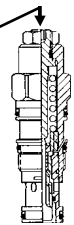

MAINTENANCE

TONGUE CYLINDER CIRCUIT TROUBLESHOOTING

PROBLEM	POSSIBLE CAUSE	SOLUTION
Tongue cylinder will not extend, but will retract.	No power to solenoid valve coil in port V10 and/or V14. Both must be energized.	Check wiring between control console and solenoid coils looking for damaged wires and poor connections.
	Solenoid valve coil defective.	Switch coil from port V13 with V10. If tongue still will not extend, switch coil from V14 with V13. It will not be necessary to remove any of the wire connections to the solenoid. All three of these solenoids are normally energized when the tongue switch is energized. Replace defective coil.
	Solenoid valve cartridges in port V10 and/or V14 stuck closed.	Switch cartridge from port V10 with cartridge in port V13. If tongue cylinder retracts, replace defective cartridge from port V10. If problem continues, switch cartridge from port V14 with cartridge in port V13. Replace defective cartridge.
Tongue cylinder will not extend but tongue lock cylinder extends.	Pressure relief valve in port V11 stuck closed or pressure setting too high. (Valve is factory set to open at 1000 PSI.)	Replace or adjust pressure relief valve. To adjust, loosen lock nut and turn counterclockwise to decrease pressure.
Tongue hook does not release before the tongue starts to extend.	Solenoid valve cartridge in port V11 stuck open or pressure setting too low. (Valve is factory set to open at 1000 PSI.)	Replace or adjust pressure relief valve. To adjust, loosen lock nut and turn clockwise to increase pressure.
Tongue cylinder will not retract, but will extend.	Solenoid valve coil in port V13 defective.	Switch coil from port V13 with coil from port V14. If coil from port V13 is bad, the tongue will extend but not retract. Replace defective coil.
	Solenoid valve cartridge in port V13 stuck closed.	Switch cartridge from port V13 with cartridge from port V14. If cartridge is bad, the tongue will extend but not retract. Replace defective cartridge.
Tongue extends with the switch off.	Solenoid valve cartridge in port V10 and V14 stuck open.	Replace solenoid valve cartridge.
Tongue retracts with the switch off.	Solenoid valve cartridge in port V13 stuck open.	Replace solenoid valve cartridge.

MAINTENANCE

ROTATION CYLINDER CIRCUIT TROUBLESHOOTING

PROBLEM	POSSIBLE CAUSE	SOLUTION
Cylinder does not extend, but will retract.	Solenoid valve coil in port V12 defective.	Switch coil from port V12 with coil in port V9. If cylinder extends but will not retract, replace defective coil from port V12.
	Solenoid valve cartridge in port V12 is stuck closed.	Switch cartridge from port V12 with cartridge in port V9. If cylinder extends but will not retract, replace defective cartridge from port V12.
Cylinder does not retract, but will extend.	Solenoid valve coil in port V9 defective.	Switch coil from port V9 with coil in port V12. If cylinder extends but will not retract, replace defective coil from port V9. Switch cartridge from port V9 with
	Solenoid valve cartridge in port V9 is stuck closed.	cartridge in port V12. If cylinder extends but will not retract, replace defective cartridge from port V9.

MAINTENANCE

WING LOCK CYLINDER CIRCUIT TROUBLESHOOTING

PROBLEM	POSSIBLE CAUSE	SOLUTION
Cylinders will not extend or retract.	No power to the solenoid valve coils.	Auxiliary switch may be in the ON position. Must be in OFF position. Check fuse at control console. Replace fuse with 15 amp type AGC if blown. Check for poor wire connection or damaged wire. Repair as required.
Cylinders will not extend.	Solenoid valve coil in port V4 not energized.	Check for power to coil. Check coil ground wire. If OK, switch coil from port V3 with coil from port V4. If cylinders extend but will not retract, replace defective coil.
	Solenoid valve cartridge in port V4 stuck closed.	Switch cartridge in port V3 with cartridge in port V4. If cylinders extend but will not retract, replace defective cartridge.
	Pilot pressure on counter balance valve port S1 set too high.	*Adjust pilot pressure on valve. Turn screw clockwise to reduce setting and release load. Complete adjustment range is 3 turns.
Cylinders will not retract.	Solenoid valve coil in port V3 not energized.	Check for power to coil. Check coil ground wire. If OK, switch coil from port V4 with coil from port V3. If cylinders retract but will not extend, replace defective coil.
	Solenoid valve cartridge in port V3 stuck closed.	Switch cartridge in port V4 with cartridge in port V3. If cylinders retract but will not extend, replace defective cartridge.
	Pilot operated check valve in port D10 stuck closed.	Replace pilot operated check valve.
Cylinders retract with the switch off.	Solenoid valve cartridge in port V3 stuck open.	Replace solenoid valve cartridge.
Cylinders extend with the switch off.	Solenoid valve cartridge in port V4 stuck open.	Replace solenoid valve cartridge.
Cylinder leaks down. Will not hold weight of wing in transport.	Counter balance valve leaking or stuck open.	*Switch valves with another cylinder. If this resolves the problem, replace defective valve. If it does not, check for internal leak in cylinder.

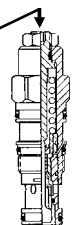

*Adjustment or replacement to wing cylinder counter balance valves should be made with the planter lowered to planting position, tractor off and system hydraulic pressure relieved.

MAINTENANCE

ROW MARKER OPERATION TROUBLESHOOTING

PROBLEM	POSSIBLE CAUSE	SOLUTION
Right marker lowering slower than left marker.	Solenoid valve cartridge in port V1 not opening completely.	Switch cartridge with one in port V2. If problem follows cartridge, replace cartridge.
	Hose pinched or collapsed.	Inspect hose routing. Replace or repair hoses as required.
Left marker lowering slower than right marker.	Solenoid valve cartridge in port V2 not opening completely.	Switch cartridge with one in port V1. If problem follows cartridge, replace cartridge.
	Hose pinched or collapsed.	Inspect hose routing. Replace or repair hoses as required.
Both markers lowering.	Solenoid valve cartridge stuck open. If marker switch is in the left marker position, the right cartridge (V1) is defective. If the marker switch is in the right marker position, the left cartridge (V2) is defective.	Replace solenoid valve cartridge.
Neither marker will lower.	Blown fuse.	Check red light on control console. It should be on if switch is on. If light is not on, switch to opposite marker position. If light comes on, switch may be defective. Replace switch. Otherwise replace fuse.
	Coils at V1 and V2 not energized.	Poor ground on wire, bad wire connection or damaged wire. Repair as required.
	Marker flow control valve closed too far.	See Operation section for adjustment.
Neither marker will raise.	Marker flow control valve closed too far.	See Operation section for adjustment.
Right marker will not lower.	Solenoid coil in port V1 not energized.	Check switch on control console. Replace if defective. Check coil ground wire. Check for poor connection or damaged wire.
	Solenoid cartridge in port V1 stuck closed.	Switch cartridge with one on the planter you know is operating properly. If right marker lowers, replace defective cartridge.
Left marker will not lower.	Solenoid coil in port V2 not energized.	Check switch on control console. Replace if defective. Check coil ground wire. Check for poor connection or damaged wire.
	Solenoid cartridge in port V2 stuck closed.	Switch cartridge with one on the planter you know is operating properly. If left marker lowers, replace defective cartridge.
Markers traveling too fast and damaging rubber stop on transport stands and/or damaging pivot at rod end of marker cylinders.	Marker transport stand not adjusted correctly to allow marker cushion cylinders to operate as designed.	See "Row Marker Transport Stand Adjustment".
	Marker flow control valve out of adjustment.	See Operation section for adjustment.

MAINTENANCE

ROW MARKER TRANSPORT STAND ADJUSTMENT

It is critical that the row marker transport stands are adjusted correctly to allow the row marker cushion cylinders to function properly.

To adjust the transport stands:

1. Fold row markers to transport position.
2. Loosen mounting hardware to allow transport stands to drop down or remove transport stands.
3. With tractor engine shut off, release hydraulic pressure on marker cylinders.
4. Locate transport stands so marker arm rests lightly on transport stand. When the transport stands are correctly adjusted the pin at the rod end of the cylinder should be loose enough to rotate and move back and forth in the mounting slot.
5. Torque mounting hardware.

(TWL200a)

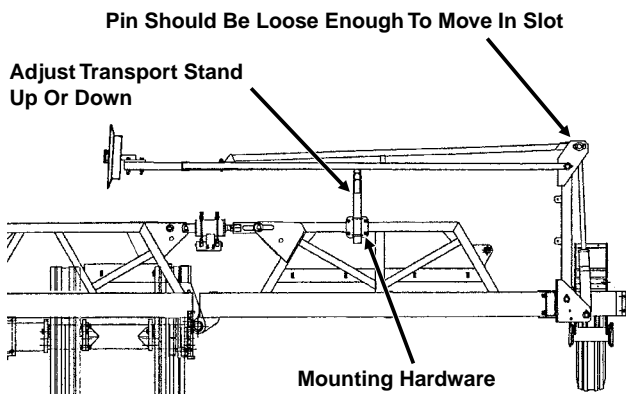

ROW MARKER BEARING LUBRICATION OR REPLACEMENT

1. Remove row marker blade.
2. Remove dust cap from hub.
3. Remove cotter pin, nut and washer.
4. Slide hub from spindle.
5. Remove bearings and cups and discard if bearings are being replaced. Clean hub and dry. Remove bearings only and not cups if repacking.
6. Press in new bearing cups with thickest edge facing in. (Bearing replacement procedure only.)
7. Pack bearings with heavy duty wheel bearing grease thoroughly forcing grease between roller cone and bearing cage. Also fill the space between the bearing cups in the hub with grease.
8. Install rubber seal into grease seal. Place inner bearing in place and press in new rubber seal/grease seal.
9. Clean spindle and install hub.
10. Install outer bearing, washer and slotted hex nut. Tighten slotted hex nut while rotating hub until there is some drag. This assures that all bearing surfaces are in contact. Back off slotted nut to nearest locking slot and install cotter pin.
11. Fill dust caps approximately $\frac{3}{4}$ full of wheel bearing grease and install on hub.
12. Install blade and dust cap retainer on hub and tighten evenly and securely.

(PLTR45/PLTR99/PLTR98/PLTR102)

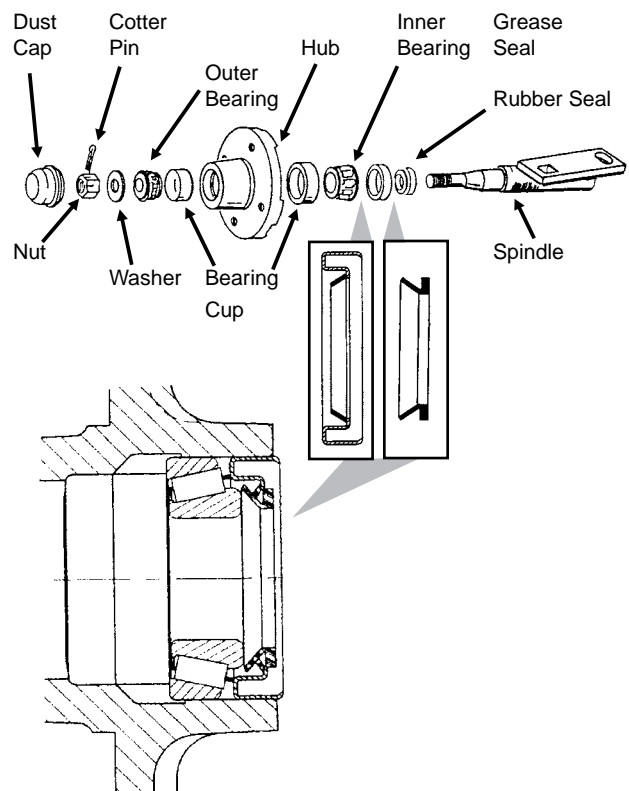

MAINTENANCE

WHEEL BEARING LUBRICATION OR REPLACEMENT

NOTE: Each transport wheel hub is equipped with a grease fitting for lubrication. The below procedure is used only for bearing replacement.

1. Raise tire clear of ground and remove wheel.
2. Remove double jam nuts and slide hub from spindle.
3. Remove bearings, seals (Where Applicable) and cups and discard if bearings are being replaced. Clean hub and dry. Remove bearings only and not cups if repacking.
4. Press in new bearing cups with thickest edge facing in. (Bearing replacement procedure only.)
5. Pack bearings with heavy duty wheel bearing grease thoroughly forcing grease between roller cone and bearing cage. Also fill the space between the bearing cups in the hub with grease.
6. Place inner bearing and seal (Where Applicable) in place.
7. Clean spindle and install hub.
8. Install outer bearing, seal (Where Applicable) and stepped nut. Tighten jam nut while rotating hub until there is some drag. This assures that all bearing surfaces are in contact. Back off jam nut $\frac{1}{4}$ turn or until there is only slight drag when rotating the hub. Install second jam nut to lock against first.
9. Install wheel on hub and tighten evenly and securely. Torque wheel bolts to specified torque.

(EF35e)

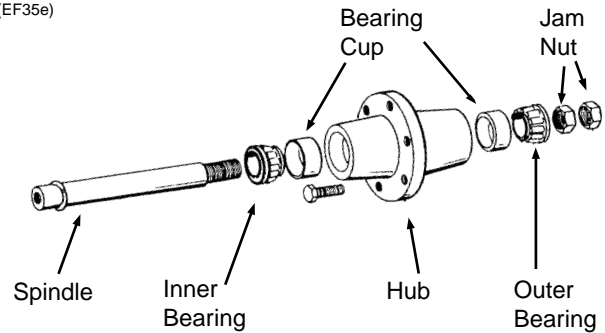

HTA029(PLTR56)

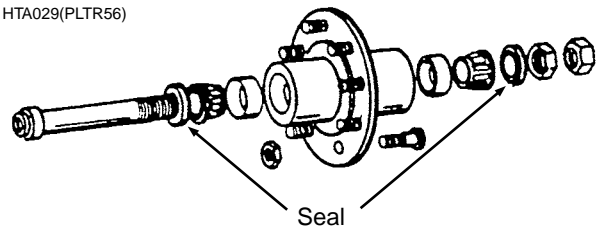

MAINTENANCE

WEAR PAD REPLACEMENT AND ADJUSTMENT

(TWL193c)

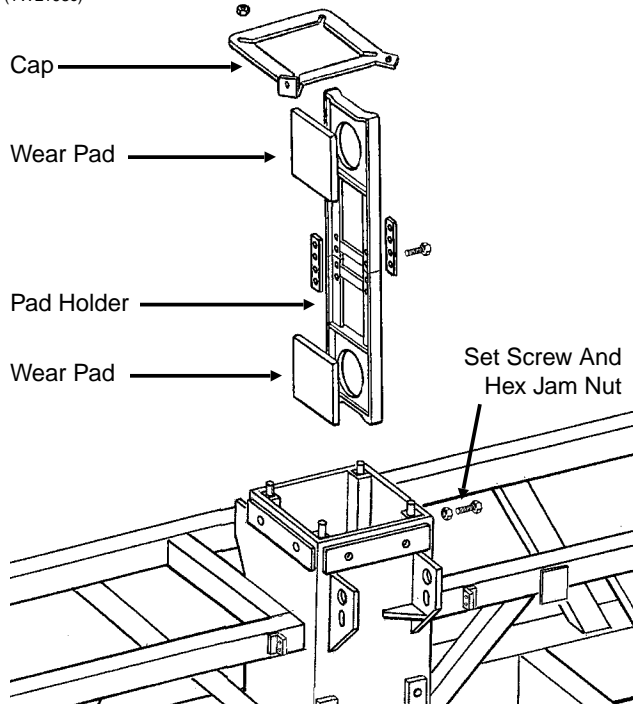

The center section of the planter is constructed around a steel tubular frame with four wear pad assemblies that ride against a stainless steel clad center post. Each wear pad assembly includes a pad holder and two wear pads. The wear pads are held by the pad holder and locked in place by $\frac{3}{4}$ " set screws and hex jam nuts.

Inspect for wear and check pad adjustment annually to ensure the center section is stabilized and the planter tracks properly. Replace any broken or missing adjustment set screws. When properly adjusted the pads should make full contact with the center post with light contact. Too much preload on the pads will cause the hydraulic lift pressure to be higher than necessary or will not allow the planter to raise when the planter is loaded.



WARNING: Always install all safety lockup devices before working under the unit.

To check adjustment and wear, position the planter on a level surface. Raise the planter to the raised field position. Visually check the four upper wear pads. Each wear pad should lightly contact the stainless steel clad center post. The maximum allowable gap between the plastic wear pad and the stainless steel post, when checked using a thickness gauge, should be no more than .060". Raise the planter to the raised transport position, install all safety lockups and visually check the four lower wear pads. Maximum allowable gap on the lower pads is .060".

(TWL109b)

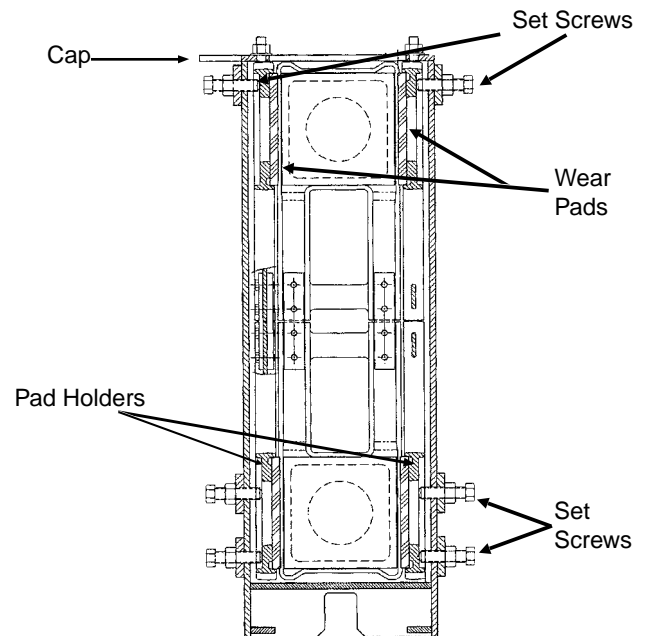

If adjustment is necessary proceed as follows: (a) Lower the planter to field operation position. It may be necessary to the loosen cap mounting nuts to allow wear pad adjustment. (b) Loosen the necessary hex jam nuts. (c) Tighten set screws until the wear pad lightly contacts the stainless steel clad center post. **DO NOT OVER TIGHTEN.** (d) Tighten hex jam nuts. (e) Recheck clearance. If clearance is not to specifications, repeat adjustment steps. (f) Torque hex jam nuts to 200 ft. lbs. Tighten cap mounting bolts if applicable.

NOTE: If exposed portion of wear pad is worn to less than $\frac{1}{8}$ " as shown below, replace the wear pad.

(TWL149a)

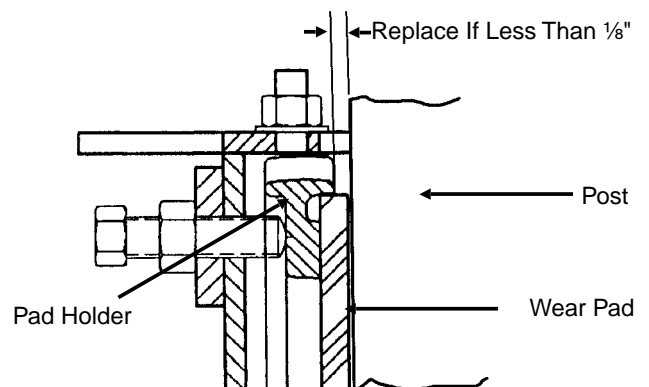

MAINTENANCE

If major adjustment or replacement is necessary proceed as follows: (a) Loosen cam rollers as shown below so they move freely. (b) Lower the planter to field operation position and release wing locks. (c) Eliminate all uplift on planter frame by backing off row unit down pressure springs and uplift on any other planter attachments.

D01190716

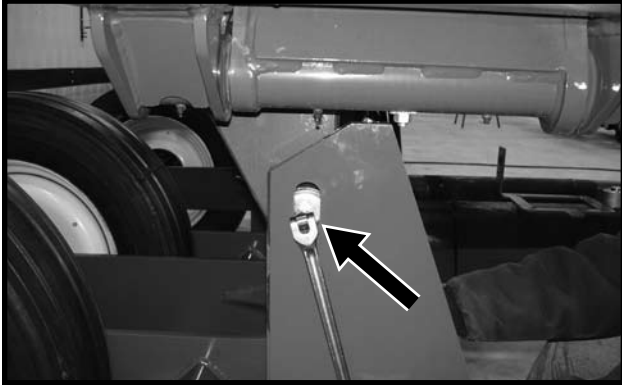

For pad adjustment only (d) Check position of center frame to axle cam roller guides. Gap between guides and frame should be the same side to side. Gap on the back sides of the roller guide should be equal on both sides. Final adjustment will be done later. (e) Loosen the four cap mounting nuts as shown below. (f) Loosen the hex jam nuts and use the pad set screws to position the frame to center correctly. (g) To adjust the pads, the pad set screws should be drawn tight, backed off and turned in until there is light contact with the pad holder. (h) Tighten hex jam nuts. (i) Torque hex jam nuts to 200 ft. lbs. (g) Tighten cap mounting nuts. (h) Reset row unit down pressure and other attachments from STEP c.

IMPORTANT: DO NOT OVERTIGHTEN WEAR PADS. OVERTIGHTENING WILL CAUSE PREMATURE WEAR AND EXCESSIVE HYDRAULIC LIFT PRESSURES.

D01190745

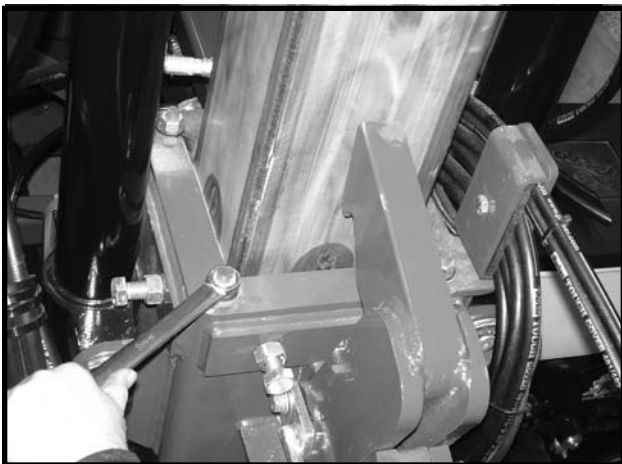

For pad replacement (d) As shown below, remove safety hook, disconnect hydraulic hose, remove nut on bulkhead fitting and remove fitting from cap..

D01190729

D01190725

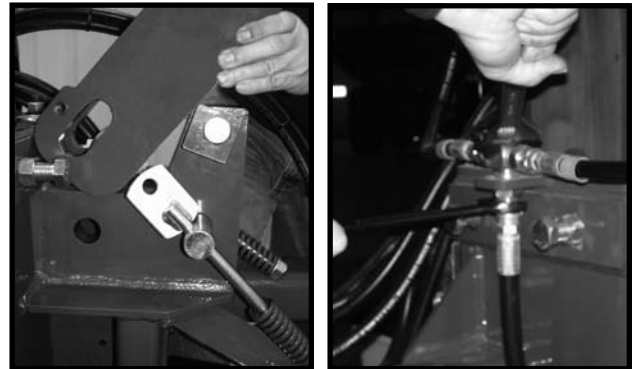

(e) Loosen the four cap mounting nuts and remove pad holder cap. (f) Loosen the pad hex jam nuts, back the pad screws out and remove the four pad holder assemblies as shown below.

D01190737



(g) Remove old pads and install new pads. NOTE: Apply a small amount of weather stripping adhesive to hold the pads in place while the pad holder is being reinstalled.

D01190739

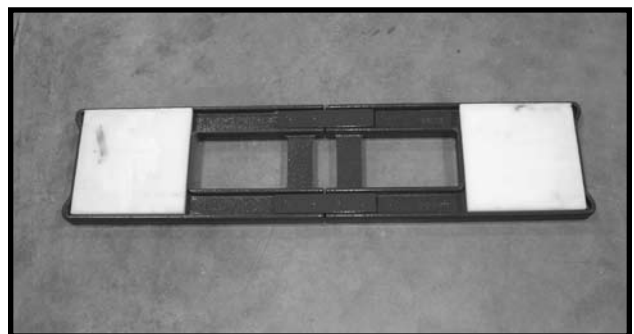

MAINTENANCE

(h) To adjust the pads, the pad set screws should be drawn tight, backed off and turned in until there is light contact with the pad holder. (i) Tighten hex jam nuts. (j) Torque hex jam nuts to 200 ft. lbs.

IMPORTANT: DO NOT OVERTIGHTEN WEAR PADS. OVER TIGHTENING WILL CAUSE PREMATURE WEAR AND EXCESSIVE HYDRAULIC LIFT PRESSURES.

(k) Reinstall cap and tighten cap mounting nuts. (l) Reinstall hydraulic hose, fittings and safety hook.

D01190744



(m) Adjust stop on safety hook. Maximum clearance should be $\frac{1}{2}$ " and minimum clearance $\frac{1}{8}$ " as shown above.

D01190727

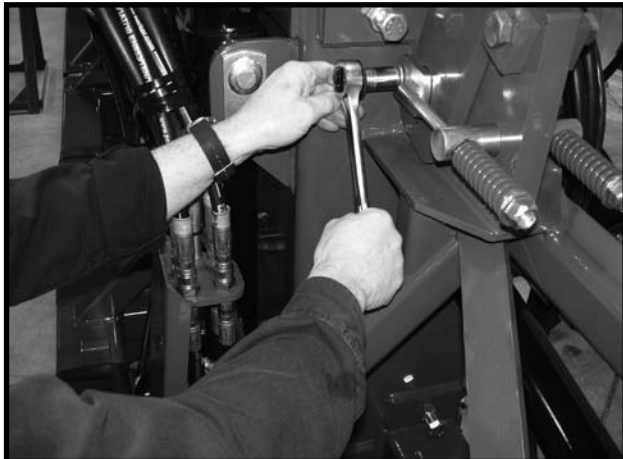

(n) Rotate cam roller against front guide and tighten to 200 ft. lbs. Make sure gap between roller guide and center frame are equal on both sides. (o) Raise planter out of the roller guides and lower back down into roller guides to be sure the roller guides operate smoothly. If not, adjust the rotation cylinder rod as shown below.

D01190731



D01190732

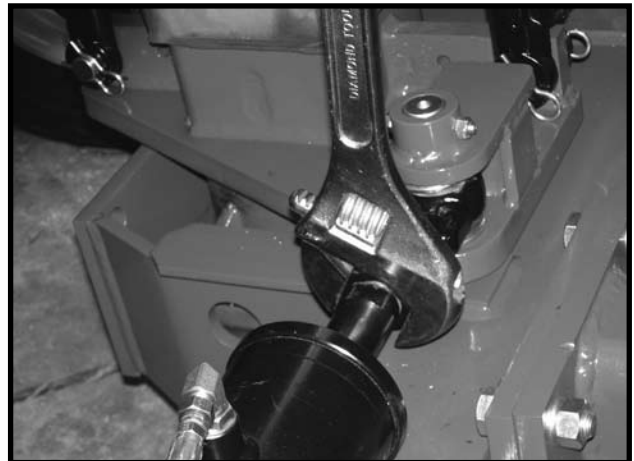

(p) Reset row unit down pressure and other attachments from STEP c.

MAINTENANCE

PISTON PUMP STORAGE

IMPORTANT: KEEP AIR OUT OF PUMP! This is the only way to prevent corrosion. Even for short periods of storage, the entrance of air into the pump, will cause **RAPID AND SEVERE CORROSION**.

Overnight Storage

SUSPENSION FERTILIZER must be flushed from the pump for ANY storage period.

Winter Storage

1. Flush pump thoroughly with 5 to 10 gallons of fresh water and circulate until all corrosive salts are dissolved in the pump.
2. With the pump set on 10, draw in a mixture of half diesel fuel and half 10 weight oil until the discharge is clean. Then plug inlet and outlet.

D071504102a

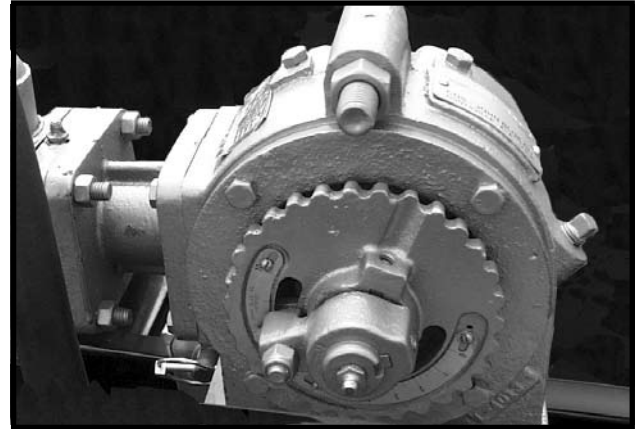

(A12330a)

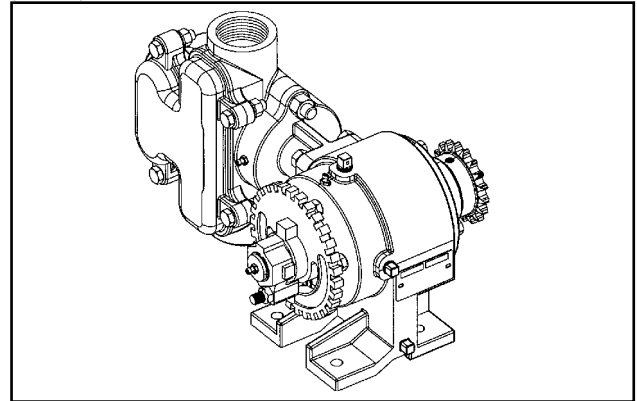

PISTON PUMP TROUBLESHOOTING

PROBLEM	POSSIBLE CAUSE	SOLUTION
Pump hard or impossible to prime.	Valves fouled or in wrong place.	Inspect and clean valves.
	Air leak in suction line.	Repair leak.
	Pump set too low.	Adjust pump setting.
	Packing washers worn out.	Replace.
Low metering.	Valves fouled or in wrong place.	Inspect and clean valves.
	Air leak in suction line.	Repair leak.
	Pump set too low.	Adjust pump setting.
	Broken valve spring.	Replace spring.
Over meters.	Broken discharge valve spring.	Replace spring.
	Trash under valves.	Inspect and clean valves.
	Improper rate setting.	Adjust pump setting.
Leaks through when stopped.	Broken discharge valve spring.	Replace spring.
	Trash under valves.	Inspect and clean valves.
Fertilizer solution leaking under stuffing box.	Packing washers worn out.	Replace.
Pump using excessive oil.	Oil seals or O-ring worn and leaking.	Replace.
Pump operates noisily.	Crankcase components worn excessively.	Inspect and replace if necessary.

MAINTENANCE

PREPARATION FOR STORAGE

Store the planter in a dry sheltered area if possible.

Remove all trash that may be wrapped on sprockets or shafts and remove dirt that can draw and hold moisture.

Clean all drive chains and coat with a rust preventative spray, or remove chains and submerge in oil.

Lubricate planter and row units at all lubrication points.

Inspect the planter for parts that are in need of replacement and order during the "off" season.

Make sure all seed and granular chemical hoppers are empty and clean.

Remove seed discs from seed meters, clean and store meters in a rodent-free, dry area with discs removed. Store seed discs vertically on a dowel or pipe.

Remove vacuum hose from the each seed meter. Operate the vacuum fan at full hydraulic flow from the tractor for two minutes to clear manifolds, hoses and fittings of dust and debris.

Clean breather on analog vacuum gauge.

Grease or paint disc openers/blades and row marker disc blades to prevent rust.

Flush liquid fertilizer tanks, hoses and metering pump with clean water. See "Piston Pump Storage" if applicable.

Disengage row unit clutch and unlatch mini-hopper on each row unit to release stress on drop hoses during storage. (SDS Only).

ELECTRICAL WIRING DIAGRAM FOR LIGHT PACKAGE

(WGN66a)

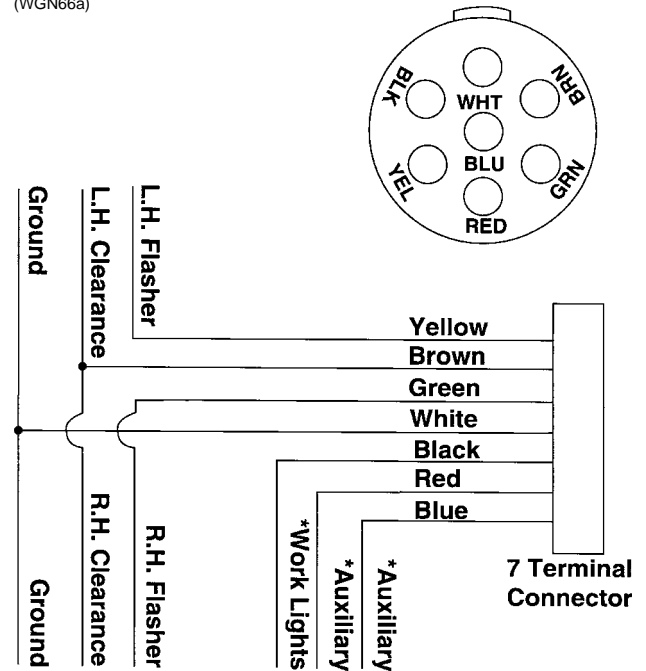

* Optional customer-supplied auxiliary lights and wires may be wired into existing plug terminals.

The light package supplied on the Model 3650 Twin-Line® Planter meets ASAE Standards. For the correct wiring harness to be wired into the lights on your tractor, check with the tractor manufacturer.

69922-35



MAINTENANCE

ELECTRICAL CONTROL CONSOLE SCHEMATIC (3650 Conventional)

IMPORTANT: Before doing any electrical work, disconnect the control console from the tractor battery. Keep wiring harnesses away from high temperature areas or sharp edges. DO NOT route the wiring harnesses along battery cables. Use tie straps to keep wire harness away from moving parts on tractor and planter. Be sure ground connections to the tractor frame are clean to provide good electrical contact.

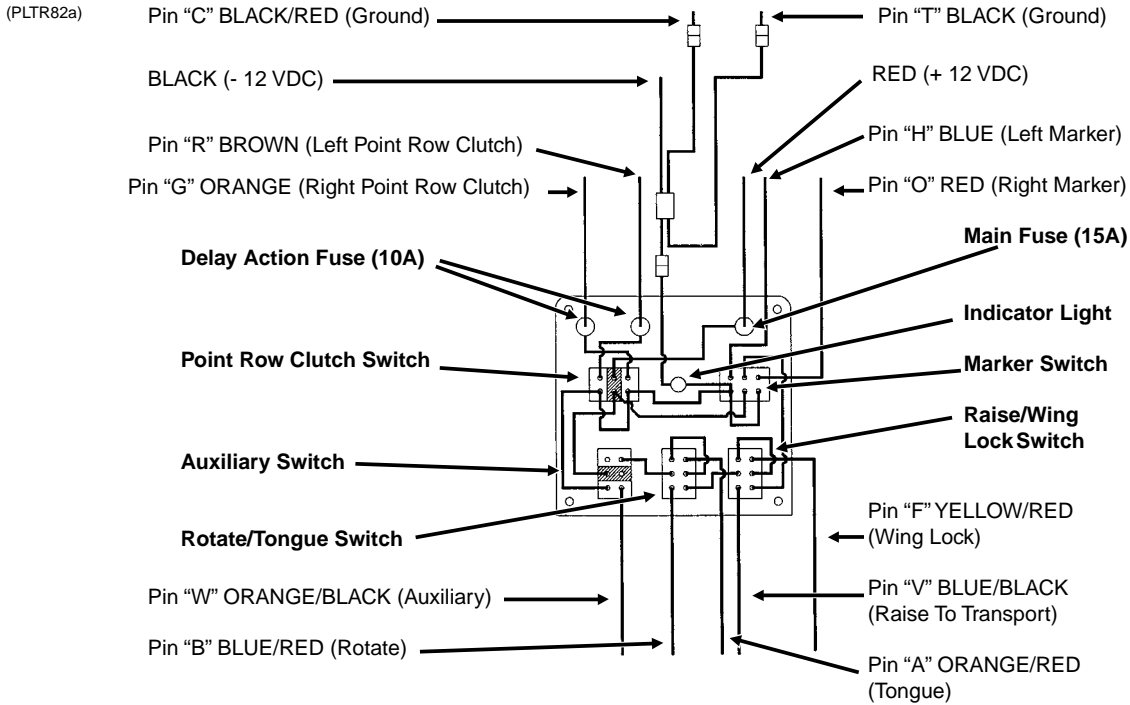

(INS238)

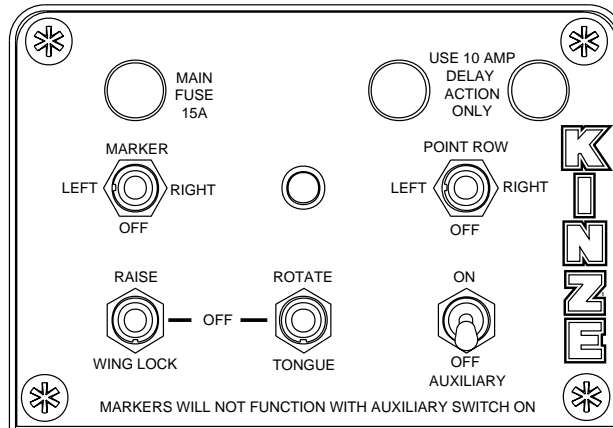

NOTE:

1. Operating marker or point row switch in either direction lights panel light.
2. Point row clutch switch operates independently of the rest of the control box.
3. Power to the marker switch is fed through the auxiliary switch and the two transport function switches. Operating any of the switches in the lower row disables the marker function and turns off the panel light. (If the point row clutch switch is in the "off" position.)

See pages 11-41 And 11-42 for electrical control console schematic and wiring harness to two-speed point row clutch solenoids for planter equipped with the optional Two-Speed Point Row Clutch Package.

MAINTENANCE

ELECTRICAL CONTROL CONSOLE SCHEMATIC (3650 SDS)

IMPORTANT: Before doing any electrical work, disconnect the control console from the tractor battery. Keep wiring harnesses away from high temperature areas or sharp edges. DO NOT route the wiring harnesses along battery cables. Use tie straps to keep wire harness away from moving parts on tractor and planter. Be sure ground connections to the tractor frame are clean to provide good electrical contact.

(A10189a)

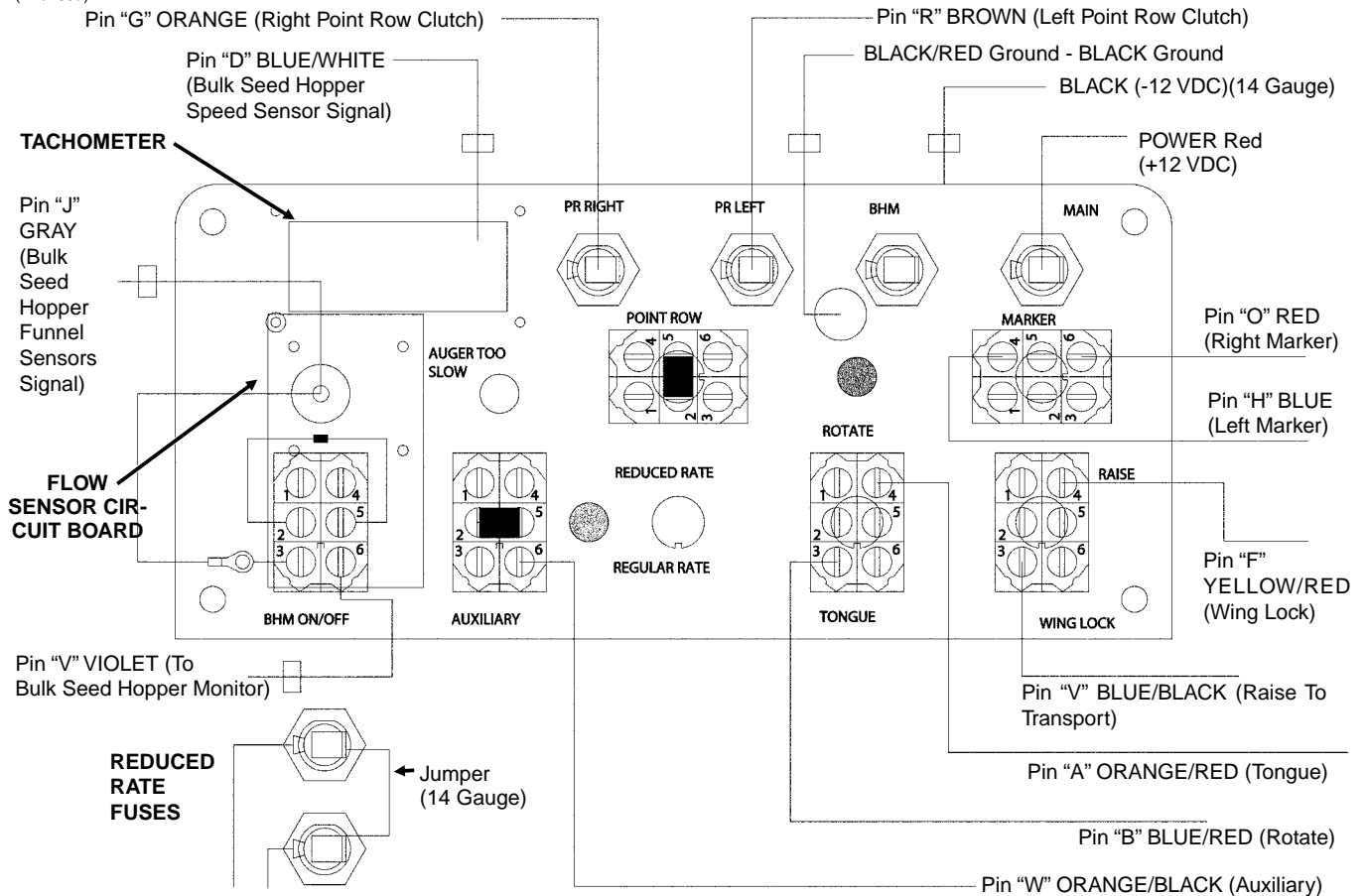

(A10189b)

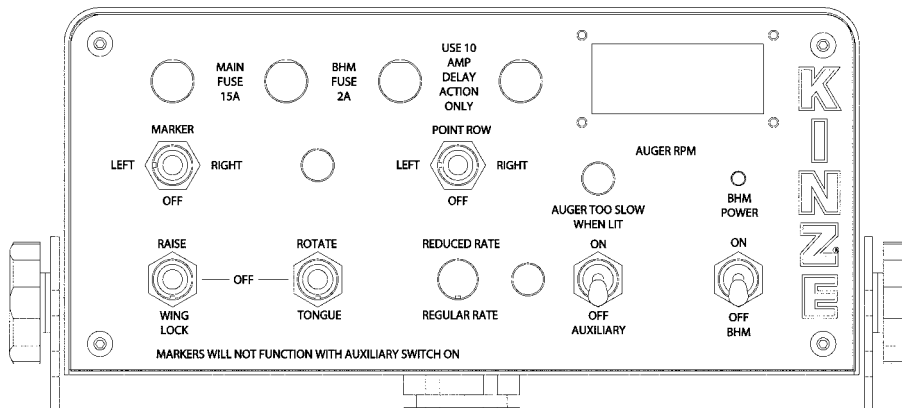

NOTE:

1. Operating marker or point row switch in either direction lights panel light.
2. Point row clutch switch operates independently of the rest of the control box.
3. Power to the marker switch is fed through the auxiliary switch and the two transport function switches. Operating any of the switches in the lower row disables the marker function and turns off the panel light. (If the point row clutch switch is in the "off" position.)

See pages 11-41 and 11-42 for electrical control console schematic and wiring harness to two-speed point row clutch solenoids for planter equipped with the optional Two-Speed Point Row Clutch Package.

MAINTENANCE

ELECTRICAL WIRING HARNESS SCHEMATIC (On Tractor - 3650 Conventional)

(ELC10c/ELC13)

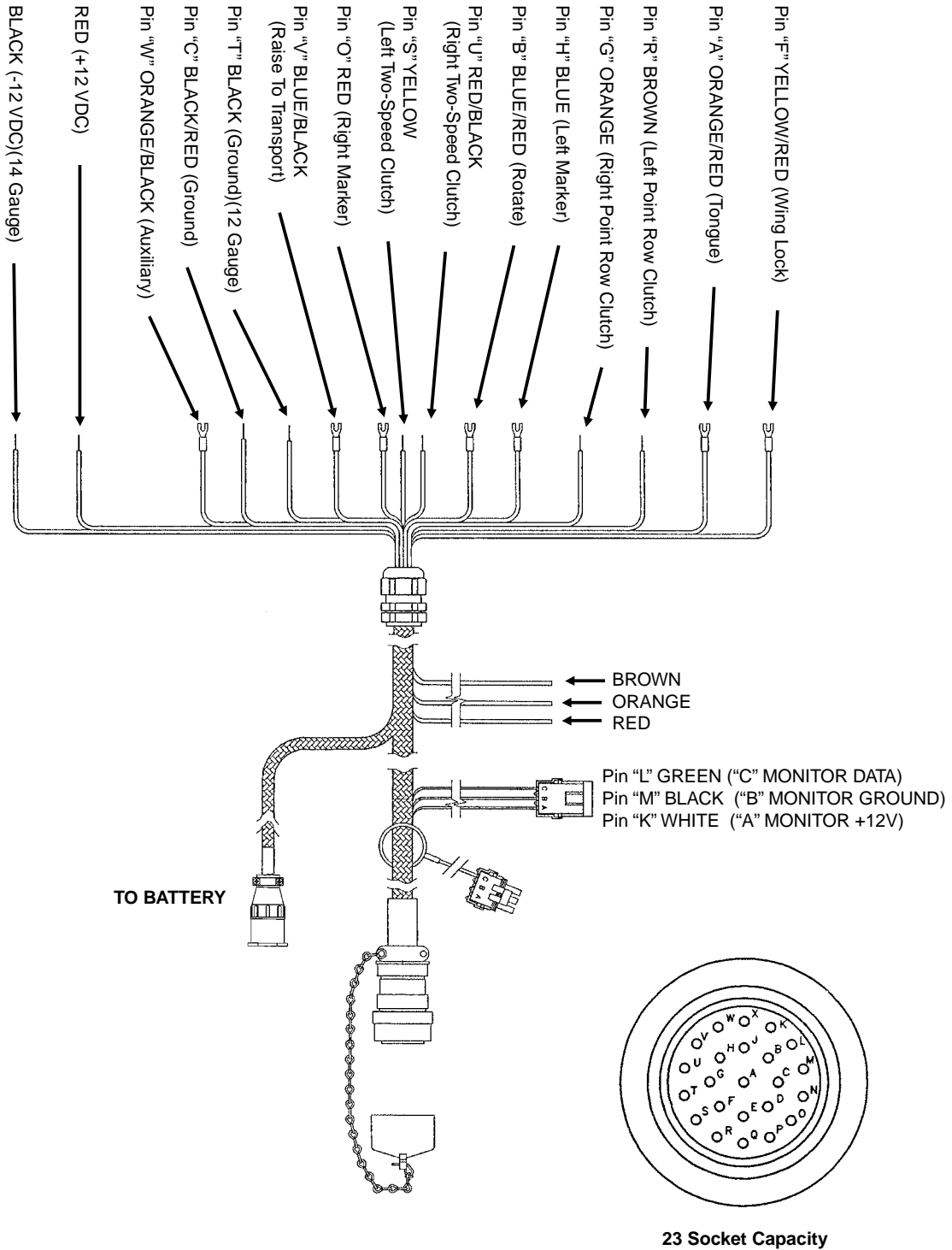

MAINTENANCE

ELECTRICAL WIRING HARNESS SCHEMATIC (On Tractor - 3650 SDS)

(ELC10d/ELC13)

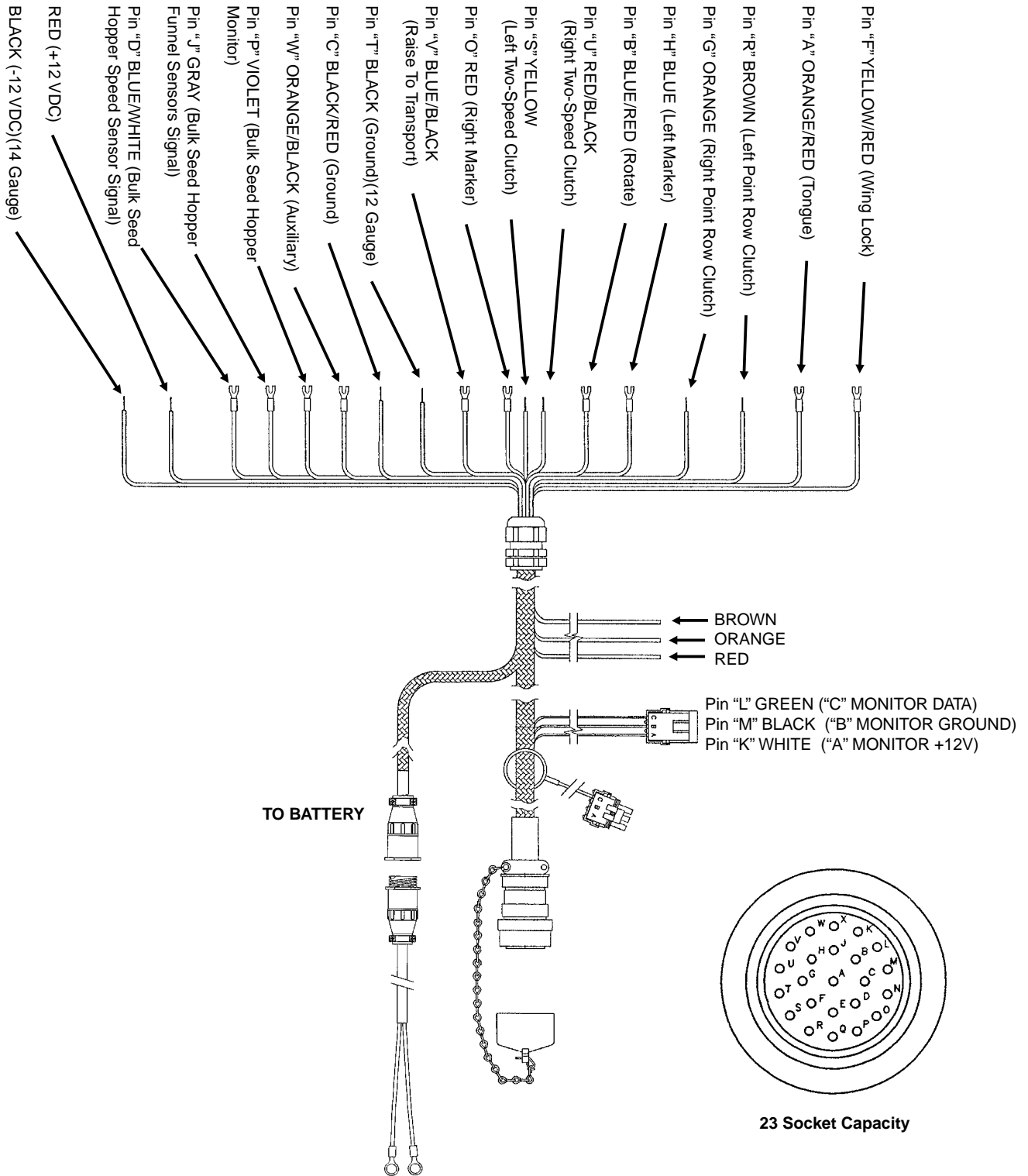

MAINTENANCE

ELECTRICAL WIRING HARNESS SCHEMATIC (On Planter)

(ELC13/A10101a/TWL71b)

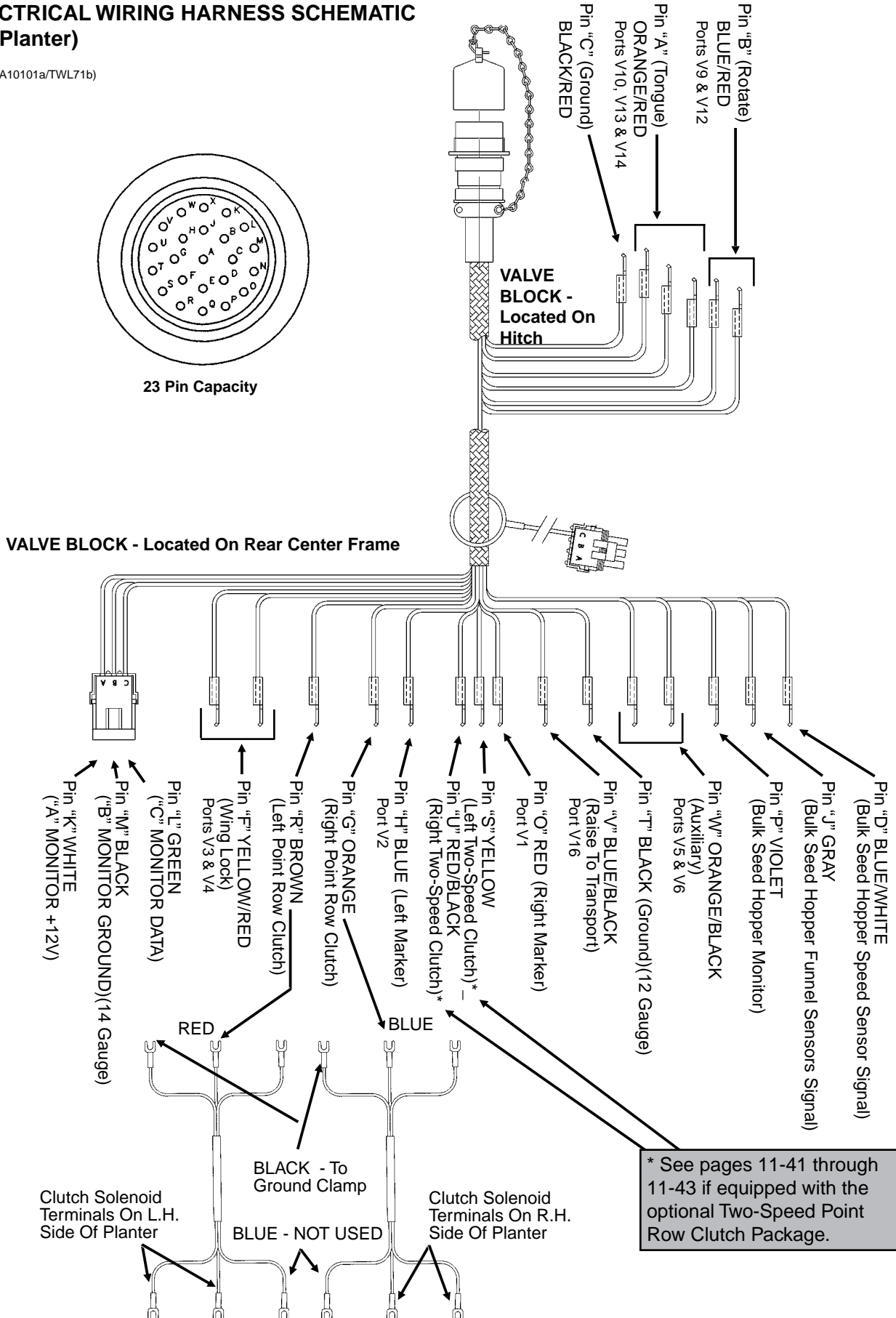

MAINTENANCE

(A7012a)

VALVE BLOCK - Located On Hitch

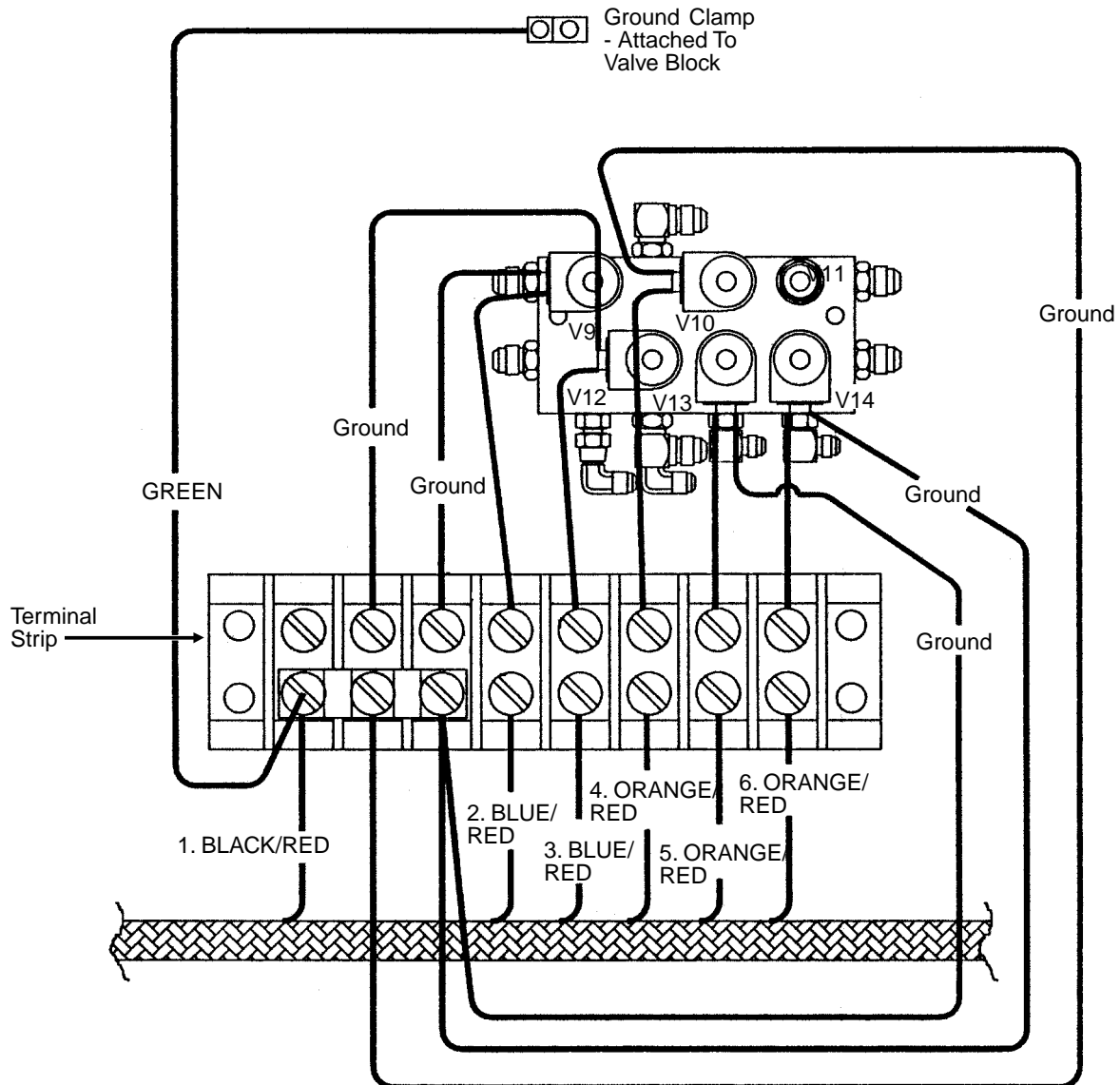

1. BLACK/RED - Pin "C" (Ground)
2. BLUE/RED - Pin "B" (Rotate) - Port V9
3. BLUE/RED - Pin "B" (Rotate) - Port V12
4. ORANGE/RED - Pin "A" (Tongue) - Port V10
5. ORANGE/RED - Pin "A" (Tongue) - Port V13
6. ORANGE/RED - Pin "A" (Tongue) - Port V14

MAINTENANCE

(A7102a)

VALVE BLOCK - Located On Rear Center Frame

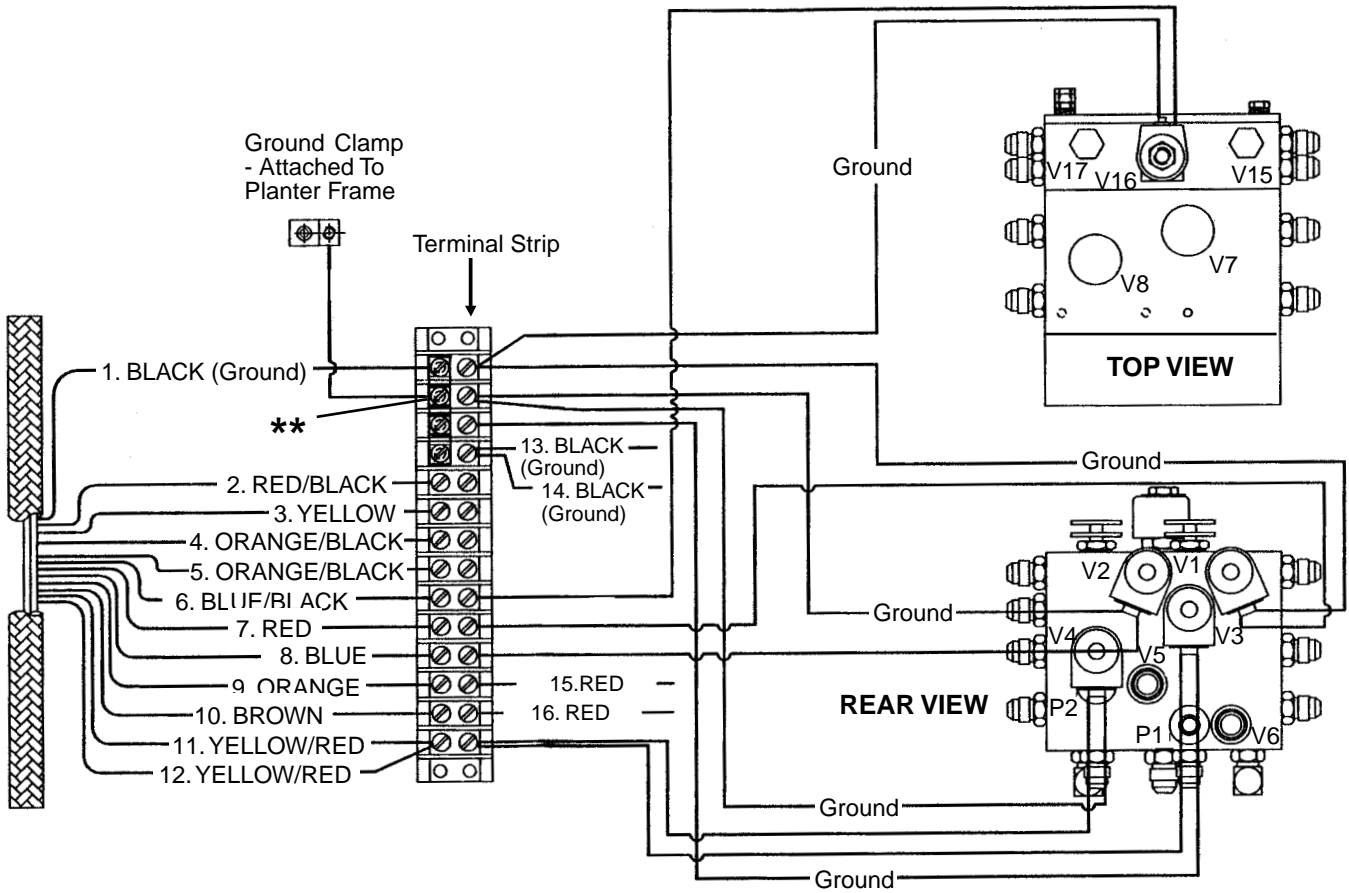

1. BLACK - Pin "T" (Ground)
2. RED/BLACK - Pin "U" (Right Two-Speed Clutch)*
3. YELLOW - Pin "S" (Left Two-Speed Clutch)*
4. ORANGE/BLACK - Pin "W" (Auxiliary) - Ports V5 & V6
5. ORANGE/BLACK - Pin "W" (Auxiliary) - Ports V5 & V6
6. BLUE/BLACK - Pin "V" (Raise To Transport) - Port V16
7. RED - Pin "O" (Right Marker) - Port V1
8. BLUE - Pin "H" (Left Marker) - Port V2
9. ORANGE - Pin "G" (Right Point Row Clutch)
10. BROWN - Pin "R" (Left Point Row Clutch)
11. YELLOW/RED - Pin "F" (Wing Lock) - Ports V3 & V4
12. YELLOW/RED - Pin "F" (Wing Lock) - Ports V3 & V4
13. BLACK - (R.H. Point Row Ground)
14. BLACK - (L.H. Point Row Ground)
15. RED - (R.H. Point Row)
16. RED - (L.H. Point Row)

* See pages 11-41 through 11-43 if equipped with the optional Two-Speed Point Row Clutch Package.

** 3650 SDS Only - Jumper wire to terminal strip on rear center frame valve block cover.

MAINTENANCE

BULK SEED HOPPER MONITOR SYSTEM WIRING SCHEMATIC (3650 SDS Only)

(ELC43)

TERMINAL STRIP - Located On Rear Center Frame Valve Block Cover

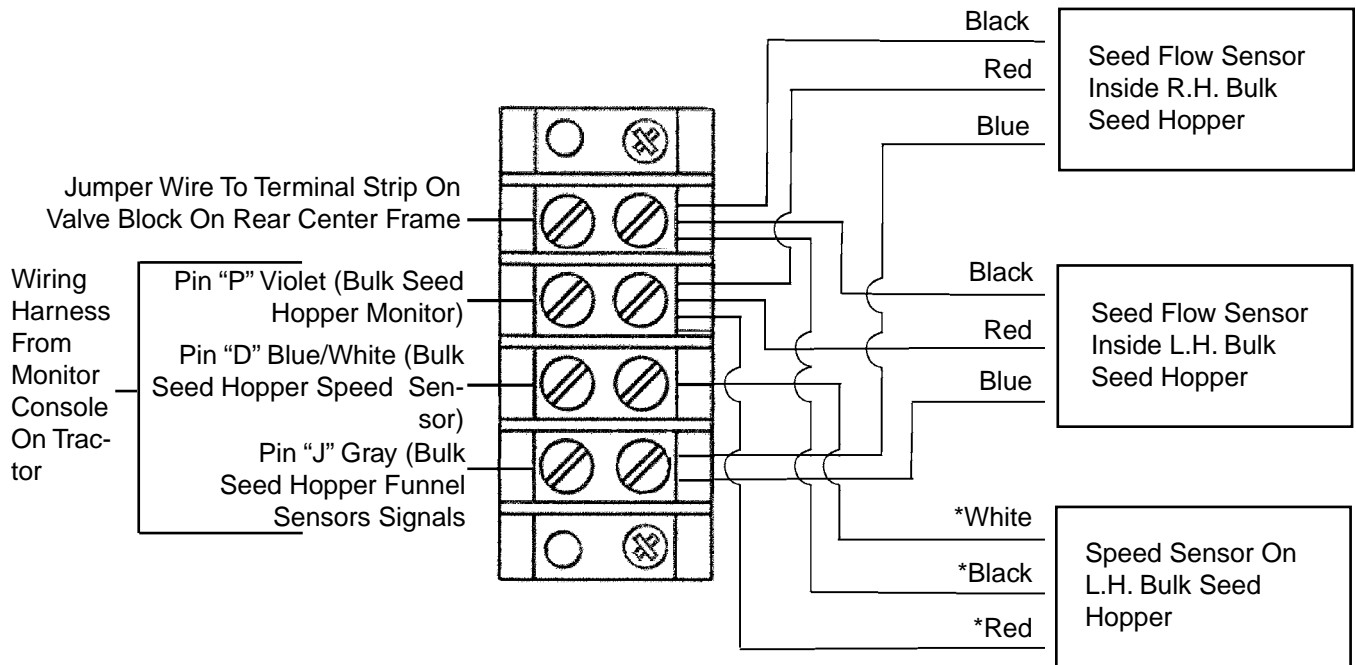

* Speed sensor wire colors are identified by heat shrink tape.

MAINTENANCE

ELECTRICAL CONTROL CONSOLE SCHEMATIC (With Optional Two-Speed Point Row Clutches) (3650 SDS Planter)

(ELC42b/A10189c)

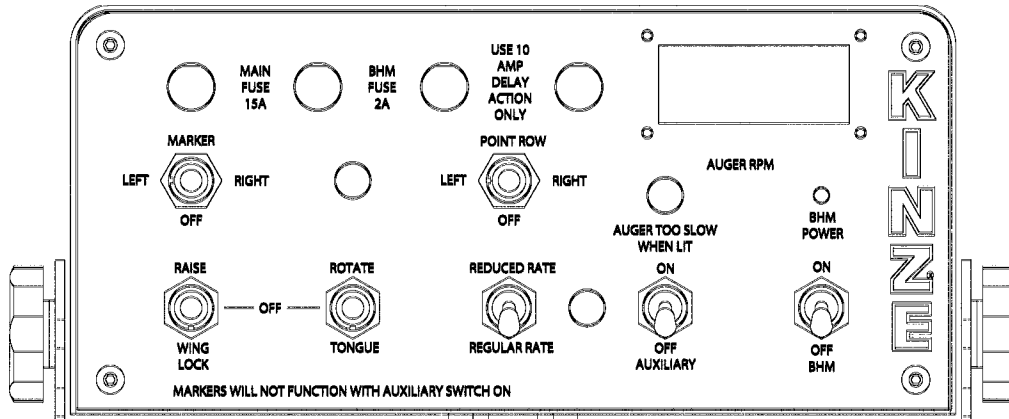
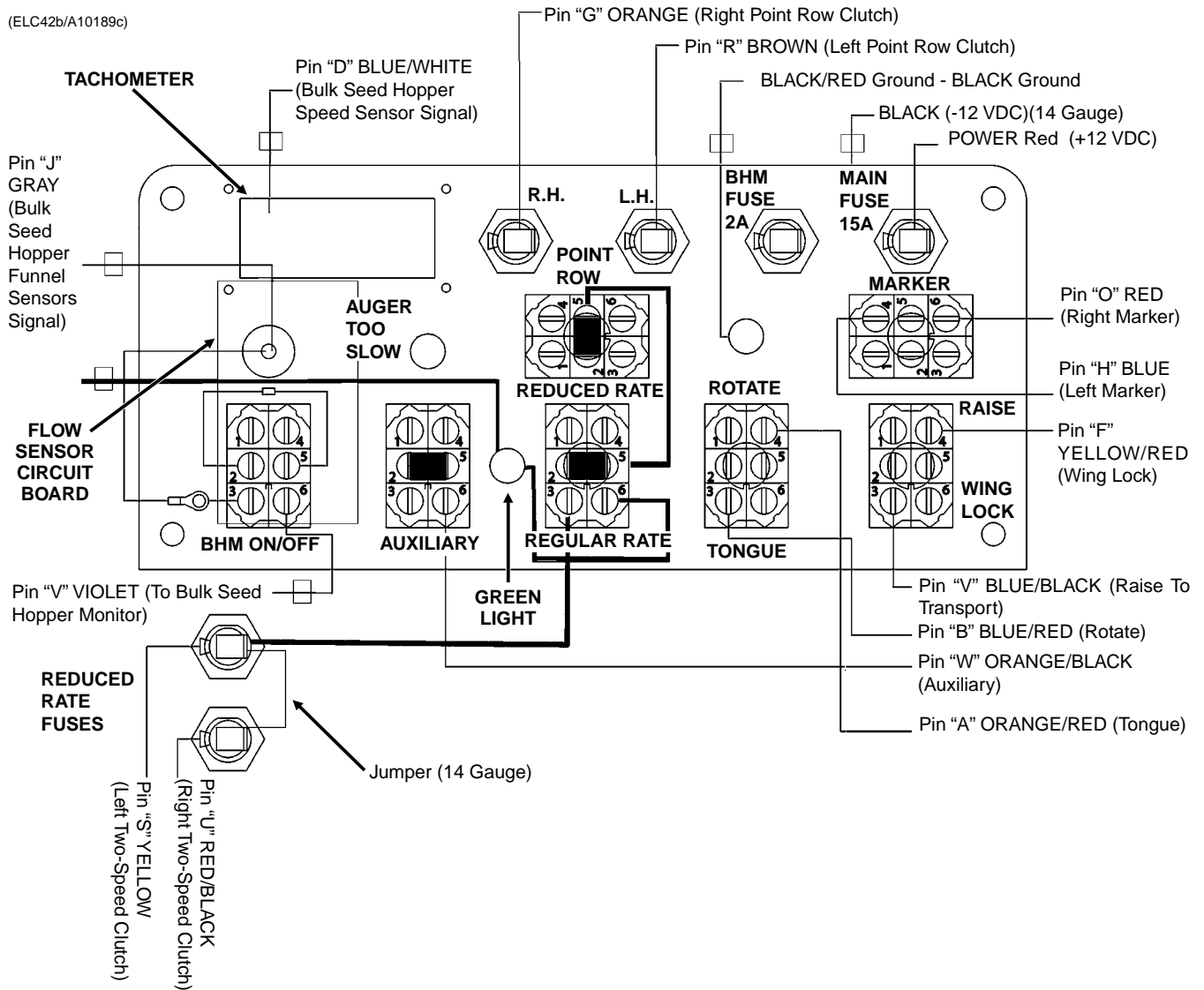

NOTE:

1. Point row and reduced rate clutch switches operate independently of the rest of the control console.
2. Power to the marker switch is fed through the auxiliary switch and the two transport function switches. Operating any of the switches in the lower row disables the marker function and turns off the panel light for the markers.

MAINTENANCE

ELECTRICAL CONTROL CONSOLE SCHEMATIC (With Optional Two-Speed Point Row Clutches) (3650 Conventional)

(PLTR90a/TWL71d/INS70)

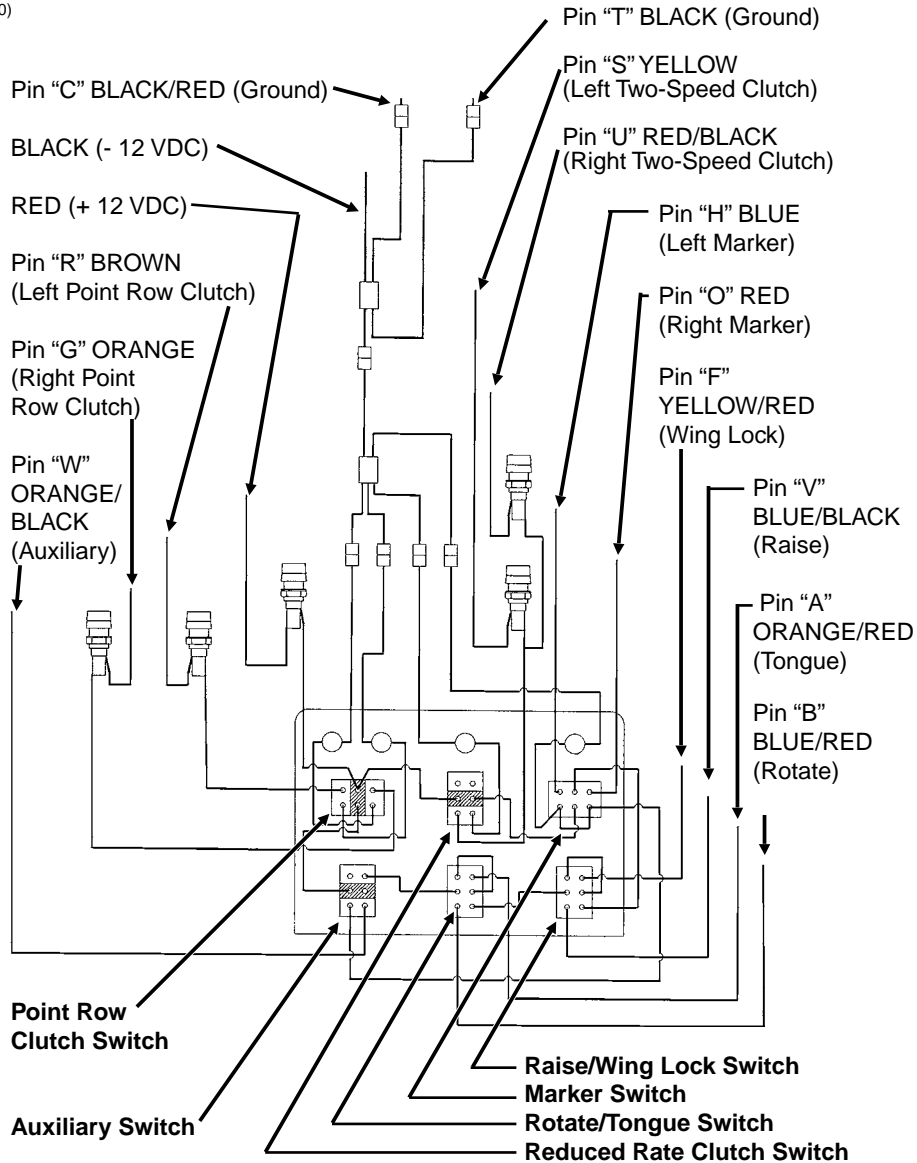

(INS260)

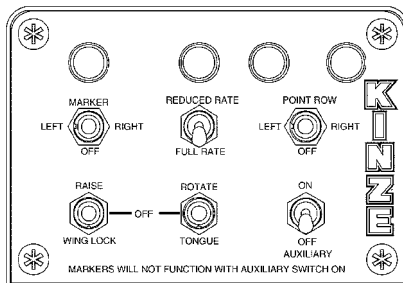

NOTE:

1. Point row and reduced rate clutch switches operate independently of the rest of the control console.
2. Power to the marker switch is fed through the auxiliary switch and the two transport function switches. Operating any of the switches in the lower row disables the marker function and turns off the panel light for the markers.

MAINTENANCE

ELECTRICAL WIRING HARNESS AT TWO-SPEED POINT ROW CLUTCH (3650 SDS And Conventional)

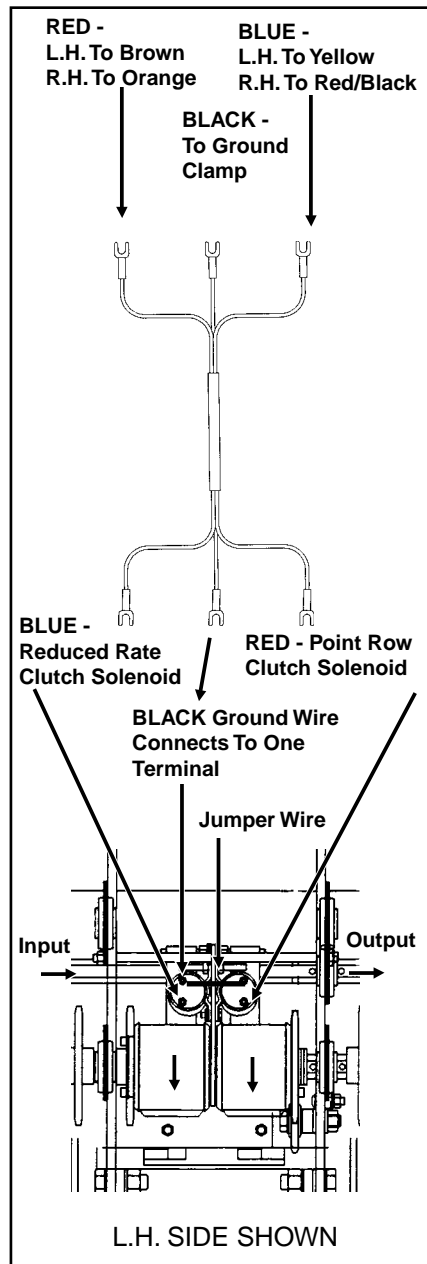

NOTE: Before doing any electrical work, disconnect the control console from the tractor battery. Keep wiring harnesses away from high temperature areas or sharp edges. **DO NOT** route the wiring harnesses along battery cables. Use tie straps to keep wire harness away from moving parts on tractor and planter. Be sure ground connections to the tractor frame are clean to provide good electrical contact.

MAINTENANCE

HYDRAULIC SYSTEM SCHEMATIC (3650 SDS)

(TWL206c/A10125b)

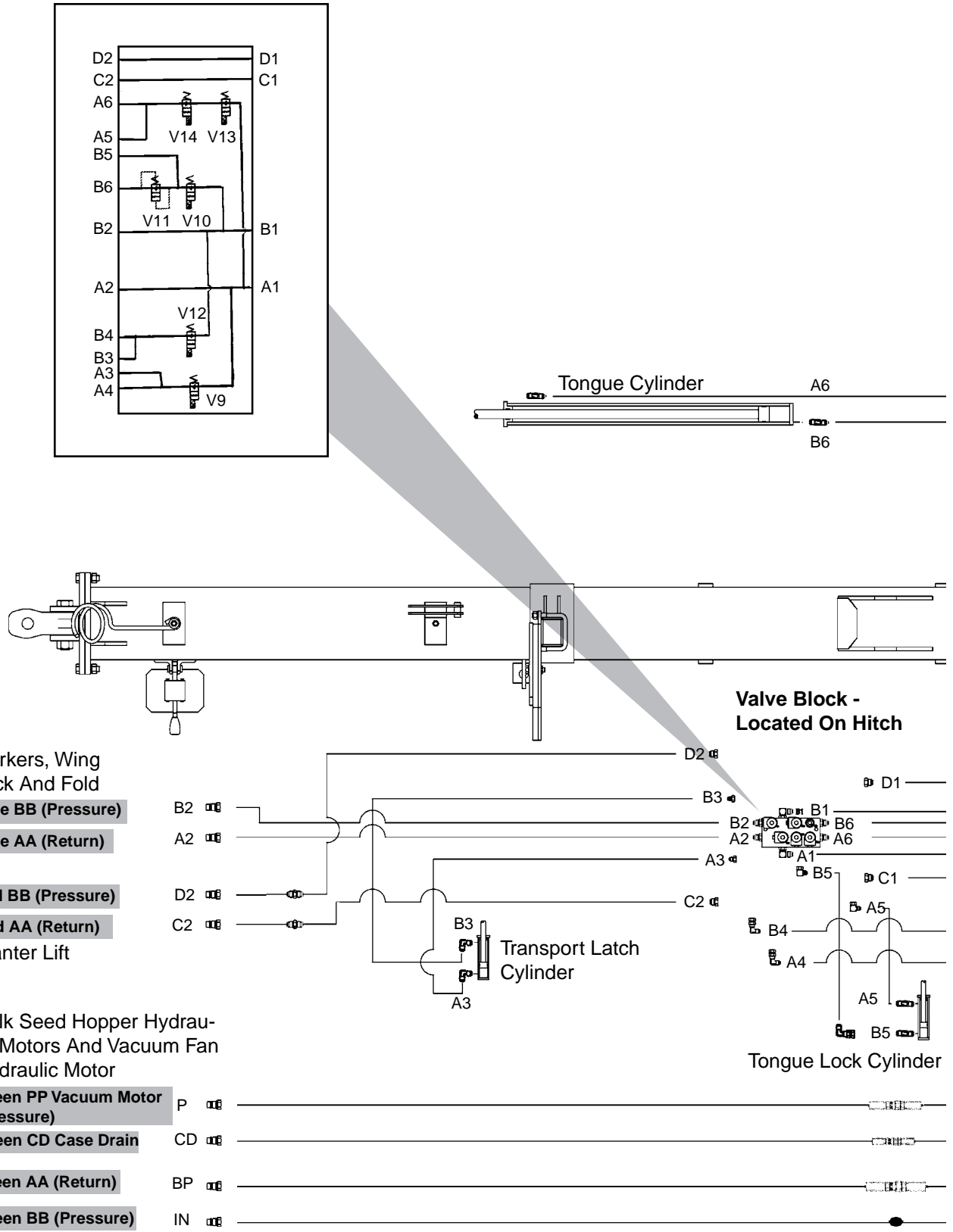

IMPORTANT: Connect hydraulic motor case drain to a case drain return line with zero pressure on the tractor. Failure to connect to a return with zero pressure will cause damage to the hydraulic motor. DO NOT connect hydraulic motor case drain to SCV outlet. Contact tractor manufacturer for specific details on “zero pressure return”.

MAINTENANCE

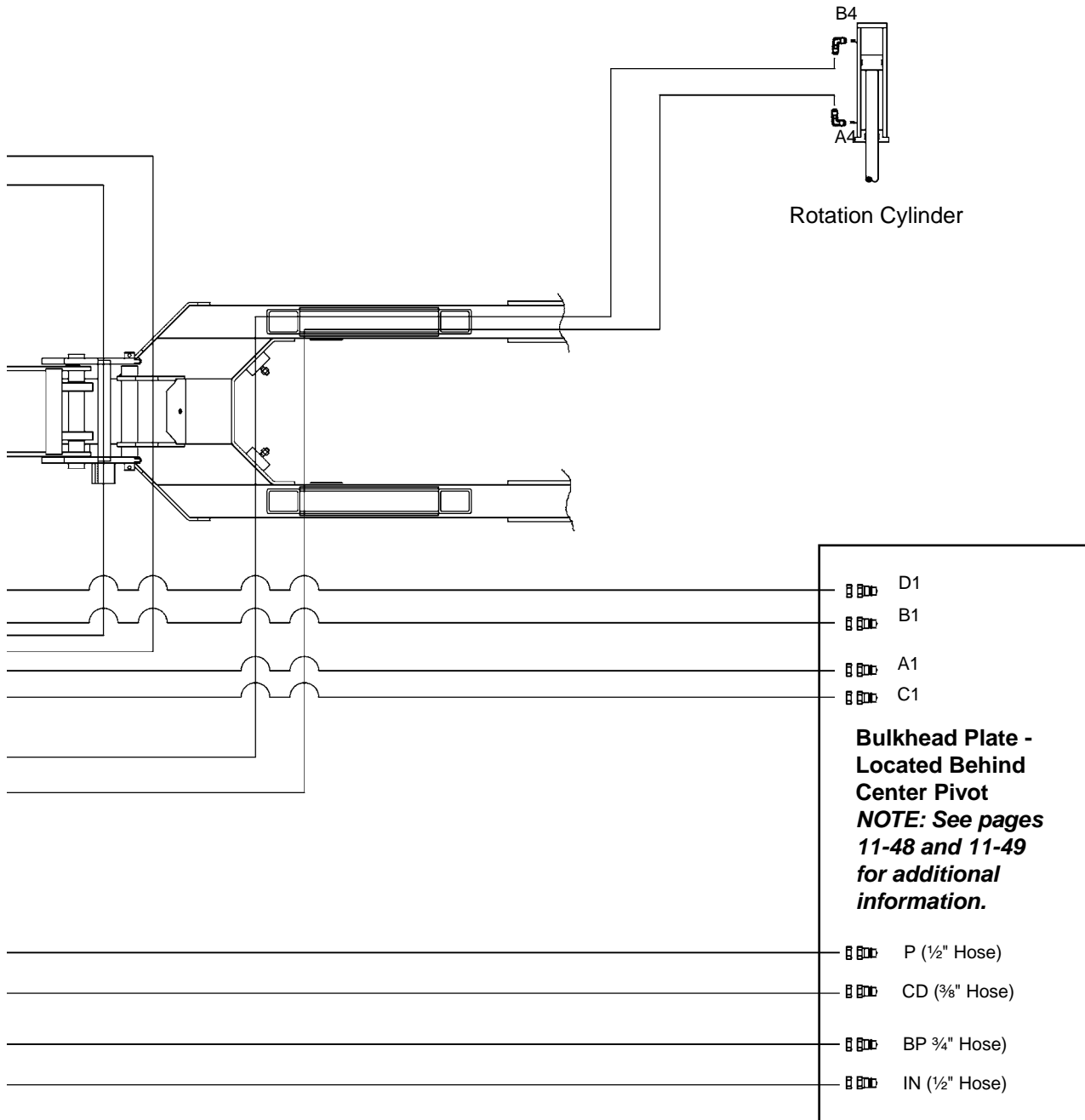
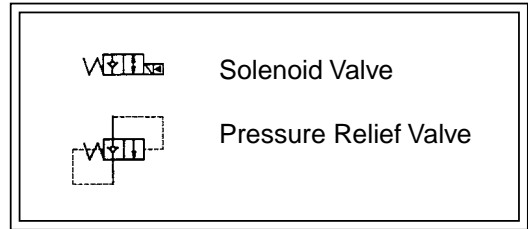

MAINTENANCE

HYDRAULIC SYSTEM SCHEMATIC (3650 Conventional)

(TWL206c/A10125c)

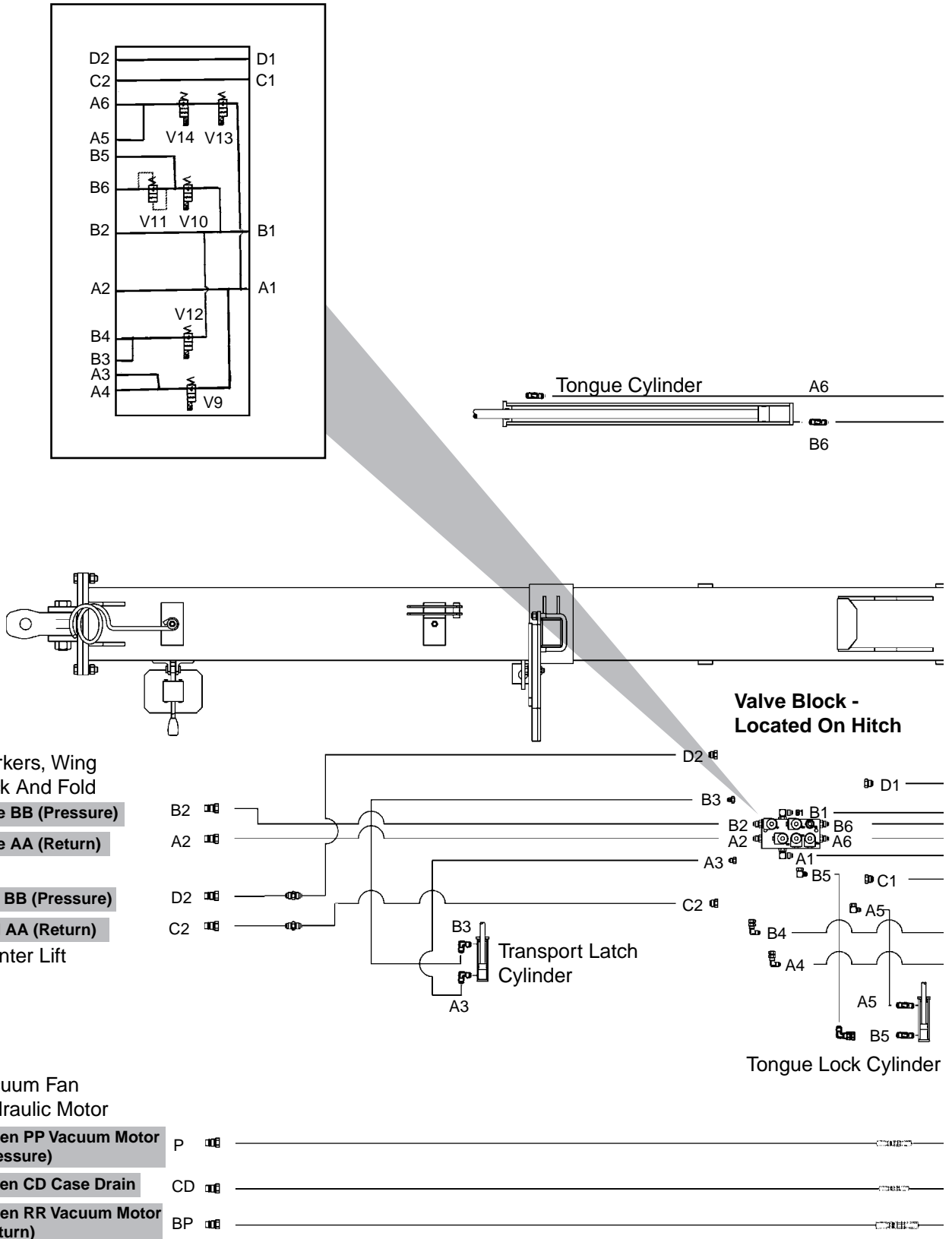

IMPORTANT: Connect hydraulic motor case drain to a case drain return line with zero pressure on the tractor. Failure to connect to a return with zero pressure will cause damage to the hydraulic motor. DO NOT connect hydraulic motor case drain to SCV outlet. Contact tractor manufacturer for specific details on "zero pressure return".

MAINTENANCE

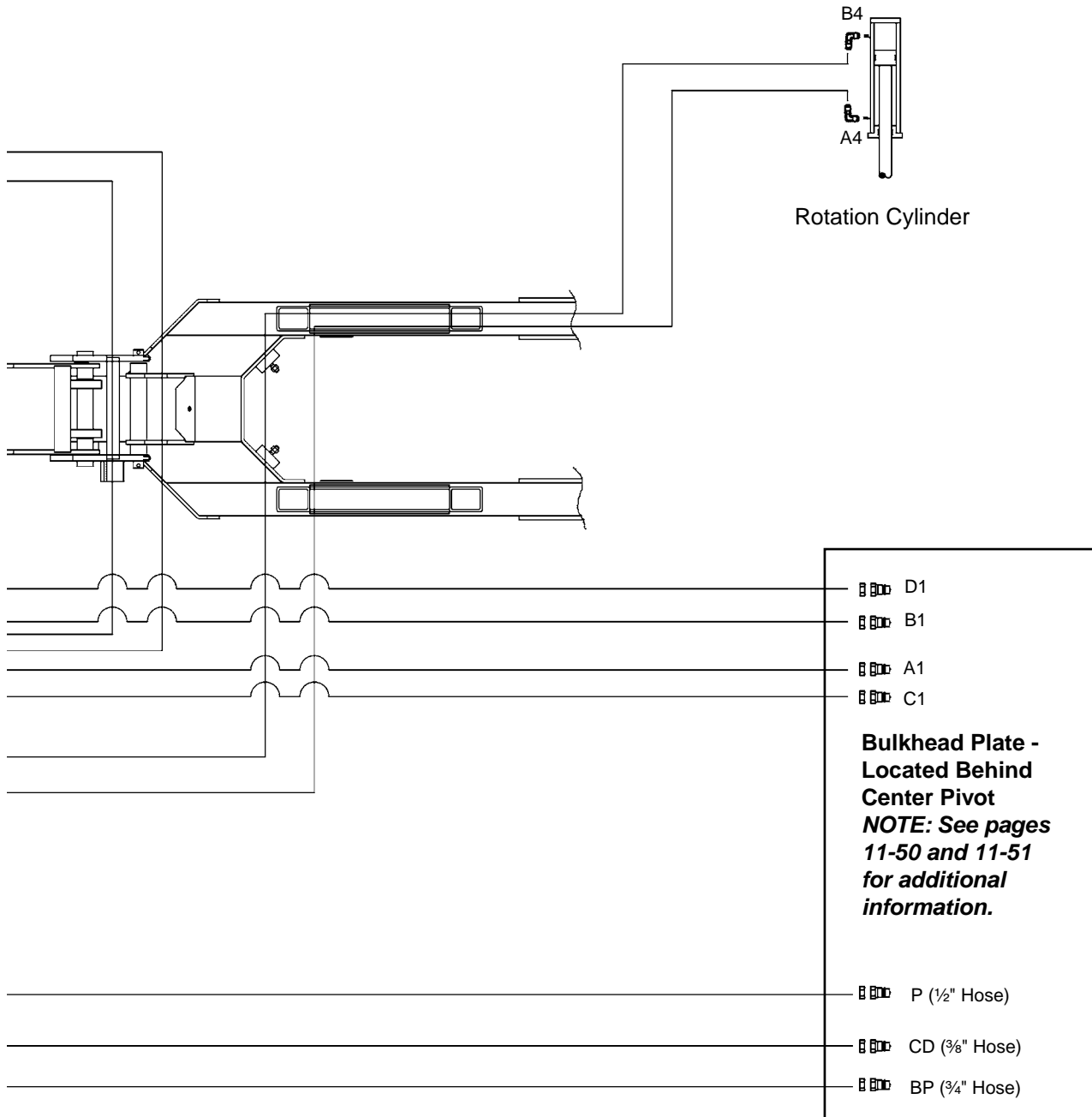
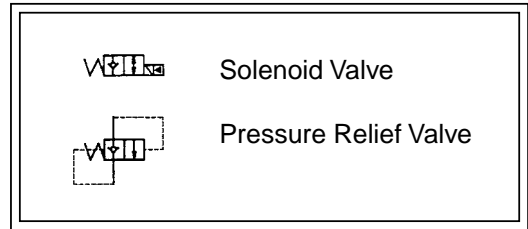

MAINTENANCE

HYDRAULIC SYSTEM SCHEMATIC (3650 SDS)

12 Row 30" (One Wing Lift Cylinder Per Wing)

16 Row 30" Shown (Two Wing Lift Cylinders Per Wing)

(TWL207ee/TWL207eee)

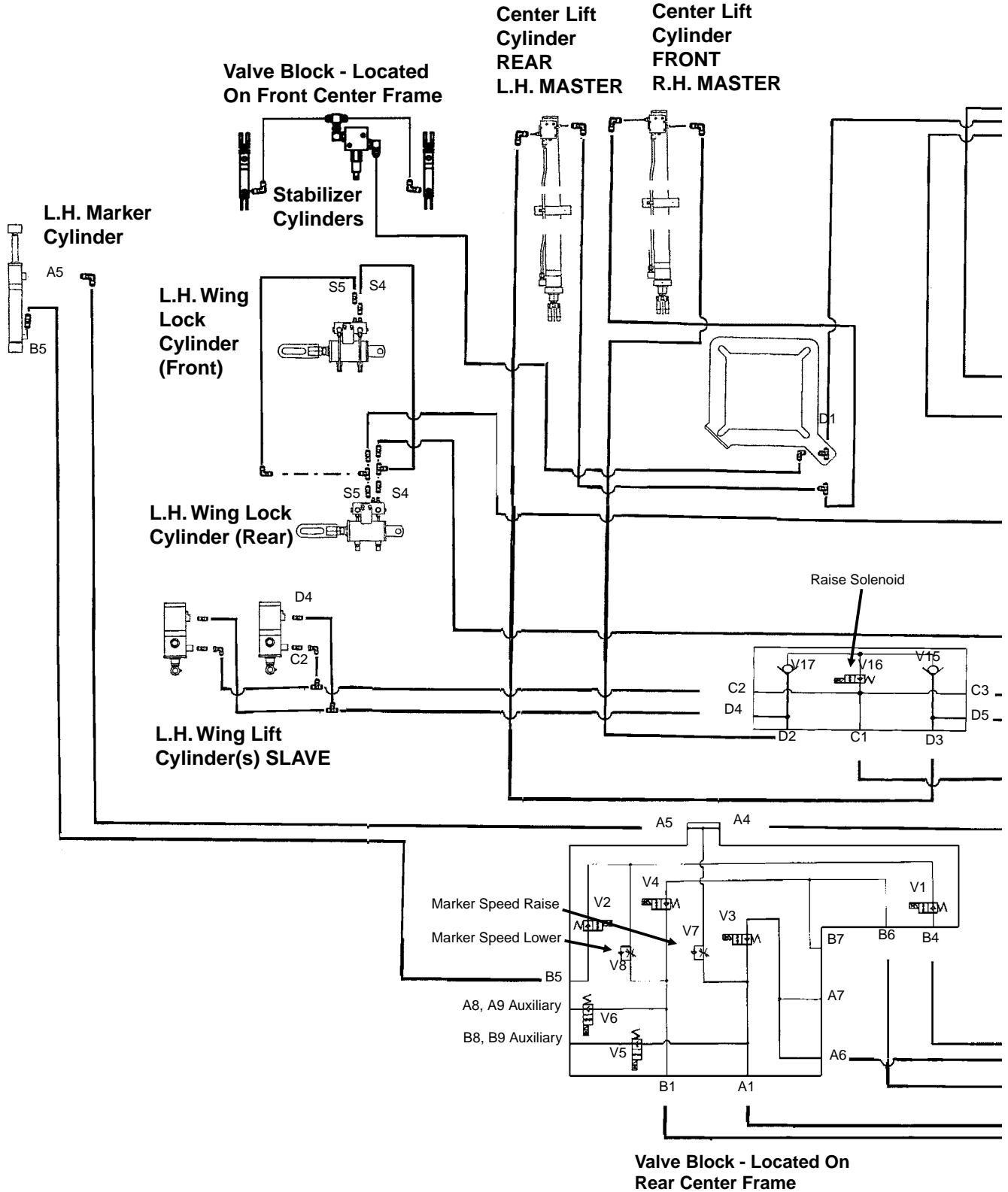

MAINTENANCE

Bulkhead Plate - Located Behind Center Pivot
NOTE: See pages 11-44 and 11-45 for additional information.

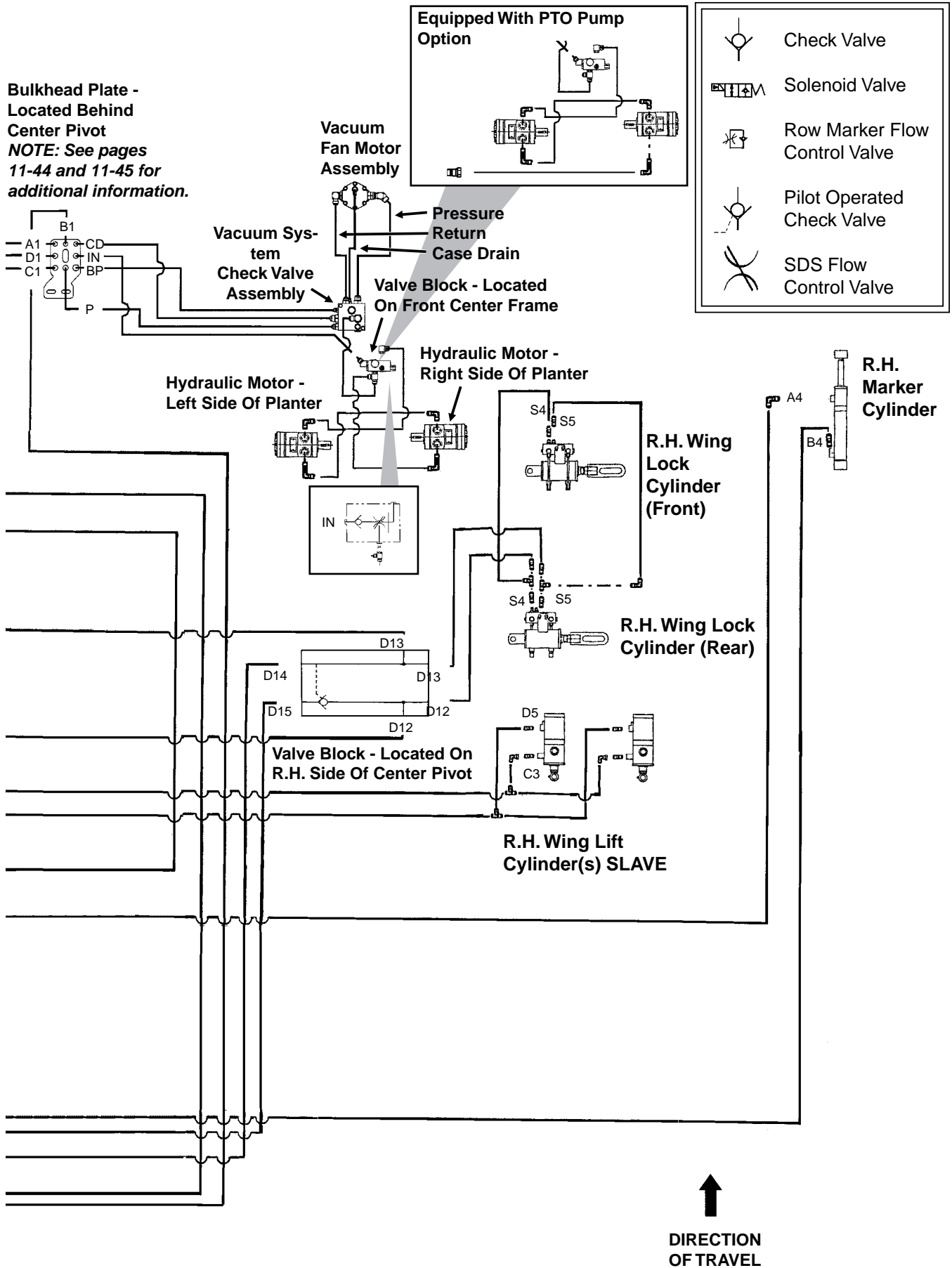

MAINTENANCE

HYDRAULIC SYSTEM SCHEMATIC (3650 Conventional)

12 Row 30" (One Wing Lift Cylinder Per Wing)
 16 Row 30" Shown (Two Wing Lift Cylinders Per Wing)

(TWL207h)

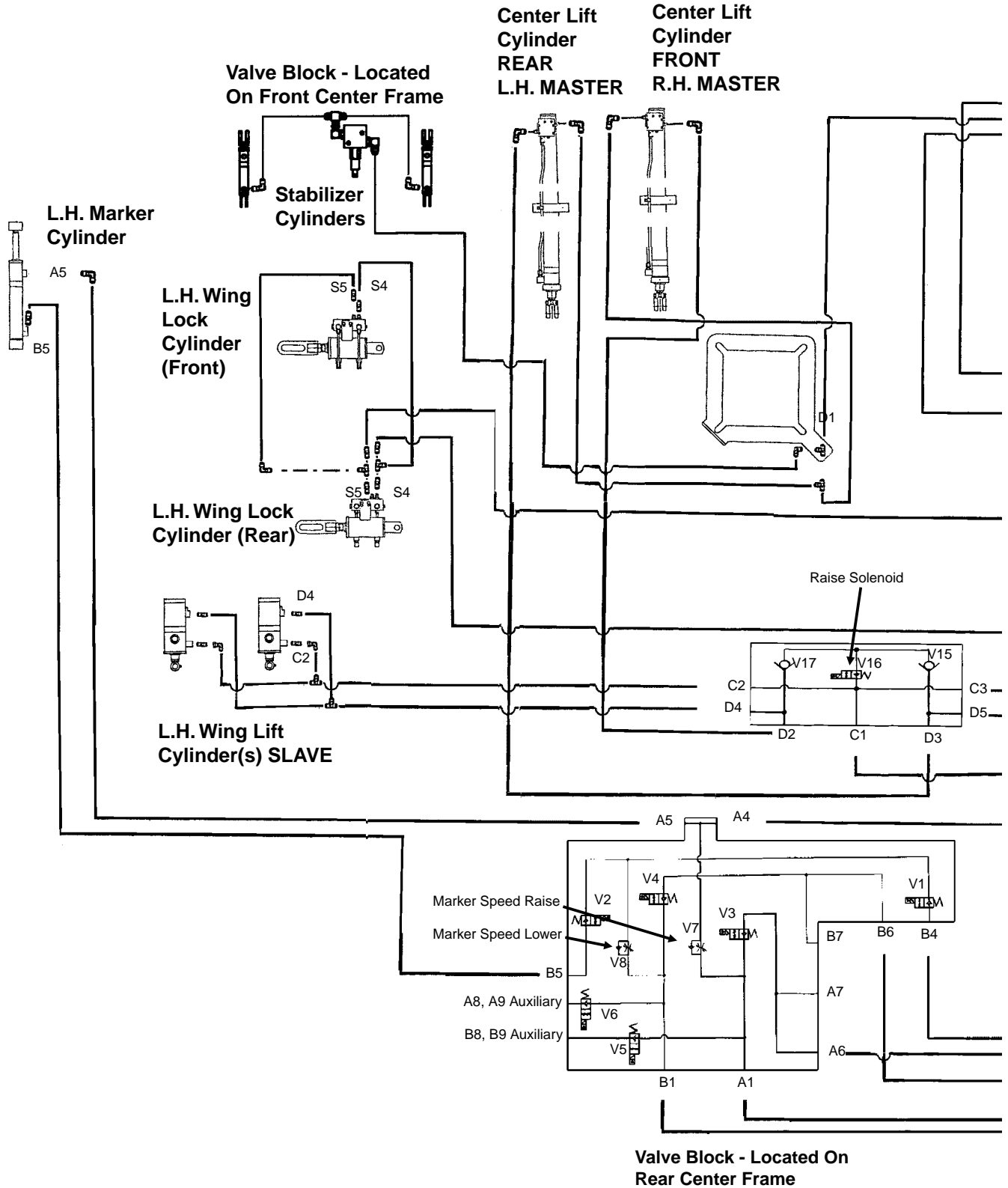

MAINTENANCE

Bulkhead Plate - Located Behind Center Pivot
NOTE: See pages 11-46 and 11-47 for additional information.

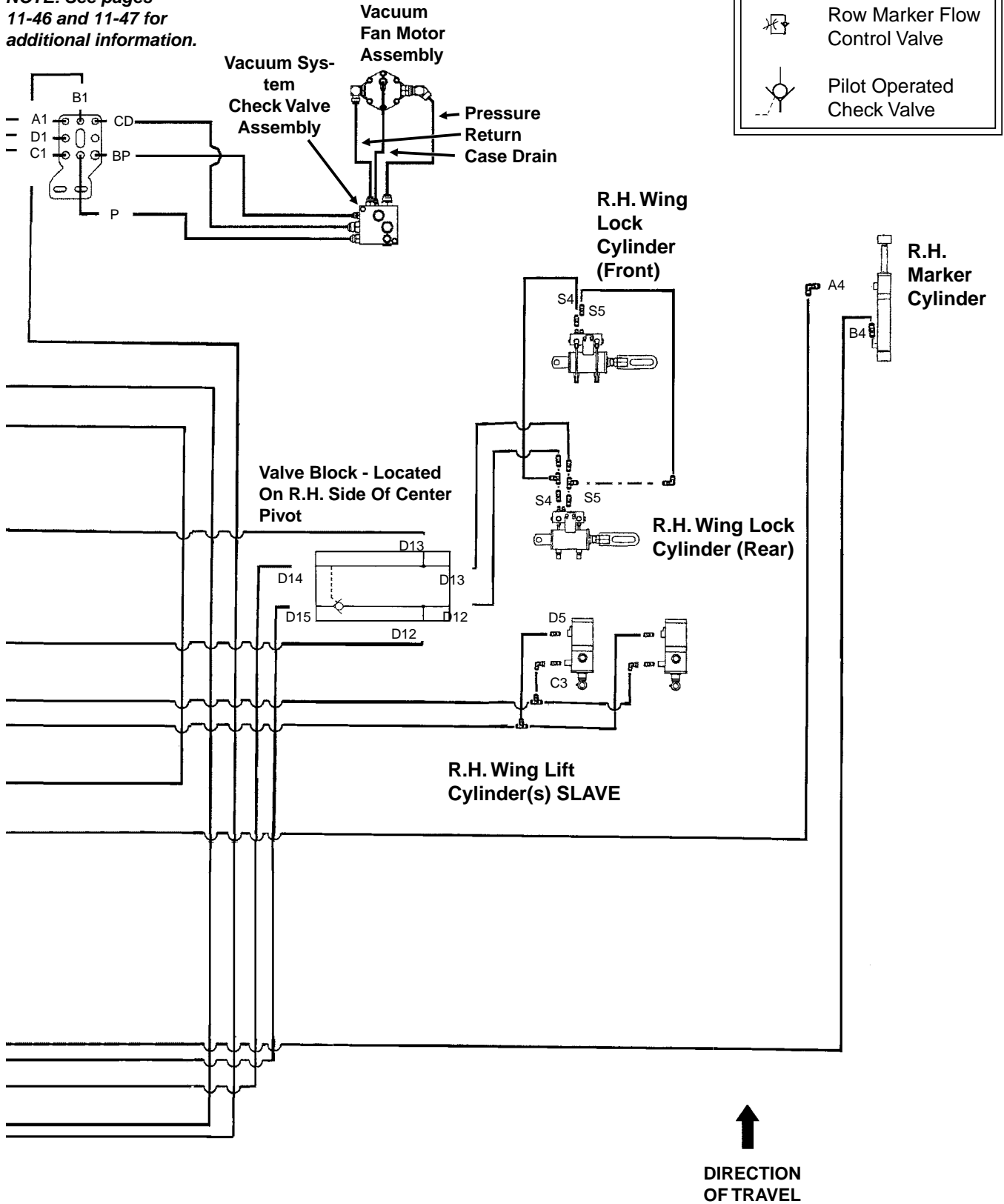

MAINTENANCE

HYDRAULIC SCHEMATIC - VACUUM FAN MOTOR SYSTEM

(TWL305)

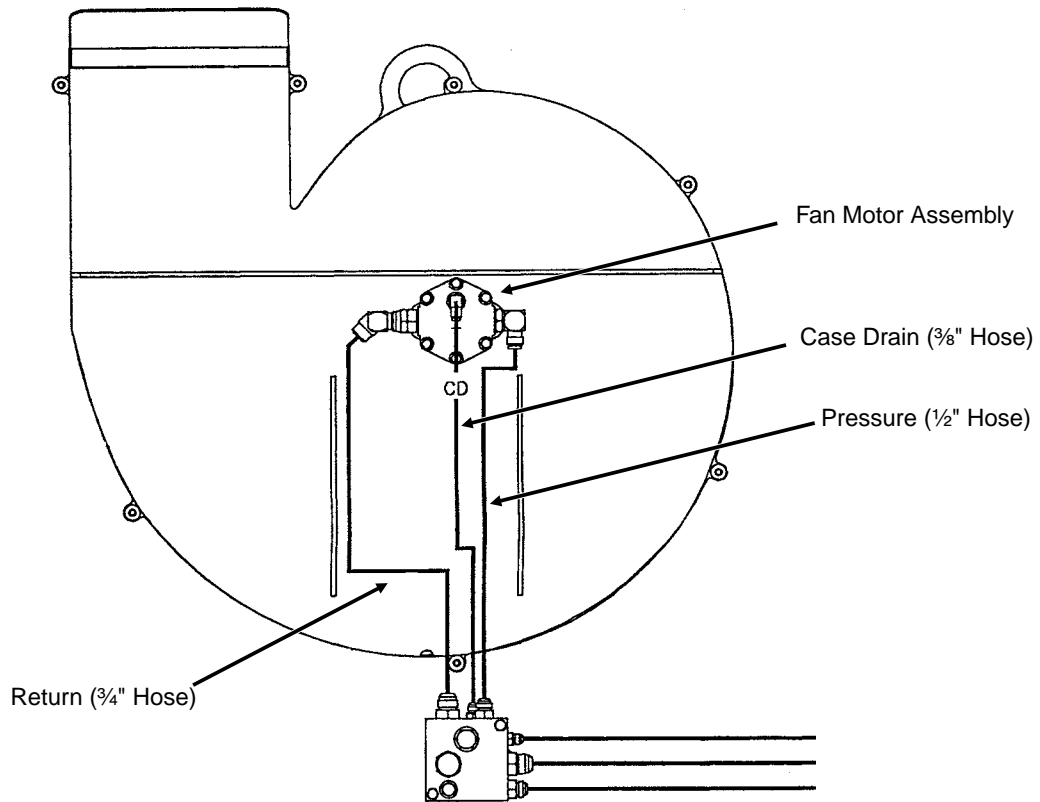

A11068bb

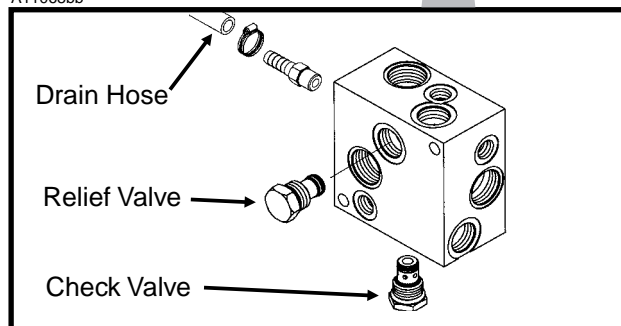

Vacuum Fan Motor Valve
Block Assembly
(See Machine Operation
Section)

IMPORTANT: Connect hydraulic motor case drain to a case drain return line with zero pressure on the tractor. Failure to connect to a return with zero pressure will cause damage to the hydraulic motor. **DO NOT** connect hydraulic motor case drain to SCV outlet. Contact tractor manufacturer for specific details on "zero pressure return".

NOTE: See Hydraulic System Schematics for additional information.

MAINTENANCE

HYDRAULIC SCHEMATIC - OPTIONAL PTO PUMP DRIVE AND OIL COOLER SYSTEM

(TWL290c/TWL306)

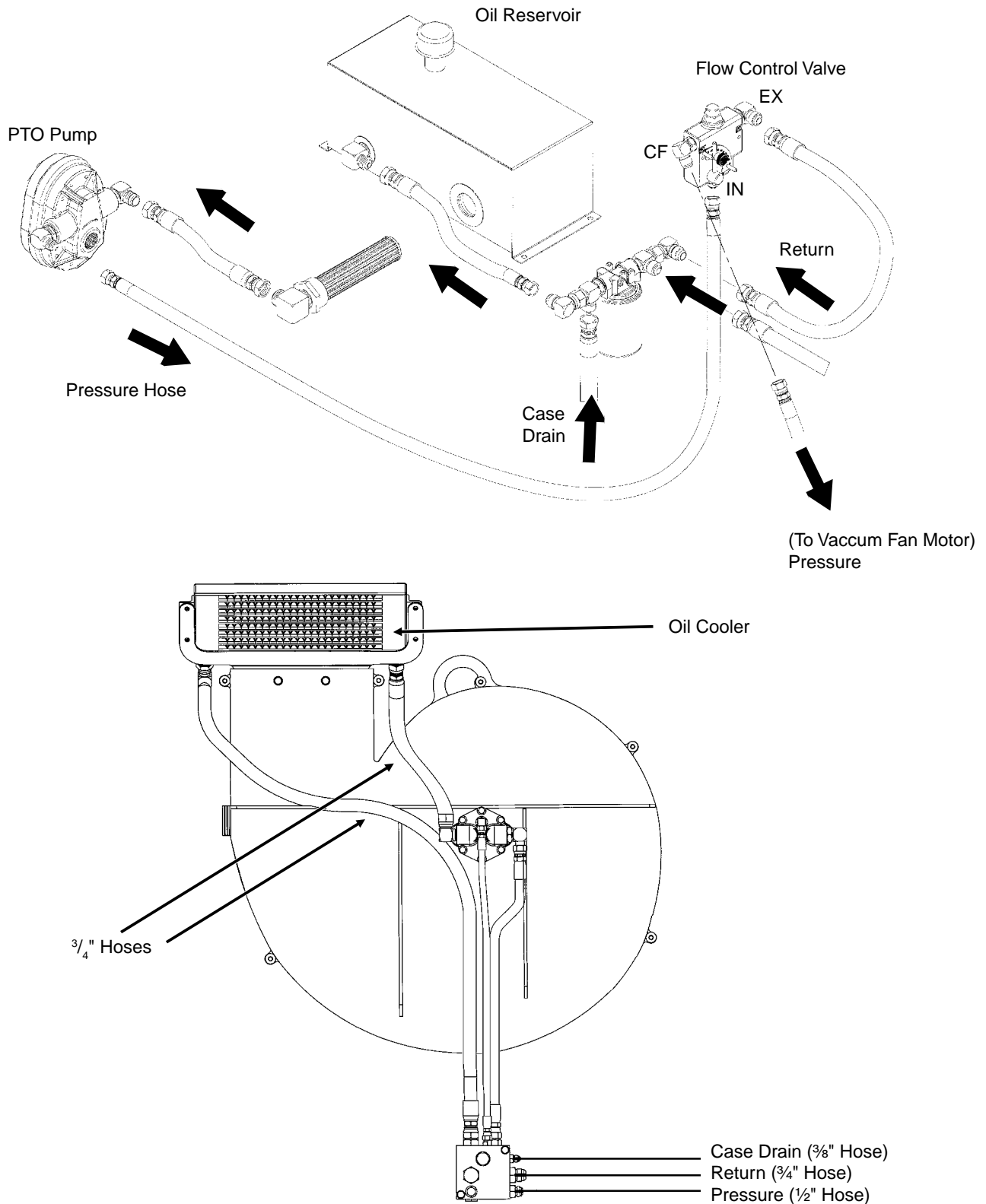

NOTE: See Hydraulic System Schematics for additional information.

MAINTENANCE

PARTS LIST INDEX

ROW UNIT	
15" Seed Opener Disc Blade/Bearing Assembly And Scrapers.....	P5
Coulter Mounted Residue Wheels	P36
Frame Mounted Coulter W/Residue Wheels	P38
Gauge Wheels.....	P6
Granular Chemical Banding Options.....	P29
Granular Chemical Hopper And Hopper Panel Extension.....	P26
Granular Chemical Meter And Meter Drive	P28
Hopper Support And Meter Drive.....	P9
Parallel Arms, Mounting Support Plate And Quick Adjustable Down Force Springs.....	P4
Row Unit Mounted Disc Furrower	P32
Row Unit Mounted No Till Coulter	P30
Row Unit Mounted Residue Wheel	P34
Seed Hopper And Lid (Conventional Planters)	P11
Seed Meter.....	P24
Seed Meter Mount And Drop Hoses (SDS Planters)	P10
Shank Assembly, Seed Tube And Depth Adjustment.....	P2
"V" Closing Wheels.....	P8
EDGEVAC® SYSTEM	
Digital Vacuum Gauge, Analog Vacuum Gauge And Vacuum Fan Assembly	P42
Manifolds And Distribution Hoses	P46
Manifold Assemblies	P48
Optional Flow Control Needle Valve Kit.....	P44
PTO Pump Drive And Oil Cooler Option	P50
Vacuum Fan Hydraulic Motor Assembly.....	P44
Vacuum Fan Motor Valve Block Assembly (Located Below Vacuum Fan Motor Assembly).....	P45
BASE MACHINE	
2-Point Hitch Option	P54
Auxiliary Work Lights Package	P122
Axle Steps	P61
Center Frame	P66
Center Pivot.....	P70
Contact Wheel And Drive Shaft(s)	P72
Cylinders	P91
Electrical Components	P118
Ground Drive Wheel.....	P75
Hose Take-Up.....	P64
Hydraulic Hoses And Fittings	P110
Inner Hitch/Undercarriage Assembly.....	P56
Inner Module Drive.....	P78
Outer Hitch	P52
Point Row Clutch.....	P80
Row Marker Assemblies.....	P86
Row Marker Spindle/Hub/Blade	P90
Safety Chain.....	P52
Seed Rate Transmission And Row Unit Drill Shafts	P76
Stabilizer Assembly.....	P62
Transport Wheels	P60
Two-Speed Point Row Clutch	P82
Two-Speed Point Row Clutch Wheel Module Extension	P84
Valve Blocks.....	P101
Valves (Solenoid, Flow Control, Pressure Relief, Check).....	P107
Wing Frame.....	P68
SDS SEED DELIVERY SYSTEM	
Bulk Seed Hopper And Auger Assemblies.....	P22
Bulk Seed Hopper And Hydraulic Motor Drive	P16
Bulk Seed Hopper Auger Manifold Assembly.....	P20
Bulk Seed Hopper Catwalk	P12
Bulk Seed Hopper Elevator Lift Assembly	P14
Bulk Seed Hopper Lid	P18
Bulk Seed Hopper Monitor Components.....	P128
ELECTRONIC SEED MONITOR	
KPM I Electronic Seed Monitor	P124
KPM II Stack-Mode/KPM III Electronic Seed Monitor	P126
INTERPLANT® SYSTEM	
Interplant® Push Row Unit.....	P40
Interplant® Push Row Unit Drive.....	P130
FERTILIZER	
Openers, Mounts And Attachment	P132
Liquid Fertilizer	P142
Rear Trailer Hitch.....	P158
Decals, Paint And Miscellaneous	P160
Numerical Index	P163

SHANK ASSEMBLY, SEED TUBE AND DEPTH ADJUSTMENT

(D17014/METR29cc/A10142a/D16245)

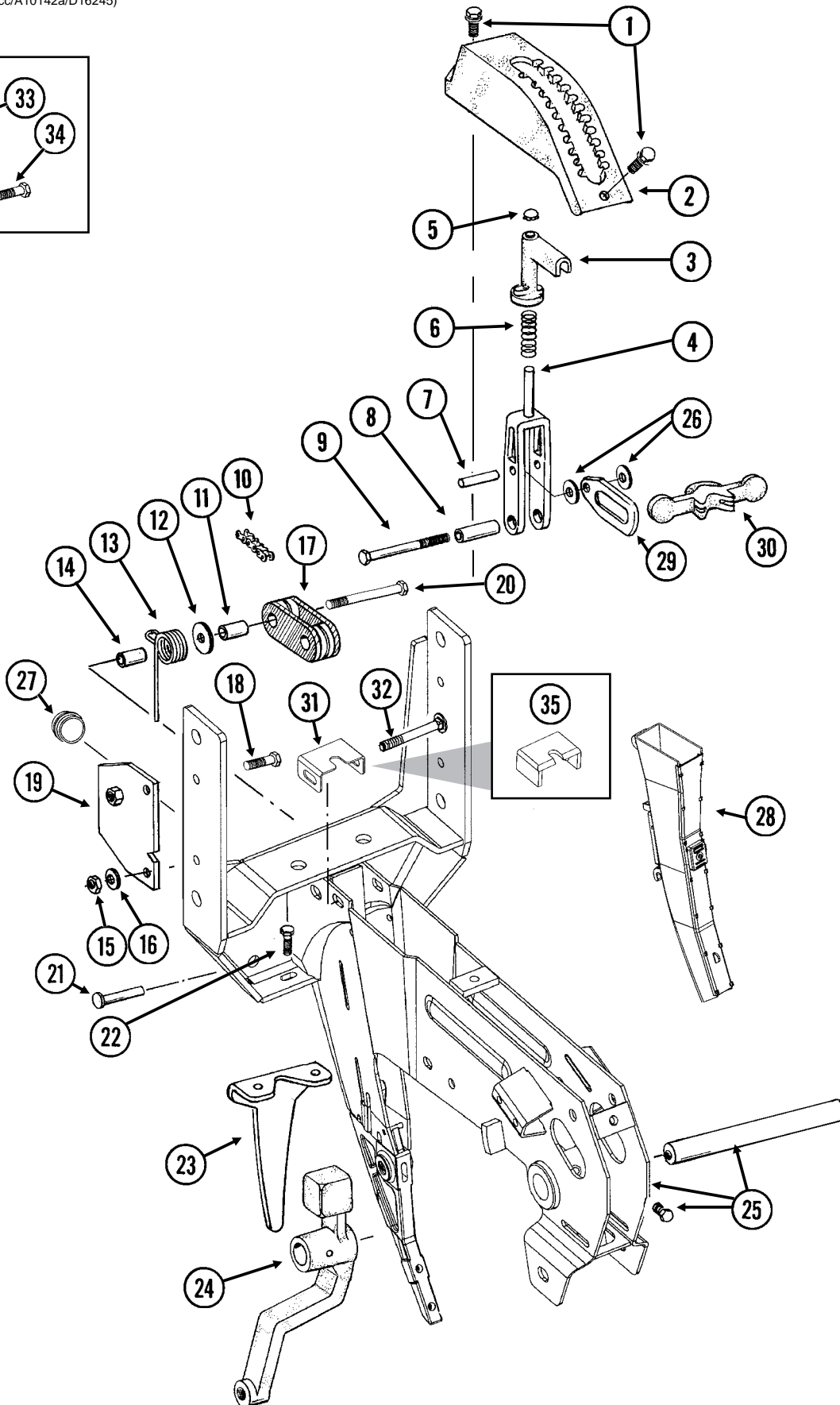
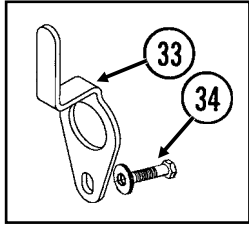

SHANK ASSEMBLY, SEED TUBE AND DEPTH ADJUSTMENT

ITEM	PART NO.	QTY. (Per Row)	DESCRIPTION
1.	G11015	2	Hex Washer Head Cap Screw, 3/8"-16 x 1 1/4"
2.	GB0274	1	Cover, Depth Adjustment
3.	GB0266	1	Handle, Depth Adjustment
4.	GB0267	1	Lever, Depth Adjustment
5.	GD3612	1	Cap Plug
6.	GD10993	1	Spring
7.	GD13361	1	Pin, 3/8" x 1 2/3"
8.	GD11259	1	Sleeve, 3/8" I.D. x 5/8" O.D. x 1 25/32" Long
9.	G11008	1	Hex Head Cap Screw, 3/8"-24 x 2 1/2", Grade 8
	G11007	1	Lock Nut, 3/8"-24, Grade C
10.	G3303-108	1	Chain, No. 41, 108 Pitch Including Connector Link
	G3303-16	1	Chain, No. 41, 16 Pitch Including Connector Link (Used W/Row Unit Extension Brackets)
	GR0196	1	Connector Link, No. 41
11.	GD1026	1	Sleeve, 1 3/16" Long
12.	G10201	1	Special Washer, 3/8" x 1 1/2" O.D.
13.	GD1065	1	Idler Spring
14.	GD7318	1	Sleeve, 1" Long
15.	G10108	1	Lock Nut, 3/8"-16
16.	G10210	1	Washer, 3/8" USS
17.	GD11962	1	Idler
18.	G10003	3	Hex Head Cap Screw, 3/8"-16 x 1 1/2"
	G10108	3	Lock Nut, 3/8"-16
19.	GD10867	2	Stop
20.	G10326	1	Hex Head Cap Screw, 3/8"-16 x 3 3/4"
21.	G10551	1	Clevis Pin, 1/4" x 2 1/2"
	G10669	1	Hair Pin Clip, No. 22
22.	G10312	2	Carriage Bolt, 5/16"-18 x 3/4"
	G10620	2	Serrated Flange Nut, 5/16"-18
23.	GD1033	1	Shield
24.		-	See "Gauge Wheels", Pages P6 And P7
25.	GA10157	1	Shank W/Gauge Wheel Pivot Spindle And Set Screw
	GD11001	-	Spindle
	G10438	-	Hex Head Cap Screw, 1/2"-13 x 3/4"
26.	G10207	2	Washer, 7/8" O.D. x 1 3/32" I.D. x .134" (If Applicable)
27.	GD11845	1	Dust Cap
28.			See "KPM I Electronic Seed Monitor" And "KPM II Stack-Mode/KPM III Electronic Seed Monitors", Pages P124-P127
29.	GB0285	1	Collar, Depth Adjustment
30.	GB0265	1	Pivot Link, Depth Adjustment
31.	GD15970	1	Sun Shade
32.	G10304	1	Carriage Bolt, 3/8"-16 x 3"
	G10108	1	Lock Nut, 3/8"-16
33.	GD17014	1	Hose Guide
34.	G10047	1	Hex Head Cap Screw, 3/8"-16 x 1 3/4"
	G10203	2-3	Washer, 3/8" SAE
	G10108	1	Lock Nut, 3/8"-16
35.	GD16245	-	Sun Shade (Rubber)

PARALLEL ARMS, MOUNTING SUPPORT PLATE AND QUICK ADJUSTABLE DOWN FORCE SPRINGS

RUB021/RUB022(RU78f/RU79a)

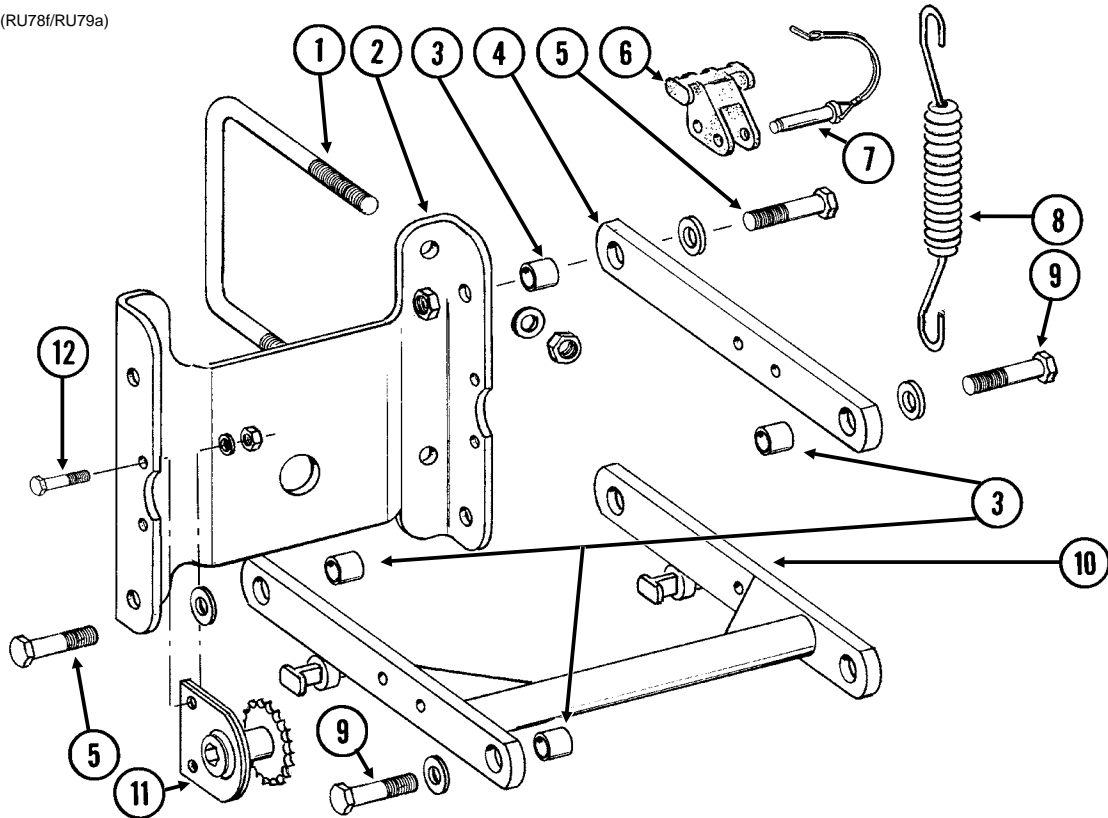

ITEM	PART NO.	QTY. (Per Row)	DESCRIPTION
1.	GD1113	2	U-Bolt, 5" x 7" x 5/8"-11
	G10230	4	Lock Washer, 5/8"
	G10104	4	Hex Nut, 5/8"-11
2.	GD10036	1	Mounting Support Plate
3.	GB0218	4	Bushing, 2 1/32" I.D. x 7/8" O.D. x 1 9/32" Long
4.	GD11422	2	Upper Parallel Arm
5.	G10732	4	Hex Head Cap Screw, 5/8"-18 x 2"
	GD7805	4	Special Washer, 5/8", Hardened
	G10412	4	Lock Nut, 5/8"-18
6.	GB0186	2	Spring Anchor
7.	GD14217	2	Tab Lock Pin, 7/16" x 1 1/2"
8.	GD8249	2-4	Spring
9.	-	-	See "Hopper Support And Meter Drive", Page P9
10.	GA5651	1	Lower Parallel Arm
11.	GA1720	1	Bearing/Sprocket, 7/8" Hex Bore
12.	G10001	2	Hex Head Cap Screw, 3/8"-16 x 1"
	G10229	2	Lock Washer, 3/8"
	G10101	2	Hex Nut, 3/8"-16
A.	G6325X	-	U-Bolt Package For 5" x 7" Toolbar, Includes: (2) GD1113, (4) G10230, (4) G10104

15" SEED OPENER DISC BLADE/BEARING ASSEMBLY AND SCRAPERS

(RU139)

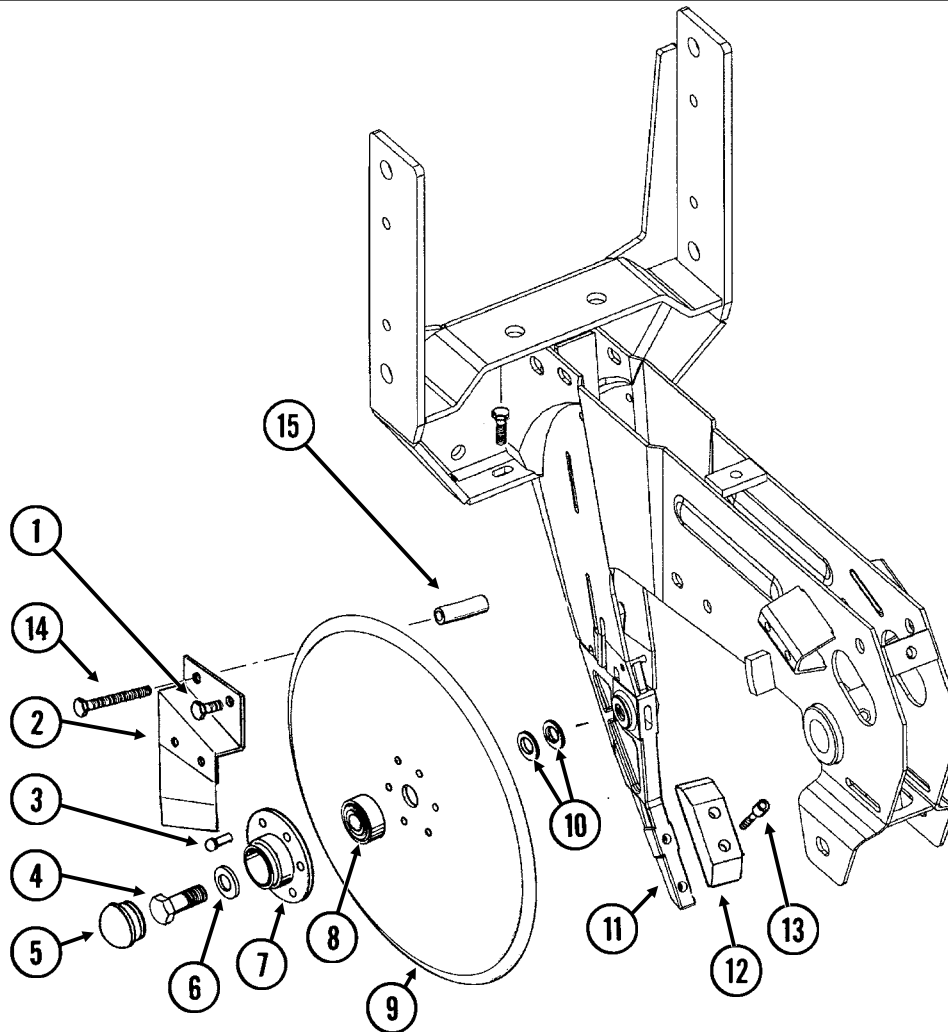

ITEM	PART NO.	QTY. (Per Row)	DESCRIPTION
1.	G10328	2	Hex Head Cap Screw, 3/8"-16 x 5/8"
	G10622	2	Serrated Flange Nut, 3/8"-16
2.	GA2012R	1	Disc Scraper, R.H.
	GA2012L	-	Disc Scraper, L.H. (Shown)
3.	G10427	12	Rivet, 1/4" x 1/2"
4.	GD11017	1	Special Hex Head Cap Screw, 5/8"-11 x 1 1/2", L.H. Threads
	G10007	1	Hex Head Cap Screw, 5/8"-11 x 1 1/2"
5.	GD11845	2	Dust Cap
6.	G10204	2	Special Machine Bushing, 5/8" x 1" O.D.
7.	GD10473	2	Bearing Housing
8.	GA2014	2	Bearing
9.	GD11306	2	Disc Blade, 3.5 mm x 15"
10.	G10213	-	Machine Bushing, 5/8" (.030" Thick)(As Required)
11.		-	See "Shank Assembly", Pages P2 And P3
12.	GB0301	1	Seed Tube Guard/Inner Scraper
13.	G10912	2	Hex Socket Head Cap Screw, 5/16"-18 x 1", Grade 8
14.	G10325	1	Hex Head Cap Screw, 3/8"-16 x 2 3/4"
	G10622	1	Serrated Flange Nut, 3/8"-16
15.	GD11259	1	Sleeve, 3/8" I.D. x 5/8" O.D. x 1 25/32" Long
A.	GA8324	-	Disc Blade/Bearing Assembly, Less Dust Cap (Items 3 And 7-9)

GAUGE WHEELS

(RU140)

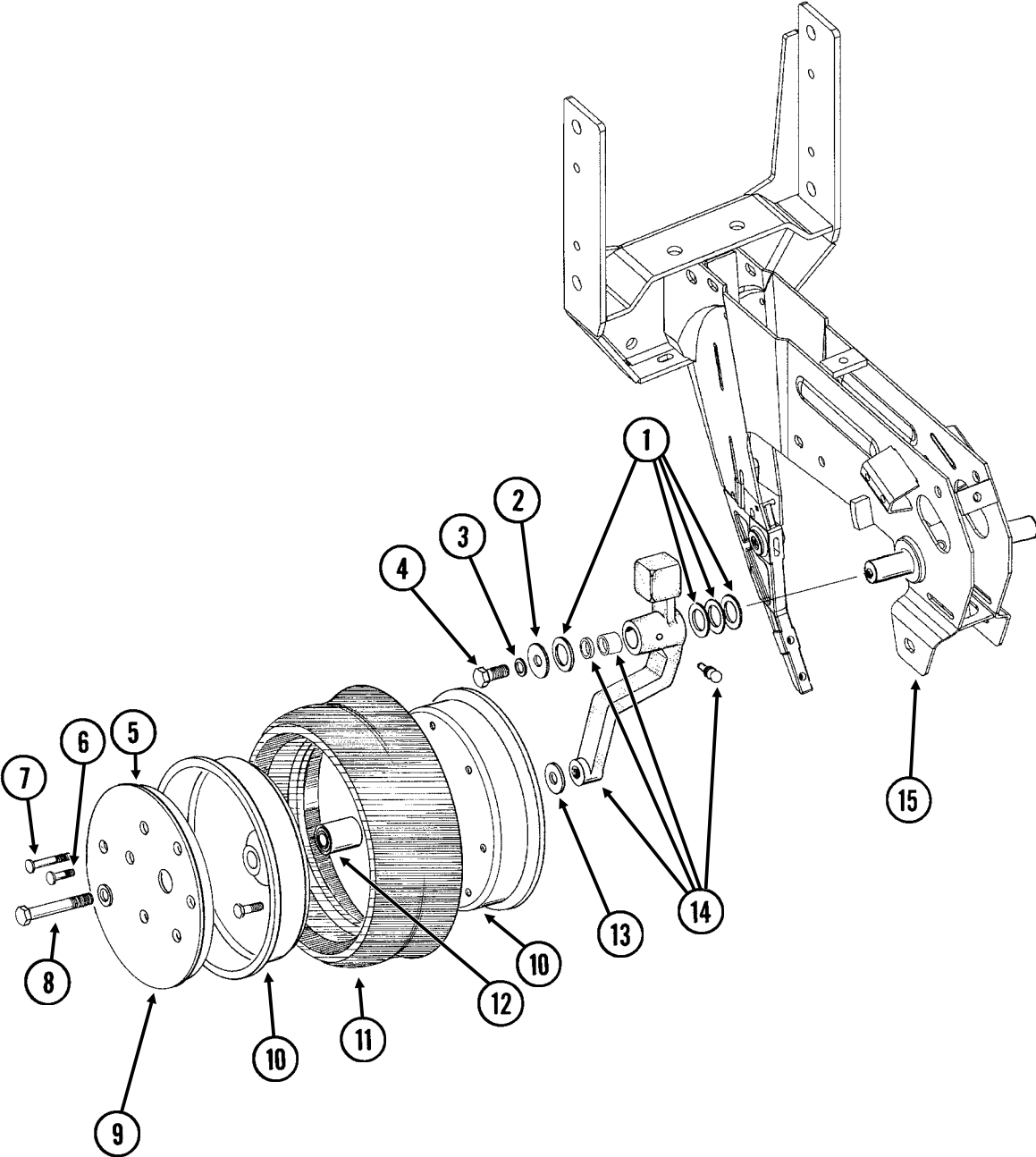

GAUGE WHEELS

ITEM	PART NO.	QTY. (Per Row)	DESCRIPTION
1.	G10940	-	Machine Bushing, 1" (.048" Thick)
2.	G10216	2	Washer, 1/2" USS
3.	G10228	2	Lock Washer, 1/2"
4.	G10014	1	Hex Head Cap Screw, 1/2"-13 x 1"
5.	GD11453	2	Cover
6.	G10338	12	Carriage Bolt, 5/16"-18 x 1 1/4"
	G10620	12	Serrated Flange Nut, 5/16"-18
7.	G10924	8	Carriage Bolt, 5/16"-18 x 1 3/4"
	G10620	8	Serrated Flange Nut, 5/16"-18
8.	G10010	2	Hex Head Cap Screw, 5/8"-11 x 3"
	G10230	2	Lock Washer, 5/8"
9.	G10018	14	Hex Head Cap Screw, 5/16"-18 x 5/8"
	G10109	14	Lock Nut, 5/16"-18, Grade 8
10.	GD11423	4	Half Wheel
11.	GD1086	2	Tire
12.	GA6171	2	Bearing
13.	G10204	2	Special Machine Bushing, 5/8" x 1" O.D.
14.	GA7975	1	Wheel Arm W/Grease Fitting, Bushings And Seals, L.H. (Shown)
	GA7976	1	Wheel Arm W/Grease Fitting, Bushings And Seals, R.H.
	G10640	1	Grease Fitting, 1/4"-28 (Per Arm)
	GB0276	2	Bushing, 1" I.D. x 1 1/4" O.D. x 1" Long (Per Arm)
	GD10991	2	Seal (Per Arm)
15.		-	See "Shank Assembly", Pages P2 And P3
A.	GA7949	-	Gauge Wheel Complete (Items 5-7 And 9-12)
B.	G1K296	-	Gauge Wheel Arm Bushing And Seal Driver Kit, Includes: (1) Seal Driver, (1) Bushing Driver, (1) Instruction

"V" CLOSING WHEELS

(RU83i/RU83n)

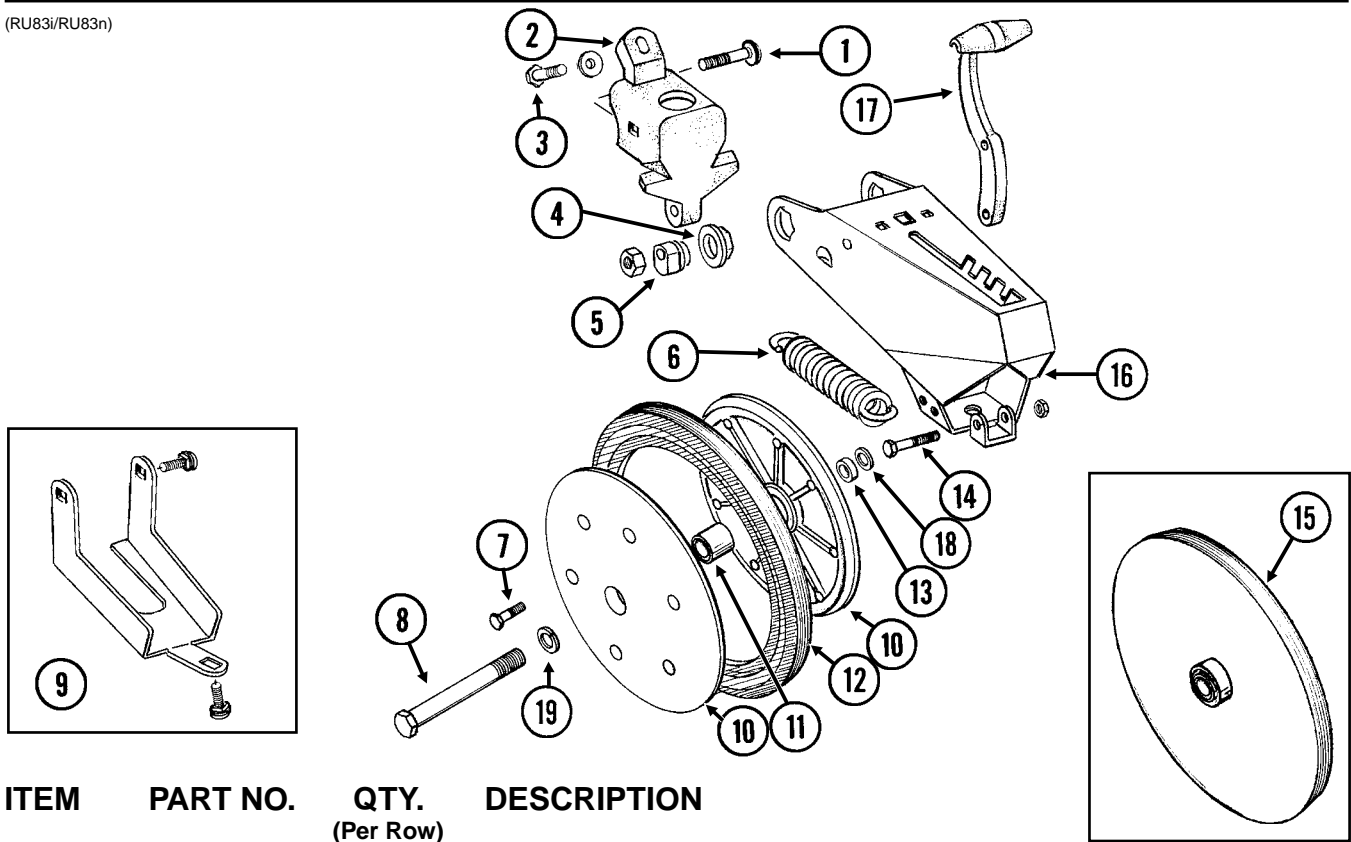

ITEM	PART NO.	QTY. (Per Row)	DESCRIPTION
1.	G10801	2	Carriage Bolt, 1/2"-13 x 2 1/4"
	G10315	-	Carriage Bolt, 1/2"-13 x 2 1/2" (Used W/Straight Drop In-Furrow Granular Chemical Bracket)
	G10111	2	Lock Nut, 1/2"-13
2.	GB0268	1	Wheel Arm Stop
3.	G10001	1	Hex Head Cap Screw, 3/8"-16 x 1"
	G10210	1	Washer, 3/8" USS
4.	GB0282	2	Stepped Bushing
5.	GB0239	2	Eccentric Bushing
6.	GD8460	1	Spring
7.	G10064	6	Hex Head Cap Screw, 1/4"-20 x 1"
8.	G10013	2	Hex Head Cap Screw, 5/8"-11 x 3 1/2"
	G10107	2	Lock Nut, 5/8"-11
9.	G1K345	-	Closing Wheel Shield Kit W/Hardware And Instruction
	G10308	2	Carriage Bolt, 3/8"-16 x 3/4"
	G10599	1	Carriage Bolt, 3/8"-16 x 1 1/4"
	G10210	1	Washer, 3/8" USS
	G10229	3	Lock Washer, 3/8"
	G10101	3	Hex Nut, 3/8"-16
10.	GD9120	4	Nylon Half Wheel
11.	GA6171	2	Bearing
12.	GD1085	2	Rubber Tire, 1" x 12"
13.	GD1109	2	Bushing, 4 1/64" I.D. x 7/8" O.D. x 1/4" Long
14.	G10133	1	Hex Head Cap Screw, 5/16"-18 x 1 1/2"
	G10109	1	Lock Nut, 5/16"-18, Grade 8
15.	GA6597	-	Cast Iron Closing Wheel W/Bearing
	GA6171	-	Bearing
16.	GA8322	1	Arm
17.	GB0254	1	Lever
18.	GD7805	2	Special Washer, 5/8", Hardened
19.	G10230	2	Lock Washer, 5/8"
A.	GA6434	-	Rubber Closing Wheel Complete W/Bearing (Items 7 And 10-12)

HOPPER SUPPORT AND METER DRIVE

(METR72/METRff)

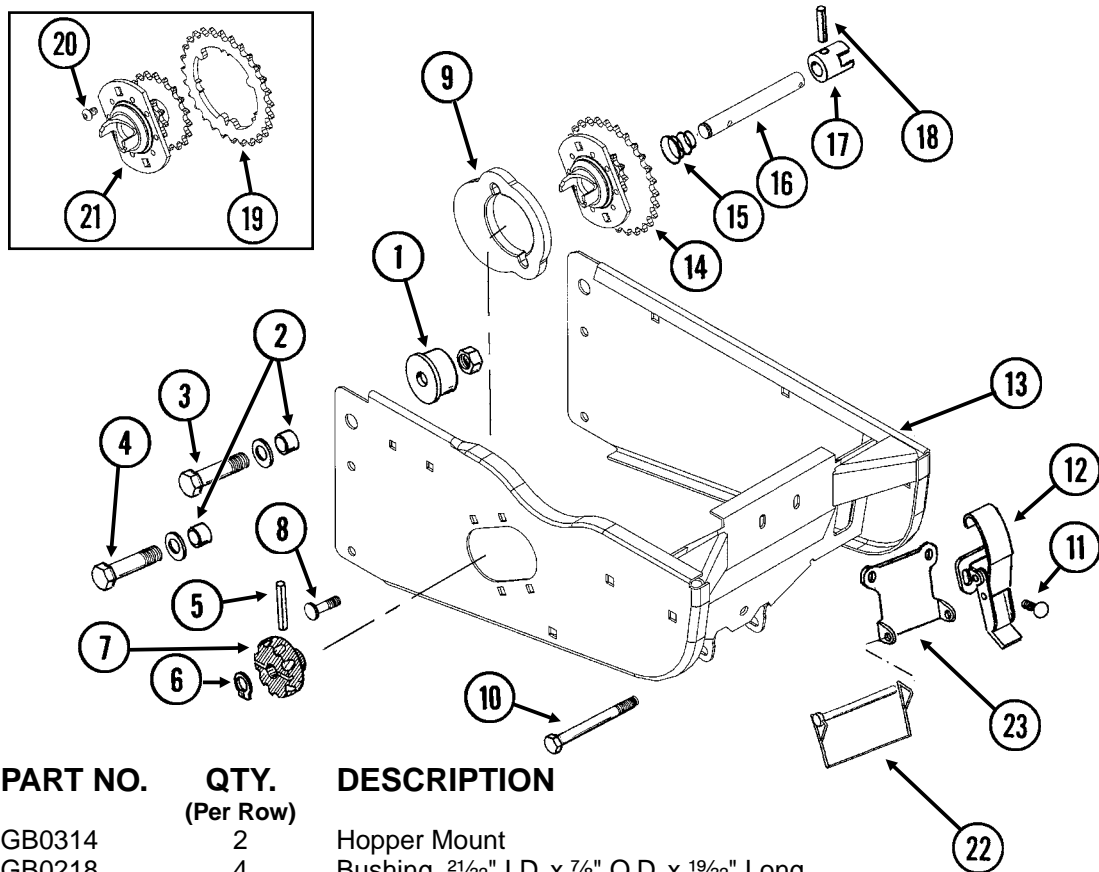

ITEM	PART NO.	QTY. (Per Row)	DESCRIPTION
1.	GB0314	2	Hopper Mount
2.	GB0218	4	Bushing, $2\frac{1}{32}$ " I.D. x $\frac{7}{8}$ " O.D. x $1\frac{19}{32}$ " Long
3.	G10752	2	Hex Head Cap Screw, $\frac{5}{8}$ "-18 x $2\frac{1}{4}$ "
	GD7805	2	Special Washer, $\frac{5}{8}$ ", Hardened
	G10412	2	Lock Nut, $\frac{5}{8}$ "-18
4.	G10751	2	Hex Head Cap Screw, $\frac{5}{8}$ "-18 x $1\frac{3}{4}$ "
	GD7805	2	Special Washer, $\frac{5}{8}$ ", Hardened
	G10412	2	Lock Nut, $\frac{5}{8}$ "-18
5.	G10602	1	Spring Pin, $\frac{1}{4}$ " x $1\frac{1}{2}$ "
6.	G10567	1	External Retaining Ring, $\frac{5}{8}$ "
7.	GD11239	1	Knob
8.	G10338	2	Carriage Bolt, $\frac{5}{16}$ "-18 x $1\frac{1}{4}$ "
	G10620	2	Serrated Flange Nut, $\frac{5}{16}$ "-18
9.	GB0331	1	Clutch Adapter Plate
10.	G10061	1	Hex Head Cap Screw, $\frac{3}{8}$ "-16 x $3\frac{1}{2}$ "
	G10210	2	Washer, $\frac{3}{8}$ " USS
	G10108	1	Lock Nut, $\frac{3}{8}$ "-16
11.	G10309	2	Carriage Bolt, $\frac{1}{4}$ "-20 x $\frac{5}{8}$ ", Grade 2
	G10621	2	Serrated Flange Nut, $\frac{1}{4}$ "-20
12.	GA2007	1	Hopper Hold Down Latch
13.	GA10155	1	Hopper Support
14.	GA12143	1	Double Sprocket And Bearing, Drive Clutch, 11/28 Tooth
15.	GD11413	1	Spring
16.	GD15747	1	Shaft
17.	GB0278	1	Coupler
18.	G10546	1	Spring Pin, $\frac{3}{16}$ " x $1\frac{1}{4}$ "
19.	GD17192	1	Bolt-On Sprocket, 28 Tooth
20.	G11222	3	Hex Socket Button Head Cap Screw, $\frac{5}{16}$ "-18 x $\frac{1}{2}$ ", Stainless Steel
	G10620	3	Serrated Flange Nut, $\frac{5}{16}$ "-18
21.	GA10137	1	Double Sprocket And Bearing, Drive Clutch, 11/19 Tooth
22.	GD10705	1	Locking Clip Pin, $\frac{1}{4}$ " x $2\frac{1}{2}$ " (SDS Only)
23.	GD13110	1	Retainer (SDS Only)
A.	GA12144	-	Meter Drive Assembly, 11/28 Tooth (Items 5-7 And 14-18)

SEED METER MOUNT AND DROP HOSES (SDS)

(D16399/D16485/METR63c/METR63a)

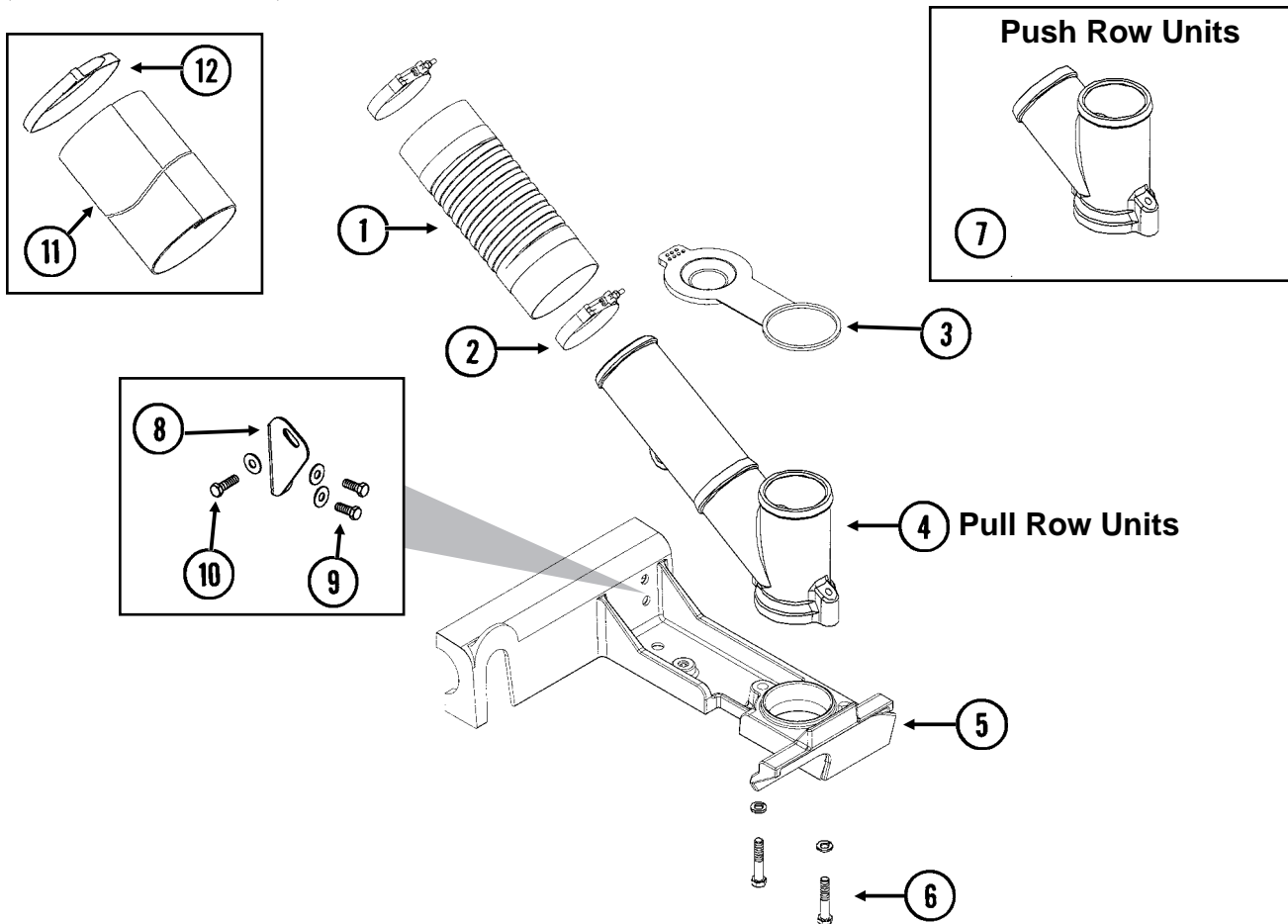

ITEM	PART NO.	QTY. (Per Row)	DESCRIPTION
1.	GD12797-01	-	Drop Hose, 3 1/4" x 34", All Pull Row Units
	GD12797-08	-	Drop Hose, 3 1/4" x 37", Even-Row Push Row Unit And All Push Row Units Except Center And R.H. End Push Row Units
	GD12797-09	-	Drop Hose, 3 1/4" x 39", Center And R.H. End Push Row Units
2.	G10999	2	T-Bolt Hose Clamp, 3 1/4"
3.	GD13412	-	View Cap
4.	GB0375	1	Inlet, Long (Pull Row Units Only)
5.	GA11392	1	Meter Mount
6.	G10047	2	Hex Head Cap Screw, 3/8"-16 x 1 3/4"
	G10229	2	Lock Washer, 3/8"
7.	GB0371	-	Inlet, Short (Push Row Units Only)
8.	GD16485	1	Mount
9.	G10001	2	Hex Head Cap Screw, 3/8"-16 x 1"
	G10210	4	Washer, 3/8" USS
	G10108	2	Lock Nut, 3/8"-16
10.	G10004	1	Hex Head Cap Screw, 3/8"-16 x 1 1/4"
	G10210	2	Washer, 3/8" USS
	G10108	1	Lock Nut, 3/8"-16
11.	GD16399-01	-	Sleeve, 3" x 10"
12.	GD2117	-	Tie Strap, 14 1/2"

NOTE: See "Bulk Seed Hopper Auger Manifold Assembly" on pages P20 and P21 and "Seed Meter" on pages P24 and P25 for additional information.

SEED HOPPER AND LID (Conventional)

(METR12)

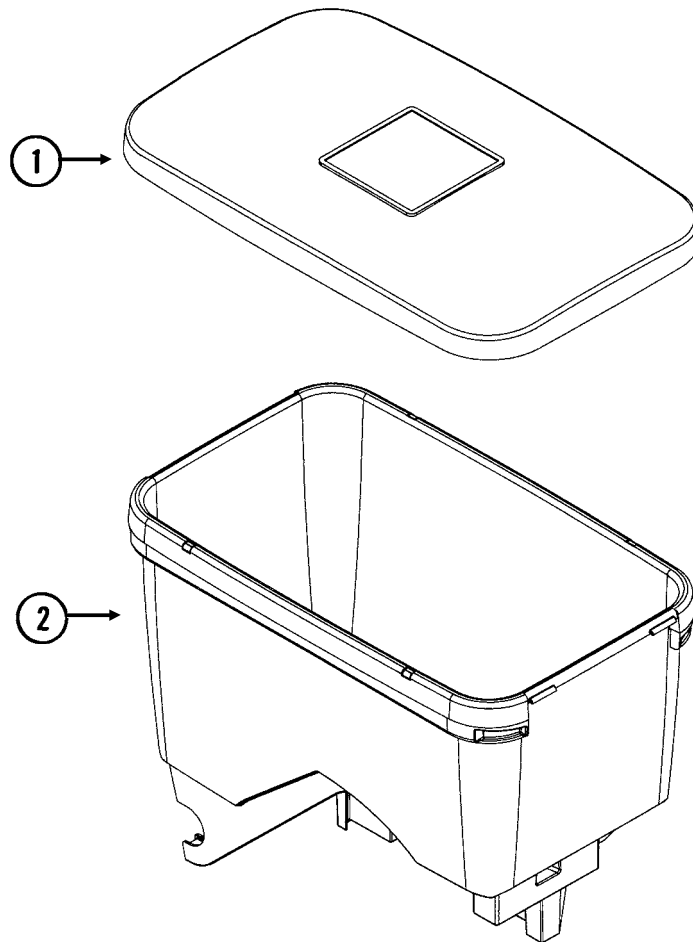

ITEM	PART NO.	QTY.	DESCRIPTION
1.	GD11279	1	Lid
2.	GA10634	1	Seed Hopper

BULK SEED HOPPER CATWALK

(TWL189f/D16509/TWL189ff/TWL189g)

Style A

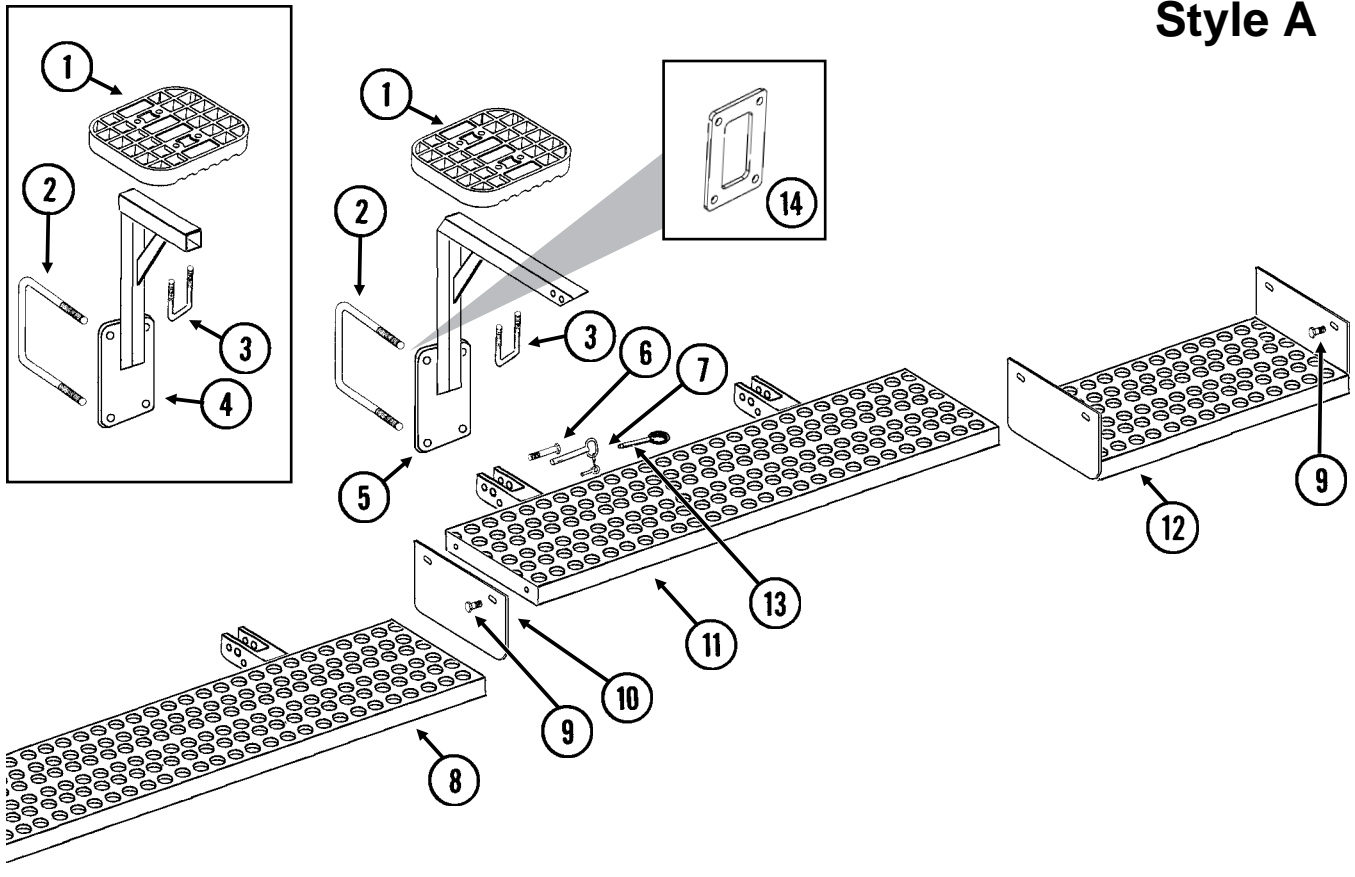

Style B

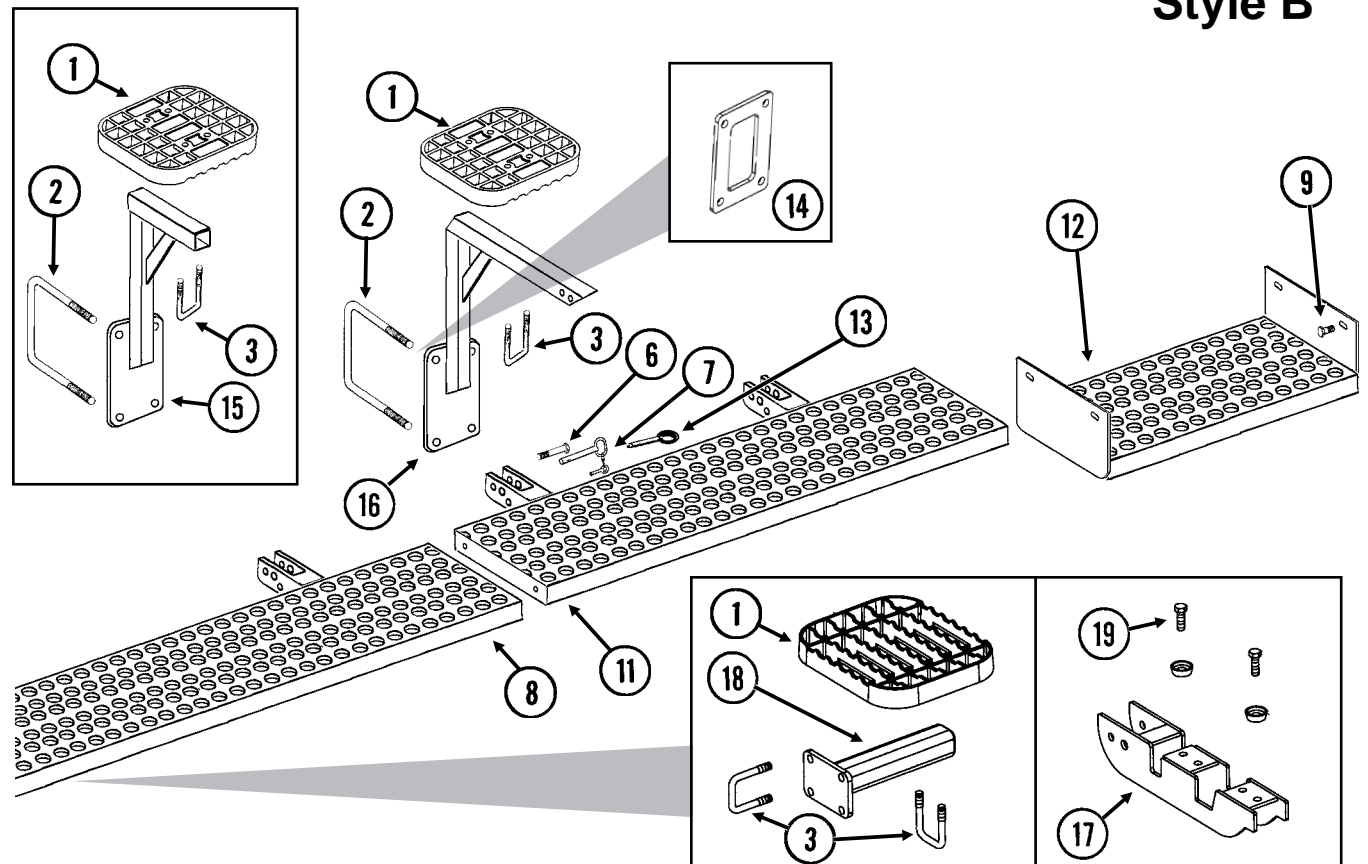

BULK SEED HOPPER CATWALK

ITEM	PART NO.	QTY.	DESCRIPTION
1.	GB0315	9-11	Step
2.	GD1113	-	U-Bolt, 5" x 7" x 5/8"-11
	G10230	-	Lock Washer, 5/8"
	G10104	-	Hex Nut, 5/8"-11
3.	GD2721	-	U-Bolt, 2" x 2" x 1/2"-13
	G10206	-	Washer, 1/2" SAE
	G10111	-	Lock Nut, 1/2"-13
4.	GA10065	2-2	Step Support, 20 1/2", 12 Row 30" Only
5.	GA10066	4-8	Step Support, 20 1/2", 12 Row 30" And 16 Row 30"
	GA10067	4-4	Step Support, 26 1/2", 12 Row 30" And 16 Row 30"
6.	G10033	8-12	Hex Head Cap Screw, 1/2"-13 x 3 1/2"
	G10111	8-12	Lock Nut, 1/2"-13
7.	GA6189	8-12	Hitch Pin
8.	GA9684	2	Catwalk, 96", 12 Row 30"
	GA9685	4	Catwalk, 61", 16 Row 30"
9.	G10338	-	Carriage Bolt, 5/16"-18 x 1 1/4"
	G10219	-	Washer, 5/16" USS
	G10232	-	Lock Washer, 5/16"
	G10106	-	Hex Nut, 5/16"-18
10.	GD14520	2	Plate, 6 1/2" x 11 7/8", 12 Row 30" And 16 Row 30"
11.	GA9682	1	Catwalk, 53", R.H., 12 Row 30" And 16 Row 30"
	GA9683	1	Catwalk, 53", L.H., 12 Row 30" And 16 Row 30" (Shown)
12.	GA10111	1	Center Catwalk, 25", 12 Row 30" And 16 Row 30"
13.	G10874	8-12	Detent Pin, 1/2" x 3 1/2" Grip
14.	GD16509	10-12	Plate
15.	GA12201	3	Step Support, 26 1/2", 12 Row 30" Only
16.	GA10067	8-12	Step Support, 26 1/2", 12 Row 30" And 16 Row 30"
17.	GA12208	1	Hinge Weld, 12 Row 30" Only
18.	GA12207	1	Step Support,
19.	G10017	2	Hex Head Cap Screw, 1/2"-13 x 1 1/2"
	GD17304	2	Washer
	G10111	2	Lock Nut, 1/2"-13

BULK SEED HOPPER ELEVATOR LIFT ASSEMBLY

(TWL299/TWL258a/TWL299b)

L.H. Side Of Planter Shown

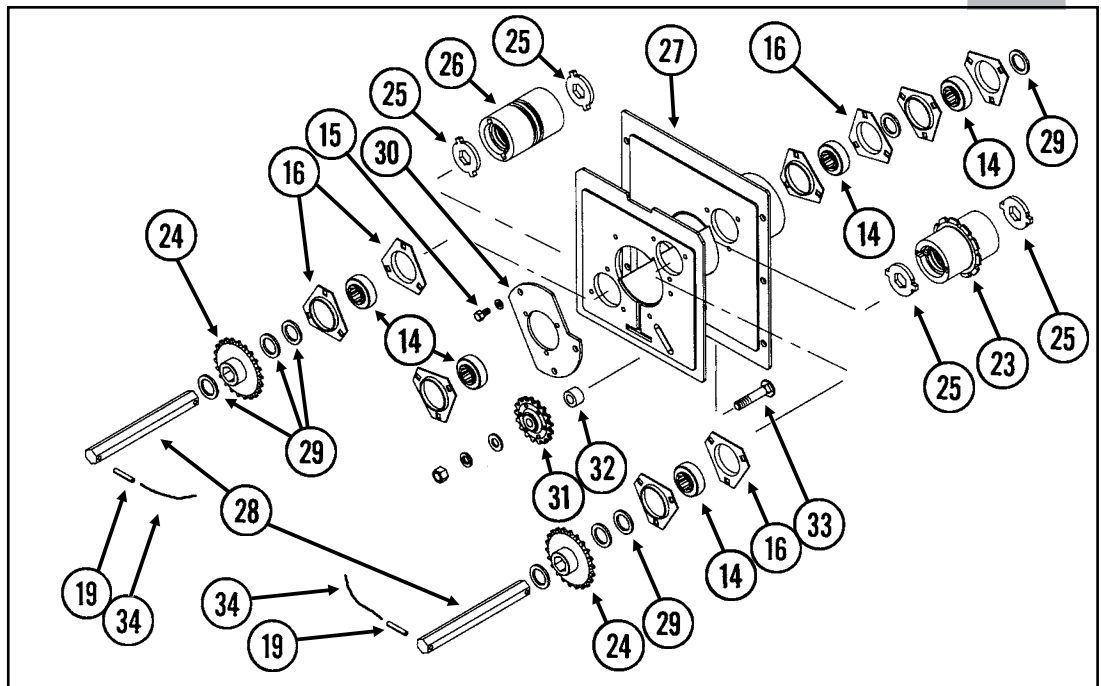
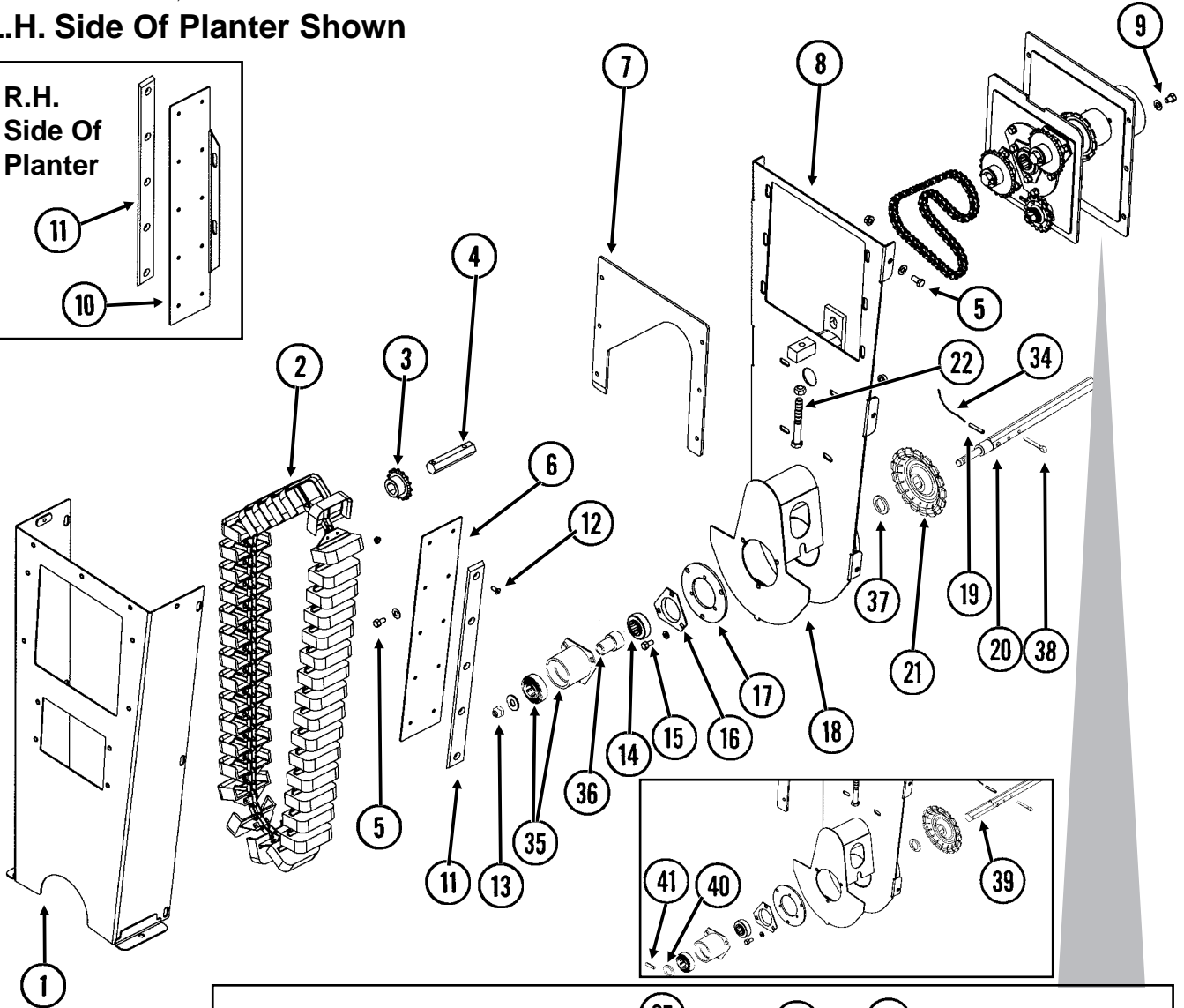
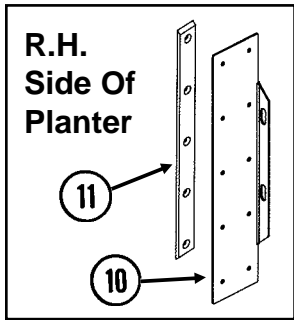

BULK SEED HOPPER ELEVATOR LIFT ASSEMBLY

ITEM	PART NO.	QTY. (Per Hopper)	DESCRIPTION
1.	GA10590	1	Outer Cover
2.	GA10671	1	Elevator Chain Assembly
	G1K398	-	Elevator Bucket W/Connector Links
	GR0194	-	Connector Link, No. 2040
3.	GA5105	1	Sprocket, 15 Tooth
4.	GD15559	1	Hex Shaft, 7/8" x 4 1/4" (2 Holes)
5.	G10002	8	Hex Head Cap Screw, 3/8"-16 x 3/4"
	G10210	20	Washer, 3/8" USS
	G10622	8	Serrated Flange Nut, 3/8"-16
6.	GD15692	1	Guide (R.H. Side Only)
7.	GD15689	1	Mount, L.H. (Shown)
	GD15528	-	Mount, R.H.
8.	G3310-72	1	Chain, No. 40, 72 Pitch Including Connector Link
	GR0912	-	Connector Link, No. 40
9.	G10328	6	Hex Head Cap Screw, 3/8"-16 x 5/8"
	G10210	6	Washer, 3/8" USS
10.	GD15691	1	Guide (L.H. Side Only)
11.	GD15693	2	Wear Pad
12.	G11127	10	Hex Socket Head Cap Screw, 1/4"-20 x 1/2"
	G10621	10	Serrated Flange Nut, 1/4"-20
13.	G10111	1	Lock Nut, 1/2"-13
	G10216	1	Washer, 1/2" USS
14.	GA7841	6	Bearing, 7/8" Hex Bore
15.	G10018	21	Hex Head Cap Screw, 5/16"-18 x 5/8"
	G10232	21	Lock Washer, 5/16"
16.	G3400-01	11	Flangette
17.	GD15694	1	Overlay
18.	GA10985	1	Inner Cover
19.	G10602	6	Spring Pin, 1/4" x 1 1/2"
20.	GA11916	1	Inner Profile, 14 5/8"
21.	GD15746	1	Special Sprocket, 17 Tooth
22.	G10890	1	Hex Head Adjusting Bolt, 1/2"-13 x 4", Grade 2
	G10501	1	Hex Jam Nut, 1/2"-13, Grade 2
23.	GB0352	1	Sprocket, 11 Tooth
24.	GA5108	2	Sprocket, 23 Tooth
25.	GD15733	4	Drive Plate
26.	GB0353	1	Idler
27.	GA10591	1	Drive Plate, L.H. (Shown)
	GA10592	-	Drive Plate, R.H.
28.	GD15526	2	Hex Shaft, 7/8" x 8 3/8" (2 Holes)
29.	G10233	8	Machine Bushing, 1", 10 Gauge
30.	GD15695	1	Access Overlay
31.	GA7154	1	Sprocket W/Bearing, 18 Tooth
32.	GD4887-01	1	Sleeve, 1/2" I.D. x 5/8" Long
33.	G10315	1	Carriage Bolt, 1/2"-13 x 2 1/2"
	G10206	1	Washer, 1/2" SAE
	G10228	1	Lock Washer, 1/2"
	G10102	1	Hex Nut, 1/2"-13
34.	GD13524-01	6	Lock Wire, 10", Stainless Steel
35.	GA5223	1	Spacer W/Bearing
	GA5116	-	Bearing, 7/8" Hex Bore, Cylindrical
36.	GD16120	1	Spacer
37.	GD16397	1	Special Washer
38.	G10463	1	Cotter Pin, 1/4" x 1 1/2"
39.	GA12510	1	Shaft Assembly W/Spring Pin, 14 1/2"
	G10473	-	Spring Pin, 5/16" x 1 1/4"
40.	G10233	1	Machine Bushing, 1", 10 Gauge
41.	G10473	1	Spring Pin, 5/16" x 1 1/4"

BULK SEED HOPPER AND HYDRAULIC MOTOR DRIVE

(TWL300/TWL190h/TWL190e)

R.H. Side Of Planter - 12 Row 30" Shown

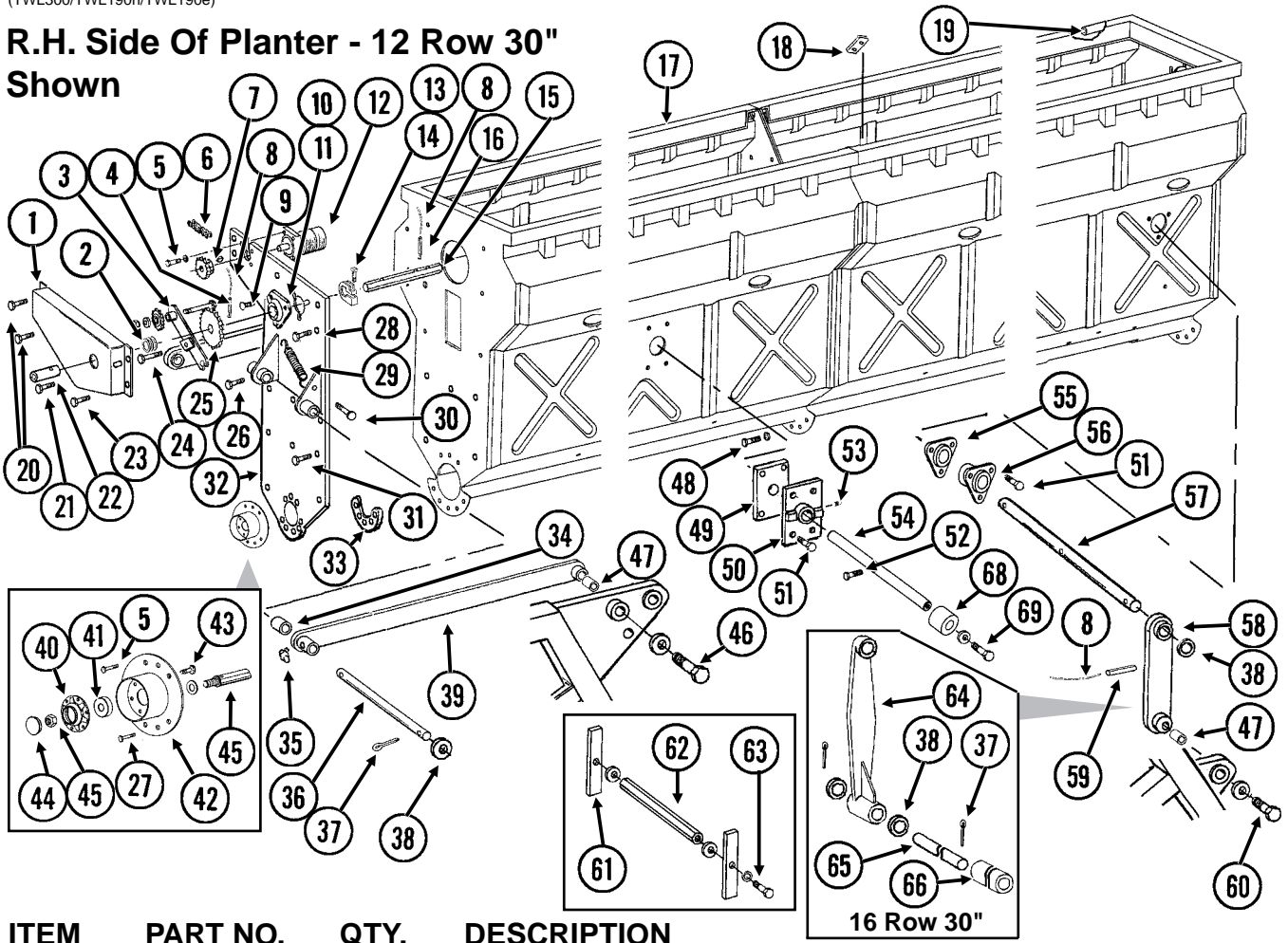

ITEM	PART NO.	QTY.	DESCRIPTION
		(Per Hopper)	
1.	GD13122	1	Cover, R.H.
	GD13123	-	Cover, L.H.
2.	G10233	3	Machine Bushing, 1", 10 Gauge
3.	GA9554	1	Idler W/Sprocket And Hardware (Shown)
	GA9553	-	Idler W/Sprocket And Hardware
	GA7154	-	Sprocket W/Bearing, 18 Tooth
	G10017	-	Hex Head Cap Screw, 1/2"-13 x 1 1/2"
	G10128	-	Machine Bushing, 1/2", 14 Gauge
	G10501	-	Hex Jam Nut, 1/2"-13, Grade 2
4.	G10602	1	Spring Pin, 1/4" x 1 1/2"
5.	G10001	7	Hex Head Cap Screw, 3/8"-16 x 1"
	G10229	7	Lock Washer, 3/8"
6.	G3310-88	1	Chain, No. 40, 88 Pitch Including Connector Link
	GR0912	-	Connector Link, No. 40
7.	GA9625	1	Sprocket, 20 Tooth
8.	GD13524-01	-	Lock Wire, 10", Stainless Steel
9.	G10312	3	Carriage Bolt, 5/16"-18 x 3/4"
	G10923	3	Flange Nut, 5/16"-18, No Serration
10.	G3400-01	2	Flangette
11.	GA7841	1	Bearing, 7/8" Hex Bore
12.	GA9395	1	Hydraulic Motor
	GR1558	-	Seal Kit (Eaton), Includes: (6) Seals, (1) BU Ring, (3) O-Rings, (7) Seal Washers
	GR1637	-	Seal Kit (TCI), Includes: (2) Seals, (1) Ring, (4) O-Rings
13.	GD11045	1	Lock Clamp
14.	G10130	1	Square Head Machine Bolt, 5/16"-18 x 1 3/4"
	G10923	1	Flange Nut, 5/16"-18, No Serration
15.	GD13460	1	Hex Shaft, 7/8" x 7 3/4" (2 Holes)
16.	G10606	2	Spring Pin, 1/4" x 2"
17.	-	-	See "Bulk Seed Hopper And Auger Assemblies, Pages P22 And P23"
18.	GD13570	2	Plate, 1 1/2" x 2 1/2"
19.	GD13575-04	2	Reinforcement Tube, 1" O.D. x 137", 12 Row 30"
	GD13575-03	2	Reinforcement Tube, 1" O.D. x 207 1/2", 16 Row 30"
20.	G10001	3	Hex Head Cap Screw, 3/8"-16 x 1"
	G10622	3	Serrated Flange Nut, 3/8"-16

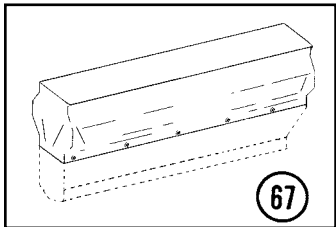

BULK SEED HOPPER AND HYDRAULIC MOTOR DRIVE

ITEM	PART NO.	QTY.	DESCRIPTION
		(Per Hopper)	
21.	G10004	1	Hex Head Cap Screw, 3/8"-16 x 1 1/4"
	G11017	1	Flange Nut, 3/8"-16
22.	GD13554	1	Coupler, 3 1/4"
23.	G10004	2	Hex Head Cap Screw, 3/8"-16 x 1 1/4"
	G10622	2	Serrated Flange Nut, 3/8"-16
24.	G10036	1	Hex Head Cap Screw, 5/8"-11 x 4"
	G10104	1	Hex Nut, 5/8"-11
	G10107	1	Lock Nut, 5/8"-11
25.	GA7180	1	Sprocket, 40 Tooth
26.	G10004	2	Hex Head Cap Screw, 3/8"-16 x 1 1/4"
	G10201	2	Special Washer, 3/8" x 1 1/2" O.D.
	G10622	2	Serrated Flange Nut, 3/8"-16
27.	G10003	5	Hex Head Cap Screw, 3/8"-16 x 1 1/2"
	G10108	5	Lock Nut, 3/8"-16
28.	G10001	4	Hex Head Cap Screw, 3/8"-16 x 1"
	G10622	4	Serrated Flange Nut, 3/8"-16
29.	GD5857	1	Spring
30.	G10870	1	Clevis Pin, 3/8" x 1"
	G10860	1	Retaining Ring, 3/8"
31.	G11017	8	Flange Nut, 3/8"-16
	G10001	8	Hex Head Cap Screw, 3/8"-16 x 1"
32.	GA9157	1	Hopper Mount, L.H.
	GA9158	-	Hopper Mount, R.H.
33.	GD13555	3	Tie Plate
34.	GD0752-41	2	Sleeve, 1"
35.	G10779	2	Grease Fitting, 90°, 1/4"-28
36.	GD13143	1	Pin, 1 1/4" x 26"
37.	G10460	4	Cotter Pin, 1/4" x 2"
38.	G10979	8	Special Washer, 1 1/4"
39.	GA9160	2	Link, 52"
40.	GD10473	1	Bearing Housing
41.	GA9977	1	Bearing
42.	GA9848	1	End Cap
43.	G10020	6	Hex Head Cap Screw, 1/4"-20 x 5/8"
	G10110	6	Lock Nut, 1/4"-20, Grade B
44.	GD11845	1	Dust Cap
45.	GA11962	1	Inner Profile, 5 1/2"
	G10205	1	Washer, 5/8" SAE
	G10107	1	Lock Nut, 5/8"-11
46.	G11027	2	Hex Head Cap Screw, 7/8"-9 x 4"
	G10659	2	Washer, 7/8" USS
47.	GD2734-13	4	Sleeve, 1 1/4" O.D. x 3 1/8" Long
48.	G10047	-	Hex Head Cap Screw, 3/8"-16 x 1 3/4"
	G10108	-	Lock Nut, 3/8"-16
49.	GD13227	2	Plate, 4" x 6"
50.	GB0307	-	Plate
51.	G10003	-	Hex Head Cap Screw, 3/8"-16 x 1 1/2"
	G10622	-	Serrated Flange Nut, 3/8"-16
52.	G10049	1	Hex Head Cap Screw, 3/8"-16 x 2 1/2"
	G10108	1	Lock Nut, 3/8"-16
53.	G10640	-	Grease Fitting, 1/4"-28
54.	GD15888	1	Pin, 1 1/4" x 20"
55.	GD15743	-	Plate
56.	GA10699	1	Mount
57.	GD13144	1	Pin, 1 1/4" x 20 1/2"
58.	GA10731	2	Link, 15", 12 Row 30"
59.	G10600	2	Spring Pin, 5/16" x 2 1/4"
60.	G10417	4	Hex Head Cap Screw, 7/8"-9 x 4 1/2"
	G10659	4	Washer, 7/8" USS
61.	GD14056	4	Bar, 1" x 8"
62.	GD14057	2	Hex Shaft, 7/8" x 12"
63.	G10016	4	Hex Head Cap Screw, 1/2"-13 x 2"
	G10228	4	Lock Washer, 1/2"
	G10216	4	Washer, 1/2" USS
64.	GB0308	2	Link, 18", 16 Row 30"
65.	GD14500	1	Pin, 1 1/4" x 26 1/2"
66.	GD2725-09	1	Pipe, 1 1/4" x 10"
67.	G1K338	1	Hopper Cover Kit, 12 Row 30", Includes: (1) L.H. Bulk Seed Hopper Cover, (1) R.H. Bulk Seed Hopper Cover
	G1K339	1	Hopper Cover Kit, 16 Row 30", Includes: (1) L.H. Bulk Seed Hopper Cover, (1) R.H. Bulk Seed Hopper Cover
68.	GD15887	2	Sleeve, 2 1/4" Long
69.	G10007	2	Hex Head Cap Screw, 5/8"-11 x 1 1/2"
	G10217	2	Washer, 5/8" USS
A.	GA9859	-	Bearing Cap Assembly (Items 40-45)

BULK SEED HOPPER LID

(TWL257)

L.H. Side Of Planter Shown

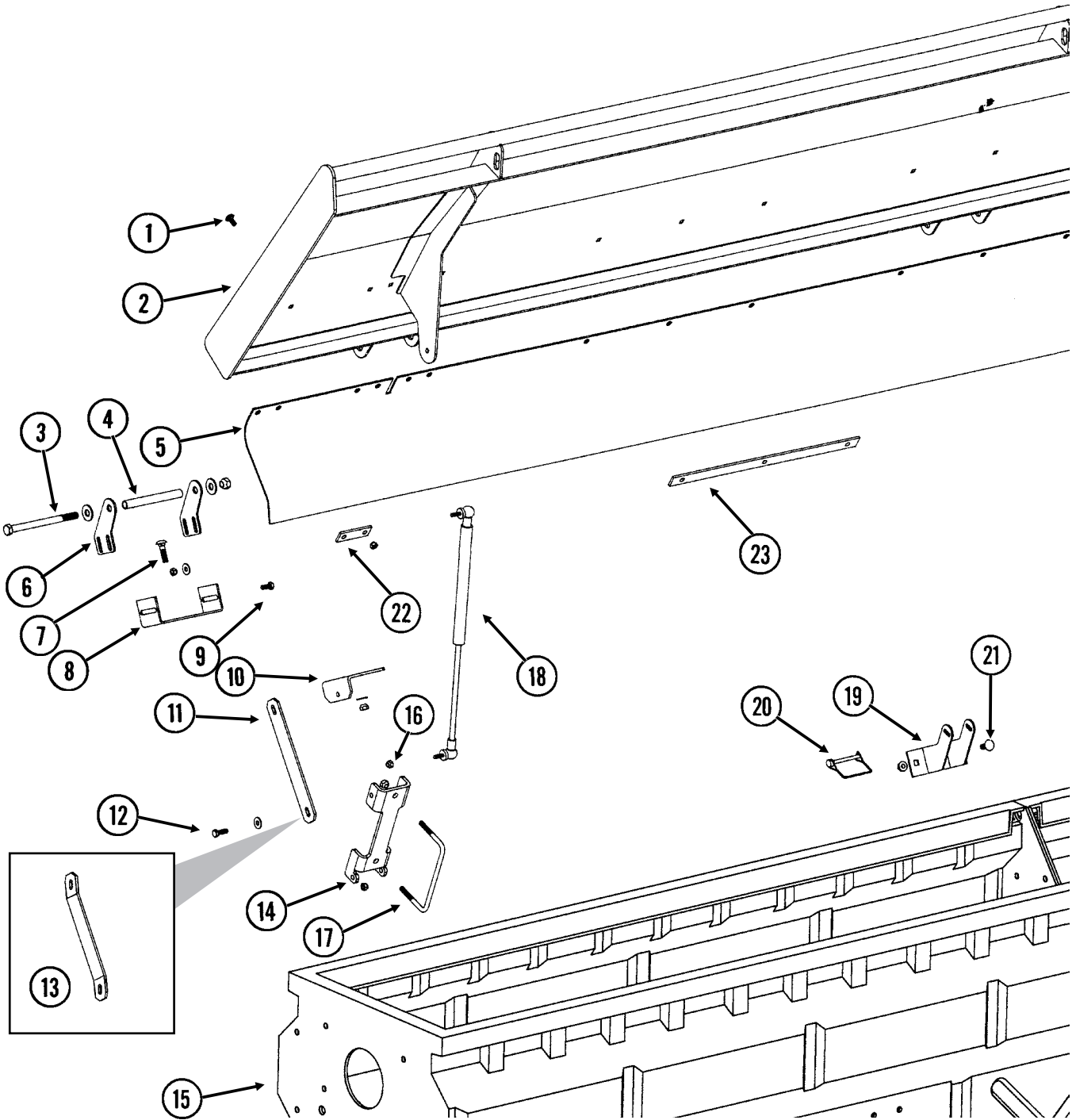

BULK SEED HOPPER LID

ITEM	PART NO.	QTY. (Per Hopper)	DESCRIPTION
1.	G10312	-	Carriage Bolt, 5/16"-18 x 3/4"
	G10109	-	Lock Nut, 5/16"-18, Grade 8
2.	GA10722	1	Hopper Lid, R.H., 12 Row 30"
	GA10721	1	Hopper Lid, L.H., 12 Row 30"
	GA10580	-	Hopper Lid, R.H., 16 Row 30"
	GA10581	-	Hopper Lid, L.H., 16 Row 30"
3.	G10829	3-4	Hex Head Cap Screw, 1/2"-13 x 6 1/2"
	G10216	6-8	Washer, 1/2" USS
	G10217	8	Washer, 5/8" USS
	G10111	3-4	Lock Nut, 1/2"-13
4.	GD7904-05	3	Sleeve, 5 3/8" Long
5.	GD15766	1	Splash Guard Strip, 12 Row 30"
	GD15482	-	Splash Guard Strip, 16 Row 30"
6.	GD13595	6-8	Hinge Tab
7.	G10301	12	Carriage Bolt, 3/8"-16 x 1 1/2"
	G10210	12	Washer, 3/8" USS
	G10108	12	Lock Nut, 3/8"-16
8.	GD15737	3-4	Hinge Plate
9.	G10043	12-16	Hex Head Cap Screw, 5/16"-18 x 3/4"
	G10219	24-32	Washer, 5/16" USS
	G10109	12-16	Lock Nut, 5/16"-18, Grade 8
10.	GD15738	2	Bracket
11.	GD13152	1-2	Brace
12.	G10019	4	Hex Head Cap Screw, 5/16"-18 x 1"
	G10219	4	Washer, 5/16" USS
	G10923	4	Flange Nut, 5/16"-18, No Serration
13.	GD15748	1	Brace, 16 Row 30" Only
14.	GD13198	2	Spring Anchor
15.		-	See "Bulk Seed Hopper And Auger Assemblies", Pages P22 And P23
16.	G10109	-	Lock Nut, 5/16"-18, Grade 8
17.	GD13491	2	U-Bolt, 2" x 6" x 3/8"-16
	G10108	4	Lock Nut, 3/8"-16
18.	GA9404	2	Gas Spring, 134 Pounds
19.	GA9588	1	Latch
20.	GD10705	1	Locking Clip Pin, 1/4" x 2 1/2"
21.	G10305	2	Carriage Bolt, 3/8"-16 x 1"
	G11017	2	Flange Nut, 3/8"-16
22.	GD13470	8	Retainer, 1" x 3"
23.	GD12847	2	Retainer, 1" x 18"

BULK SEED HOPPER AUGER MANIFOLD ASSEMBLY

L.H. Side Of Planter Shown

(TWL261aa)

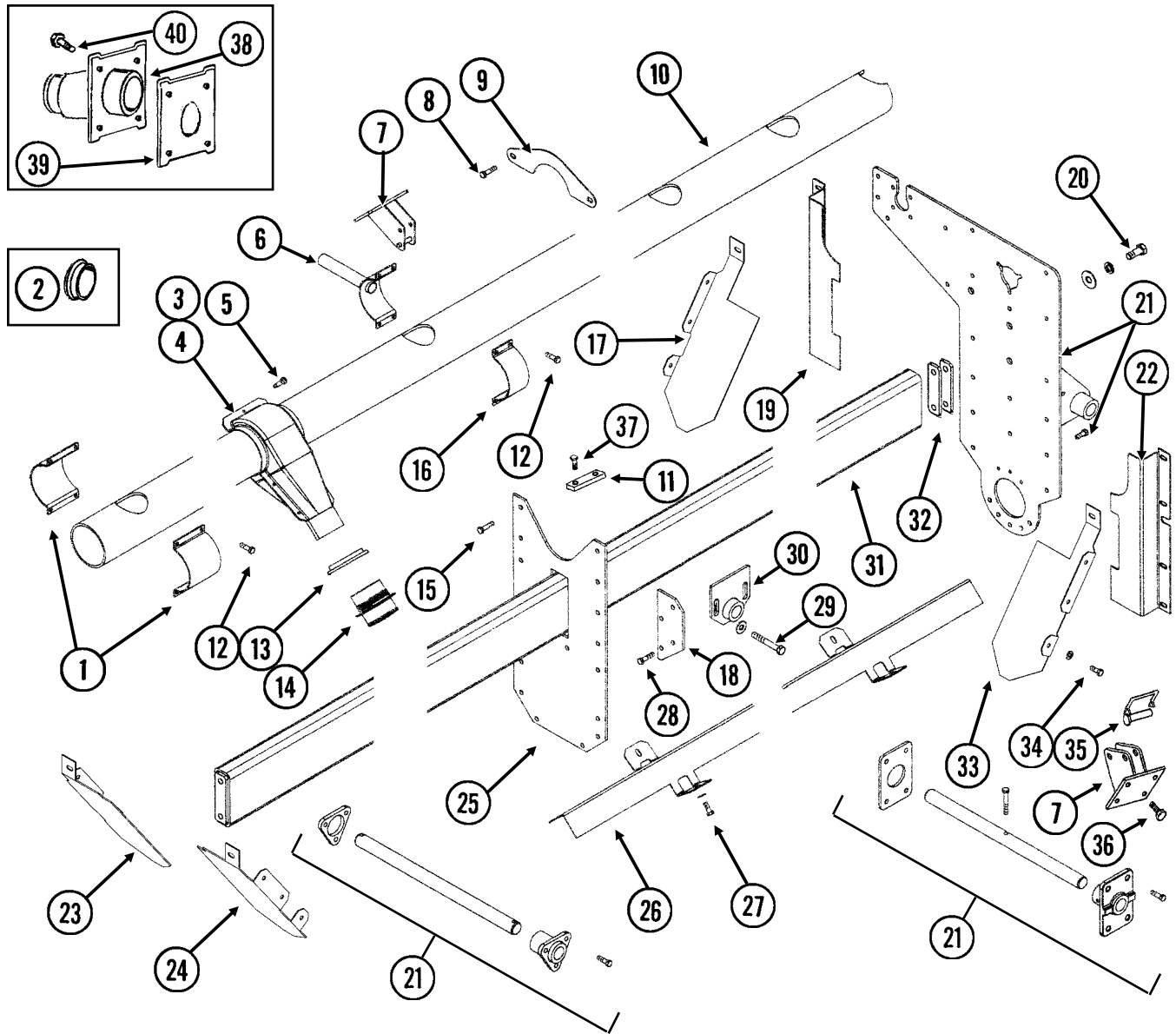

BULK SEED HOPPER AUGER MANIFOLD ASSEMBLY

ITEM	PART NO.	QTY. (Per Hopper)	DESCRIPTION
1.	GD15757	2	Clamp
2.	G11000	-	Cap, 3"
3.	GD11968	-	Funnel, Top
4.	GA9621	-	Funnel, Bottom
5.	G11020	1	Phillips Pan Head Machine Screw, No. 10-24
6.	GA9159	1	Handle
7.	GA9196	2	Latch
8.	G10003	2	Hex Head Cap Screw, 3/8"-16 x 1 1/2"
	G10622	2	Serrated Flange Nut, 3/8"-16
9.	GD14058	1-2	Bracket
10.	GD16173	1	Distribution Manifold, 140", L.H., 12 Row 30"
	GD15744	-	Distribution Manifold, 140", R.H., 12 Row 30"
	GD15471	-	Distribution Manifold, 210 1/2", L.H., 16 Row 30"
	GD15470	-	Distribution Manifold, 189", R.H., 16 Row 30"
11.	GD13628	1	Tap Block, 1" x 4"
12.	G10043	4	Hex Head Cap Screw, 5/16"-18 x 3/4"
	G10109	4	Lock Nut, 5/16"-18, Grade 8
13.	GB0313	12-16	Nut, 3 1/4"-12
14.	GB0312	12-16	Nipple
15.	G10003	13	Hex Head Cap Screw, 3/8"-16 x 1 1/2"
	G11017	13	Flange Nut, 3/8"-16
16.	GD13183	1	Clamp
17.	GD13125	1	Baffle, L.H.
18.	GD13120	4	Tie Bar
19.	GD13126	1	Baffle, R.H.
20.	G10010	2	Hex Head Cap Screw, 5/8"-11 x 3"
	G10217	2	Washer, 5/8" USS
	G10230	2	Lock Washer, 5/8"
21.		-	See "Bulk Seed Hopper And Hydraulic Motor Drive", Pages P16 And P17
22.	GD13127	1	Baffle, L.H.
23.	GD15535	1	Baffle
24.	GD15534	1	Baffle
25.	GD13571	2	Tie Plate, 16 Row 30"
26.	GD13138	2	Tunnel Cover
27.	G10001	-	Hex Head Cap Screw, 3/8"-16 x 1"
	G10210	-	Washer, 3/8" USS
	G11017	-	Flange Nut, 3/8"-16
28.	G10003	-	Hex Head Cap Screw, 3/8"-16 x 1 1/2"
	G10622	-	Serrated Flange Nut, 3/8"-16
29.	G10033	-	Hex Head Cap Screw, 1/2"-13 x 3 1/2"
	G10216	-	Washer, 1/2" USS
	G10111	-	Lock Nut, 1/2"-13
30.	GA9175	2	Support
31.	GA10725	1	Support Tube, 140 1/2", 12 Row 30"
	GA10579	-	Support Tube, 211", 16 Row 30"
32.	GD13576	-	Shim, 1 3/8" x 5 3/8", 10 Gauge (As Required)
	GD13577	-	Shim, 1 3/8" x 5 3/8", 1/4" Thick (As Required)
33.	GD13124	-	Baffle Plate, R.H.
34.	G10001	8	Hex Head Cap Screw, 3/8"-16 x 1"
	G10210	8	Washer, 3/8" USS
	G10622	8	Serrated Flange Nut, 3/8"-16
35.	GD10705	2	Locking Clip Pin, 1/4" x 2 1/2"
36.	G10001	8	Hex Head Cap Screw, 3/8"-16 x 1"
	G10210	8	Washer, 3/8" USS
	G11017	8	Flange Nut, 3/8"-16
37.	G10017	2	Hex Head Cap Screw, 1/2"-13 x 1 1/2"
	G10102	2	Hex Nut, 1/2"-13
38.	GA10764	1	Drop Tube
39.	GD15812	1	Plate
40.	G10019	4	Hex Head Cap Screw, 5/16"-18 x 1"
	G10923	4	Flange Nut, 5/16"-18, No Serration

BULK SEED HOPPER AND AUGER ASSEMBLIES

(TWL259b)

L.H. Side Of Planter Shown

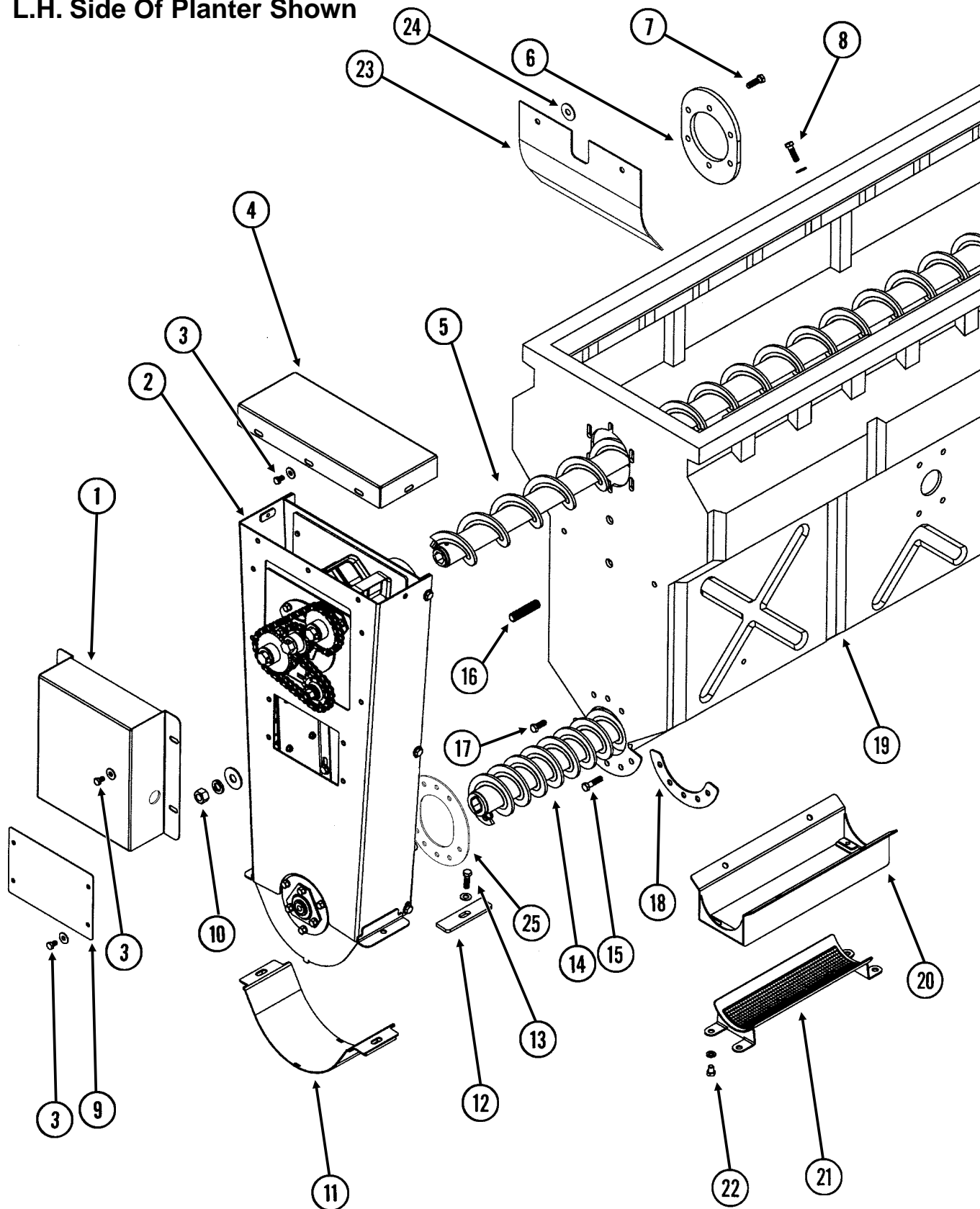

BULK SEED HOPPER AND AUGER ASSEMBLIES



ITEM	PART NO.	QTY. (Per Hopper)	DESCRIPTION
1.	GD15530	1	Cover
2.		-	See "Bulk Seed Hopper Elevator Lift Assembly", Pages P14 And P15
3.	G10054	13	Hex Head Cap Screw, 5/16"-18 x 1/2"
	G10219	13	Washer, 5/16" USS
4.	GD15529	1	Cover
5.	GA9191	1	Top Auger, L.H., 147 1/2", 12 Row 30"
	GA9192	-	Top Auger, R.H., 147 1/2", 12 Row 30"
	GA9193	-	Top Auger, L.H., 217 1/2", 16 Row 30"
	GA9194	-	Top Auger, R.H., 217 1/2", 16 Row 30"
6.	GD15525	1	Flange
7.	G10004	6	Hex Head Cap Screw, 3/8"-16 x 1 1/4"
8.	G10004	4	Hex Head Cap Screw, 3/8"-16 x 1 1/4"
	G10210	8	Washer, 3/8" USS
	G10108	4	Lock Nut, 3/8"-16
9.	GD15531	1	Cover
10.	G10217	2	Washer, 5/8" USS
	G10230	2	Lock Washer, 5/8"
	G10104	2	Hex Nut, 5/8"-11
11.	GA10688	1	Cover
12.	GD15735	2	Plate, 1 1/4" x 4 3/4"
13.	G10004	2	Hex Head Cap Screw, 3/8"-16 x 1 1/4"
	G10210	2	Washer, 3/8" USS
	G10622	2	Serrated Flange Nut, 3/8"-16
14.	GA10971	1	Floor Auger, L.H., 144 3/4", 12 Row 30"
	GA10972	-	Floor Auger, R.H., 144 3/4", 12 Row 30"
	GA10969	-	Floor Auger, L.H., 215 1/4", 16 Row 30"
	GA10964	-	Floor Auger, R.H., 215 1/4", 16 Row 30"
15.	G10003	5	Hex Head Cap Screw, 3/8"-16 x 1 1/2"
	G10108	5	Lock Nut, 3/8"-16
16.	GD15756	2	Stud, 5/8"-11 x 2 3/4"
17.	G10001	3	Hex Head Cap Screw, 3/8"-16 x 1"
	G11017	3	Flange Nut, 3/8"-16
18.	GD13555	1	Tie Plate
19.	GD15466	1	Inner Hopper Section, R.H., 12 Row 30" And 16 Row 30"
	GD16162	1	Outer Hopper Section, R.H., 12 Row 30" And 16 Row 30"
	GD15467	1	Inner Hopper Section, L.H., 12 Row 30" And 16 Row 30"
	GD16163	1	Outer Hopper Section, L.H., 12 Row 30" And 16 Row 30"
	GD15465	1	Center Hopper Section, R.H. And L.H., 16 Row 30"
20.	GA10583	1	Mount
21.	GA10587	1	Screen
22.	G10018	4	Hex Head Cap Screw, 5/16"-18 x 5/8"
	G10229	4	Lock Washer, 3/8"
23.	GD16193	1	Rubber Baffle
24.		-	See Item 26 On Pages P16 And P17
25.	GD16174	1	Flange

SEED METER

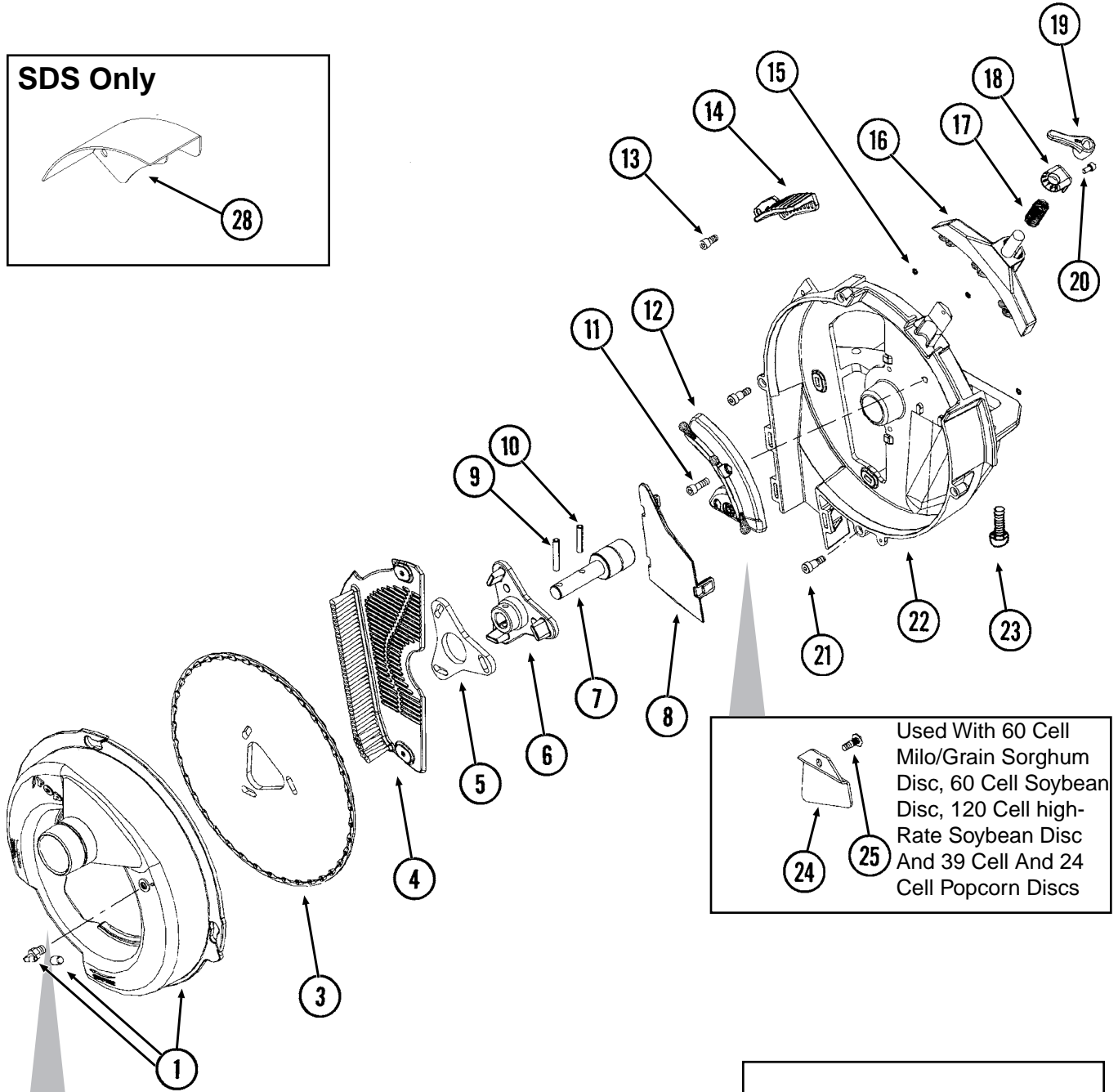
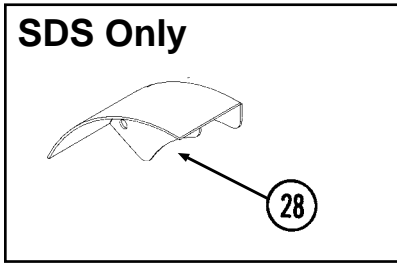
(METR69/METR65/A12133)



Used With 60 Cell Milo/Grain Sorghum Disc, 60 Cell Soybean Disc, 120 Cell high-Rate Soybean Disc And 39 Cell And 24 Cell Popcorn Discs

	<p>2 Used With 60 Cell Milo/Grain Sorghum Disc</p>
	<p>27 Used With 20 Cell Hill-Drop Acid-Delinted Cotton Discs And 54 Cell Acid-Delinted Cotton/ Small Dry Edible Bean Disc</p>

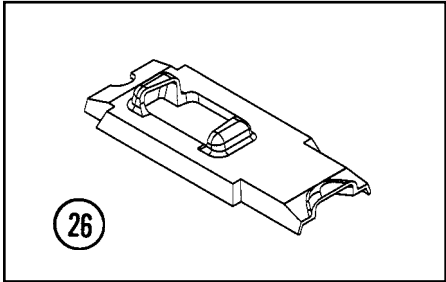

SEED METER

ITEM	PART NO.	QTY.	DESCRIPTION
1.	GA11911	1	Vacuum Cover W/Elbow And Cap
	GD17099	-	3/16" Hose Barb Elbow
	GD17152	-	Cap
2.	GA12133	1	Cleanout Brush (Used With 60 Cell Milo/Grain Sorghum Disc)
3.	GD17049	-	Seed Disc, Corn/Popcorn, 39 Cell, Light Blue Color-Coded
	GD17048	-	Seed Disc, Low-Rate Corn/Popcorn, 24 Cell, Light Green Color-Coded
	GD14467	-	Seed Disc, Soybean, 60 Cell, Black Color-Coded
	GD14468	-	Seed Disc, High-Rate Soybean, 120 Cell, Dark Blue Color-Coded
	GD17050	-	Seed Disc, Milo/Grain Sorghum, 60 Cell, Yellow Color-Coded
	GD17187	-	Seed Disc, Hill-Drop Cotton, Acid-Delinted, 20 Cell (3 Seeds Per Cell), Brown Color-Coded
	GD18095	-	Seed Disc, Small Hill-Drop Cotton, Acid-Delinted, 20 Cell (3 Seeds Per Cell), Grey Color-Coded
	GD17186	-	Seed Disc, Cotton, Acid-Delinted/Small Dry Edible Bean, 54 Cell, Dark Green Color-Coded
	GD14477	-	Seed Disc, Large Dry Edible Bean, 54 Cell, Tan Color-Coded
4.	GD17028	1	Wall Brush/Vent
5.	GD17021	1	Foam Spacer
6.	GB0328	1	Mount
7.	GA5698	1	Bearing
8.	GD14541	1	Discharge Cover
9.	G10602	1	Spring Pin, 1/4" x 1 1/2"
10.	G10603	1	Spring Pin, 1/4" x 1 1/4"
11.	G11213	1	Hex Socket Head Cap Screw, 1/4"-20 x 3/4"
12.	GA11935	1	Crowder Brush
13.	G10260	1	Hex Socket Head Cap Screw, 1/4"-20 x 1/2" (Conventional Planters)
	G10252	1	Hex Socket Head Cap Screw, 1/4"-20 x 7/8" (SDS Planters)
	G10209	1	Washer, 1/4" USS (SDS Planters)
	G10110	1	Lock Nut, 1/4"-20, Grade B (SDS)
14.	GD17047	1	Air Inlet Screen
15.	GD17162	3	Push Nut, 1/8" I.D.
16.	GA10755	1	Singulator Brush
17.	GD14592	1	Spring
18.	GB0358	1	Cap
19.	GD15663	1	Brush Adjustment Lever
20.	G11173	1	Hex Socket Head Cap Screw, No. 10-24 x 3/8", Stainless Steel
21.	G11172	4	Hex Socket Head Shoulder Screw, 1/4"-20 x 3/8", Stainless Steel
22.	GB0319	1	Housing
23.	G11009	2	Locking Thumbscrew, 5/16"-18 x 3/4" (Conventional Planters)
	G10171	2	Hex Head Cap Screw, 5/16"-18 x 1 1/4" (SDS Planters)
	G10232	2	Lock Washer, 5/16" (SDS)
24.	GD17104	1	Seed Baffle (Used With 60 Cell Milo/Grain Sorghum Disc And 60 Cell Soybean Disc, 120 Cell High-Rate Soybean Disc And 39 Cell And 24 Cell Popcorn Discs)
25.	G11210	1	Rib Neck Bolt, 1/4"-20 x 3/4"
	G10323	1	Hex Flange Nut, 1/4"-20, No Serration
26.	GD15700	1	Shank Cover, EdgeVac® Meter
27.	GA12154	-	Cleanout Brush W/Ball-Type Ejector (Used With 20 Cell Hill-Drop Acid-Delinted Cotton Discs And 54 Cell Acid-Delinted Cotton/Small Dry Edible Bean Discs)
28.	GD15923	1	Meter Cover (SDS Only)

GRANULAR CHEMICAL HOPPER AND HOPPER PANEL EXTENSION

(METR14d)

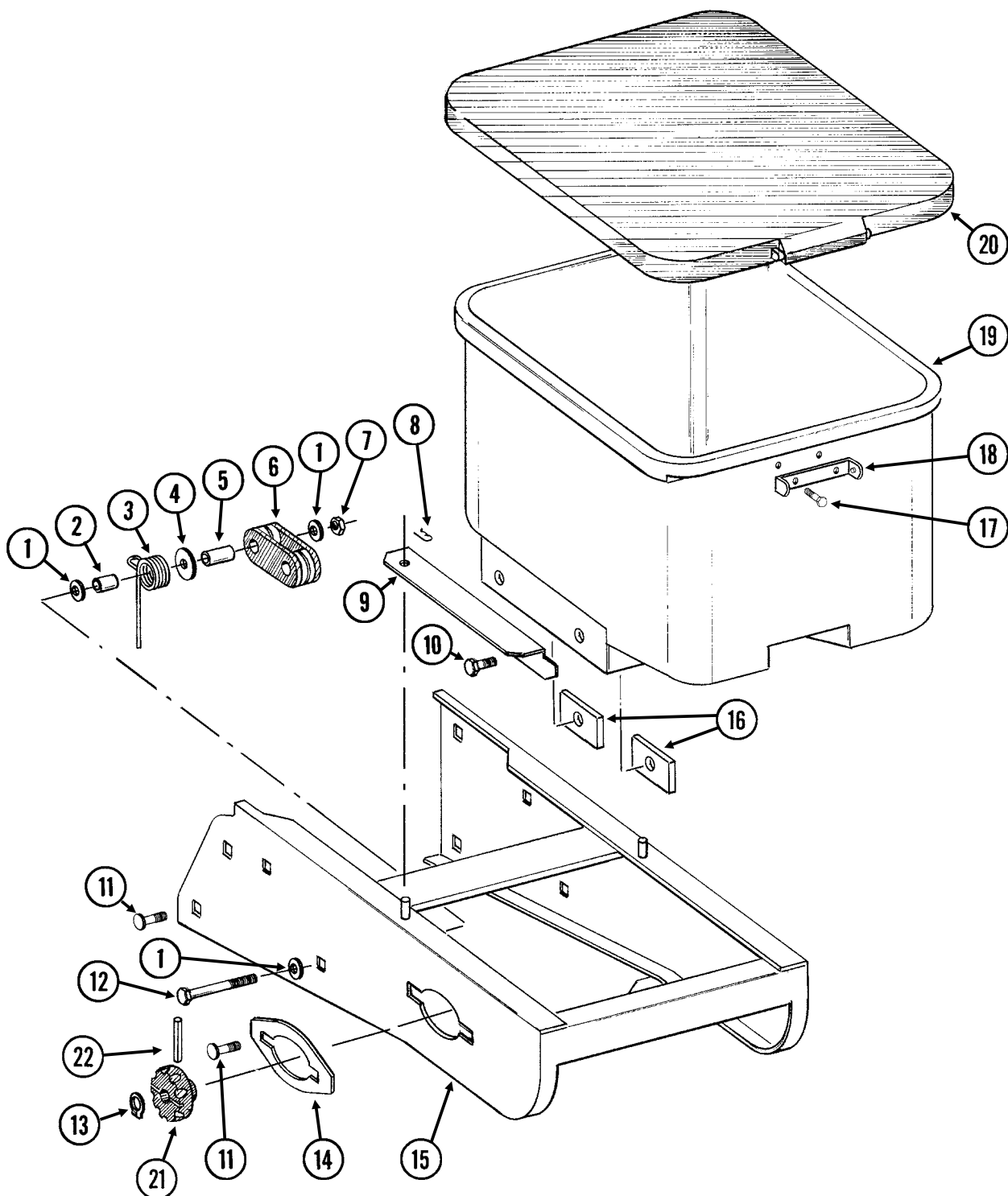

GRANULAR CHEMICAL HOPPER AND HOPPER PANEL EXTENSION

ITEM	PART NO.	QTY. (Per Row)	DESCRIPTION
1.	G10210	3	Washer, 3/8" USS
2.	GD2971-10	1	Sleeve, 9/16" Long
3.	GD11219	1	Spring
4.	G10201	1	Special Washer, 3/8" x 1 1/2" O.D.
5.	GD1026	1	Sleeve, 1 3/16" Long
6.	GD11962	1	Idler
7.	G10108	1	Lock Nut, 3/8"-16
8.	G10670	2	Hair Pin Clip, No. 3
9.	GD1059L	1	Support, L.H. (Shown)
	GD1059R	1	Support, R.H.
10.	G10002	4	Hex Head Cap Screw, 3/8"-16 x 3/4"
	G10229	4	Lock Washer, 3/8"
11.	G10312	8	Carriage Bolt, 5/16"-18 x 3/4"
	G10620	8	Serrated Flange Nut, 5/16"-18
12.	G10325	1	Hex Head Cap Screw, 3/8"-16 x 2 3/4"
13.	G10567	3	External Retaining Ring, 5/8"
14.	GD11305	1	Plate
15.	A10759	1	Hopper Panel Extension (Non-Stock Item) (Sub Wholegoods Order Code 700-01099)
16.	GD11424	4	Block
17.	G10023	2	Hex Head Cap Screw, 1/4"-20 x 3/4"
	G10621	2	Serrated Flange Nut, 1/4"-20
18.	GD1060	1	Hinge
19.	GA8371	1	Hopper
20.	GA4444	1	Lid
21.	GD11239	1	Knob
22.	G10602	1	Spring Pin, 1/4" x 1 1/2"

GRANULAR CHEMICAL METER AND METER DRIVE

RUA051/RUB028(RU91a)

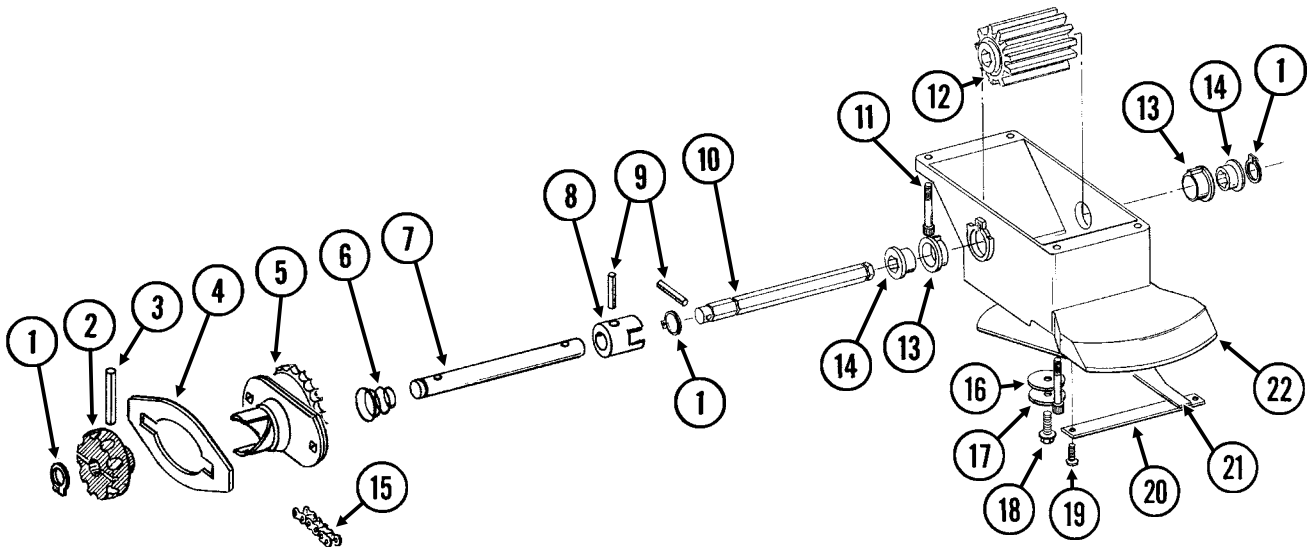

ITEM	PART NO.	QTY. (Per Row)	DESCRIPTION
1.	G10567	3	External Retaining Ring, 5/8"
2.	GD11239	1	Knob
3.	G10602	1	Spring Pin, 1/4" x 1 1/2"
4.		-	See "Granular Chemical Hopper And Hopper Panel Extension", Pages P26 And P27
5.	GA8364	1	Sprocket And Bearing, Drive Clutch, 24 Tooth
6.	GD11413	1	Spring
7.	GD11240	1	Shaft
8.	GB0278	1	Coupler
9.	G10546	2	Spring Pin, 3/16" x 1 1/4"
10.	GD11297	1	Shaft
11.	G10921	4	Hex Socket Head Cap Screw, No. 10-24 x 7/8"
	G10257	4	Lock Washer, No. 10
12.	GD7148	1	Feed Roller, Hex Bore
13.	GB0115	2	Bearing
14.	GD7258	2	Hex Bushing
15.	G3303-108	1	Chain, No. 41, 108 Pitch Including Connector Link
	GR0196	1	Connector Link, No. 41
16.	G10660	1	Wave Washer, 1/2"
17.	G10209	1	Washer, 1/4" USS
18.	G10570	1	Slotted Hex Self-Tapping Screw, 1/4"-20 x 3/4"
19.	G11073	2	Slotted Hex Self-Tapping Screw, No. 10 x 3/8"
20.	GD1061	1	Support Strap
21.	GD1063	1	Metering Gate
22.	GB0116	1	Granular Housing
A.	GA8326	-	Granular Chemical Meter Complete (Items 1, 9, 10, 12-14 And 16-22)

GRANULAR CHEMICAL BANDING OPTIONS

RUA061/RUA073(RU101mm/RU101n)

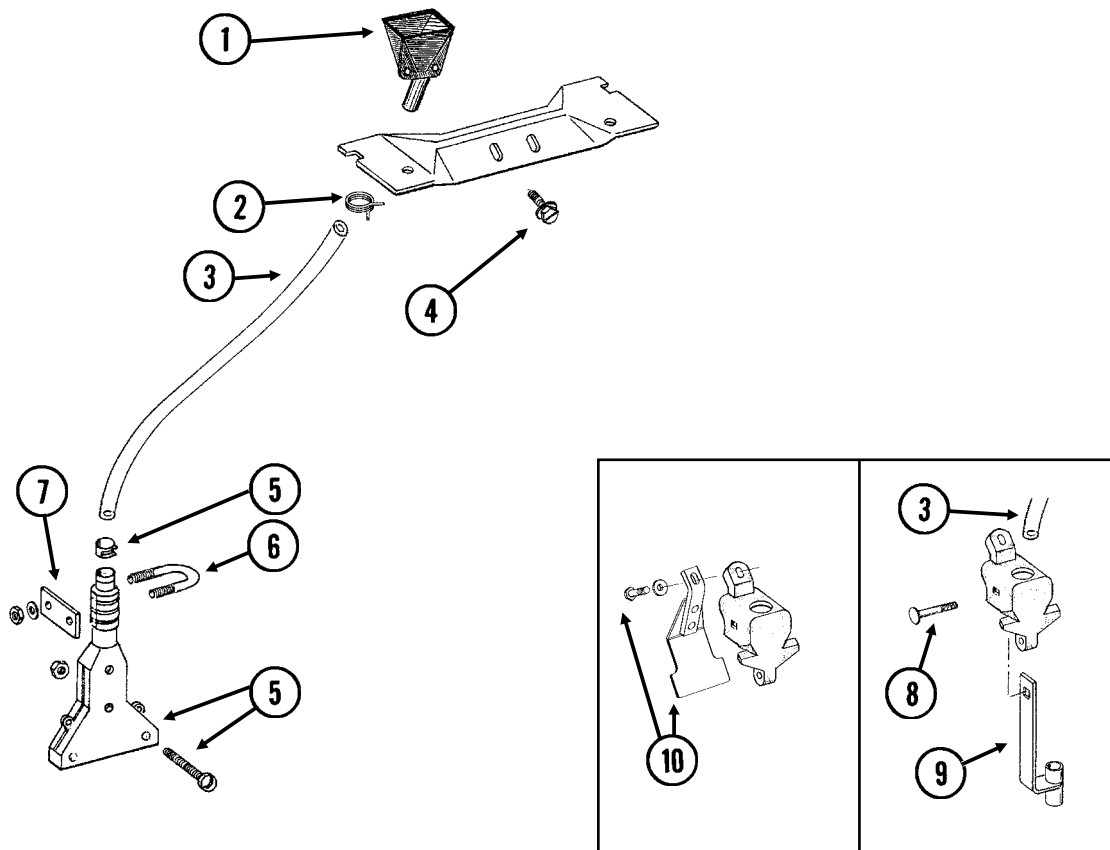

ITEM	PART NO.	QTY.	DESCRIPTION
1.	GD2423	1	Funnel
2.	G11209	1	Wire Hose Clamp, 3/4"
3.	GD2947	1	Hose, 7/16" x 28"
4.	G10523	2	Slotted Pan Head Self-Tapping Screw, No. 10 x 1/2"
5.	GA6907	1	Slope-Compensating Bander W/Hardware (4 1/2" Band Width)
	G10864	1	Uni-Clamp
	G10757	2	Pan Head Screw, No. 10-32 x 1 1/4"
	G10758	2	Hex Nut, No. 10-32
6.	GD10963	1	U-Bolt, 1 1/2" x 1 5/16" x 1/4"-20
	G10209	2	Washer, 1/4" USS
	G10110	2	Lock Nut, 1/4"-20, Grade B
7.	GD10984	1	Spacer
8.	G10315	1	Carriage Bolt, 1/2"-13 x 2 1/2" (Replaces Existing 1/2" x 2 1/4" Hardware)
9.	GA6741	1	Bracket (Straight Drop In-Furrow)
10.	G1K385	-	Bander Shield Kit W/Hardware And Instruction
	G10003	1	Hex Head Cap Screw, 3/8"-16 x 1 1/2"
	GD14659	1	Special Washer, 3/8", Hardened

ROW UNIT MOUNTED NO TILL COULTER

RUA061(RU102/RU102c)

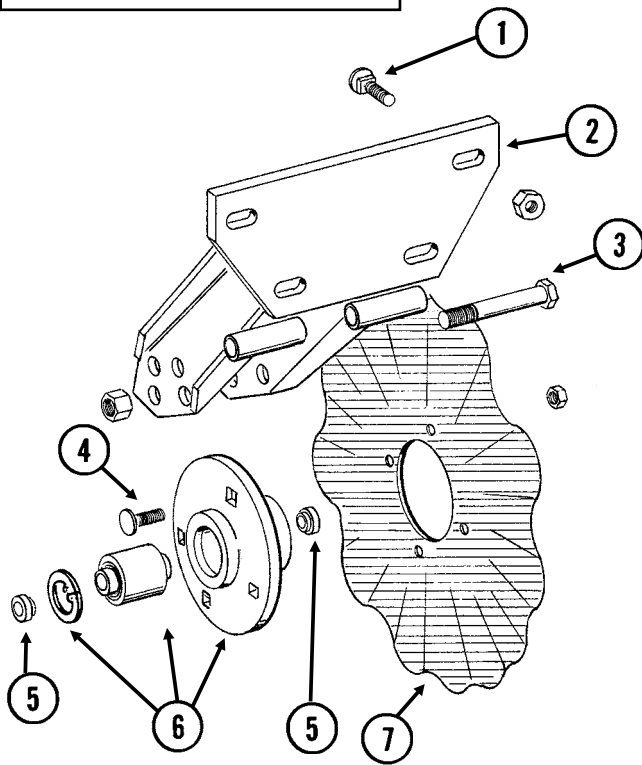
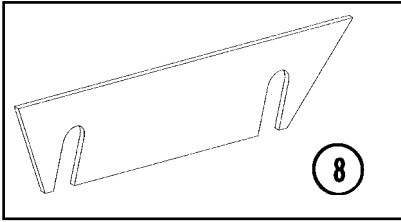

STYLE A

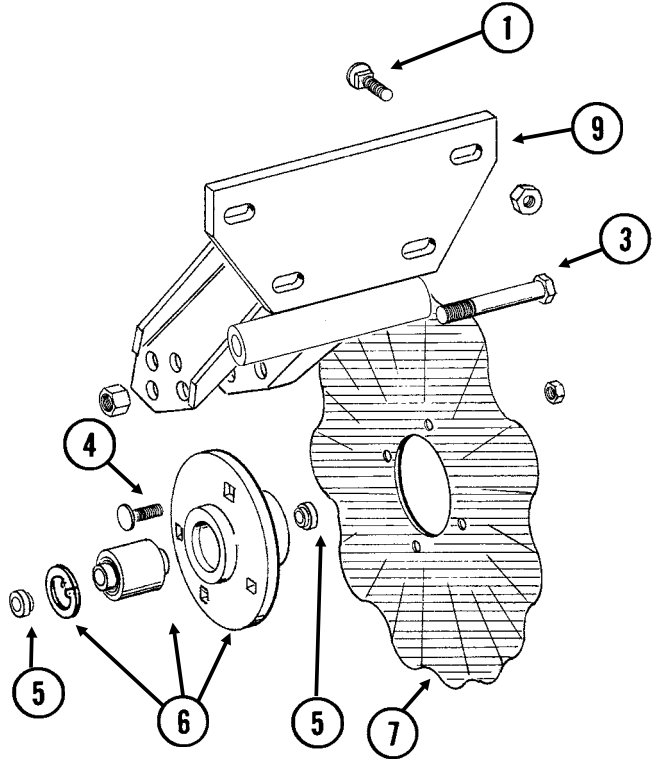

STYLE B

ROW UNIT MOUNTED NO TILL COULTER

ITEM	PART NO.	QTY. (Per Row)	DESCRIPTION
1.	G10574	4	Carriage Bolt, 1/2"-13 x 1 1/4"
	G10111	4	Lock Nut, 1/2"-13
2.	GA5625	1	Arm
3.	G10036	1	Hex Head Cap Screw, 5/8"-11 x 4"
	G10107	1	Lock Nut, 5/8"-11
4.	G10574	4	Carriage Bolt, 1/2"-13 x 1 1/4"
	G10111	4	Lock Nut, 1/2"-13
5.	GD11677	2	Adapter
6.	GA8641	1	Hub W/Bearing And Retaining Ring
	GA8603	-	Bearing, Double Row
	GD11652	-	Retaining Ring, 2 7/16"
7.	GD7803	-	Disc Blade, Fluted, 1", 8 Flutes (Shown)
	GD7804	-	Disc Blade, Bubbled, 1"
	GD9254	-	Disc Blade, Fluted, 3/4", 13 Flutes
8.	GD14398	-	Spacer
9.	GA11520	1	Arm (Style B)

ROW UNIT MOUNTED DISC FURROWER

RUA059/RUA058(RU99/RU98g)

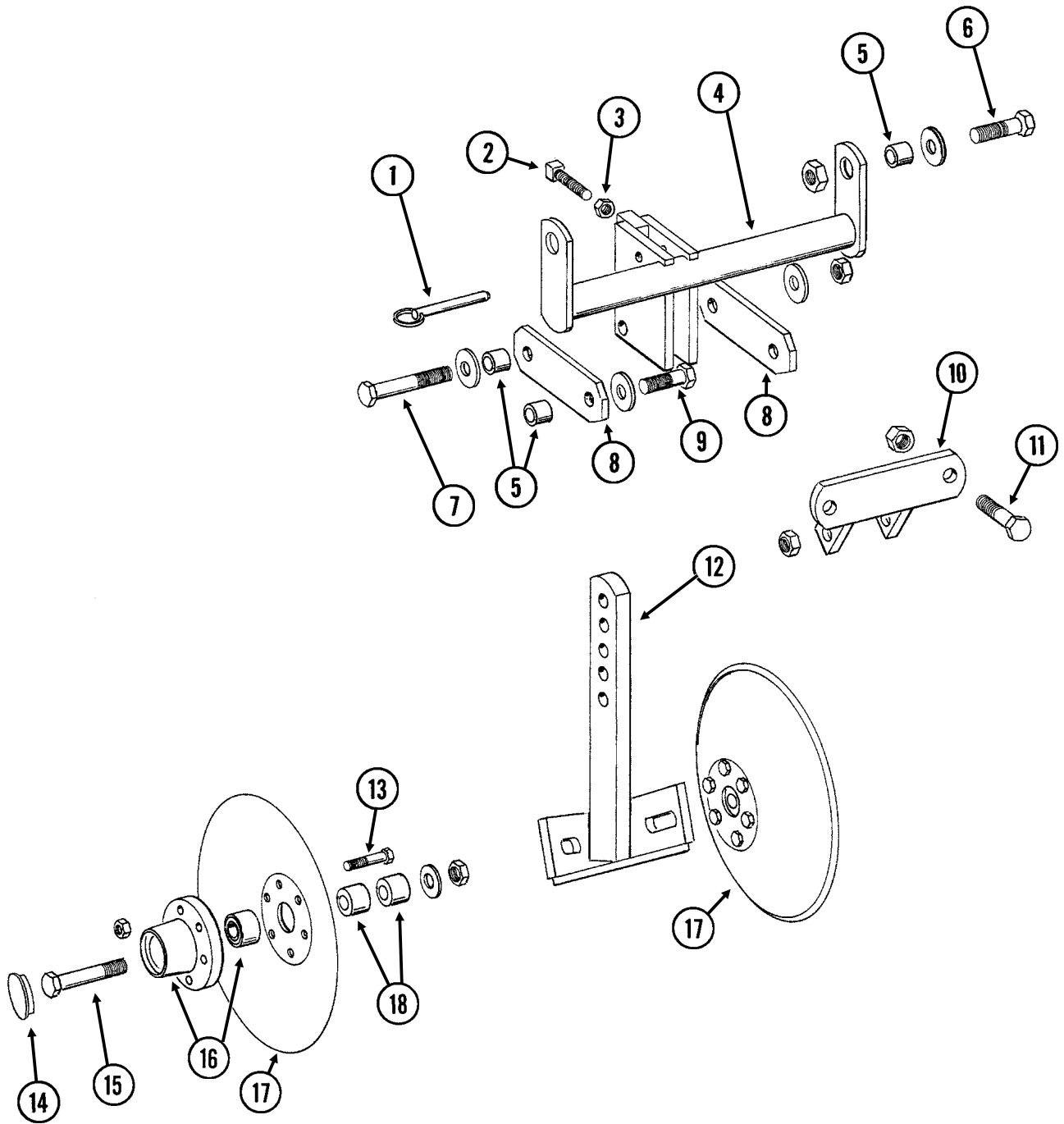

ROW UNIT MOUNTED DISC FURROWER

ITEM	PART NO.	QTY. (Per Row)	DESCRIPTION
1.	G10536	1	Detent Pin, 1/2" x 2 1/2" Grip
2.	G10597	1	Square Head Set Screw, 5/8"-11 x 2 1/4"
3.	G10503	1	Hex Jam Nut, 5/8"-11, Grade 2
4.	GA5719	1	Mounting Bracket
5.	GD7889	6	Bushing, 1" O.D. x 9/16" I.D. x 7/16" Long
6.	G10039	2	Hex Head Cap Screw, 1/2"-13 x 1 3/4"
	GD14674	2	Special Washer, 1/2", Hardened
	G10111	2	Lock Nut, 1/2"-13
7.	G10585	1	Hex Head Cap Screw, 1/2"-13 x 3 1/4"
	G10216	2	Washer, 1/2" USS
	G10111	1	Lock Nut, 1/2"-13
8.	GD7890	2	Link
9.	G10017	2	Hex Head Cap Screw, 1/2"-13 x 1 1/2"
	G10216	2	Washer, 1/2" USS
	G10111	2	Lock Nut, 1/2"-13
10.	GA5715	1	Anchor
11.	G10017	2	Hex Head Cap Screw, 1/2"-13 x 1 1/2"
	G10111	2	Lock Nut, 1/2"-13
12.	GA5718	1	Support Arm
13.	G10572	6	Truss Head Slotted Machine Screw, 5/16"-18 x 7/8"
	G10106	6	Hex Nut, 5/16"-18
14.	GD1132	2	Dust Cap
15.	G10318	2	Hex Head Cap Screw, 5/8"-11 x 4 1/2"
	GD7805	2	Special Washer, 5/8", Hardened
	G10107	2	Lock Nut, 5/8"-11
16.	GA5654	2	Hub W/Bearings
	GA2014	-	Bearing
17.	GD7823	-	Disc Blade, Solid, 12" (Shown)
	GD8307	-	Disc Blade, Notched, 12"
18.	GD7817-01	2	Spacer, 1 1/16" I.D. x 3/4" Long
	GD7817-04	2	Spacer, 1 1/16" I.D. x 1/2" Long

ROW UNIT MOUNTED RESIDUE WHEEL

(RU103dd/RU103d)

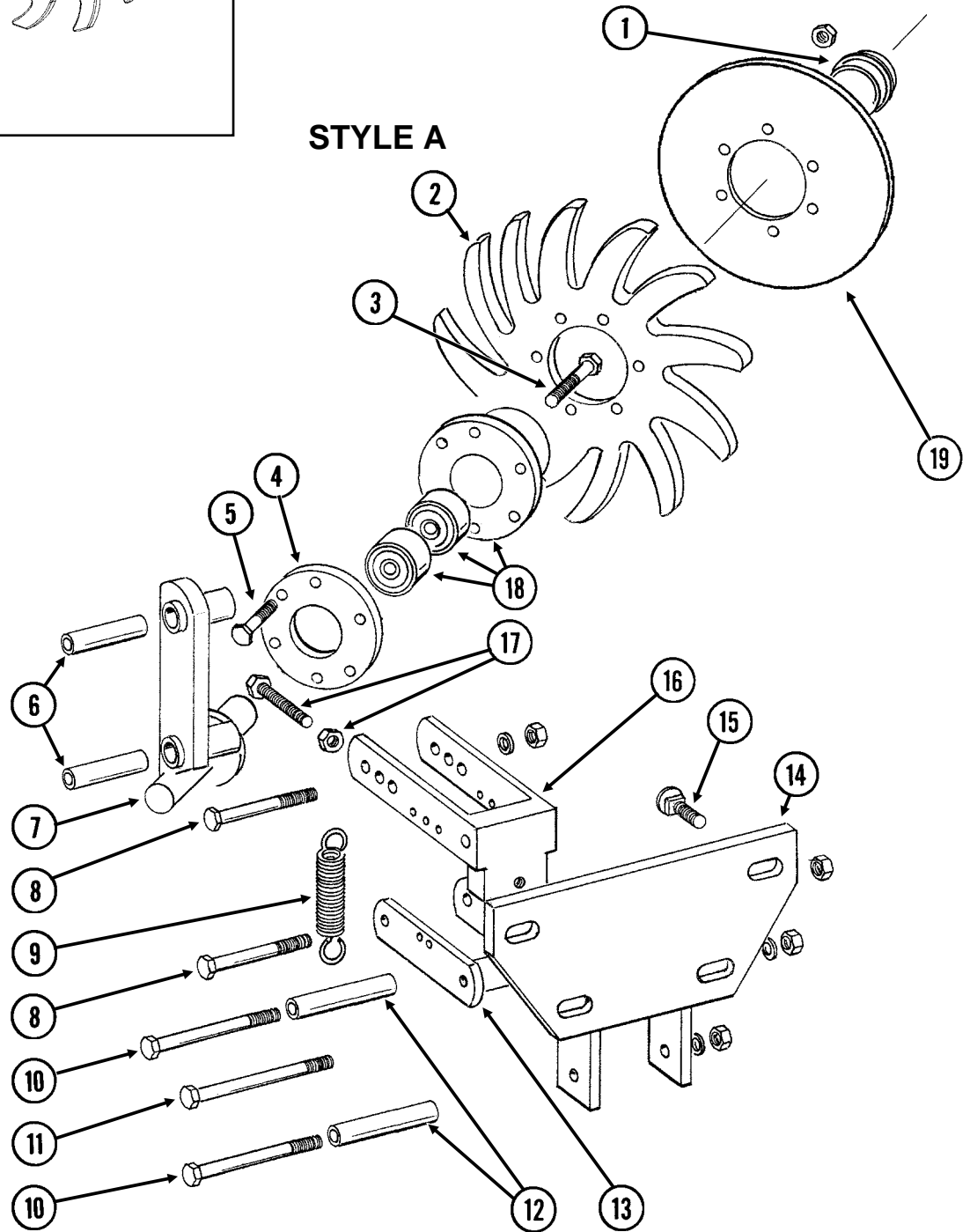
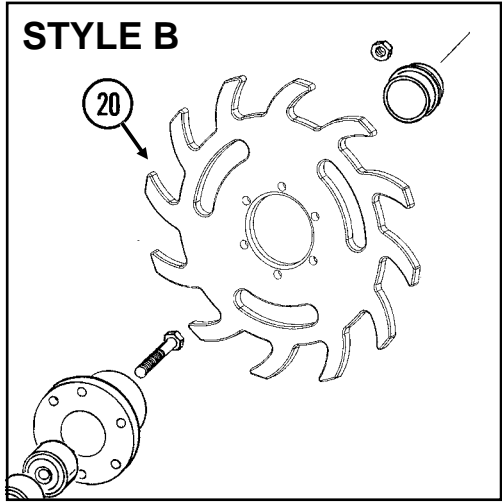

ROW UNIT MOUNTED RESIDUE WHEEL

ITEM	PART NO.	QTY. (Per Row)	DESCRIPTION
1.	GD1132	1	Dust Cap
2.	GD10552	1	Wheel, 12 Tine, 3/8" x 12"
3.	G10006	1	Hex Head Cap Screw, 5/8"-11 x 2 1/4"
4.	GD9724	1	Backing Plate
5.	G10133	6	Hex Head Cap Screw, 5/16"-18 x 1 1/2"
	G10109	6	Lock Nut, 5/16"-18, Grade 8
6.	GD9720	2	Spacer, 1/2" x 2 3/16" Long
7.	GA6838	1	Wheel Mount
8.	G10033	2	Hex Head Cap Screw, 1/2"-13 x 3 1/2"
	G10228	2	Lock Washer, 1/2"
	G10102	2	Hex Nut, 1/2"-13
9.	GD5857	2	Spring
10.	G10045	2	Hex Head Cap Screw, 1/2"-13 x 4 1/2"
	G10228	2	Lock Washer, 1/2"
	G10102	2	Hex Nut, 1/2"-13
11.	G10348	1	Hex Head Cap Screw, 1/2"-13 x 5" (Lockup Bolt)
	G10111	1	Lock Nut, 1/2"-13
12.	GD9715	2	Spacer, 1/2" x 3" Long
13.	GA6834	1	Lower Link
14.	GA6832	1	Mount
15.	G10574	4	Carriage Bolt, 1/2"-13 x 1 1/4"
	G10111	4	Lock Nut, 1/2"-13
16.	GA6833	1	Upper Link
17.	G10371	1	Hex Head Cap Screw, 1/2"-13 x 3", Full Thread
	G10501	1	Hex Jam Nut, 1/2"-13, Grade 2
18.	GA5654	1	Hub W/Bearings
	GA2014	-	Bearing
19.	GD12534	-	Cover
20.	GB0387	-	Wheel, 12 Tine, 3/8" x 12"
A.	GA7446	-	Wheel Assembly, 12 Tine (Items 2, 4, 5 And 18)
B.	GA12236	-	Wheel Assembly, 12 Tine (Items 4, 5, 18 And 20)

COULTER MOUNTED RESIDUE WHEELS

RU153/(RU104uu)

STYLE A - Used With Style A Row Unit Mounted No Till Coulter

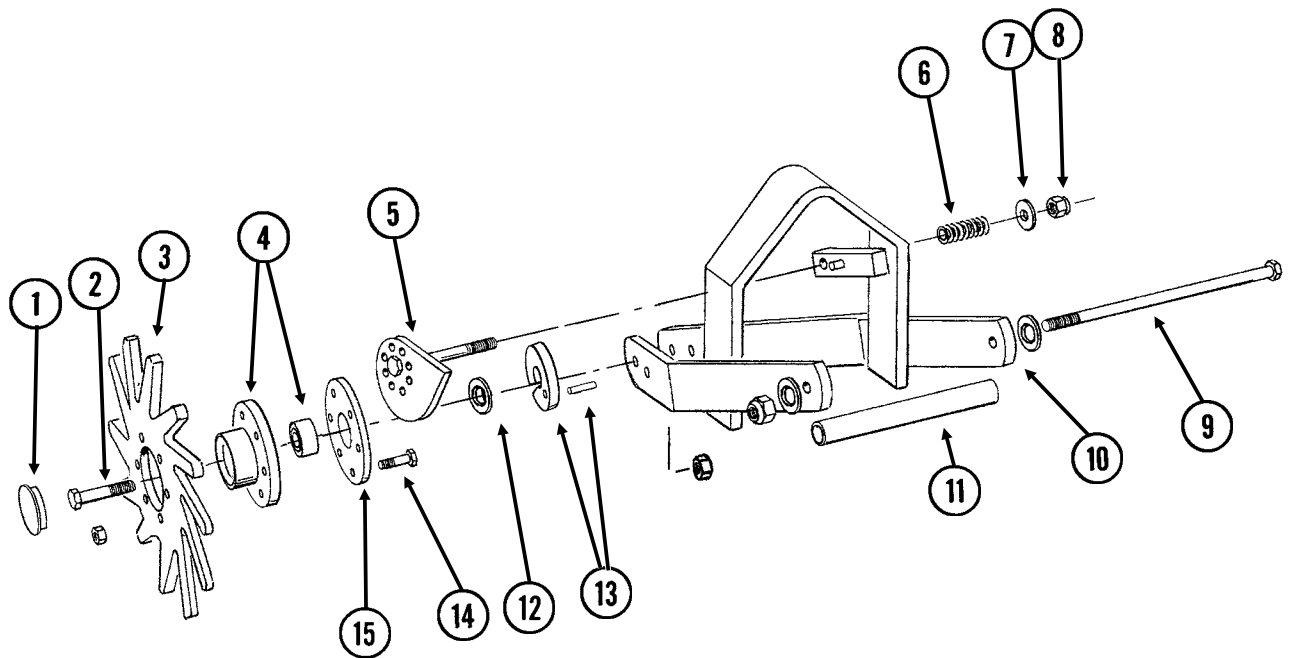

STYLE B - Used With Style B Row Unit Mounted No Till Coulter

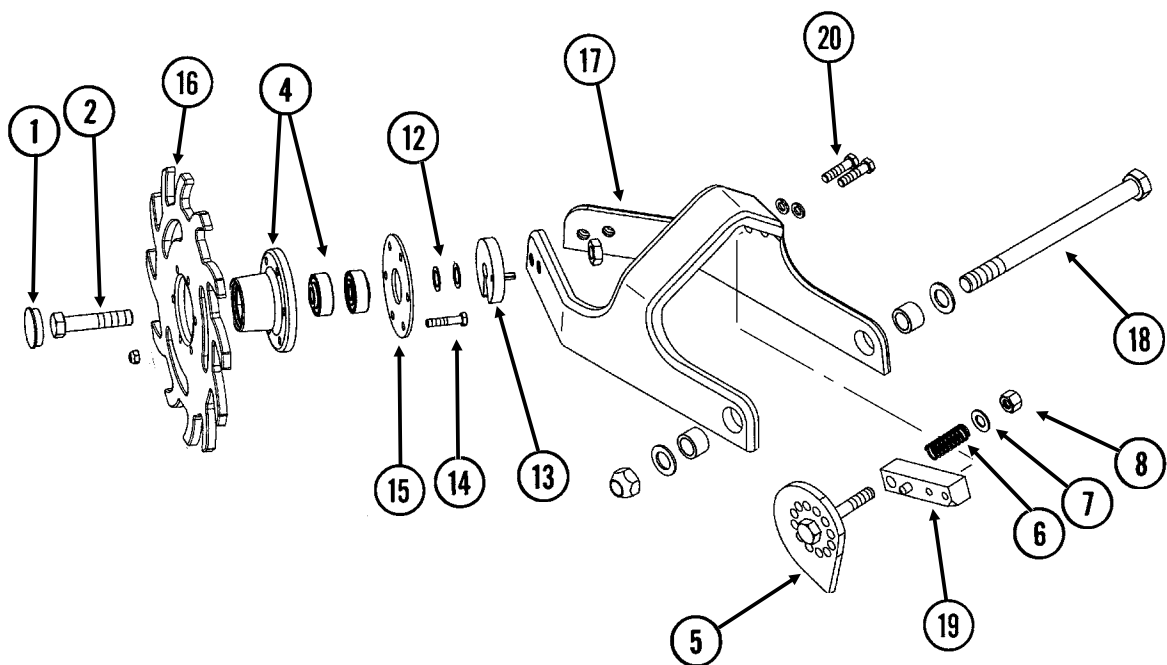

COULTER MOUNTED RESIDUE WHEELS

ITEM	PART NO.	QTY. (Per Row)	DESCRIPTION
1.	GD1132	2	Dust Cap
2.	G10010	2	Hex Head Cap Screw, 5/8"-11 x 3"
	G10503	2	Hex Jam Nut, 5/8"-11, Grade 2
3.	GD10552	2	Wheel, 12 Tine, 3/8" x 12"
4.	GA5654	2	Hub W/Bearings
	GA2014	-	Bearing
5.	GA7412	1	Cam
6.	GD10519	1	Spring
7.	G10206	1	Washer, 1/2" SAE
8.	G10974	1	Lock Nut W/Nylon Insert, 1/2"-13
9.	G11098	1	Hex Head Cap Screw, 1/2"-13 x 9 1/2", Grade 8
	GD14674	2	Special Washer, 1/2", Hardened
	G10974	1	Lock Nut W/Nylon Insert, 1/2"-13
10.	GA7271	1	Mount
11.	GD10526	1	Sleeve, 7 1/2"
12.	G10213	2-4	Machine Bushing, 5/8" (.030" Thick)
13.	GA8760	2	Weed Guard W/Spring Pin
	G10765	-	Spring Pin, 1/4" x 1"
14.	G10133	12	Hex Head Cap Screw, 5/16"-18 x 1 1/2"
	G10109	12	Lock Nut, 5/16"-18, Grade 8
15.	GD9724	2	Backing Plate
16.	GB0387	2	Wheel, 12 Tine, 3/8" x 12"
17.	GB0401	1	Mount
18.	G11236	1	Hex Head Cap Screw, 3/4"-10 x 10 1/2"
	GB0383	2	Bushing, 1 1/8" O.D. x 25/32" I.D. x 3/4" Long
	G10194	2	Washer, 3/4" SAE
	G11228	1	Lock Nut, 3/4"-10
19.	GA12256	1	Locking Pin
20.	G10003	2	Hex Head Cap Screw, 3/8"-16 x 1 1/2"
	G10229	2	Lock Washer, 3/8"
A.	GA7446	-	Wheel Assembly, 12 Tine, R.H. (Items 3, 4, 14 And 15) (Shown)
	GA7445	-	Wheel Assembly, 12 Tine, L.H. (Items 3, 4, 14 And 15)
B.	GA12236	-	Wheel Assembly, 12 Tine, R.H. (Items 4, 14, 15 And 16) (Shown)
	GA12235	-	Wheel Assembly, 12 Tine, L.H. (Items 4, 14, 15 And 16)
C.	G1K467	-	Residue Wheel Mount Kit (Items 17-20)

FRAME MOUNTED COULTER W/RESIDUE WHEELS

(RU135c/RU135g/RU153b/RU135hh)

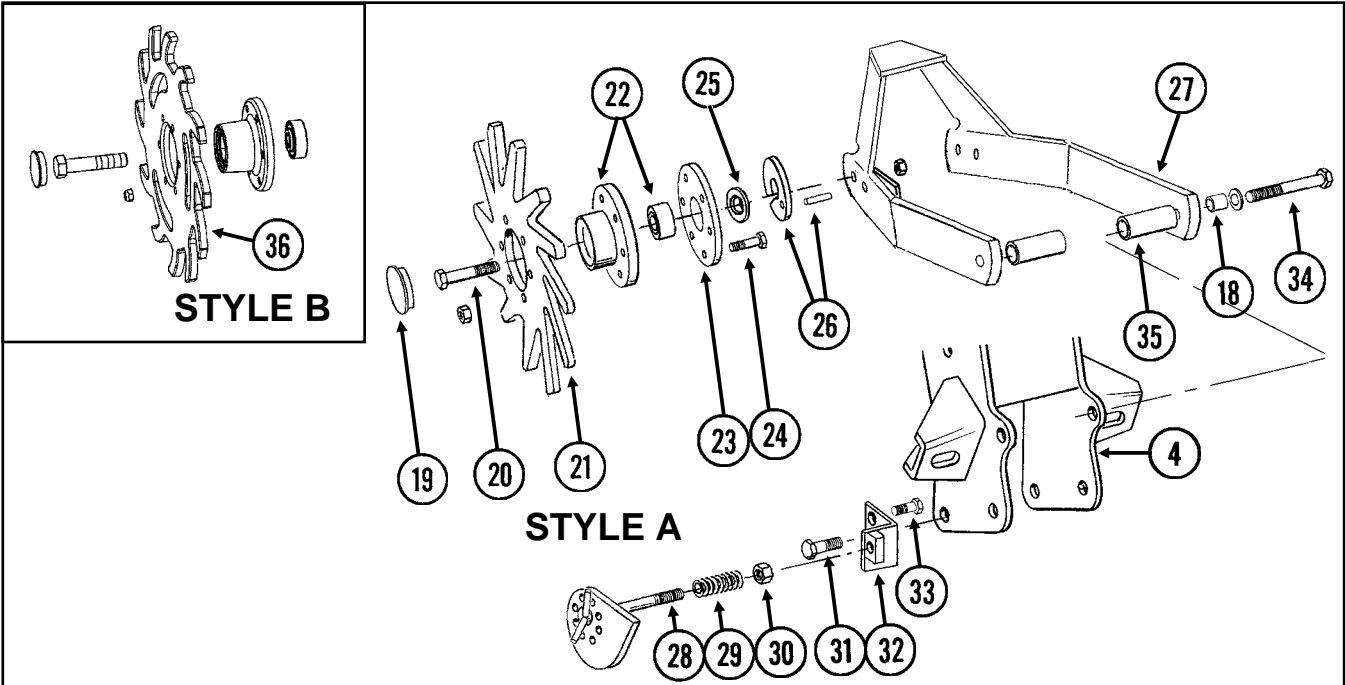
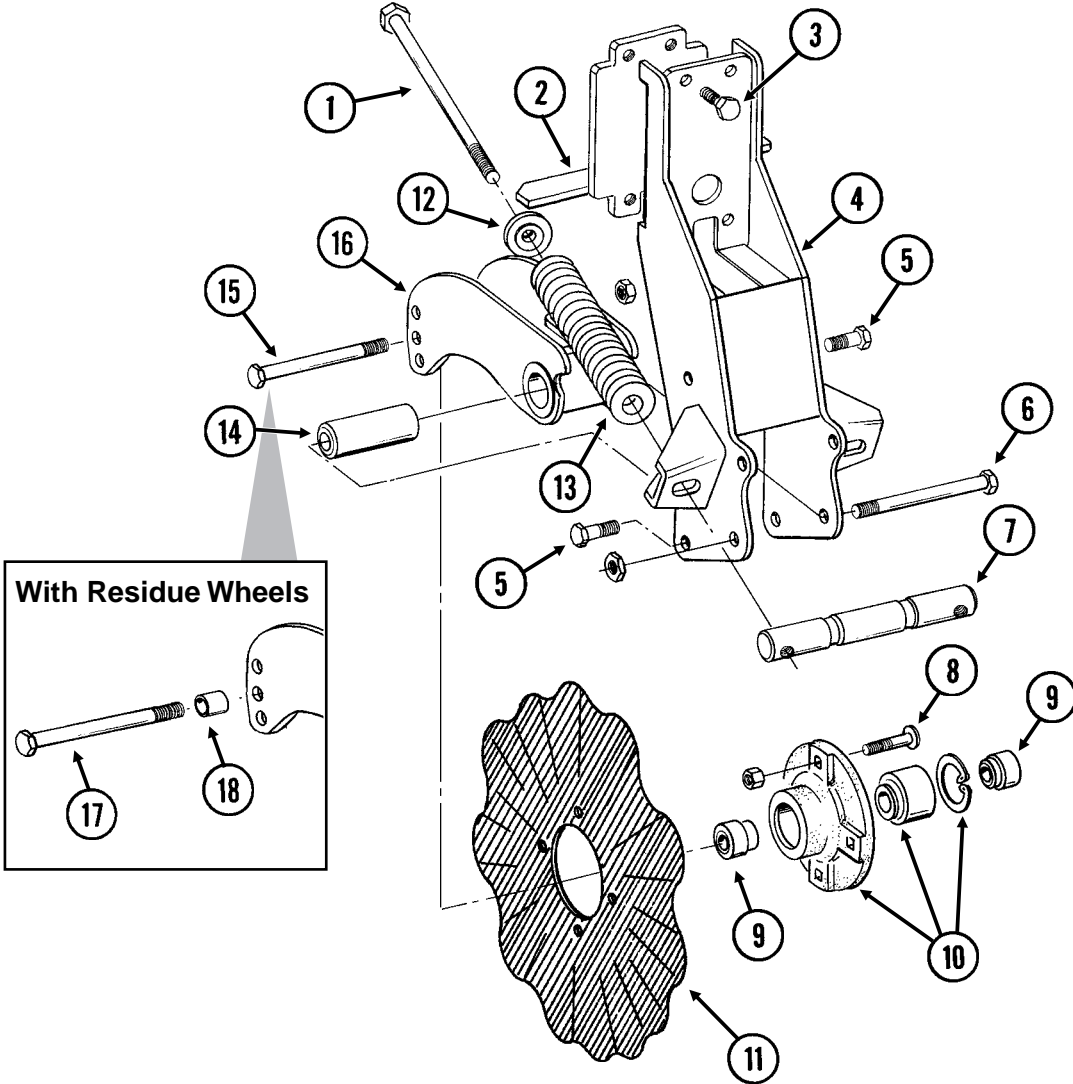

FRAME MOUNTED COULTER W/RESIDUE WHEELS

ITEM	PART NO.	QTY. (Per Row)	DESCRIPTION
1.	G11010	2	Hex Head Cap Screw, 3/4"-10 x 12"
2.	GA9844	1	Plate W/Angle
3.	G10039	4	Hex Head Cap Screw, 1/2"-13 x 1 3/4"
4.	GA9131	1	Coulter Frame
5.	G10007	4	Hex Head Cap Screw, 5/8"-11 x 1 1/2"
	G10107	4	Lock Nut, 5/8"-11
6.	G10400	1	Hex Head Cap Screw, 3/4"-10 x 6 1/2"
	G10112	1	Lock Nut, 3/4"-10
7.	GD12826	1	Spring Anchor Bar
8.	G10574	4	Carriage Bolt, 1/2"-13 x 1 1/4"
	G10111	4	Lock Nut, 1/2"-13
9.	GD12827	2	Adapter
10.	GA8641	1	Hub W/Bearing And Retaining Ring
	GA8603	1	Bearing, Double Row
	GD11652	1	Retaining Ring, 2 7/16"
11.	GD7803	1	Disc Blade, Fluted, 1", 8 Flutes (Shown)
	GD7804	-	Disc Blade, Bubbled, 1"
	GD9254	-	Disc Blade, Fluted, 3/4", 13 Flutes
12.	GB0213	2	Spring Seat
13.	GD12817	2	Compression Spring
14.	GD12829	1	Sleeve
15.	G10046	1	Hex Head Cap Screw, 5/8"-11 x 5"
	G10107	1	Lock Nut, 5/8"-11
16.	GA9845	1	Coulter Arm W/Grease Fitting
	G10643	-	Grease Fitting, 45°, 1/4"-28
17.	G10011	1	Hex Head Cap Screw, 5/8"-11 x 5 1/2"
	G10107	1	Lock Nut, 5/8"-11
18.	GB0218	3	Bushing, 2 1/32" I.D. x 7/8" O.D. x 1 9/32" Long
19.	GD1132	2	Dust Cap
20.	G10010	2	Hex Head Cap Screw, 5/8"-11 x 3"
	G10503	2	Hex Jam Nut, 5/8"-11, Grade 2
21.	GD10552	2	Wheel, 12 Tine, 3/8" x 12"
22.	GA5654	2	Hub W/Bearings
	GA2014	-	Bearing
23.	GD9724	2	Backing Plate
24.	G10133	12	Hex Head Cap Screw, 5/16"-18 x 1 1/2"
	G10109	12	Lock Nut, 5/16"-18, Grade 8
25.	G10213	2	Machine Bushing, 5/8" (.030" Thick)
26.	GA9862	2	Weed Guard W/Spring Pin
	G10765	-	Spring Pin, 1/4" x 1"
27.	GA9865	1	Mount
28.	GA9861	1	Cam
29.	GD10519	1	Spring
30.	G10974	1	Lock Nut W/Nylon Insert, 1/2"-13
31.	G10005	1	Hex Head Cap Screw, 5/8"-11 x 1 3/4"
	G10107	4	Lock Nut, 5/8"-11
32.	GA9864	1	Support
33.	G10014	1	Hex Head Cap Screw, 1/2"-13 x 1"
	G10102	1	Hex Nut, 1/2"-13
34.	G10011	2	Hex Head Cap Screw, 5/8"-11 x 5 1/2"
	G10205	2	Washer, 5/8" SAE
	G10730	2	Lock Nut W/Nylon Insert, 5/8"-11
35.	GD14170	2	Sleeve, 3"
A.	GA7446	-	Wheel Assembly, 12 Tine, R.H. (Items 21-24) (Shown)
	GA7445	-	Wheel Assembly, 12 Tine, L.H. (Items 21-24)
B.	GA12236	-	Wheel Assembly, 12 Tine, R.H. (Items 22, 23, 24 And 36) (Shown)
	GA12235	-	Wheel Assembly, 12 Tine, L.H. (Items 22, 23, 24 And 36)

INTERPLANT® PUSH ROW UNIT

(A12177c/RU150a/A11969)

NOTE: Push row units use the same seed tube, row unit depth adjustment components, quick adjustable down force springs, 15" opener disc blades, gauge wheels, closing wheels, meter drive and seed hopper as the pull row unit. See those pages for common parts.

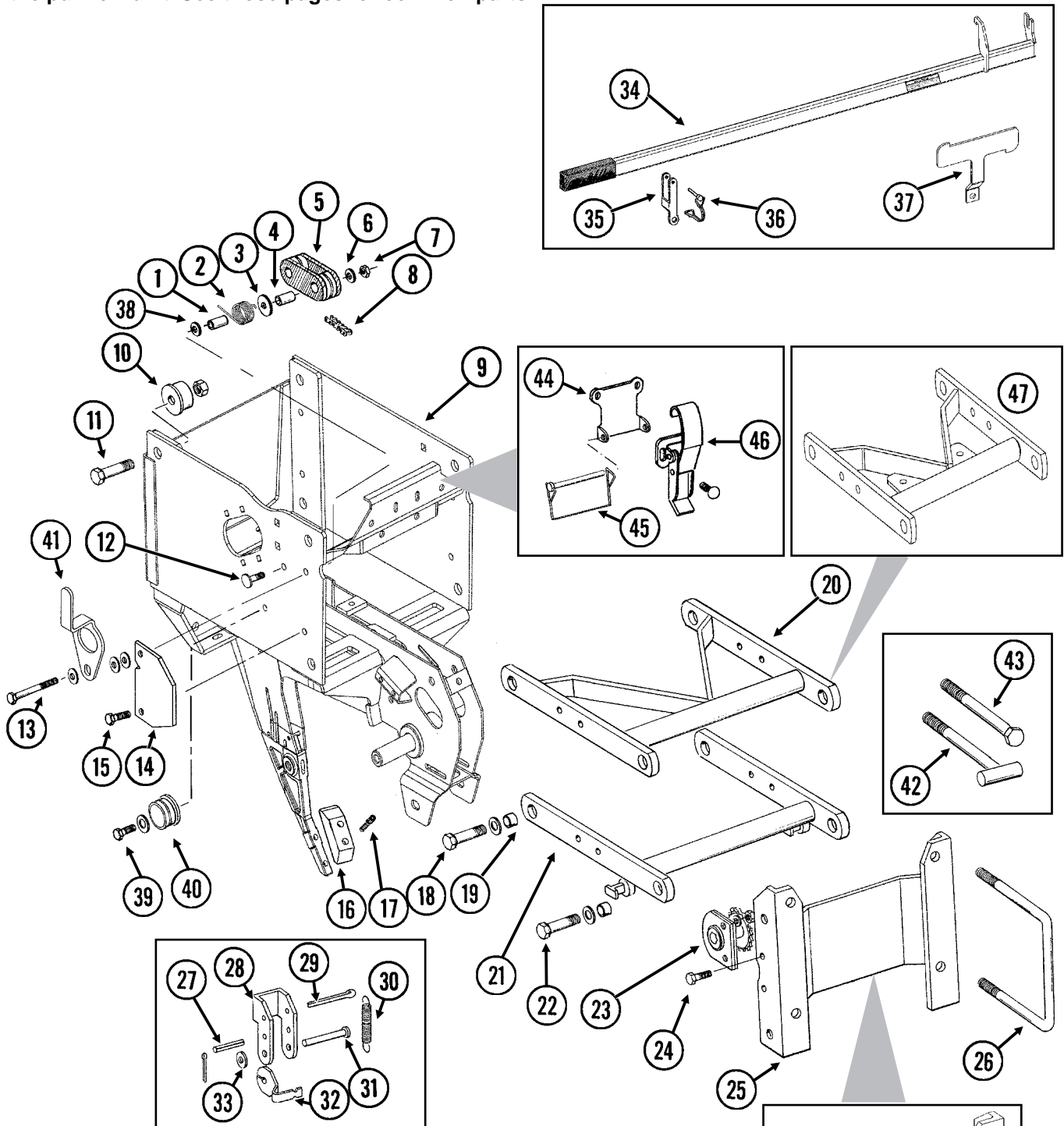

ITEM	PART NO.	QTY. (Per Row)	DESCRIPTION
1.	GD1026	1	Sleeve, 1 3/16" Long
2.	GD11218	1	Spring
3.	G10201	1	Special Washer, 3/8" x 1 1/2" O.D.
4.	GD8893-01	1	Sleeve, 1 3/8" Long
5.	GD11962	1	Idler
6.	G10210	1	Washer, 3/8" USS

INTERPLANT® PUSH ROW UNIT

ITEM	PART NO.	QTY. (Per Row)	DESCRIPTION
7.	G10108	1	Lock Nut, 3/8"-16
8.	G3303-100	1	Chain, No. 41, 100 Pitch Including Connector Link And Offset Link
	GR0196	1	Connector Link, No. 41
	GR0202	-	Offset Link, No. 41
9.	GA10161	-	Push Row Unit Shank
10.	GB0314	2	Hopper Mount
11.	G10751	2	Hex Head Cap Screw, 5/8"-18 x 1 3/4"
	G10412	2	Lock Nut, 5/8"-18
12.	G10599	1	Carriage Bolt, 3/8"-16 x 1 1/4"
	G10101	1	Hex Nut, 3/8"-16
	G10108	1	Lock Nut, 3/8"-16
13.	G10753	1	Hex Head Cap Screw, 3/8"-16 x 4 1/2"
	G10203	3	Washer, 3/8" SAE
14.	GD10867	2	Stop
15.	G10004	3	Hex Head Cap Screw, 3/8"-16 x 1 1/4"
	G10108	3	Lock Nut, 3/8"-16
16.	GB0301	1	Seed Tube Guard/Inner Scraper
17.	G10912	2	Hex Socket Head Cap Screw, 5/16"-18 x 1", Grade 8
18.	G10751	4	Hex Head Cap Screw, 5/8"-18 x 1 3/4"
	GD7805	4	Special Washer, 5/8", Hardened
	G10412	4	Lock Nut, 5/8"-18
19.	GB0218	8	Bushing, 2 1/32" I.D. x 7/8" O.D. x 1 9/32" Long
20.	GA8930	-	Upper Arm
21.	GA5787	1	Lower Arm
22.	G10732	4	Hex Head Cap Screw, 5/8"-18 x 2"
	GD7805	4	Special Washer, 5/8", Hardened
	G10412	4	Lock Nut, 5/8"-18
23.	GA1720	1	Bearing/Sprocket, 7/8" Hex Bore
24.	G10004	2	Hex Head Cap Screw, 3/8"-16 x 1 1/4"
	G10229	2	Lock Washer, 3/8"
	G10101	2	Hex Nut, 3/8"-16
25.	GA5786	1	Mounting Plate
26.	GD1113	2	U-Bolt, 5" x 7" x 5/8"-11
	G10230	4	Lock Washer, 5/8"
	G10104	4	Hex Nut, 5/8"-11
27.	G10718	2	Spring Pin, 5/16" x 1 1/8"
28.	GD11264	2	Lockup
29.	G10463	2	Cotter Pin, 1/4" x 1 1/2"
30.	GD11447	2	Spring
31.	G10284	2	Clevis Pin, 1/2" x 1 1/2"
	G10456	2	Cotter Pin, 1/8" x 3/4"
32.	GD11263	2	Spring Tab
33.	G10216	2	Washer, 1/2" USS
34.	GA12117	1	Lift Lever W/Boot
	GD11649	-	Boot
35.	GD11659	1	Bracket
36.	GD9695	1	Wire Lock Pin, 1/4" x 1 3/4"
37.	GD17169	1	Mount
38.	G10203	1	Washer, 3/8" SAE
39.	G10001	1	Hex Head Cap Screw, 3/8"-16 x 1"
	G10210	-	Washer, 3/8" USS
	G10108	1	Lock Nut, 3/8"-16
40.	GD17052	1	Vacuum Plug
41.	GD17014	1	Hose Guide
42.	GA9105	-	T-Bolt, 5/8"-11 x 6"
	G10230	-	Lock Washer, 5/8"
	G10104	-	Hex Nut, 5/8"-11
43.	G10830	-	Hex Head Cap Screw, 5/8"-11 x 7 1/2"
	G10230	-	Lock Washer, 5/8"
	G10104	-	Hex Nut, 5/8"-11
44.	GD13110	-	Retainer (SDS Only)
45.	GD10705	-	Locking Clip Pin, 1/4" x 2 1/2" (SDS Only)
46.	GA2007	-	Hopper Hold Down Latch
47.	A11969	-	Upper Arm
48.	A11971	-	Mounting Plate

DIGITAL VACUUM GAUGE, ANALOG VACUUM GAUGE AND VACUUM FAN ASSEMBLY

(A11154/A11156/GR1736/A10765a/A11158/A11699/A7856/A11155/A8329/METR75)

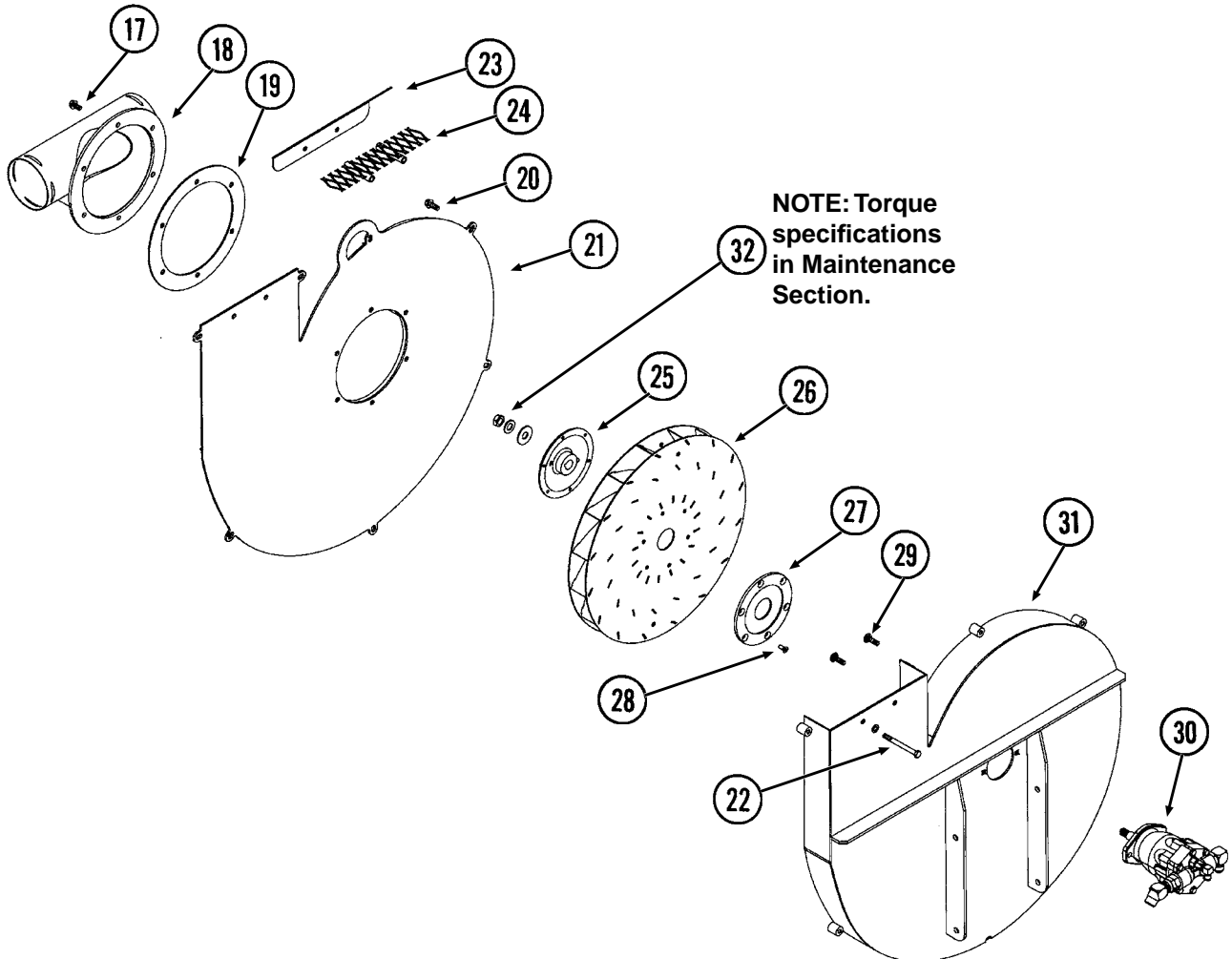
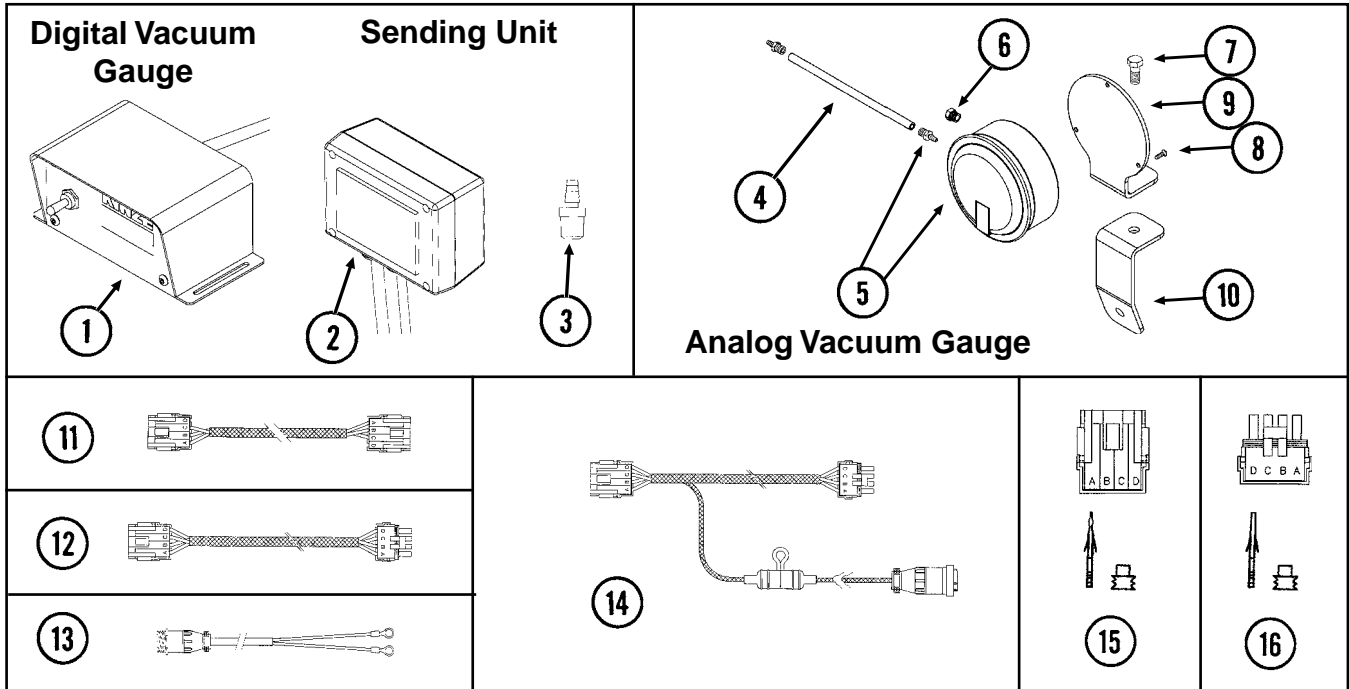

DIGITAL VACUUM GAUGE, ANALOG VACUUM GAUGE AND VACUUM FAN ASSEMBLY

ITEM	PART NO.	QTY.	DESCRIPTION
1.	GA11154	1	Digital Vacuum Gauge W/4-Pin Connector
2.	GA11156	1	Sending Unit W/1/4" Tubing And Harness
	GD16324-01	-	Tubing, 1/4" x 45"
	GA9964	-	Strain Relief
3.	GR1736	1	Hose Barb, 1/8" Barb To 1/8" Male NPT
4.	GD15849-02	1	Clear Plastic Tubing, 5/16" O.D. x 120"
5.	GA10765	1	Analog Vacuum Gauge W/Hose Barb
	GR1777	-	Hose Barb, 1/8" Male NPT To 3/16" Barb
6.	GA10799	1	Breather, 1/8" Male NPT
7.	G10001	1	Hex Head Cap Screw, 3/8"-16 x 1"
	G10108	1	Lock Nut, 3/8"-16
8.	G11215	3	Hex Socket Head Cap Screw, No. 6-32 x 3/8", Grade 8
9.	GD15804	1	Mount
10.	GD15945	1	Support
11.	GA11159	1	Harness, 550", 12 Row 30"
	GA11160	-	Harness, 670", 16 Row 30"
12.	GA11699	-	Extension Harness, 180"
13.	GA7856	-	Power Lead Adapter
14.	GA11155	1	Harness W/Fuse Holder And Fuse, 132"
	GD14258	-	Fuse Holder
	GD14660	-	Fuse, 2 Amp Delay Action
	G1K268	-	Console Cable Connector Kit, Includes: (1) 3-Pin Connector, (1) Cable Clamp, (1) Lock Ring, (3) Female Terminal Pins
15.	GA8328	-	4-Pin Connector W/Female Housing, 4 Seals And 4 Pin Contacts
16.	GA8329	-	4-Pin Connector W/Male Housing, 4 Seals And 4 Socket Contacts
17.	G11124	6	Whiz Lock Bolt, 3/8"-16 x 1"
18.	GA12151	1	Manifold
19.	GD17268	1	Gasket, 9" I.D. x 12" O.D.
20.	G11124	7	Whiz Lock Bolt, 3/8"-18 x 1"
21.	GA10752	1	Cover
22.	G10063	2	Hex Head Cap Screw, 3/8"-16 x 4"
	G10753	2	Hex Head Cap Screw, 3/8"-16 x 4 1/2"
	G10203	2	Washer, 3/8" SAE
	G10229	2	Lock Washer, 3/8"
	G10101	2	Hex Nut, 3/8"-16
23.	GD15863	1	Discharge Deflector
24.	GA11987	1	Screen
25.	GD15790	1	Hub
26.	GA10635	1	Impeller
27.	GD15789	1	Backing Plate
28.	G11133	6	Hex Socket Head Cap Screw, 5/16"-18 x 3/4", Grade 8
29.	G10599	2	Carriage Bolt, 3/8"-16 x 1 1/4"
	G10108	2	Lock Nut, 3/8"-16
30.		-	See "Vacuum Fan Hydraulic Motor Assembly", Page P44
31.	GA10148	1	Shroud
32.	G10205	1	Washer, 5/8" SAE
	G10499	1	Hex Jam Nut, 5/8"-18, Grade 2
A.	GA11339	-	Vacuum Fan Assembly (Items 20-32)

VACUUM FAN HYDRAULIC MOTOR ASSEMBLY

(A11338)

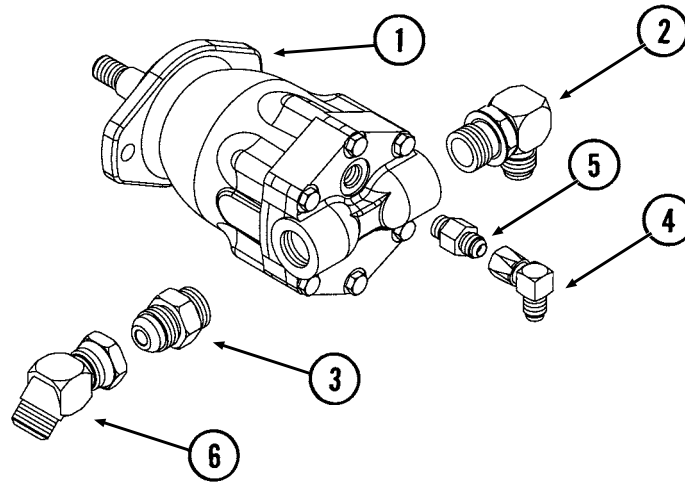

ITEM	PART NO.	QTY.	DESCRIPTION
1.	GA10149 GR1734	1 -	Hydraulic Motor Seal Kit
2.	G6801-10-12 GR1467	1 -	Elbow W/O-Ring, 90°, 7/8"-14 Male JIC To 1 1/16"-12 O-Ring O-Ring
3.	G6400-12 GR1467	1 -	Connector W/O-Ring, 1 1/16"-12 Male JIC To O-Ring O-Ring
4.	G6500-06	1	Swivel Elbow, 90°, 9/16"-18 Male JIC To Female
5.	G6400-06 GR1045	1 -	Connector W/O-Ring, 9/16"-18 Male JIC To O-Ring O-Ring
6.	G6502-12	1	Swivel Elbow, 45°, 1 1/16"-12 Male JIC To Female

OPTIONAL FLOW CONTROL NEEDLE VALVE KIT

(A11650)

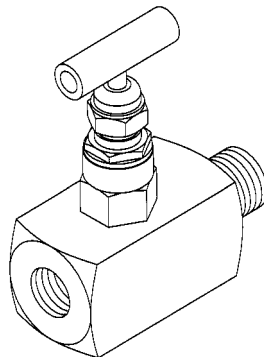

ITEM	PART NO.	QTY.	DESCRIPTION
1.	G1K426	-	Needle Valve Kit W/Instructions

VACUUM FAN MOTOR VALVE BLOCK ASSEMBLY (Located Below Vacuum Fan Motor Assembly)

(A11068cc/A11340a)

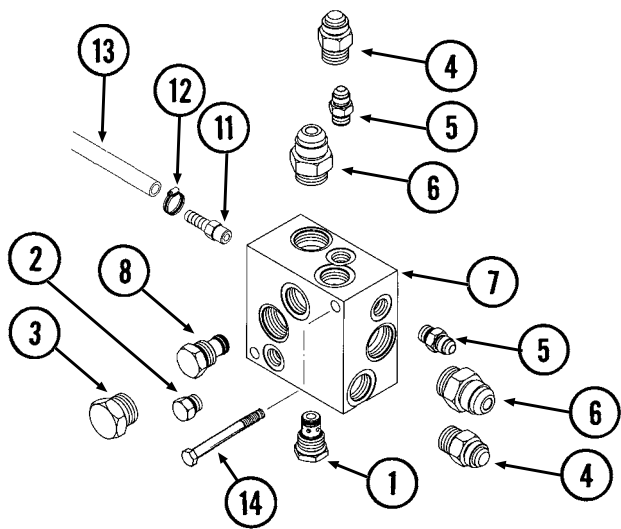

Conventional Planters

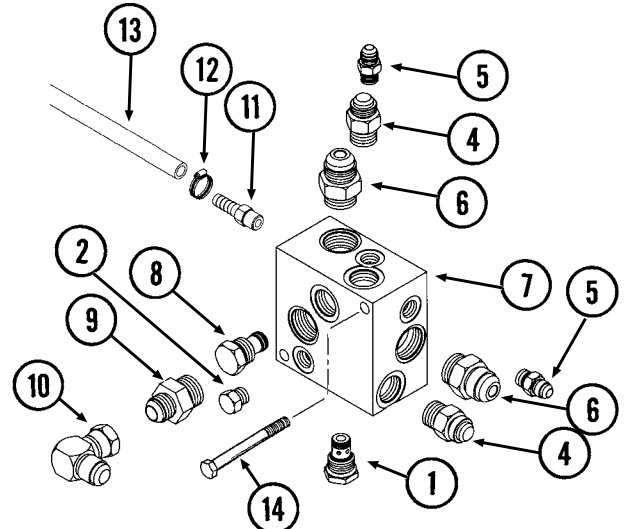

SDS Planters

ITEM	PART NO.	QTY.	DESCRIPTION
1.	GA4293	1	Check Valve
	GR0764	-	Seal Kit, Includes: (2) O-Rings, (1) BU Ring
2.	G6408-06	1	Plug W/O-Ring, 1/16"-18 O-Ring
	GR1045	-	O-Ring
3.	G6408-12	1	Plug W/O-Ring, 1 1/16"-12 O-Ring
	GR1467	-	O-Ring
4.	G6400-10	2	Connector W/O-Ring, 7/8"-14 Male JIC To O-Ring
	GR1466	-	O-Ring
5.	G6400-06	2	Connector W/O-Ring, 9/16"-18 Male JIC To O-Ring
	GR1045	-	O-Ring
6.	G6400-12	2	Connector W/O-Ring, 1 1/16"-12 Male JIC To O-Ring
	GR1467	-	O-Ring
7.	GD16188	1	Valve Block
8.	GA11934	1	Relief Valve Cartridge
9.	G6400-10-12	1	Connector W/O-Ring, 7/8"-14 Male JIC To 1 1/16"-12 O-Ring
	GR1467	-	O-Ring
10.	G6500-10	1	Swivel Elbow, 90°, 7/8"-14 Male JIC To Female
11.	GD6279-05	1	Clear Plastic Tubing, 9/16" O.D. x 60"
12.	G10681	1	Hose Clamp, No. 6
13.	GD11700	1	Adapter, 1/4" NPT To 3/8" Barb
14.	G10061	2	Hex Head Cap Screw, 3/8"-16 x 3 1/2"
	G10210	2	Washer, 3/8" USS
	G10229	2	Lock Washer, 3/8"
	G10101	2	Hex Nut, 3/8"-16

MANIFOLDS AND DISTRIBUTION HOSES

(TWL307)

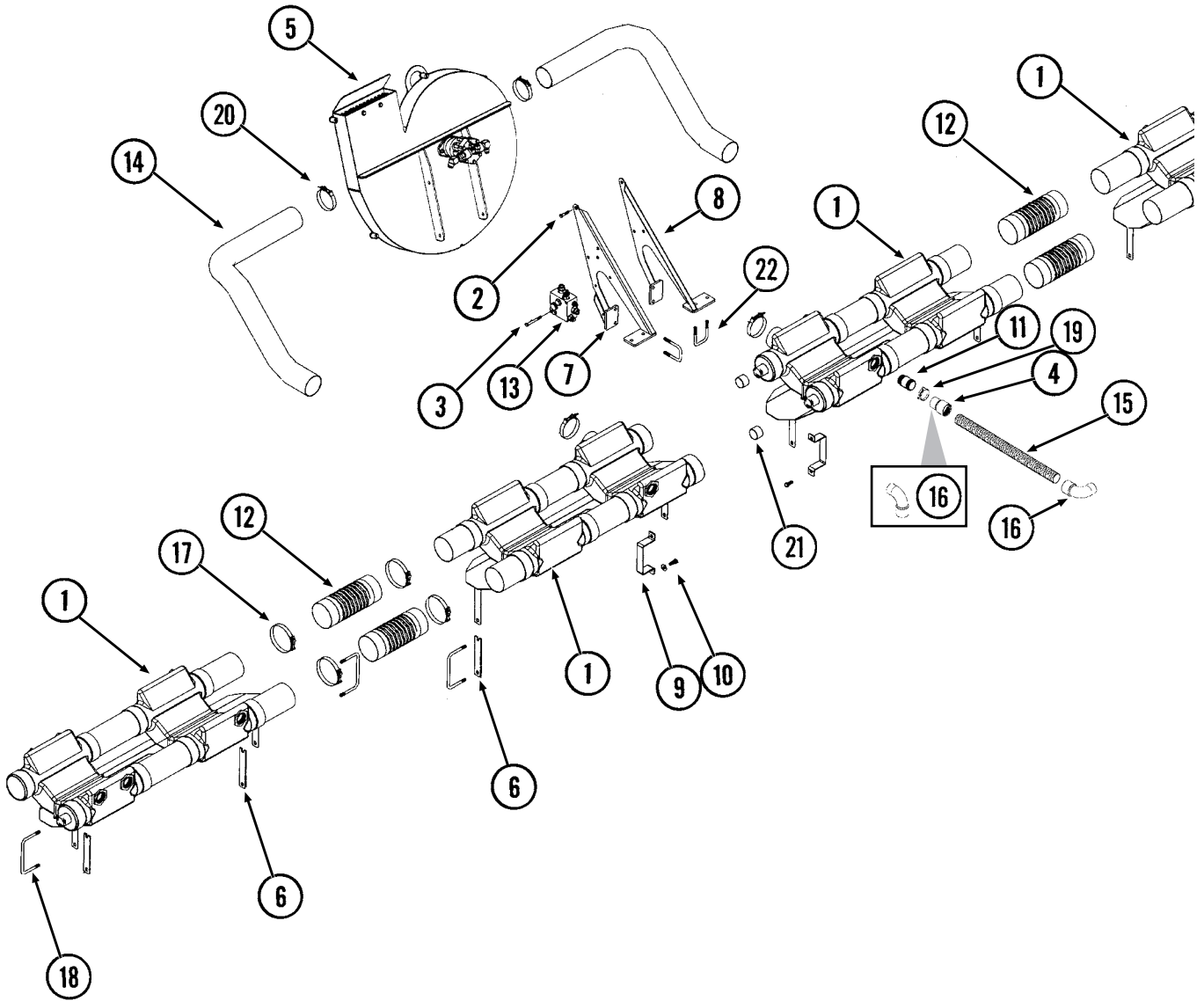

MANIFOLDS AND DISTRIBUTION HOSES

ITEM	PART NO.	QTY.	DESCRIPTION
1.		-	See "Manifold Assemblies", Pages P48 And P49
2.	G10037	4	Hex Head Cap Screw, 1/2"-13 x 1 1/4"
	G10228	4	Lock Washer, 1/2"
	G10102	4	Hex Nut, 1/2"-13
3.	G10061	2	Hex Head Cap Screw, 3/8"-16 x 3 1/2"
	G10210	2	Washer, 3/8" USS
	G10229	2	Lock Washer, 3/8"
	G10101	2	Hex Nut, 3/8"-16
4.	GD14627	-	Coupler, 2"
5.		-	See "Digital Vacuum Gauge, Analog Vacuum Gauge And Vacuum Fan Assembly", Pages P42 And P43
6.	GD16167	6-8	Overlay
7.	GA10783	1	Mount, L.H.
8.	GA10784	1	Mount, R.H.
9.	GD16480	2	Bracket
10.	G10037	4	Hex Head Cap Screw, 1/2"-13 x 1 1/4"
	G10228	4	Lock Washer, 1/2"
	G10102	4	Hex Nut, 1/2"-13
11.	GD16462	18-26	Nipple, 2"
12.	GD15867-01	4	Hose, 5" x 13"
13.		-	See "Vacuum Fan Motor Valve Block", Page P45
14.	GD15867-07	2	Hose, 5" x 60"
15.	GD15792-02	-	Hose, 2" x 23"
	GD15792-04	-	Hose, 2" x 36"
	GD15792-06	-	Hose, 2" x 42"
	GD15792-09	-	Hose, 2" x 30"
	GD15792-11	-	Hose, 2" x 70"
	GD15792-13	-	Hose, 2" x 50"
	GD15792-14	-	Hose, 2" x 46"
	GD15792-13	-	Hose, 2" x 50"
	GD15792-16	-	Hose, 2" x 55"
	GD15792-17	-	Hose, 2" x 80"
16.	GD14626	-	Elbow, 90°, 2"
17.	G11188	8	T-Bolt Clamp, 5 1/4"
18.	GD16460	4-6	U-Bolt, 7" x 3" x 1/2"-13
	G10228	8-12	Lock Washer, 1/2"
	G10102	8-12	Hex Nut, 1/2"-13
19.	G10676	-	Hose Clamp, No. 36
20.	G11188	4	T-Bolt Clamp, 5 1/4"
21.	G11147	-	Cap, 2"
22.	GD1138	4	U-Bolt, 2 1/2" x 2 1/2" x 1/2"-13
	G10216	8	Washer, 1/2" USS
	G10228	8	Lock Washer, 1/2"
	G10102	8	Hex Nut, 1/2"-13

MANIFOLD ASSEMBLIES

(A11343/A11335/A11337a/A11336a/A11342/A11334

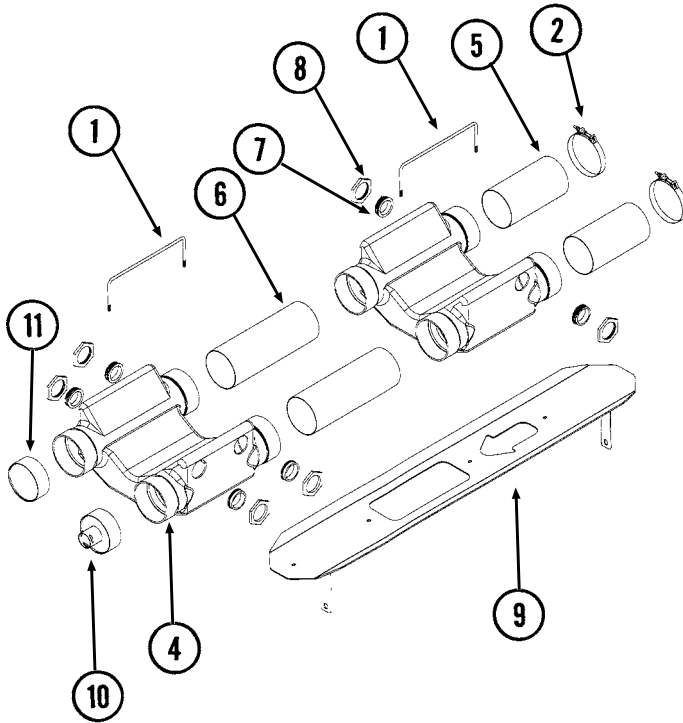

L.H. Wing Manifold, 12 Row 30"

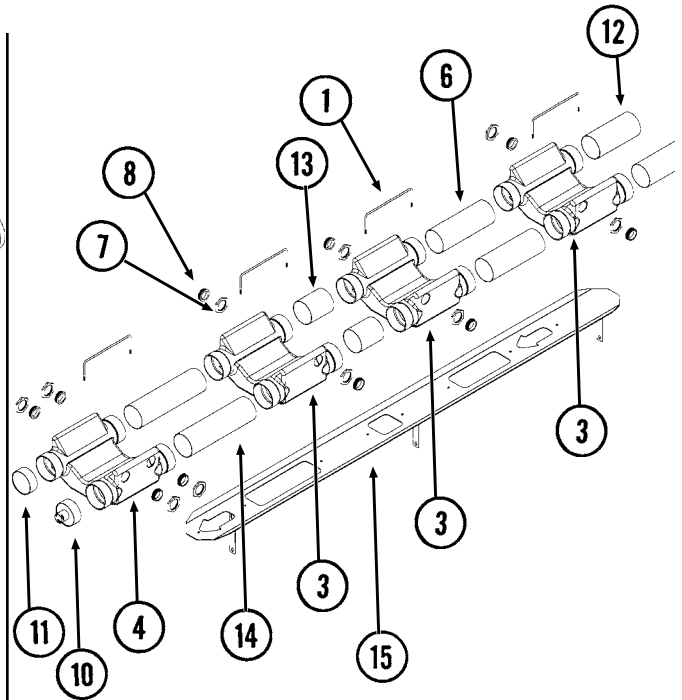

L.H. Wing Manifold, 16 Row 30"

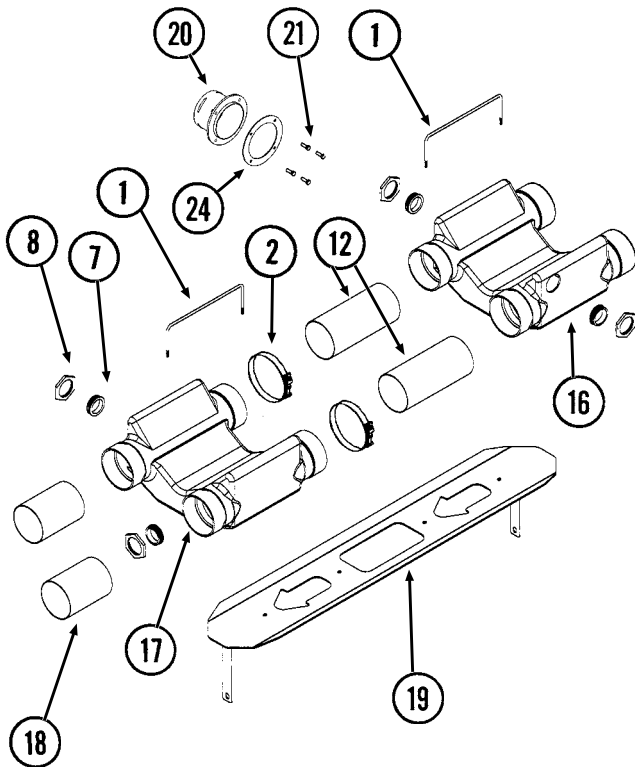

**L.H. Center Manifold,
12 Row 30" And 16 Row 30"**

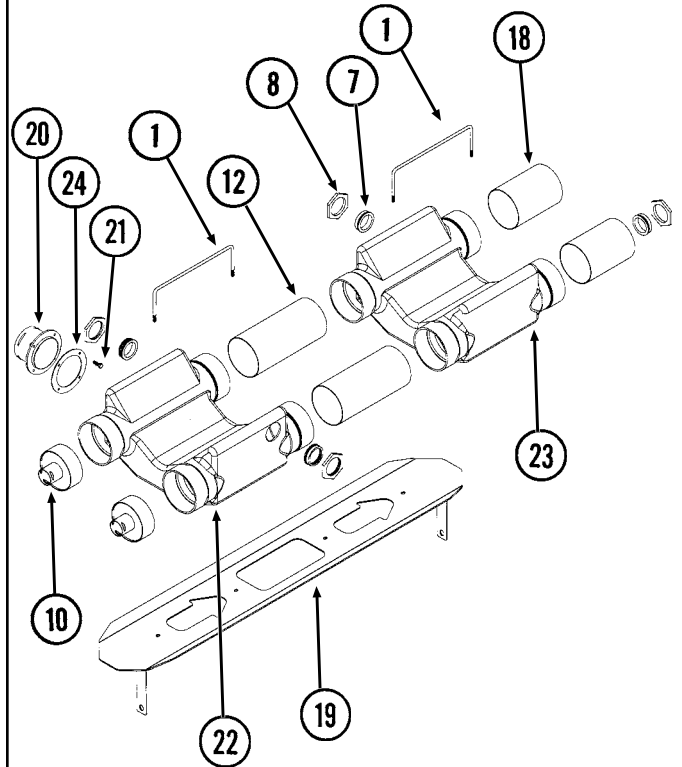

**R.H. Center Manifold,
12 Row 30" And 16 Row 30"**

MANIFOLD ASSEMBLIES

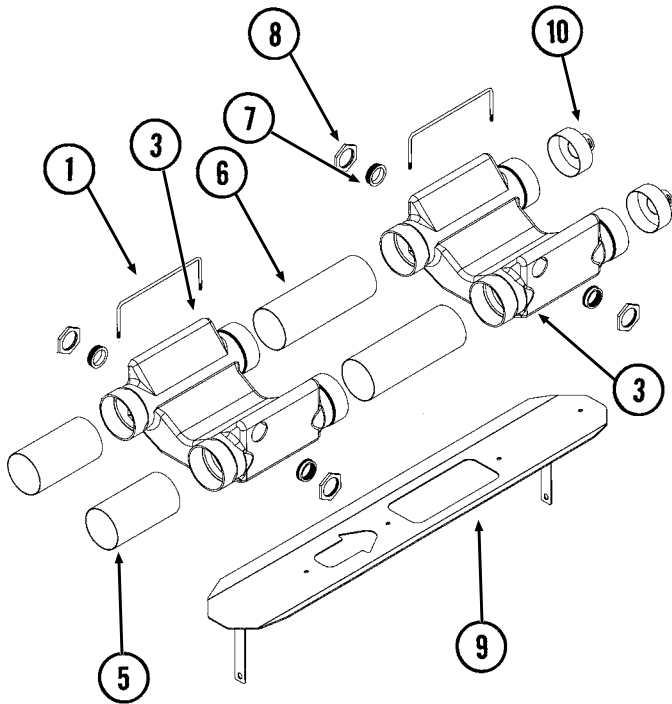

R.H. Wing Manifold, 12 Row 30"

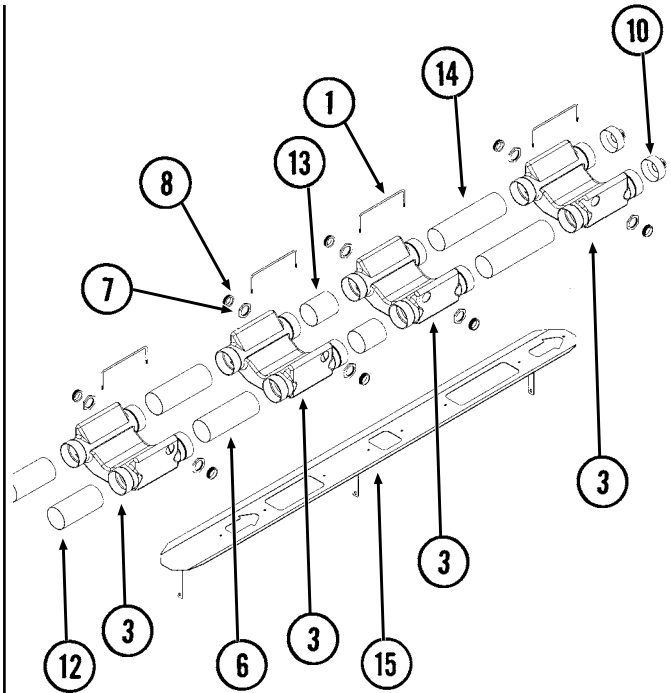

R.H. Wing Manifold, 16 Row 30"

ITEM	PART NO.	QTY.	DESCRIPTION
1.	GD16461	-	U-Bolt, 12 1/4" x 4" x 5/16"-18
	G10232	-	Lock Washer, 5/16"
	G10106	-	Hex Nut, 5/16"-18
2.	G11188	-	T-Bolt Clamp, 5 1/4"
3.	GD16468	-	Manifold
4.	GD16469	-	Manifold, L.H. End
5.	GD16119-11	-	Tube, 5" O.D. x 9 1/2"
6.	GD16119-04	-	Tube, 5" O.D. x 14"
7.	GD16463	-	Nut
8.	GD16464	-	Bung
9.	GA11341	-	Saddle
10.	GA10989	-	Outlet End, 5"
11.	GA10990	-	Manifold End
12.	GD16119-02	-	Tube, 5" O.D. x 11"
13.	GD16119-01	-	Tube, 5" O.D. x 6"
14.	GD16119-03	-	Tube, 5" O.D. x 17 1/2"
15.	GA11332	-	Saddle
16.	GD16471	-	Manifold, L.H. Center
17.	GD16473	-	Manifold, L.H.
18.	GD16119-05	-	Tube, 5" O.D. x 7"
19.	GA11333	-	Saddle
20.	GA12150	-	Outlet, 5" I.D.
21.	G10019	-	Hex Head Cap Screw, 5/16"-18 x 1"
	G10232	-	Lock Washer, 5/16"
	G10106	-	Hex Nut, 5/16"-18
22.	GD16470	-	Manifold, R.H. Center
23.	GD16472	-	Manifold, R.H.
24.	GD17212	-	Gasket, 5" I.D. x 7" O.D.

PTO PUMP DRIVE AND OIL COOLER OPTION

(TWL302a/D16644/TWL1j/TWL303/TWL306)

12 Row 30" Shown

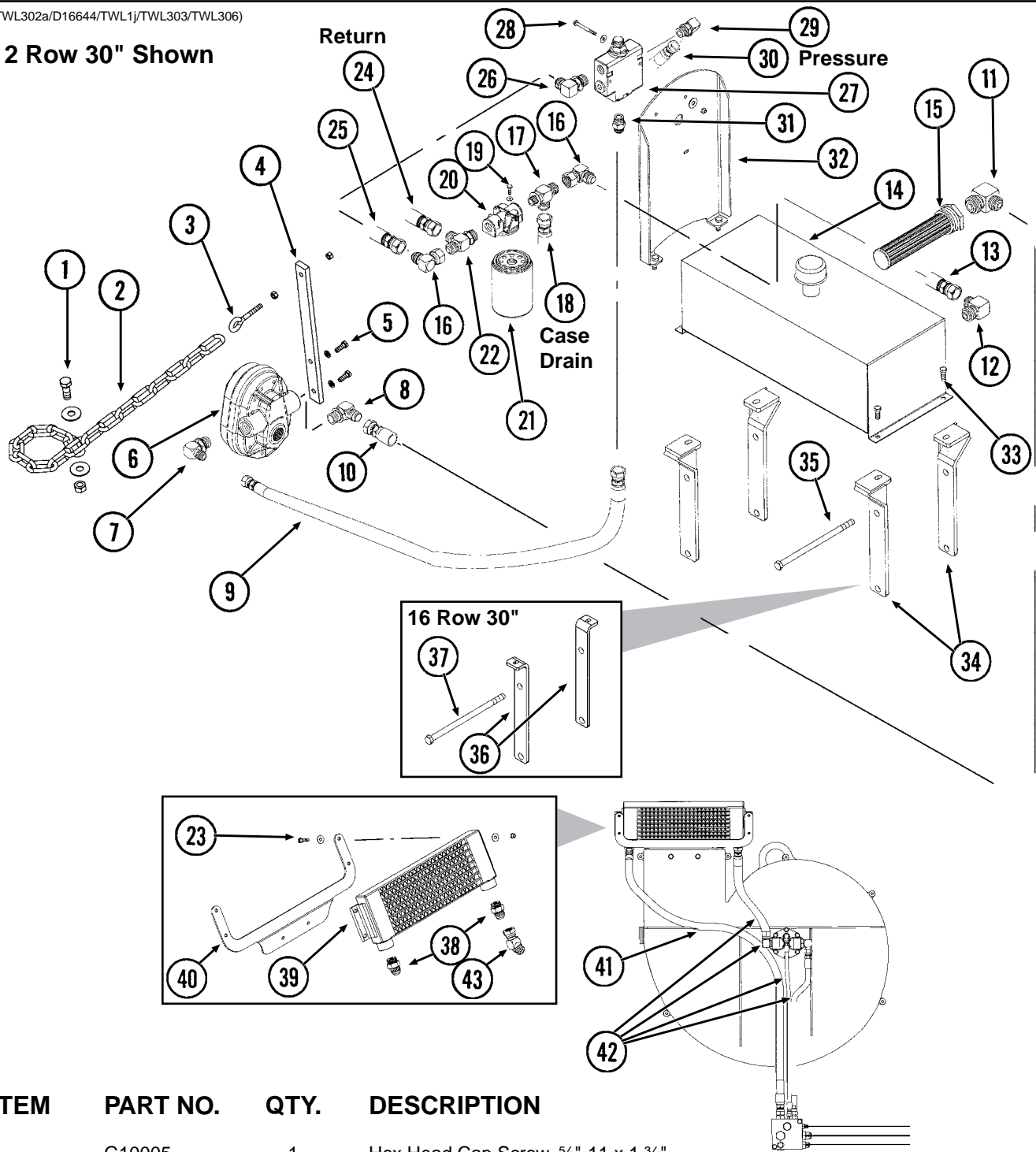

ITEM	PART NO.	QTY.	DESCRIPTION
1.	G10005	1	Hex Head Cap Screw, 5/8"-11 x 1 3/4"
	G10217	2	Washer, 5/8" USS
	G10107	1	Lock Nut, 5/8"-11
2.	G3302-09	1	Coil Chain, No. 9/0, 17 Links
3.	GD16035	1	Eyebolt, 3/8"-16 x 4"
	G10101	2	Hex Nut, 3/8"-16
4.	GD16036	1	Anti-Rotation Bracket
5.	G10001	2	Hex Head Cap Screw, 3/8"-16 x 1"
	G10229	2	Lock Washer, 3/8"
6.	GA10919	1	PTO Pump
7.	G6801-10-12	1	Elbow W/O-Ring, 90°, 7/8"-14 Male JIC To 1 1/16"-12 O-Ring
	GR1467	-	O-Ring
8.	G6801-16	1	Elbow W/O-Ring, 90°, 1 5/16"-12 Female JIC To O-Ring
	GR1786	-	O-Ring

PTO PUMP DRIVE AND OIL COOLER OPTION

ITEM	PART NO.	QTY.	DESCRIPTION
9.	*A1464	1	Hose Assembly, 1/2" x 72"
10.	*A6201	1	Hose Assembly, 1" x 72"
11.	G2501-16-20	1	Elbow, 90°, 1 5/16"-12 Male JIC To 1 1/4" NPT
12.	G2501-12-16	1	Elbow, 90°, 1 1/16"-12 Male JIC To 1" NPT
13.	*A3371	1	Hose Assembly, 3/4" x 25"
14.	GA12802	1	Reservoir, W/Breather, 10 Gallon
	GR1834	-	Breather
15.	GD16040	1	Strainer
16.	G6500-12	2	Swivel Elbow, 90°, 1 1/16"-12 Male JIC To Female
17.	G6804-12-12-08	1	Adjustable Tee W/O-Ring, 1 1/16"-12 To 1 1/16"-12 Male O-Ring To 3/4"-16
	GR1467	-	O-Ring
18.	*A3279	-	Hose Assembly, 3/8" x 138", 12 Row 30"
	*A3280	-	Hose Assembly, 3/8" x 190", 16 Row 30"
19.	G10023	2	Hex Head Cap Screw, 1/4"-20 x 3/4"
	G10227	2	Lock Washer, 1/4"
20.	GD16038	1	Filter Head
21.	GD16037	1	Filter, 10 Micron
22.	G6804-12	1	Adjustable Tee W/O-Ring, 1 1/16"-12 Male JIC To O-Ring
	GR1467	-	O-Ring
23.	G10171	4	Hex Head Cap Screw, 5/16"-18 x 1 1/4"
	G10219	8	Washer, 5/16" USS
	G10109	4	Lock Nut, 5/16"-18, Grade 8
24.	*A3373	-	Hose Assembly, 3/4" x 138", 12 Row 30"
	*A3374	-	Hose Assembly, 3/4" x 190", 16 Row 30"
25.	*A3351	1	Hose Assembly, 3/4" x 20"
26.	G6801-12-10	1	Elbow W/O-Ring, 90°, 1 1/16"-12 Male JIC To 7/8"-14 O-Ring
	GR1466	-	O-Ring
27.	GA10918	1	Flow Control Valve
28.	G10403	2	Hex Head Cap Screw, 1/4"-20 x 2 1/2"
	G10209	4	Washer, 1/4" USS
	G10110	2	Lock Nut, 1/4"-20, Grade B
29.	G6801-10	1	Elbow W/O-Ring, 90°, 7/8"-14 Male JIC To O-Ring
	GR1466	-	O-Ring
30.	*A8281	-	Hose Assembly, 1/2" x 138", 12 Row 30"
	*A8282	-	Hose Assembly, 1/2" x 190", 16 Row 30"
31.	G6400-10	1	Connector W/O-Ring, 7/8"-14 Male JIC To O-Ring
	GR1466	-	O-Ring
32.	GA11523	1	Mounting Bracket
33.	G10001	2	Hex Head Cap Screw, 3/8"-16 x 1"
	G10210	4	Washer, 3/8" USS
	G10108	4	Lock Nut, 3/8"-16
34.	GA11544	4	Bracket, 12", 8 Row 36"/38" And 12 Row 30"/36"/38"
35.	G10148	4	Hex Head Cap Screw, 1/2"-13 x 9 1/2"
	G10228	4	Lock Washer, 1/2"
	G10102	4	Hex Nut, 1/2"-13
36.	GD16644	4	Bracket, 14 1/2", 16 Row 30"
37.	G11158	4	Hex Head Cap Screw, 1/2"-13 x 11 1/2"
	G10228	4	Lock Washer, 1/2"
	G10102	4	Hex Nut, 1/2"-13
38.	G6400-12	2	Connector W/O-Ring, 1 1/16"-12 Male JIC To O-Ring
	GR1467	-	O-Ring
39.	GA10917	1	Oil Cooler
40.	GD16608	1	Bracket
41.	*A3369	1	Hose Assembly, 3/4" x 40"
42.		-	See "Hydraulic Hoses And Fittings On Planter Frame", Pages P114-P117
43.	G6502-12	1	Swivel Elbow, 45°, 1 1/16"-12 Male JIC To Female

* Hydraulic hose is not stocked by KINZE® Repair Parts, but can be made available on a special order basis. Call for quote.

OUTER HITCH/SAFETY CHAIN

PHA038/PHA025(TWL1g/WGN47a/TWL1j)

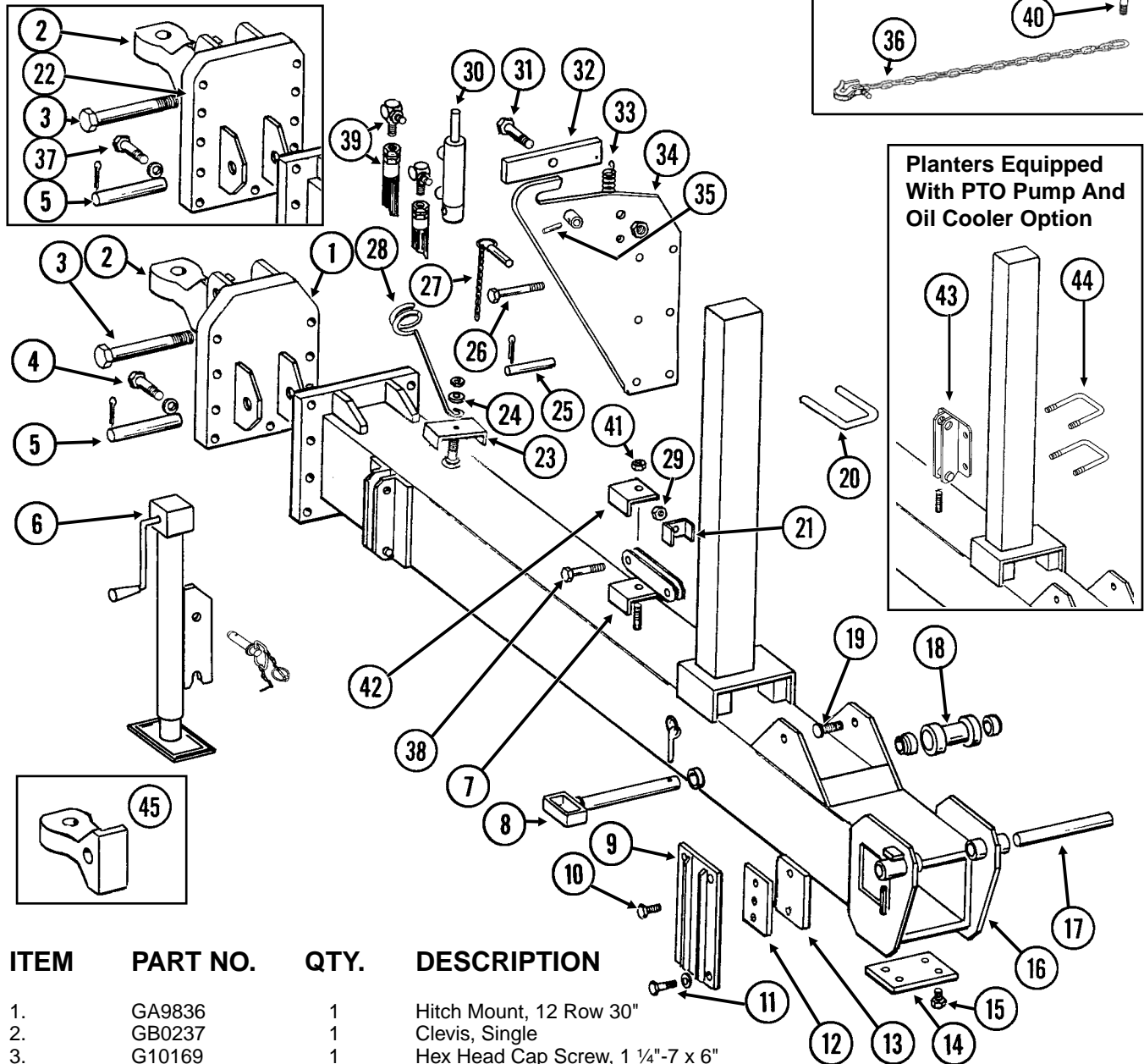

ITEM	PART NO.	QTY.	DESCRIPTION
1.	GA9836	1	Hitch Mount, 12 Row 30"
2.	GB0237	1	Clevis, Single
3.	G10169	1	Hex Head Cap Screw, 1 1/4"-7 x 6"
	G10157	1	Lock Nut, 1 1/4"-7
4.	G10009	9	Hex Head Cap Screw, 5/8"-11 x 2 1/2"
	G10230	9	Lock Washer, 5/8"
	G10104	9	Hex Nut, 5/8"-11
5.	GD5173	1	Pin, 1 1/4" x 5 1/8"
	G10462	2	Cotter Pin, 3/16" x 2"
6.	GA4994	1	Jack Assembly Complete
	GA4995	-	Detent Pin Assembly
	GR0517	-	Pin
	GR0516	-	Crank Assembly
	GR0515	-	Bevel Gear Set, Includes: (2) Bevel Gears, (1) Gear Pin, (1) Groove Pin
7.	GA5842	1	Bracket, Jack Mount
	GD8189	-	Rubber Pad
8.	GA4402	1	Safety Pin, 12 3/4", 12 Row 30"
	GA4845	-	Safety Pin, 14 3/4", 16 Row 30"
	GD2557	-	Lynch Pin, 7/16"
9.	GA7029	2	Wear Mount, 12 Row 30"
	GA7084	-	Wear Mount, L.H., 16 Row 30"
	GA7085	-	Wear Mount, R.H., 16 Row 30"
	GA7083	-	Wear Pad Retainer, 16 Row 30"

OUTER HITCH/SAFETY CHAIN

ITEM	PART NO.	QTY.	DESCRIPTION
10.	G10016	-	Hex Head Cap Screw, 1/2"-13 x 2"
	G10014	-	Hex Head Cap Screw, 1/2"-13 x 1"
	G10216	-	Washer, 1/2" USS
	G10228	-	Lock Washer, 1/2"
11.	G10017	8	Hex Head Cap Screw, 1/2"-13 x 1 1/2", 12 Row 30"
	G10016	10	Hex Head Cap Screw, 1/2"-13 x 2", 16 Row 30"
	G10228	8-10	Lock Washer, 1/2"
	G10102	8-10	Hex Nut, 1/2"-13
12.	GD5154	-	Shim, 4" x 4" (As Required), All Sizes
	GD3501	-	Shim, 4" x 6" (As Required), 16 Row 30"
13.	GD9959	-	Wear Pad, Nylatron, 4" x 4" (As Required), All Sizes
	GD9960	-	Wear Pad, Nylatron, 4" x 6" (As Required), 16 Row 30"
14.	GD7519	3	Shim, 16 Gauge, 16 Row 30" Only
	GD7518	1	Shim, 3/8", 16 Row 30" Only
15.	G10014	4	Hex Head Cap Screw, 1/2"-13 x 1"
	G10228	4	Lock Washer, 1/2"
	G10216	4	Washer, 1/2" USS
16.	A7010	-	Outer Hitch, "Y", 97", 12 Row 30" (Non-Stock Item)
	A7088	-	Outer Hitch, "Y", 127 1/2", 16 Row 30" (Non-Stock Item)
17.	GD5804	1	Pin, 1 1/4" x 12", 12 Row 30"
	GD7251	1	Pin, 1 1/4" x 14", 16 Row 30"
	G10610	2	Spring Pin, 3/8" x 2"
18.	GA4418	1	Roller W/Bronze Bushings, 12 Row 30"
	GA4842	-	Roller W/Bronze Bushings, 16 Row 30"
	GD6556	1	Bronze Bushing
19.			See "Hose Take-Up", Pages P64 And P65
20.	GD9953	3	U-Bolt, 3" x 4" x 5/8"-11
	G10205	1	Washer, 5/8" SAE
	G10230	6	Lock Washer, 5/8"
	G10104	6	Hex Nut, 5/8"-11
21.	GD5892	2	Hose Clamp, 5/8" x 1 1/2" x 1 1/2"
22.	GA9837	-	Hitch Mount, 16 Row 30"
23.	GD8188	-	Clamp, 7/8" x 3" x 5 3/8"
	GD8189	-	Rubber Pad
24.	G10216	1	Washer, 1/2" USS
	G10217	1	Washer, 5/8" USS
	G10111	1	Lock Nut, 1/2"-13
25.	GD7137	1	Pin, 3/4" x 3 3/8"
	G10457	2	Cotter Pin, 5/32" x 1 1/2"
26.	G10809	1	Hex Head Cap Screw, 3/8"-16 x 3 1/4"
	GD2971-09	1	Sleeve, 2" Long
	G10108	1	Lock Nut, 3/8"-16
27.	GA7022	1	Detent Pin W/Chain (Transport Latch Locking Pin)
28.	GD8260	1	Hose Holder
29.	G10108	1	Lock Nut, 3/8"-16
30.			See "Transport Latch Cylinder", Page P98
31.	G10006	1	Hex Head Cap Screw, 5/8"-11 x 2 1/4"
	GB0218	1	Bushing, 2 1/32" I.D. x 7/8" O.D. x 1 9/32" Long
	GD7805	1	Special Washer, 5/8", Hardened
	G10107	1	Lock Nut, 5/8"-11
32.	GA7016	1	Catch Bar
33.	GD5857	1	Spring
34.	GA7433	1	Transport Latch
35.	G10765	-	Spring Pin, 1/4" x 1"
36.	GA7533	1	Safety Chain, 1/2"
	G1K412	-	Safety Chain Repair Kit, Includes: (1) Hook, (1) Flat Washer, (1) Latch Pin, (1) Safety Latch, (1) Retaining Ring
37.	G10802	11	Hex Head Cap Screw, 3/4"-10 x 2 3/4"
	G10231	11	Lock Washer, 3/4"
	G10105	11	Hex Nut, 3/4"-10
38.	G10026	1	Hex Head Cap Screw, 3/4"-10 x 2"
	G10112	1	Lock Nut, 3/4"-10
39.		-	See "Hydraulic Hoses And Fittings On Hitch", Pages P110-P113
40.	G11058	1	Hex Head Cap Screw, 1 1/4"-7 x 3"
	GD10646	1	Special Washer
	G10226	1	Washer, 1 1/4" SAE
	G10157	1	Lock Nut, 1 1/4"-7
41.	G10111	1	Lock Nut, 1/2"-13
42.	GD14121	1	Hose Clamp, 7/8" x 3 1/2"
43.	GA11528	1	Bracket
44.	GD16642	2	U-Bolt, 3" x 4" x 1/2"-13
	G10228	4	Lock Washer, 1/2"
	G10102	4	Hex Nut, 1/2"-13
45.	GB0292	-	Hitch Clevis, Single (2" Pin)

2-POINT HITCH OPTION

(A12406)

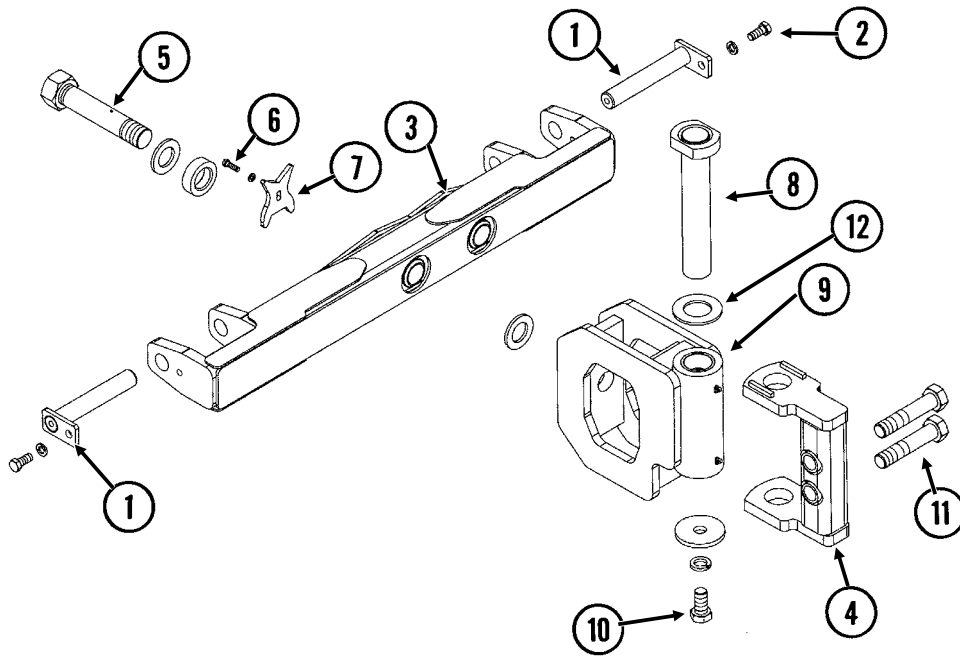

2-POINT HITCH OPTION

ITEM	PART NO.	QTY.	DESCRIPTION
1.	GA11079	2	Hammer Strap, Category 3N And 3
2.	G10007	2	Hex Head Cap Screw, 5/8"-11 x 1 1/2"
	G10230	2	Lock Washer, 5/8"
3.	GA12164	1	Hitch Bar
4.	GA12165	1	Pivot Mount
5.	GA11082	1	Pivot Bolt W/Grease Fitting, 1 3/4" x 10 3/8" (Total Length)
	G10640	-	Grease Fitting, 1/4"-28
	GD16303	2	Washer, 3" O.D. x 1 25/32" x 1/4" Thick
	GD16226	1	Sleeve, 3" O.D. x 1 25/32" x 29/32" Thick
6.	G10005	1	Hex Head Cap Screw, 5/8"-11 x 1 1/4"
	G10217	1	Washer, 5/8" USS
7.	GD15100	1	Pivot Lock
8.	GA12163	1	Pin, 13 3/8"
9.	GA11083	1	Hitch Pivot W/Bushings And Grease Fittings
	GD14562	2	Hardened Bushing, 2 3/4" O.D. x 2 1/4" I.D. x 3"
	G10779	2	Grease Fitting, 90°, 1/4"-28
10	G11223	1	Hex Head Cap Screw, 1"-8 x 2"
	G10118	1	Lock Washer, 1"
	GD17245	1	Washer, 4" O.D. x 1 1/32" I.D. x 3/8"
11.	G10169	2	Hex Head Cap Screw, 1 1/4"-7 x 6"
	G10157	2	Lock Nut, 1 1/4"-7
12.	GD15725	1	Washer, 4" O.D. x 2 1/4" I.D. x 1/4"

INNER HITCH/UNDERCARRIAGE ASSEMBLY (Front)

(A9999a)

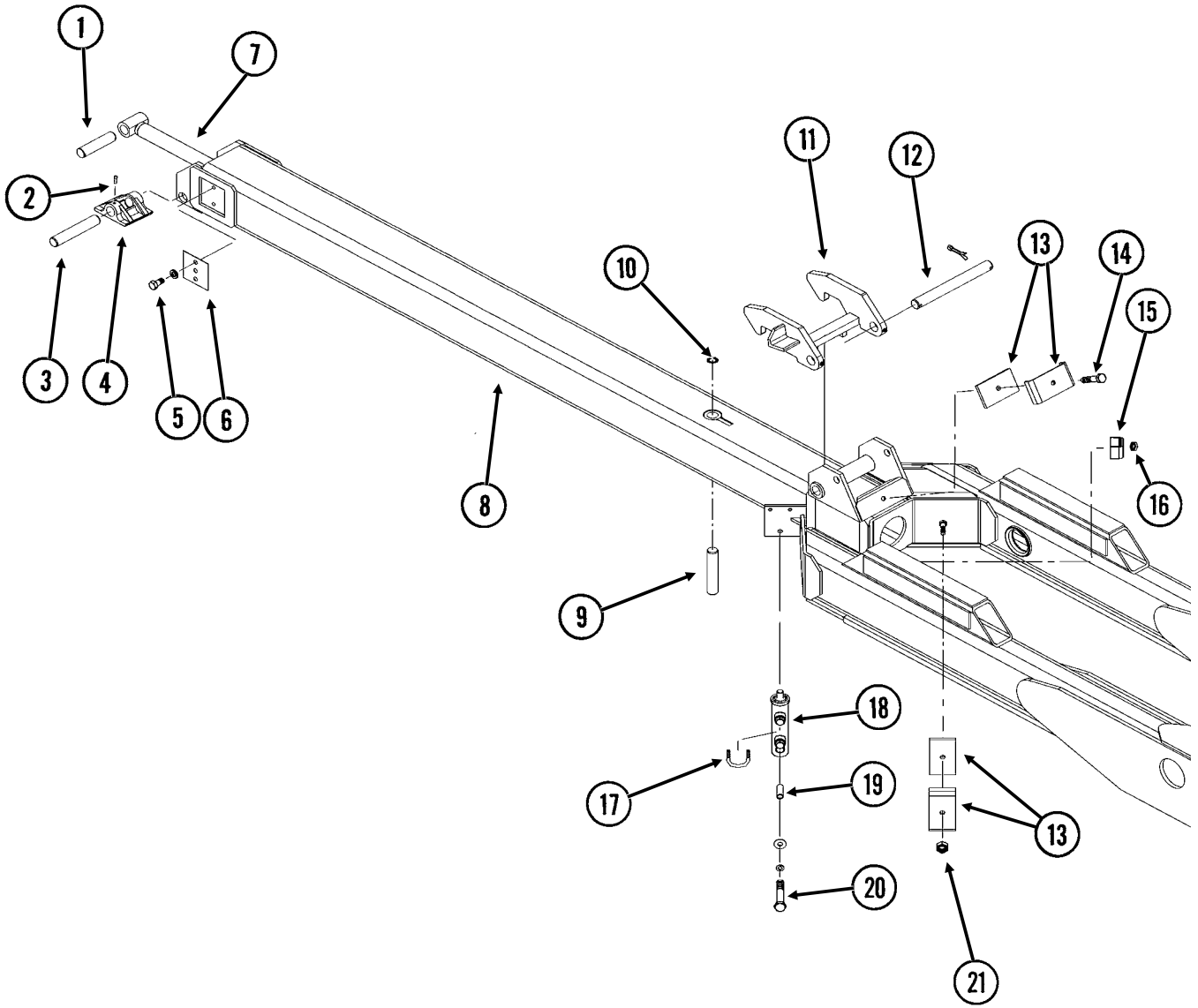

INNER HITCH/UNDERCARRIAGE ASSEMBLY (Front)

ITEM	PART NO.	QTY.	DESCRIPTION
1.	GD5173	1	Pin, 1 1/4" x 5 1/8"
	G10462	1	Cotter Pin, 3/16" x 2"
2.	G10131	1	Square Head Set Screw, 5/16"-18 x 3/4"
3.	GD3537-11	1	Shaft, 1 1/4" x 7", 12 Row 30"
	GD3537-12	-	Shaft, 1 1/4" x 8", 16 Row 30"
4.	GB0246	1	Shoe
5.	G10017	4	Hex Head Cap Screw, 1/2"-13 x 1 1/2", 16 Row 30"
	G10014	-	Hex Head Cap Screw, 1/2"-13 x 1", 12 Row 30"
	G10228	4-6	Lock Washer, 1/2"
6.	GD9959	2	Wear Pad, Nylatron, 4" x 4"
	GD5154	4	Shim, 4" x 4"
7.		-	See "Tongue Cylinder", Page P99
8.		-	Inner Hitch/Undercarriage, See "Inner Hitch/Undercarriage Assembly (Rear)", Pages P58 And P59
9.	GD3537-17	1	Shaft, 1 1/4" x 6 3/8", 12 Row 30"
	GD3537-18	-	Shaft, 1 1/4" x 7 3/8", 16 Row 30"
10.	G10894	-	External Washer
11.	GA7423	1	Tongue Hook W/Grease Fittings, 12 Row 30"
	GA7424	-	Tongue Hook W/Grease Fittings, 16 Row 30"
	G10641	-	Grease Fitting, 1/8" NPT
12.	GD5804	1	Pin, 1 1/4" x 12", 12 Row 30"
	GD7883	-	Pin, 1 1/4" x 14 1/2", 16 Row 30"
	G10468	2	Cotter Pin, 3/8" x 2"
13.	GD8188	-	Clamp, 7/8" x 3" x 5 3/8"
	GD8189	-	Rubber Pad
14.	G11077	1	Hex Head Cap Screw, 1/2"-13 x 2 1/4"
	G10111	1	Lock Nut, 1/2"-13
15.	GD5892	-	Hose Clamp, 5/8" x 1 1/2" x 1 1/2"
16.	G10111	1	Lock Nut, 1/2"-13
17.	GD10530	1	U-Bolt, 2 1/8" x 1 7/8" x 3/8"-16
	G10229	2	Lock Washer, 3/8"
	G10101	2	Hex Nut, 3/8"-16
18.		-	See "Tongue Lock Cylinder", Page P98
19.	GD10538-01	1	Sleeve
20.	G10585	1	Hex Head Cap Screw, 1/2"-13 x 3 1/4"
	G10216	1	Washer, 1/2" USS
	G10228	1	Lock Washer, 1/2"
	G10102	1	Hex Nut, 1/2"-13
21.	G10108	1	Lock Nut, 3/8"-16

INNER HITCH/UNDERCARRIAGE ASSEMBLY (Rear)

(A9999aaaa)

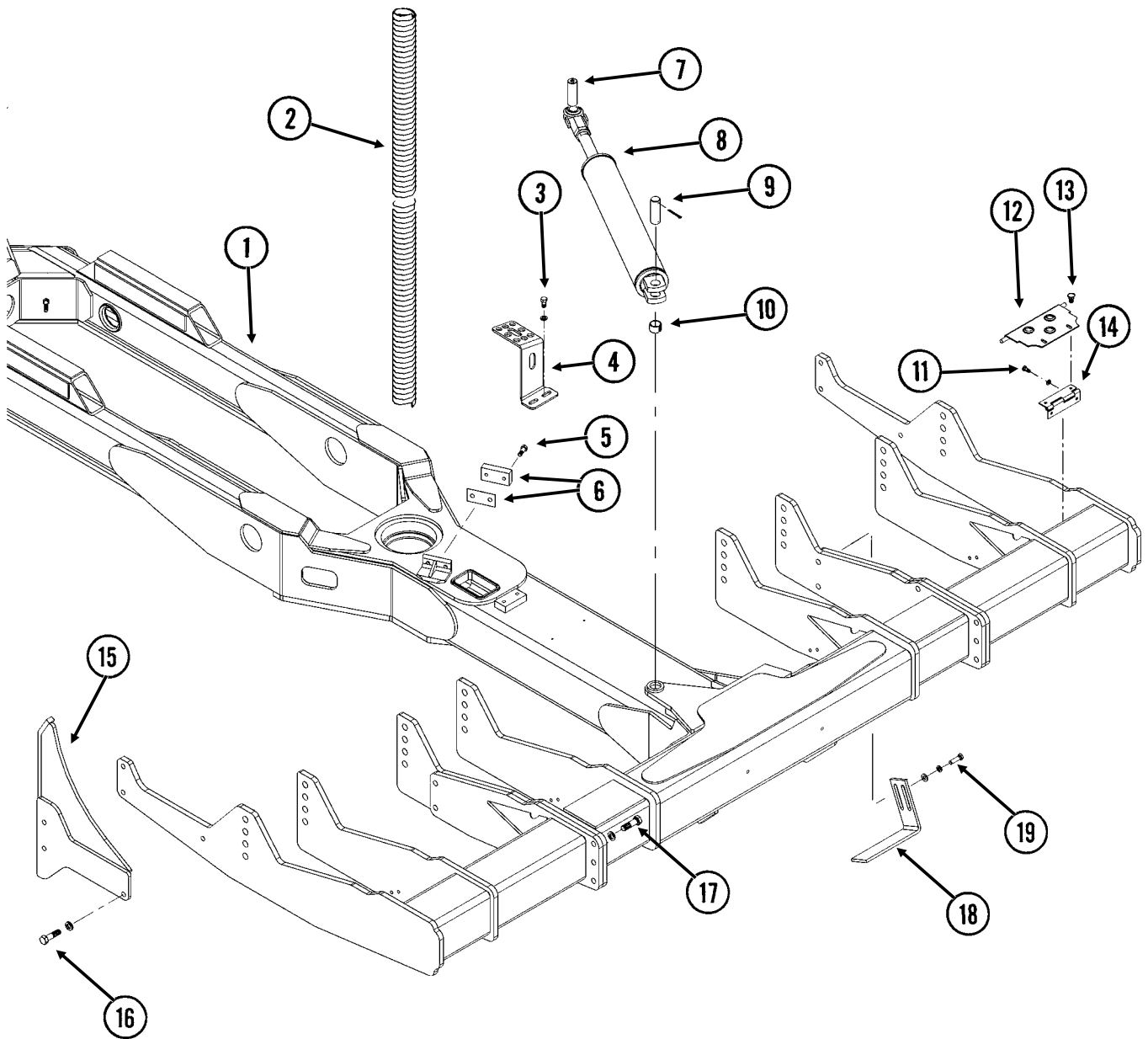

INNER HITCH/UNDERCARRIAGE ASSEMBLY (Rear)

ITEM	PART NO.	QTY.	DESCRIPTION
1.	A10093	-	Inner Hitch/Undercarriage W/Stub Axles, 254", 12 Row 30" (Shown) (Non-Stock Item)
	A10080	-	Inner Hitch/Undercarriage W/Stub Axles, 290", 16 Row 30" (Non-Stock Item)
	GA10557	-	Stub Axle, L.H.
	GA10558	-	Stub Axle, R.H.
2.	GD9129-01	1	Hose Protector, 48"
3.	G10014	2	Hex Head Cap Screw, 1/2"-13 x 1"
	G10228	2	Lock Washer, 1/2"
4.	GD16067	1	Bulkhead Plate
5.	G10017	2	Hex Head Cap Screw, 1/2"-13 x 1 1/2"
6.	GD14547	1	Tap Block, 1" x 2" x 4"
	GD14418	4	Shim, 2" x 4", 22 Gauge (As Required)
	GD14419	6	Shim, 2" x 4", 16 Gauge
7.		-	See "Center Pivot", Pages P70 And P71
8.		-	See "Rotation Cylinder", Page P91
9.	GD10064	1	Pin, 1 1/4" x 5 1/4"
	G10460	2	Cotter Pin, 1/4" x 2"
10.	GD11751	1	Steel Bushing, 1" Wide
11.	G10043	8	Hex Head Cap Screw, 5/16"-18 x 3/4"
	G10232	8	Lock Washer, 5/16"
12.	GA10077	4	Hinged Step
13.	G10312	8	Carriage Bolt, 5/16"-18 x 3/4"
	G10232	8	Lock Washer, 5/16"
	G10106	8	Hex Nut, 5/16"-18
14.	GD13329	4	Hinge
15.	GA10071	1	Roller Guide, L.H. (Shown)
	GA10070	-	Roller Guide, R.H.
16.	G10006	6	Hex Head Cap Screw, 5/8"-11 x 2 1/4"
	G10230	6	Lock Washer, 5/8"
	G10104	6	Hex Nut, 5/8"-11
17.	G10097	16	Hex Head Cap Screw, 3/4"-16 x 2 1/2"
	GD2169	16	Special Washer, 25/32" I.D. x 1 1/4" O.D., Hardened
	G10098	16	Hex Nut, 3/4"-16
18.	GD13328	4	Scraper
19.	G10017	8	Hex Head Cap Screw, 1/2"-13 x 1 1/2"
	G10206	8	Washer, 1/2" SAE
	G10228	8	Lock Washer, 1/2"

TRANSPORT WHEELS

(TWL198e)

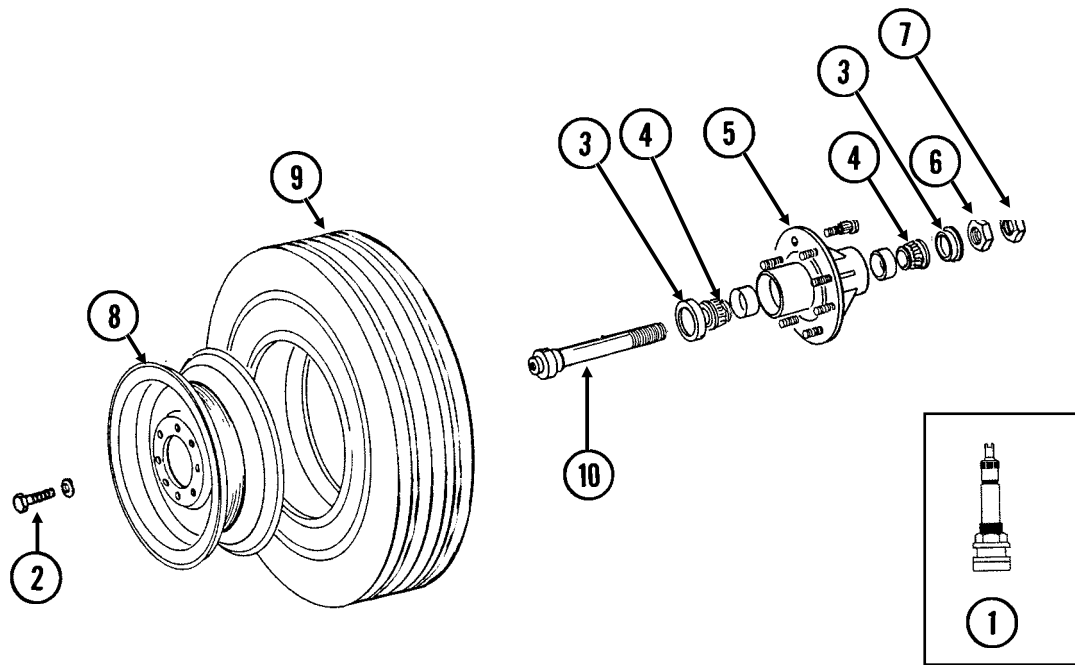

ITEM	PART NO.	QTY. (Per Assy.)	DESCRIPTION
1.	GA7434	-	Valve Stem
2.	G10448	2	Hex Head Cap Screw, 7/8"-9 x 2 1/2", Grade 8
	G10330	2	Lock Washer, 7/8"
3.	GA4722	2	Seal
4.	GA4723	2	Bearing
5.	GA4729	1	Hub W/Cups, Bolts, Nuts And Grease Fitting, 8 Bolt, 1 3/4" Bore
	G10640	-	Grease Fitting, 1/4"-28
	GD7079	-	Cup
	GR0528	-	Hub Bolt, 5/8"-18 x 2 1/4"
	GR0531	-	Lug Nut, 5/8"-18 UNF
6.	GD7089	1	Special Nut, 1 3/4"-12 UNF
7.	GD7864	1	Special Hex Nut, 1 3/4"-12 UNF
8.	GA9544	-	Rim, 5.5" x 22.5"
9.	GD15406	-	Tire, 41 x 11R22.5" W/O Center Rib (Specify Brand*)
10.	GA10139	1	Spindle W/Retaining Ring, 1 3/4"
	G10913	-	External Retaining Ring, 2 1/2"
A.	GA10553	-	Tire And Rim Assembly (Items 1, 8 And 9) (Specify Brand*)

* Specific brand requests will be supplied only as available from current KINZE® Repair Parts stock. If a specific brand requested is not in stock, the brand available will be supplied.

AXLE STEPS

(TWL242/TWL243)

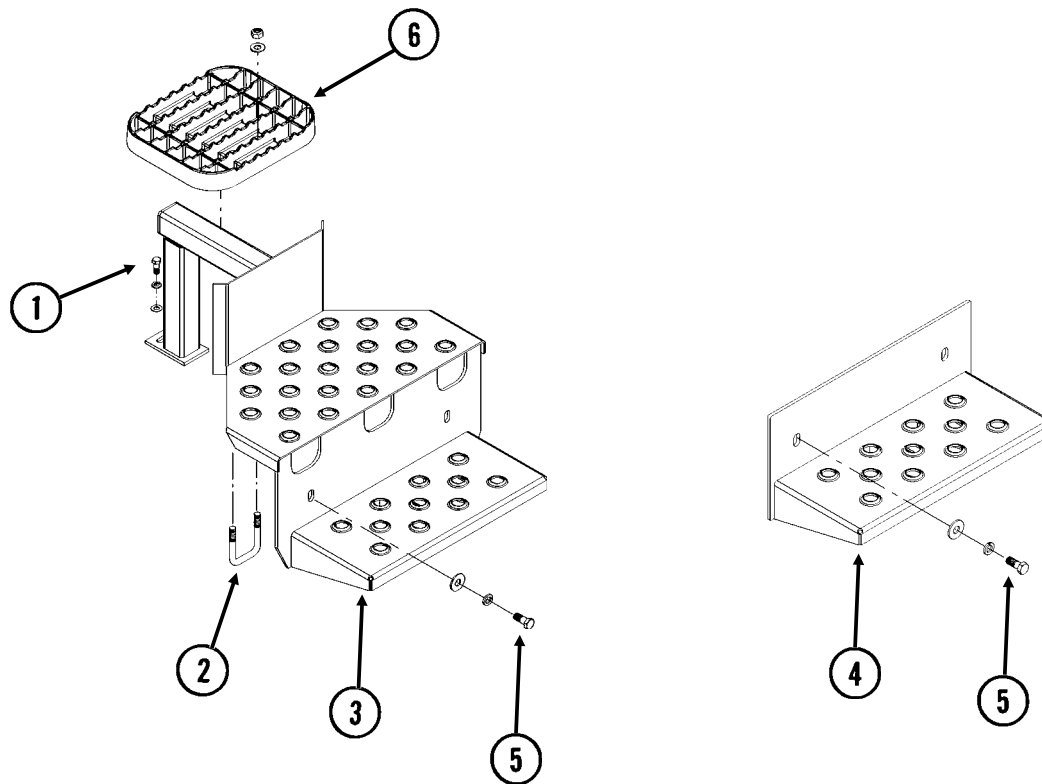

ITEM	PART NO.	QTY.	DESCRIPTION
1.	G10001	1	Hex Head Cap Screw, 3/8"-16 x 1" (SDS Only)
	G10210	1	Washer, 3/8" USS
	G10229	1	Lock Washer, 3/8"
2.	GD2721	2	U-Bolt, 2" x 2" x 1/2"-13 (SDS Only)
	G10206	4	Washer, 1/2" SAE
	G10111	4	Lock Nut, 1/2"-13
3.	GA9996	1	Axle Step (SDS Only)
4.	GA10131	1	Axle Step (Conventional Only)
5.	G10037	2	Hex Head Cap Screw, 1/2"-13 x 1 1/4"
	G10228	2	Lock Washer, 1/2"
	G10216	2	Washer, 1/2" USS
6.	GB0315	1	Step (SDS Only)

STABILIZER ASSEMBLY

(TWL244)

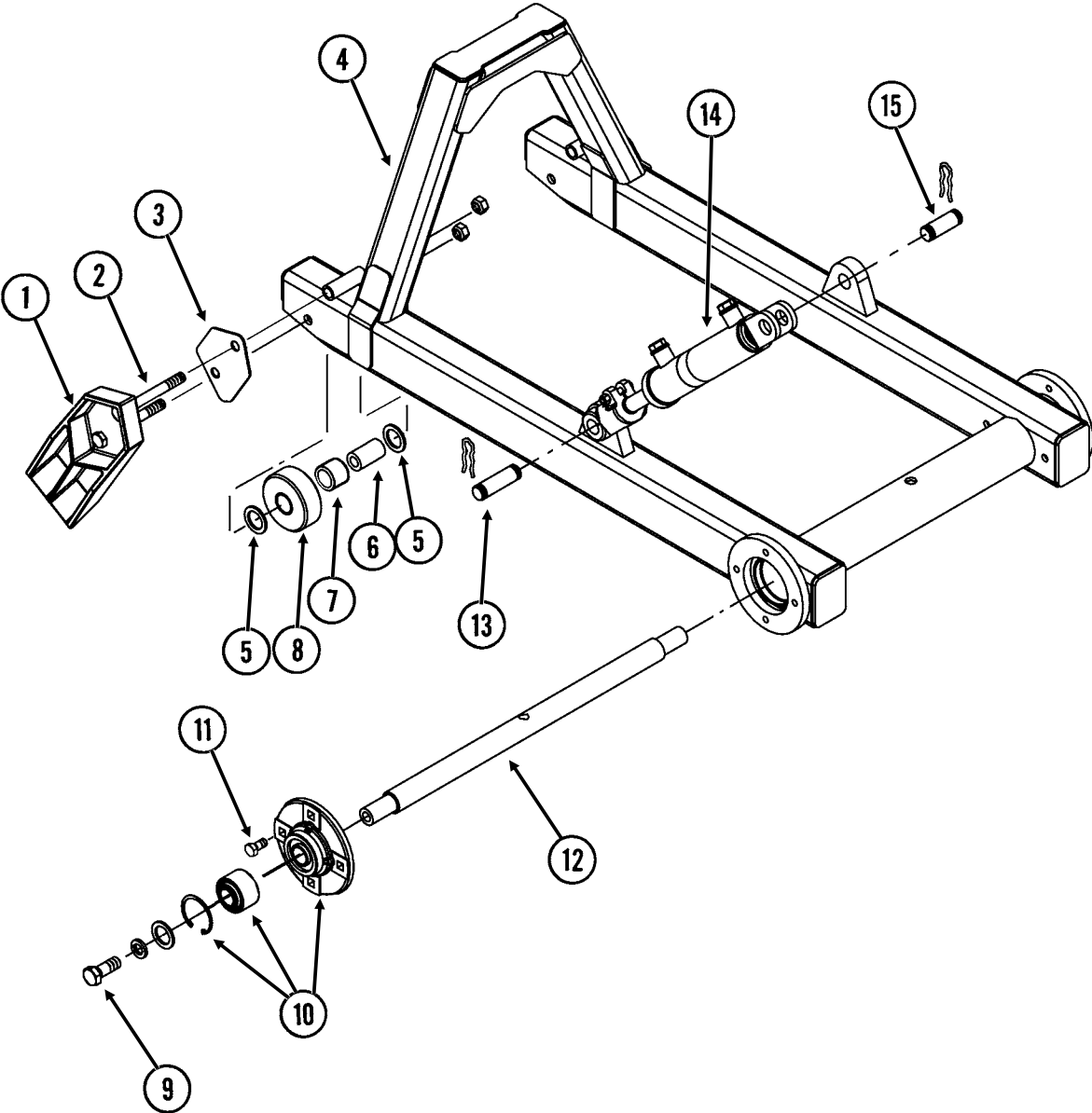

STABILIZER ASSEMBLY

ITEM	PART NO.	QTY.	DESCRIPTION
1.	GB0324	4	Guide Bar
2.	G10011	4	Hex Head Cap Screw, 5/8"-11 x 5 1/2"
	G10107	4	Lock Nut, 5/8"-11
3.	GD14350	-	Shim (As Required)
4.	GA9999	1	Stabilizer
5.	G10159	8	Machine Bushing, 1 1/4", 10 Gauge
6.	GD14327	2	Sleeve, 1 1/4" x 2 15/22"
7.	GD14363	2	Bronze Bushing, 1 1/2" O.D. x 1 1/4" I.D. x 1 1/2" Long
8.	GD14328	2	Roller
9.	G10026	2	Hex Head Cap Screw, 3/4"-10 x 2"
	G10231	2	Lock Washer, 3/4"
	G10159	2	Machine Bushing, 1 1/4", 10 Gauge
10.	GA8641	1	Hub W/Bearing And Retaining Ring
	GA8603	-	Double Row Bearing
	GD11652	-	Retaining Ring, 2 7/16"
11.	G10014	8	Hex Head Cap Screw, 1/2"-13 x 1"
12.	GD14341	1	Shaft, 1 1/2" x 28 7/16"
13.	GR0375	2	Pin, 1" x 3 1/2"
	GR0193	4	Hair Pin Clip
14.		-	See "Stabilizer Cylinder", Page P92
15.	GR0367	2	Pin, 1" x 2 7/8"
	GR0193	4	Hair Pin Clip

HOSE TAKE-UP

PHA039(TWL137b)

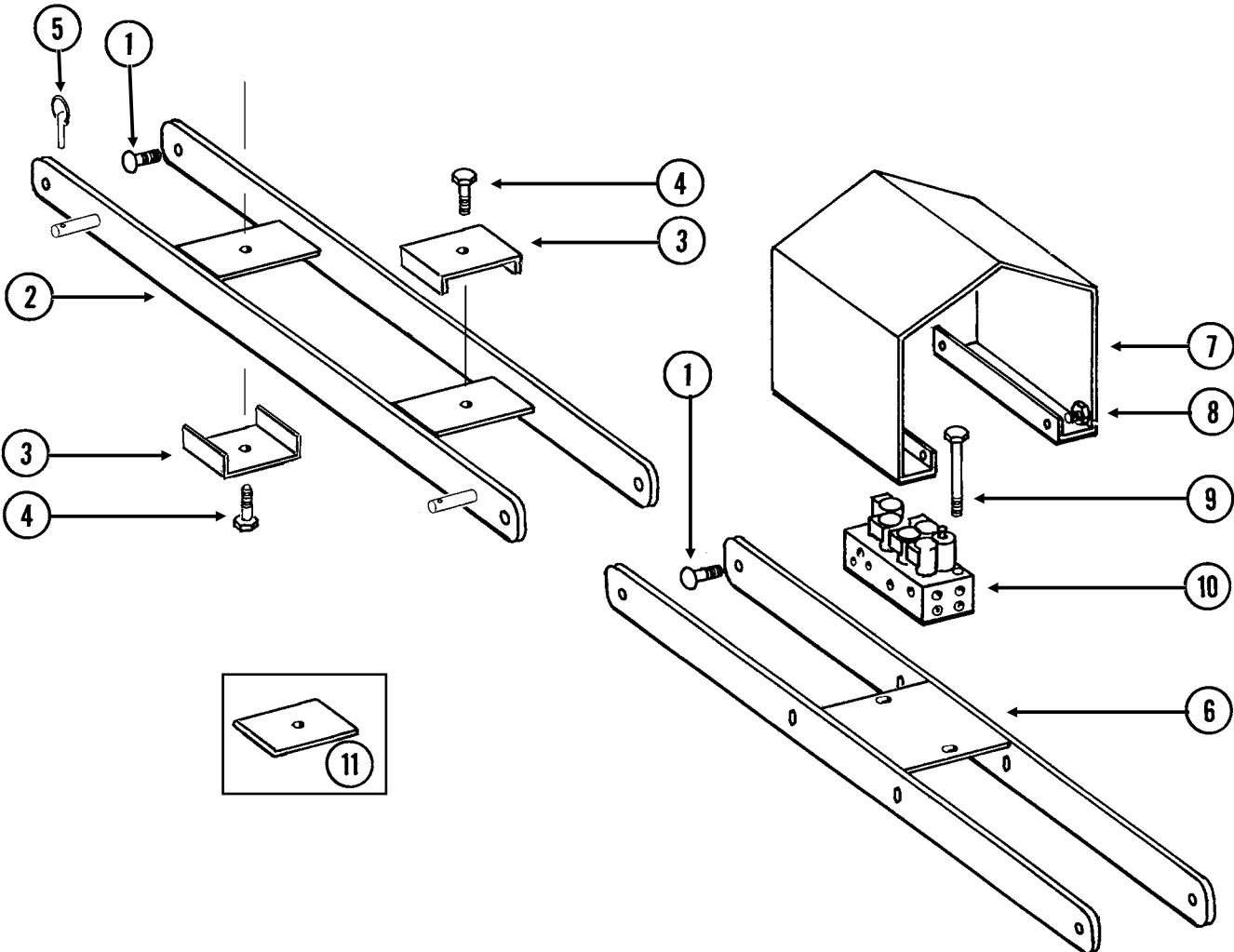

HOSE TAKE-UP

ITEM	PART NO.	QTY.	DESCRIPTION
1.	G10689	6	Carriage Bolt, 5/8"-11 x 2"
	GB0218	6	Bushing, 2 1/32" I.D. x 7/8" O.D. x 1 9/32" Long
	GD7805	6	Special Washer, 5/8", Hardened
	G10107	6	Lock Nut, 5/8"-11
2.	GA10090	-	Take-Up, 44 1/4", 12 Row 30" (Shown)
	GA10112	-	Take-Up, 56 1/4", 16 Row 30"
3.	GD8188	2	Clamp, 7/8" x 3" x 5 3/8"
	GD8189	2	Rubber Pad
4.	G10581	1	Hex Head Cap Screw, 1/2"-13 x 2 1/4"
	G10111	1	Lock Nut, 1/2"-13
5.	GD2558	2	Lynch Pin, 1/4"
6.	GA7021	-	Take-Up, 44 1/4", 12 Row 30" (Shown)
	GA7050	-	Take-Up, 56 1/4", 16 Row 30"
7.	GD9952	1	Cover
8.	G10004	4	Hex Head Cap Screw, 3/8"-16 x 1 1/4"
	G10229	4	Lock Washer, 3/8"
	G10203	8	Washer, 3/8" SAE
	G10101	4	Hex Nut, 3/8"-16
9.	G10172	2	Hex Head Cap Screw, 3/8"-16 x 5"
	G10210	2	Washer, 3/8" USS
	G10108	2	Lock Nut, 3/8"-16
10.			See "Valve Block - Located On Hitch", Page P106
11.	GD18776	1	Clamp, 4" x 4 3/8"

CENTER FRAME

(TWL277)

12 ROW 30" SHOWN

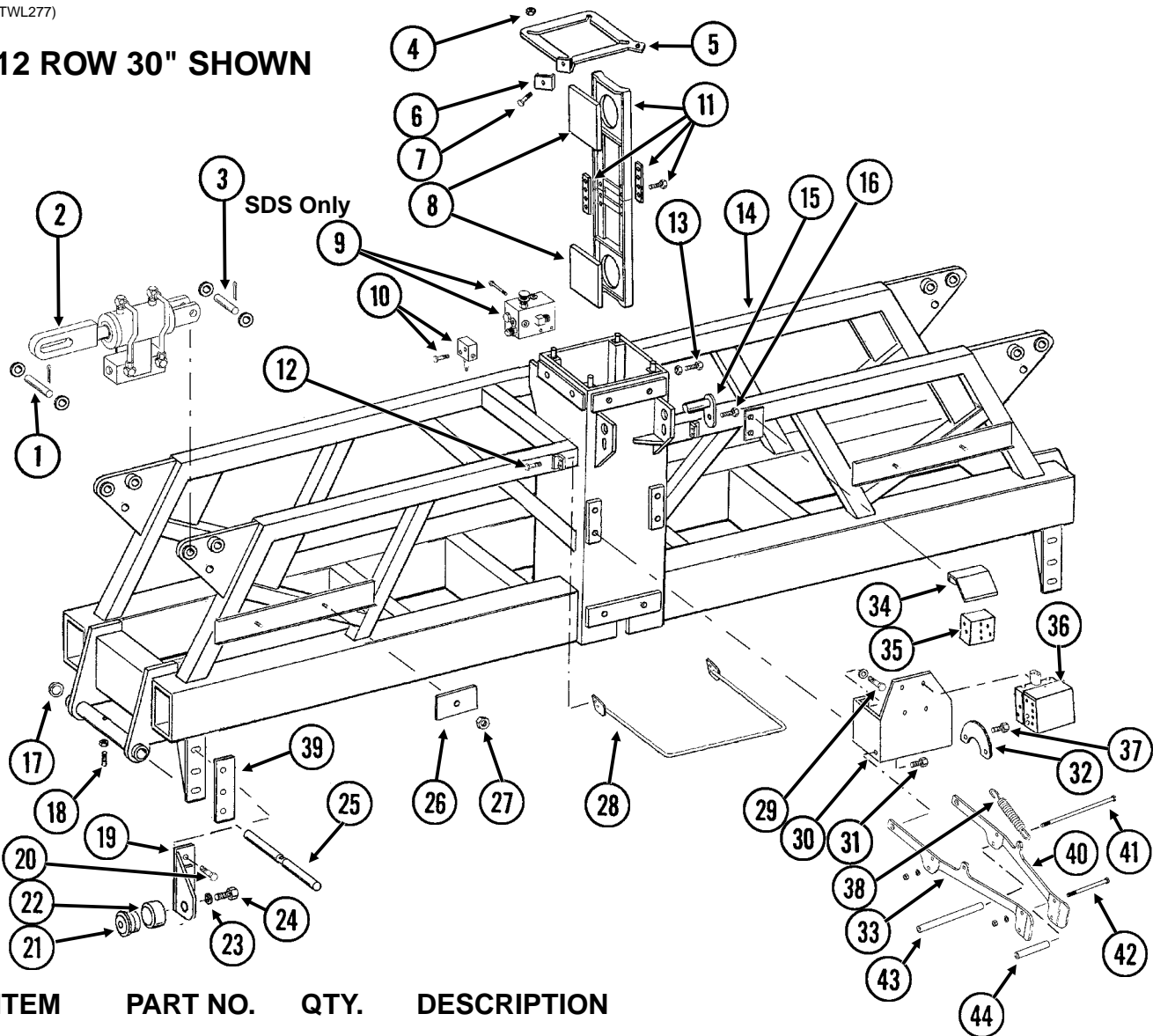

ITEM	PART NO.	QTY.	DESCRIPTION
1.		-	See "Wing Frame", Pages P68 And P69
2.		-	See "Wing Lock Cylinders", Pages P96 And P97
3.	GD0535	2	Pin, 1 1/4" x 4 1/2"
	G10159	4	Machine Bushing, 1 1/4", 10 Gauge
	G10460	4	Cotter Pin, 1/4" x 2"
4.	GD7805	4	Special Washer, 5/8", Hardened
	G10104	4	Hex Nut, 5/8"-11
5.	GD14093	1	Cap
6.	GD5875	1	Hose Clamp, 9/16" x 2 1/2" x 2"
7.	G10048	1	Hex Head Cap Screw, 3/8"-16 x 2"
	G10108	1	Lock Nut, 3/8"-16
8.	GD10053	8	Wear Pad, 7" x 7" x 1/2" Thick
9.		-	See "Valve Block - Located On Front Center Frame", Page P101
10.		-	See "Valve Block - Located On Front Center Frame", Page P102
11.	GA7579	4	Pad Holder W/Bars
	GD10706	-	Bar, 1 1/4" x 6" x 1/4" Thick
	GD10707	-	Bar, 1 1/4" x 6" x 3/8" Thick
	G10001	-	Hex Head Cap Screw, 3/8"-16 x 1"
12.	G10004	4	Hex Head Cap Screw, 3/8"-16 x 1 1/4"
	G10229	4	Lock Washer, 3/8"
	G10101	4	Hex Nut, 3/8"-16

CENTER FRAME

ITEM	PART NO.	QTY.	DESCRIPTION
13.	G10543	16	Hex Head Cap Screw, 3/4"-10 x 3", Full Thread
	G10105	16	Hex Nut, 3/4"-10
14.	A10089	-	Frame, 136", 12 Row 30" And 16 Row 30" (Non-Stock Item)
15.	GA5121	4	Pin, 2 1/8"
16.	G10636	4	Carriage Bolt, 1/2"-13 x 1 1/2"
	G10228	4	Lock Washer, 1/2"
	G10102	4	Hex Nut, 1/2"-13
17.	G10404	-	Machine Bushing, 3 1/8" x 2 1/8" x 3/16" (As Required)
	G10234	-	Machine Bushing, 2 1/8", 10 Gauge (As Required)
	G10336	-	Machine Bushing, 2 1/8", 14 Gauge (As Required)
18.	G10828	2	Hex Socket Set Screw, 1/2"-13 x 1 1/4"
	G10527	2	Lock Washer, 1/2", Internal/External
	G10102	2	Hex Nut, 1/2"-13
19.	GA10073	1	Cam Roller Mount, L.H. (Shown)
	GA10072	-	Cam Roller Mount, R.H.
20.	G11084	6	Carriage Bolt, 5/8"-11 x 1 3/4"
	G10230	6	Lock Washer, 5/8"
	G10104	6	Hex Nut, 5/8"-11
21.	GA6497	4	Cam Follower W/Grease Fitting
	G10640	-	Grease Fitting, 1/4"-28
22.	GD14066	4	Sleeve
23.	GB0409	2	Spring Washer
24.	G10025	2	Hex Head Cap Screw, 3/4"-10 x 1 1/2"
25.	GD10531	2	Hinge Pin, 2 1/8" x 25 3/4"
26.	GD13154	4	Hose Clamp, 4 3/4" x 9"
27.	G10108	4	Lock Nut, 3/8"-16
28.	GA10104	1	Handle (SDS Only)
29.	G10014	4	Hex Head Cap Screw, 1/2"-13 x 1"
	G10216	4	Washer, 1/2" USS
	G10228	4	Lock Washer, 1/2"
30.	GD12774	1	Mount
31.	G11125	2	Carriage Bolt, 5/8"-11 x 1 3/4"
	GB0218	2	Bushing, 2 1/32" I.D. x 7/8" O.D. x 1 9/32" Long
	GD7805	2	Special Washer, 5/8", Hardened
	G10107	2	Lock Nut, 5/8"-11
32.	GD13107	1	Spring Pivot
33.	GD16414	1	Hose Holder, R.H.
34.	GD14102	1	Cover
35.		-	See "Valve Block - Located On R.H. Side Of Center Pivot", Page P103
36.		-	See "Valve Blocks - Located On Rear Center Frame", Pages P104 And P105
37.	G10004	1	Hex Head Cap Screw, 3/8"-16 x 1 1/4"
	G10203	1	Washer, 3/8" SAE
	GD8893-03	1	Sleeve, 1 3/8" Long
	G10108	1	Lock Nut, 3/8"-16
38.	GD8249	1	Spring
	GD7904-02	2	Sleeve, 1/2" x 1/2" Long
39.	GD15806	-	Shim, 3 3/4" x 10", 7 Gauge
	GD15807	-	Shim, 3 3/4" x 10" x 1/4" Thick
40.	GD16415	1	Hose Holder, L.H.
41.	G11177	2	Hex Head Cap Screw, 1/2"-13 x 14"
	G10228	2	Lock Washer, 1/2"
	G10102	2	Hex Nut, 1/2"-13
42.	G11109	2	Hex Head Cap Screw, 1/2"-13 x 7 1/2"
	G10228	2	Lock Washer, 1/2"
	G10102	2	Hex Nut, 1/2"-13
43.	GD4887-08	2	Sleeve, 1/2" I.D. x 12 1/4" Long
44.	GD4887-09	2	Sleeve, 1/2" I.D. x 6" Long

WING FRAME

(TWL187c/TWL180a/TWL194h/TWL194g/TWL194e/TWL188b/TWL139b)

12 ROW 30" SHOWN

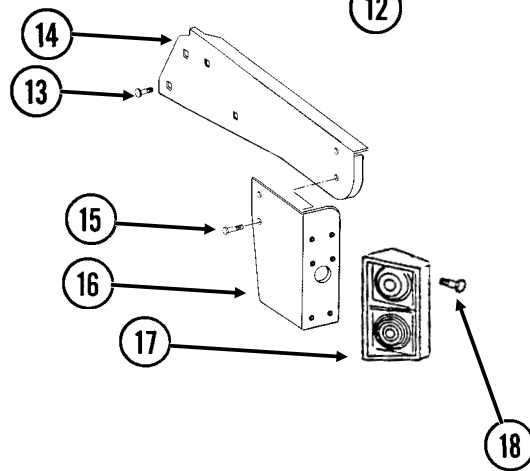
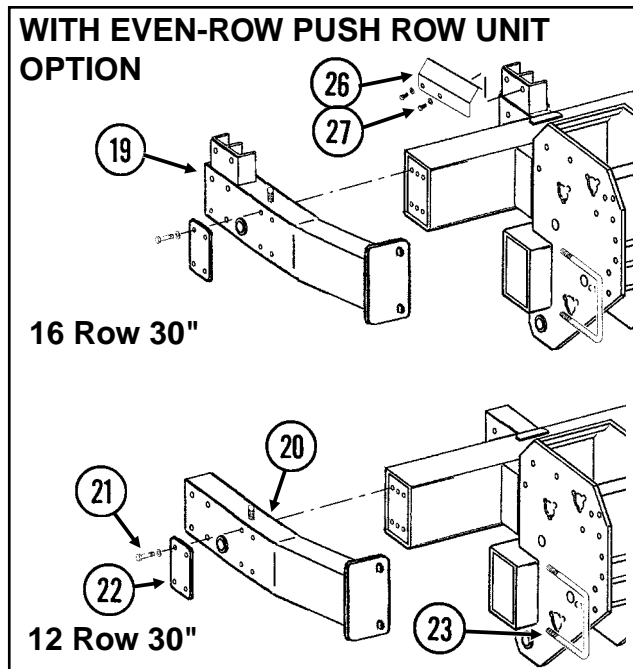
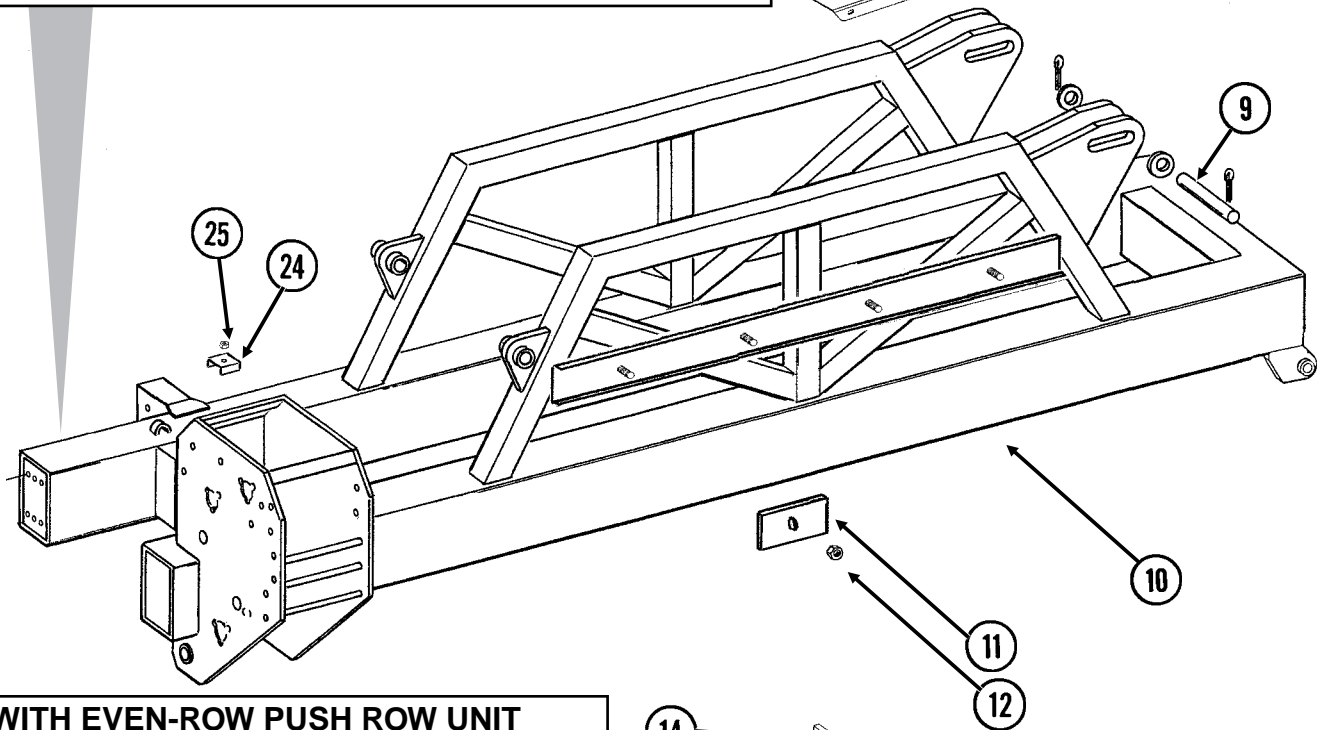
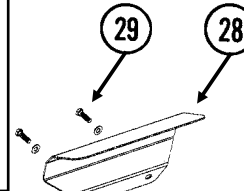
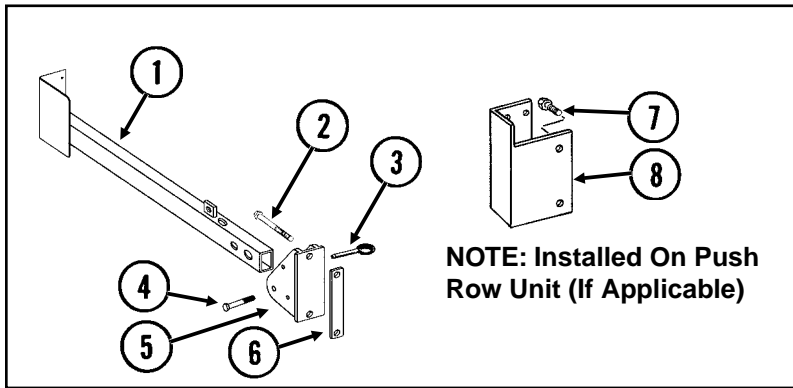

WING FRAME

ITEM	PART NO.	QTY.	DESCRIPTION
1.	GA9840	1	Light Bracket
2.	G10439	2	Hex Head Cap Screw, 5/8"-11 x 7"
	G10230	2	Lock Washer, 5/8"
	G10104	2	Hex Nut, 5/8"-11
3.	G10874	1	Detent Pin, 1/2" x 3 1/2" Grip
4.	G10033	1	Hex Head Cap Screw, 1/2"-13 x 3 1/2"
	G10206	4	Washer, 1/2" SAE
	G10111	1	Lock Nut, 1/2"-13
5.	GB0309	1	Light Mount Bracket
6.	GD1908	1	Mounting Bracket
7.	G10001	2	Hex Head Cap Screw, 3/8"-16 x 1"
	G10229	2	Lock Washer, 3/8"
	G10101	2	Hex Nut, 3/8"-16
8.	GD12703	1	Push Row Unit Light Bracket
9.	GD0826	4	Pin, 1 1/4" x 5 1/2"
	GD0752-47	8	Sleeve, 1/2"
	G10159	8	Machine Bushing, 1 1/4", 10 Gauge
	G10460	8	Cotter Pin, 1/4" x 2"
10.	A9070	-	Wing, R.H., 120", 12 Row 30" (Non-Stock Item)
	A9069	-	Wing, L.H., 124", 12 Row 30" (Non-Stock Item)
	A9072	-	Wing, R.H., 180", 16 Row 30" (Non-Stock Item)
	A9073	-	Wing, L.H., 184", 16 Row 30" (Non-Stock Item)
11.	GD13153	8-10	Hose Clamp, 3 1/4" x 9"
12.	G10108	8-10	Lock Nut, 3/8"-16
13.	G10312	3	Carriage Bolt, 5/16"-18 x 3/4"
	G10620	3	Serrated Flange Nut, 5/16"-18
14.	GD15950	1	Light Mount Extension
15.	G10064	-	Hex Head Cap Screw, 1/4"-20 x 1"
	G10227	-	Lock Washer, 1/4"
	G10103	-	Hex Nut, 1/4"-20
16.	GD12724	1	Bracket
17.			See "Electrical Components", Pages P116-P119
18.	G10064	-	Hex Head Cap Screw, 1/4"-20 x 1"
	G10110	-	Lock Nut, 1/4"-20, Grade B
19.	GA9903	1	Marker Mount, 16 Row 30"
20.	GA9902	1	Marker Mount, 12 Row 30"
21.	G10050	4	Hex Head Cap Screw, 3/4"-10 x 5"
	G10231	4	Lock Washer, 3/4"
22.	GD14163	1	Plate
23.	GD1113	1	U-Bolt, 5" x 7" x 5/8"-11
	G10230	2	Lock Washer, 5/8"
	G10104	2	Hex Nut, 5/8"-11
24.	GD5875	5	Hose Clamp, 3/16" x 2 1/2" x 2"
25.	G10108	5	Lock Nut, 3/8"-16
26.	GD15567	1	Shield
27.	G10007	2	Hex Head Cap Screw, 5/8"-11 x 1 1/2"
	G10217	2	Washer, 5/8" USS
	G10230	2	Lock Washer, 5/8"
	G10104	2	Hex Nut, 5/8"-11
28.	GD15574	2	Shield
29.	G10004	4	Hex Head Cap Screw, 3/8"-16 x 1 1/4"
	G10210	4	Washer, 3/8" USS
	G10229	4	Lock Washer, 3/8"
	G10101	4	Hex Nut, 3/8"-16
A.	G7698X	-	Push Row Unit Mounted Light Bracket Package (Items 7 And 8 On This Page And 3/8" Insulated Clamp, Item 6 On Pages P118 And P119 Or Item 6 On Pages P120 And P121)

CENTER PIVOT

PFA087(TWL196b)

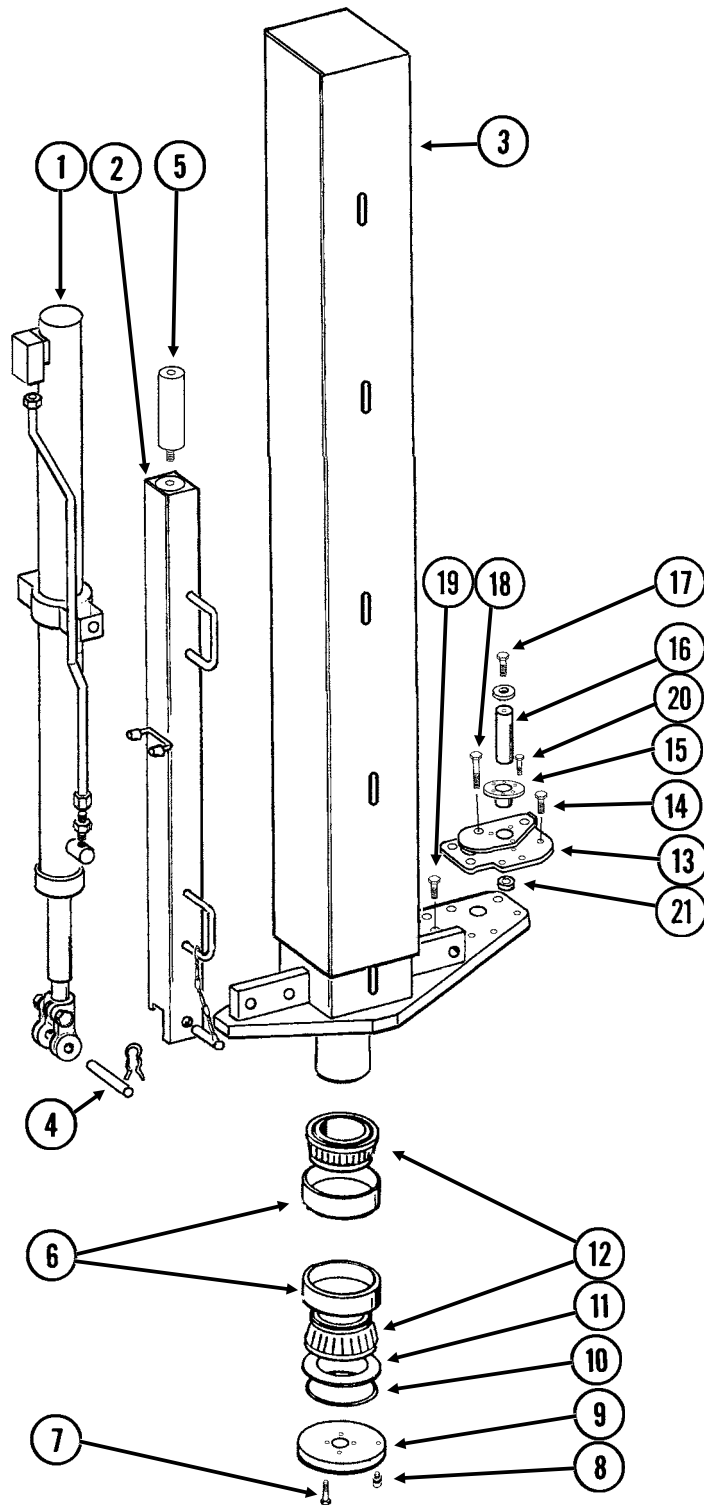

CENTER PIVOT

ITEM	PART NO.	QTY.	DESCRIPTION
1.		-	See "Center Lift Cylinder", Pages P93 Or P94
2.	GA10092	1	Manual Safety Lockup W/Detent Pin, 42 7/8" Long
	GA7022	-	Detent Pin W/Chain
3.	GA10085	1	Center Post, 97 3/16"
4.	GR0375	2	Pin, 1" x 3 1/2"
	GR0193	4	Hair Pin Clip
5.	GD14507	1	Lockup Extension, 10"
6.	GD10011	2	Cup
7.	G10027	4	Hex Head Cap Screw, 3/4"-10 x 2 1/2"
	GD2169	4	Special Washer, 25/32" I.D. x 1 1/4" O.D., Hardened
8.	G10640	1	Grease Fitting, 1/4"-28
9.	GD13338	1	Bearing Cap
10.	GD13350	1	O-Ring Seal
11.	GD10012	10	Shim, .005" Thick (As Required)
	GD10013	10	Shim, .020" Thick (As Required)
	GD10014	10	Shim, .007" Thick (As Required)
12.	GA7096	2	Cone
13.	GA9618	1	Taper Lock Mount
14.	G11018	3	Hex Head Cap Screw, 5/8"-18 x 1 1/4"
	GD7805	3	Special Washer, 5/8", Hardened
15.	GD13519	1	Taper Lock Collar
16.	GD13520	1	Taper Lock Pin
17.	G10443	1	Hex Head Cap Screw, 5/8"-11 x 1"
	G10205	1	Washer, 5/8" SAE
18.	G11019	2	Hex Head Cap Screw, 5/8"-18 x 5"
	GD7805	2	Special Washer, 5/8", Hardened
19.	G10751	2	Hex Head Cap Screw, 5/8"-18 x 1 3/4"
	GD7805	2	Special Washer, 5/8", Hardened
20.	G10004	3	Hex Head Cap Screw, 3/8"-16 x 1 1/4"
21.	GD13525	1	Tension Bushing, 1 1/2" O.D. x 1 1/4" I.D. x 5/8" Long

CONTACT DRIVE WHEEL AND DRIVE SHAFT(S)

PTD057/PFA046/PTD075/PLA033(TWL11p)

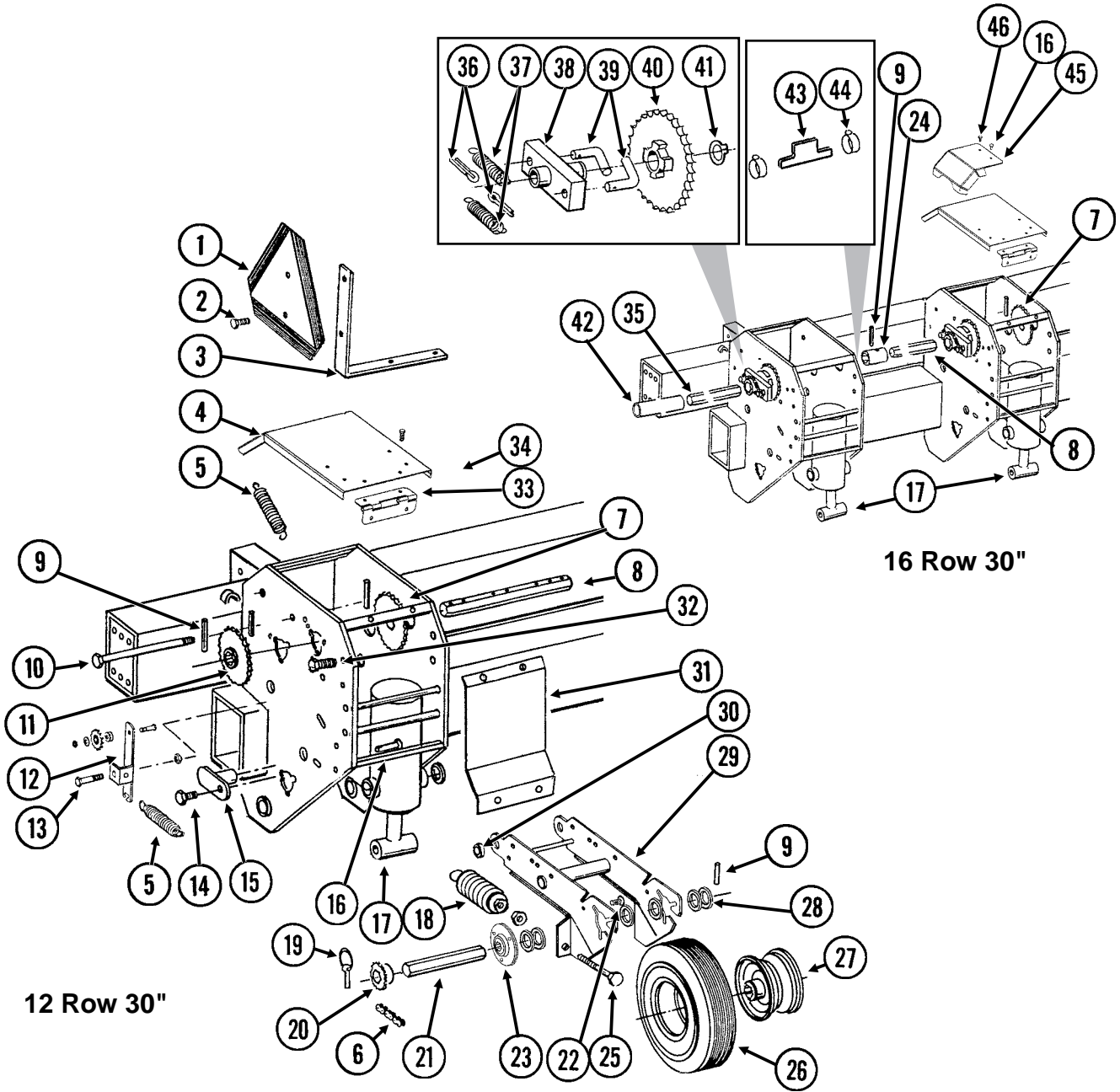

CONTACT DRIVE WHEEL AND DRIVE SHAFT(S)

ITEM	PART NO.	QTY.	DESCRIPTION
		(Per Assy.)	
1.	GD2199	1	SMV Sign
2.	G10022	2	Hex Head Cap Screw, 1/4"-20 x 1/2"
	G10227	2	Lock Washer, 1/4"
	G10103	2	Hex Nut, 1/4"-20
3.	GD9969	1	Bracket
4.	GD10298	1	Cover
5.	GD5857	2	Spring
6.	G3310-114	1	Chain, No. 40, 114 Pitch Including Connector Link (Used With 22 Tooth Sprocket)
	G3310-118	-	Chain, No. 40, 118 Pitch Including Connector Link (Used With 28 Tooth Sprocket)
	G3310-126	-	Chain, No. 40, 126 Pitch Including Connector Link (Used With 44 Tooth Sprocket)
	GR0912	-	Connector Link, No. 40
7.		-	See "Inner Module Drive", Pages P78 And P79
8.		-	See "Point Row Clutch", Pages P80 And P81
9.	G10602	4	Spring Pin, 1/4" x 1 1/2"
10.	G10595	-	Hex Head Cap Screw, 3/8"-16 x 10" (Used To Secure Point Row Clutch)
	G10108	-	Lock Nut, 3/8"-16
11.	GA5114	1	Sprocket, 30 Tooth
12.	GA9553	1	Idler W/Sprocket And Hardware, L.H.
	GA9554	1	Idler W/Sprocket And Hardware, R.H. (Shown)
	GA7154	-	Sprocket W/Bearing, 18 Tooth
	G10017	-	Hex Head Cap Screw, 1/2"-13 x 1 1/2"
	G10128	-	Machine Bushing, 1/2", 14 Gauge
	G10501	-	Hex Jam Nut, 1/2"-13, Grade 2
13.	G10036	1	Hex Head Cap Screw, 5/8"-11 x 4"
	G10918	3	Machine Bushing, 5/8", 14 Gauge
	G10104	1	Hex Nut, 5/8"-11
	G10107	1	Lock Nut, 5/8"-11
14.	G10017	2	Hex Head Cap Screw, 1/2"-13 x 1 1/2"
	G10216	2	Washer, 1/2" USS
	G10228	2	Lock Washer, 1/2"
	G10102	2	Hex Nut, 1/2"-13
15.	GA5121	2	Pin, 2 1/8"
16.	G10870	2	Clevis Pin, 3/8" x 1"
	G10860	2	Retaining Ring, 3/8"
17.		-	See "Wing Lift Cylinder", Page P95
18.	GA2068	2	Spring W/Plug
19.	GD2558	1	Lynch Pin, 1/4"
20.	GA12192	1	Sprocket, 22 Tooth
	GA5113	1	Sprocket, 28 Tooth
	GA12191	-	Sprocket, 44 Tooth
21.	GD6775	1	Hex Shaft, 7/8" x 11 3/4" (2 Holes)
22.	G10303	6	Carriage Bolt, 5/16"-18 x 1"
	G10232	6	Lock Washer, 5/16"
	G10106	6	Hex Nut, 5/16"-18
23.	GA9846	-	Flanged Bearing, 7/8" Hex Bore
24.	GD5212	1	Coupler, 1 3/4", 16 Row 30" Only
25.	G10890	2	Hex Head Adjusting Bolt, 1/2"-13 x 4", Grade 2
	G10501	2	Hex Jam Nut, 1/2"-13, Grade 2
26.	GD4700	1	Tire, 4.80" x 8", 4 Ply, Rib Implement (Specify Brand*)
	GD4701	-	Valve Stem
27.	GA3553	1	Rim, 3.75" x 8"
28.	G10233	-	Machine Bushing, 1", 10 Gauge

(Continued)

CONTACT DRIVE WHEEL AND DRIVE SHAFT(S)

ITEM	PART NO.	QTY. (Per Assy.)	DESCRIPTION
(Continued)			
29.	GA7372	1	Wheel Arm
30.	GB0218	2	Bushing, 2 ¹ / ₃₂ " I.D. x 7 ⁷ / ₈ " O.D. x 1 ⁹ / ₃₂ " Long
31.	GD6895	1	Shield
32.	G10008	2	Hex Head Cap Screw, 5 ⁸ / ₁₆ "-11 x 2"
	G10235	4	Machine Bushing, 7 ⁸ / ₁₆ ", 14 Gauge
	GD7805	2	Special Washer, 5 ⁸ / ₁₆ ", Hardened
	G10205	2	Washer, 5 ⁸ / ₁₆ " SAE
	G10107	2	Lock Nut, 5 ⁸ / ₁₆ "-11
33.	GD5789	1	Hinge, Female
	GD5790	1	Hinge W/Pins, Male
34.	G10064	6	Hex Head Cap Screw, 1 ¹ / ₄ "-20 x 1"
	G10227	6	Lock Washer, 1 ¹ / ₄ "
	G10103	6	Hex Nut, 1 ¹ / ₄ "-20
35.	GD10099	-	Hex Shaft, 7 ⁸ / ₁₆ " x 29 5 ⁸ / ₁₆ "
36.	G10453	2	Cotter Pin, 3 ¹⁶ / ₁₆ " x 1"
37.	GD1256	2	Spring
38.	GA0378	1	Block And Hub Assembly
39.	GD1255	2	L-Pin
40.	GA5165	1	Sprocket, 30 Tooth
41.	G10430	1	External Retaining Ring, 1 1 ¹ / ₄ "
42.	GD13652-01	1	Pipe, 1" x 23 1 ¹ / ₄ "
43.	GD14115	1	Catch
44.	G10278	2	Hose Clamp, No. 16
45.	GD16465	1	Cover
46.	G10020	1	Hex Head Cap Screw, 1 ¹ / ₄ "-20 x 5 ⁸ / ₁₆ "
	G10227	1	Lock Washer, 1 ¹ / ₄ "
	G10103	1	Hex Nut, 1 ¹ / ₄ "-20
A.	GA3552	-	Tire And Rim Assembly (Items 26 And 27) (Specify Brand*)
B.	GA9843	-	Ratchet/Sprocket Assembly (L.H. Side Of Planter) (Items 36-41)
	GA5164	-	Ratchet/Sprocket Assembly (R.H. Side Of Planter) (Items 36-41)
C.	G1K324	-	Contact Wheel Arm Replacement Kit (Items 9, 21, 22, 23, 25, 28 And 29)

* Specific brand requests will be supplied only as available from current KINZE® Repair Parts stock. If a specific brand requested is not in stock, the brand available will be supplied. Different brand tires may have different diameters. Change in tire brand may affect rates. Field checks are recommended after any change in contact tires.

GROUND DRIVE WHEEL

PTD057(TWL142b)

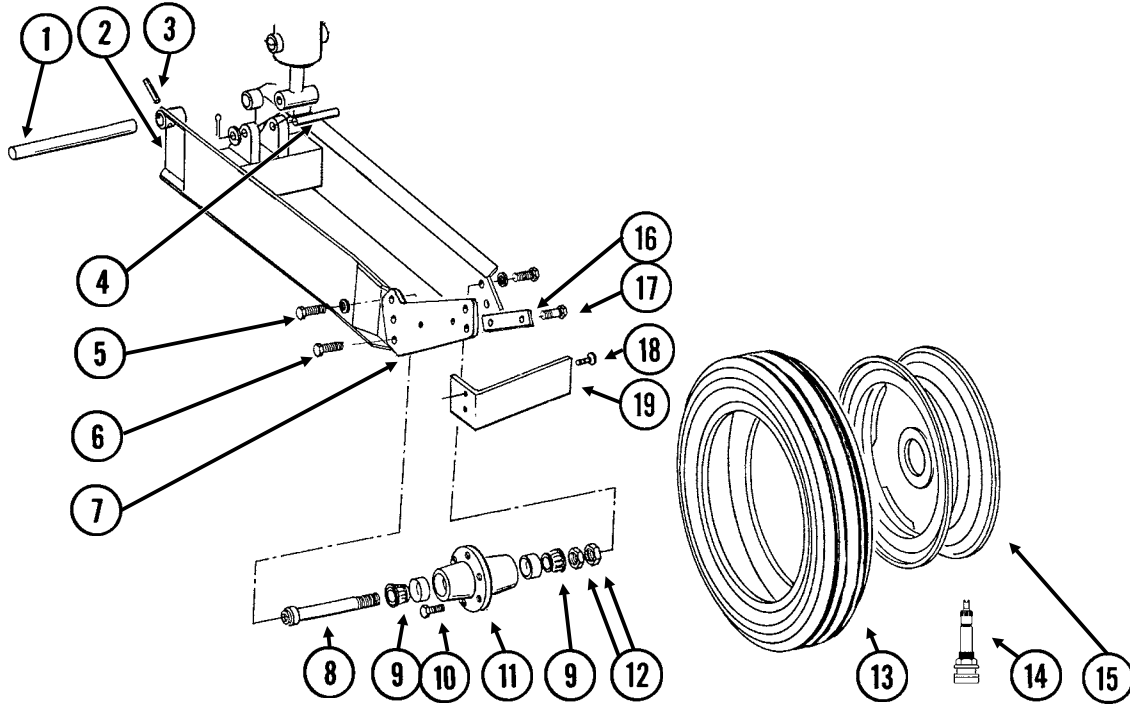

ITEM	PART NO.	QTY. (Per Assy.)	DESCRIPTION
1.	GD11695	-	Pin, 1 1/4" x 13 1/4"
2.	GA8677	1	Wheel Module
3.	G10610	-	Spring Pin, 3/8" x 2"
4.	GD5841	1	Pin, 1 1/4" x 5 5/8"
	G10226	2	Washer, 1 1/4" SAE
	G10460	2	Cotter Pin, 1/4" x 2"
5.	G10026	2	Hex Head Cap Screw, 3/4"-10 x 2"
	G10231	2	Lock Washer, 3/4"
6.	G10026	2	Hex Head Cap Screw, 3/4"-10 x 2"
	G10231	2	Lock Washer, 3/4"
	G10105	2	Hex Nut, 3/4"-10
7.	GD10128	1	Scraper Arm
8.	GA4376	1	Spindle W/Round External Retaining Ring, 10"
	GD11490	-	Round External Retaining Ring
9.	GA0895	2	Bearing
10.	GR0270	6	Lug Bolt, 9/16"-18
11.	GA2148	1	Hub W/Cups, 6 Bolt
	GR0434	-	Cup
12.	G11081	2	Hex Jam Nut, 1 1/2"-12, Grade 2
13.	GD13401	1	Tire, 7.50" x 20", 8 Ply, Tubeless W/O Center Rib (Specify Brand*)
14.	GA7434	-	Valve Stem
15.	GA2908	1	Rim, 5.5" x 20"
16.	GD10144	1	Bar Clamp
17.	G10039	2	Hex Head Cap Screw, 1/2"-13 x 1 3/4"
	G10228	2	Lock Washer, 1/2"
	G10102	2	Hex Nut, 1/2"-13
18.	G10636	2	Carriage Bolt, 1/2"-13 x 1 1/2"
	G10216	2	Washer, 1/2" USS
	G10228	2	Lock Washer, 1/2"
	G10102	2	Hex Nut, 1/2"-13
19.	GD12543	1	Scraper
A.	GA7997	-	Tire And Rim Assembly (Specify Brand*)(Items 13-15)
B.	GA4377	-	Hub And Spindle Assembly (Items 8, 9, 11 And 12)

* Specific brand requests will be supplied only as available from current KINZE® Repair Parts stock. If a specific brand requested is not in stock, the brand available will be supplied.

SEED RATE TRANSMISSION AND ROW UNIT DRILL SHAFTS

(TWL14jj)

12 Row 30" Shown

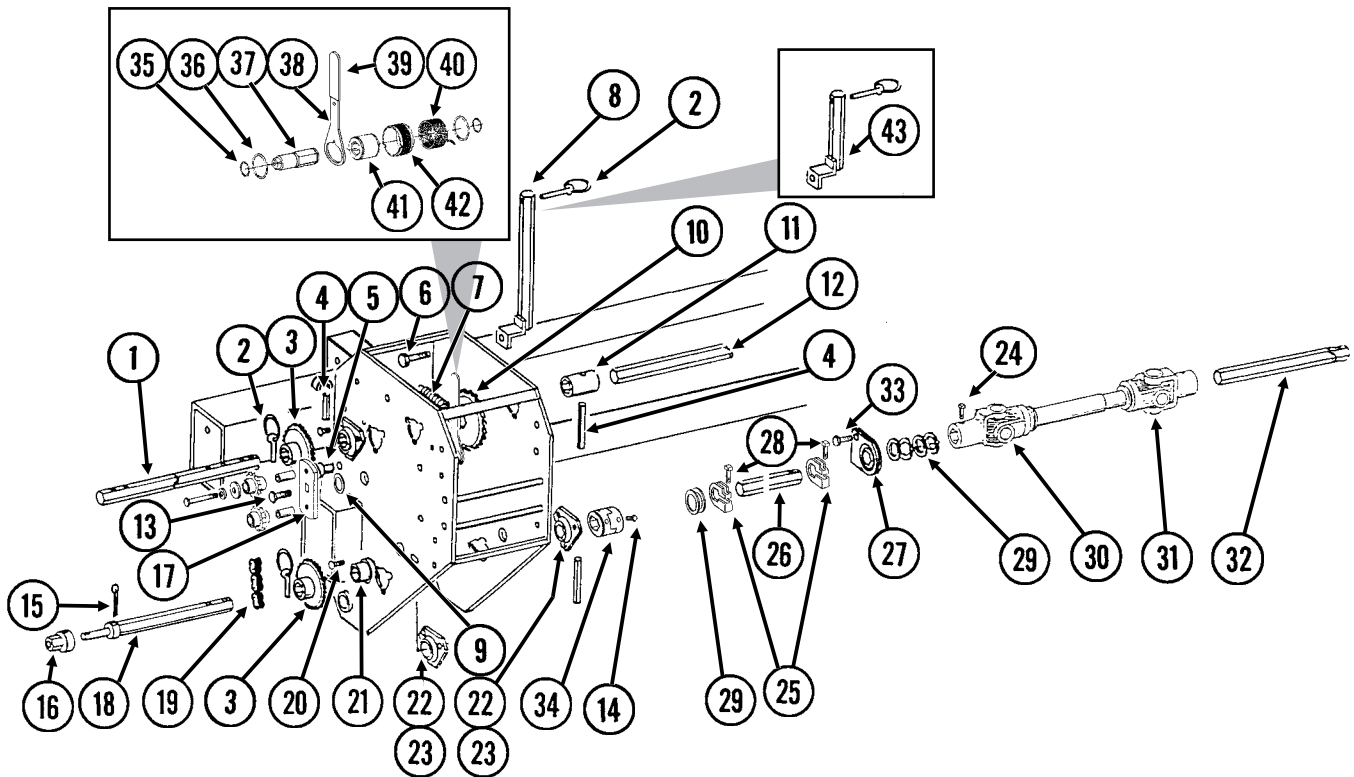

ITEM	PART NO.	QTY. (Per Side)	DESCRIPTION
1.	GD6780	1	Shaft, 7/8" x 15"
2.	GD2558	3	Lynch Pin, 1/4"
3.	GA5105	1	Sprocket, 15 Tooth
	GA5106	1	Sprocket, 17 Tooth
	GA5107	2	Sprocket, 19 Tooth
	GA5108	2	Sprocket, 23 Tooth
	GA5109	1	Sprocket, 24 Tooth
	GA5110	1	Sprocket, 25 Tooth
	GA5111	1	Sprocket, 26 Tooth
	GA5112	1	Sprocket, 27 Tooth
	GA5113	1	Sprocket, 28 Tooth
4.	G10602	-	Spring Pin, 1/4" x 1 1/2"
5.	G10870	1	Clevis Pin, 3/8" x 1"
	G10860	1	Retaining Ring, 3/8"
6.	G10016	1	Hex Head Cap Screw, 1/2"-13 x 2"
	GD10356	1	Bushing, 3/4" Long (If Applicable)
	G10228	1	Lock Washer, 1/2"
	G10527	2	Lock Washer, 1/2", Internal/External
	G10102	1	Hex Nut, 1/2"-13
7.	GD5857	1	Spring
8.	GA10832	1	Sprocket Storage Rod
9.	G10235	1	Machine Bushing, 7/8", 14 Gauge
10.		-	See "Inner Module Drive", Pages P78 And P79
11.	GD5212	1	Coupler, 1 3/4", 16 Row 30" Only
12.	GD10100	1	Hex Shaft, 7/8" x 31 3/8", 16 Row 30" Only
13.	G11100	1	Hex Socket Button Head Cap Screw, 1/4"-20 x 1/2", Grade 8
	G10227	1	Lock Washer, 1/4"
	G10209	1	Washer, 1/4" USS
14.	G10131	4	Square Head Set Screw, 5/16"-18 x 3/4" P76

SEED RATE TRANSMISSION AND ROW UNIT DRILL SHAFTS

ITEM	PART NO.	QTY. (Per Side)	DESCRIPTION
15.	G10462	-	Cotter Pin, 3/16" x 2"
16.	GD7127	1	Shear Coupler
17.	GA7336	1	Idler W/Bolt-On Sprockets
	GD7426	-	Sprocket, 12 Tooth
	GD1026	-	Sleeve, 1 3/16" Long
	G10210	-	Washer, 3/8" USS
	G10229	-	Lock Washer, 3/8"
	G10047	-	Hex Head Cap Screw, 3/8"-16 x 1 3/4"
18.	GD7612	1	Shaft, 7/8" x 13 1/2"
19.	G3310-80	1	Chain, No. 40, 80 Pitch Including Connector Link
	GR0912	-	Connector Link, No. 40
20.	G10303	-	Carriage Bolt, 5/16"-18 x 1"
	G10232	-	Lock Washer, 5/16"
	G10106	-	Hex Nut, 5/16"-18
21.	GA5548	1	Special Bearing
22.	G3400-01	-	Flangette
23.	G2100-03	-	Bearing, 7/8" Hex Bore, Spherical
24.	G10688	-	Square Head Set Screw, 3/8"-16 x 5/8"
25.	GD11045	-	Lock Clamp
26.	GD0914-106.5	2	Hex Shaft, 7/8" x 106 1/2" (No Holes), Wing, 12 Row 30"
	GD0914-166.75	-	Hex Shaft, 7/8" x 166 3/4" (No Holes), Wing, 16 Row 30"
27.	GA2180	-	Hanger Bearing, 7/8" Hex Bore
28.	G10130	-	Square Head Machine Bolt, 5/16"-18 x 1 3/4"
	G10923	-	Flange Nut, 5/16"-18, No Serration
29.	G10233	-	Machine Bushing, 1", 10 Gauge
30.	GA7052	-	U-Joint W/Grease Fitting, Female, 10 1/4" Long
	GR1557	-	Grease Fitting, 45°, Metric
	GR1297	-	Inboard Yoke And Outer Profile
	GR1294	-	Cross And Bearing Kit
	GR1293	-	Yoke, 7/8" Hex
31.	GA7051	-	U-Joint W/Grease Fitting, Male, 12 1/4" Long
	GR1557	-	Grease Fitting, 45°, Metric
	GR1296	-	Inner Profile
	GR1295	-	Inboard Yoke
	GR1301	-	Spring Pin, 8 mm x 50 mm
	GR1294	-	Cross And Bearing Kit
	GR1293	-	Yoke, 7/8" Hex
32.	GD0914-45	1	Hex Shaft, 7/8" x 45", R.H. Main Frame (No Holes)
	GD0914-35	-	Hex Shaft, 7/8" x 35", L.H. Main Frame (No Holes)
33.	G10004	2	Hex Head Cap Screw, 3/8"-16 x 1 1/4"
	G10229	2	Lock Washer, 3/8"
	G10101	-	Hex Nut, 3/8"-16
34.	GB0287	2	Coupler
35.	G10496	2	External Inverted Snap Ring, 1 1/2"
36.	G11075	2	External Inverted Snap Ring, 7/8"
37.	GD14426	1	Tightener Shaft, 3 3/8"
38.	GD14431	1	Handle
39.	G11078	1	Vinyl Cap
40.	GD14414	1	Torsion Spring, R.H. (Shown)(Used In L.H. Wrap Spring Wrench)
	GD14413	-	Torsion Spring, L.H. (Used In R.H. Wrap Spring Wrench)
41.	GD14432	1	Sleeve, 1 1/4"
42.	GD14429	-	Release Collar, Silver, L.H. (Shown)
	GD14430	1	Release Collar, Gold, R.H.
43	GA7313	1	Sprocket Storage Rod
A.	G1K269	-	Lock Clamp Kit (Items 25 And 28)
B.	G1K381	-	Wrap Spring Wrench Replacement Kit, Silver Collar, L.H. (Items 9, 13 And 35-42) (Shown)
	G1K380	-	Wrap Spring Wrench Replacement Kit, Gold Collar, R.H. (Items 9, 13 And 35-42)

INNER MODULE DRIVE

PTD058/PFA046/PTD077(TWL16d)

12 Row 30" Shown
(Located In Inside Module On 16 Row 30")

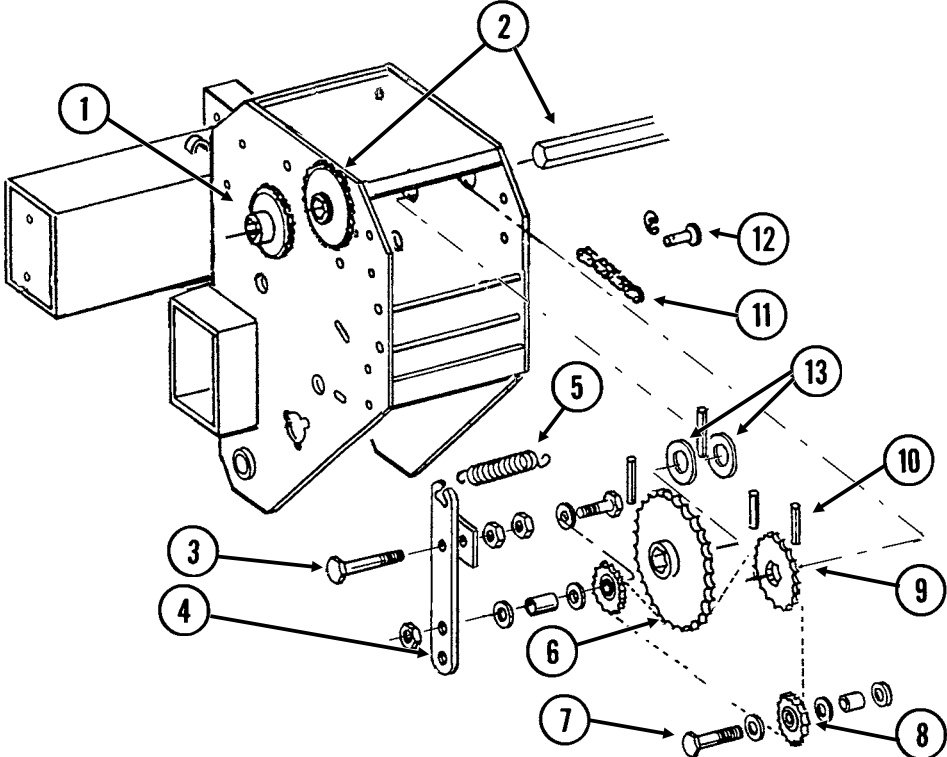

INNER MODULE DRIVE

ITEM	PART NO.	QTY.	DESCRIPTION
		(Per Module)	
1.		-	See "Seed Rate Transmission And Row Unit Drill Shafts", Pages P76 And P77
2.		-	See "Contact Drive Wheel And Drive Shaft(s)", Pages P72-P74
3.	G10743	1	Hex Head Cap Screw, 5/8"-11 x 3 3/4"
	G10503	1	Hex Jam Nut, 5/8"-11, Grade 2
	G10107	1	Lock Nut, 5/8"-11
4.	GA9557	1	Idler W/Sprocket And Hardware, L.H.
	GA9558	-	Idler W/Sprocket And Hardware, R.H. (Shown)
	GA7154	-	Sprocket W/Bearing, 18 Tooth
	G10038	-	Hex Head Cap Screw, 1/2"-13 x 3"
	GD10007	-	Spacer, 1 1/8"
	G10206	-	Washer, 1/2" SAE
	G10111	-	Lock Nut, 1/2"-13
5.	GD5857	1	Spring
6.	GA5194	1	Sprocket, 50 Tooth
7.	G10053	1	Hex Head Cap Screw, 1/2"-13 x 2 1/2"
	GD7889	1	Bushing, 1" O.D. x 9/16" I.D. x 7/16" Long
	G10168	2	Machine Bushing, 1/2", 7 Gauge
	G10111	1	Lock Nut, 1/2"-13
8.	GA7154	1	Sprocket W/Bearing, 18 Tooth
9.	GA5113	1	Sprocket, 28 Tooth
10.	G10602	-	Spring Pin, 1/4" x 1 1/2"
11.	G3310-100	1	Chain, No. 40, 100 Pitch Including Connector Link
	GR0912	-	Connector Link, No. 40
12.	G10870	1	Clevis Pin, 3/8" x 1"
	G10860	1	Retaining Ring, 3/8"
13.	G10345	2	Machine Bushing, 1", 14 Gauge

POINT ROW CLUTCH

PRC019(TWL70d/TWL71d/TWL71/TWL18/A10054)

**L.H. Point Row Clutch Shown
(Used On L.H. Side Of Planter)**

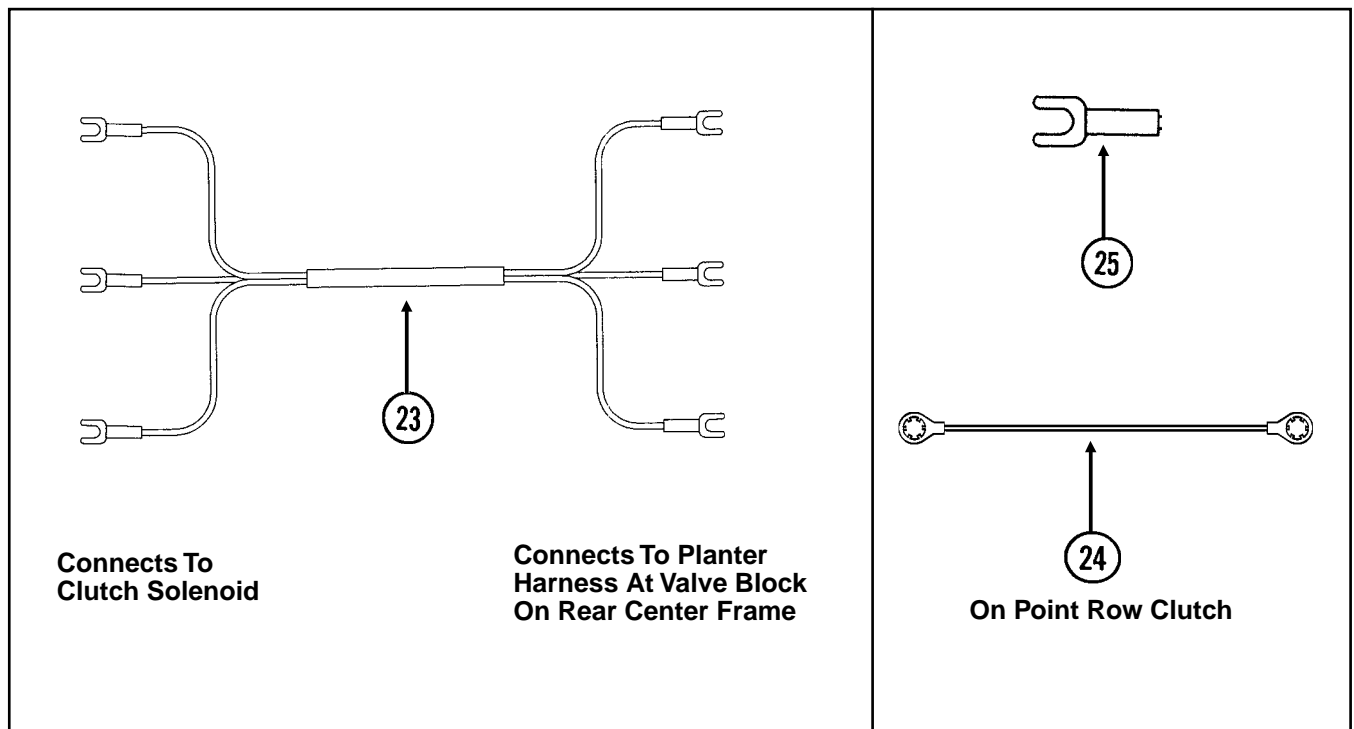
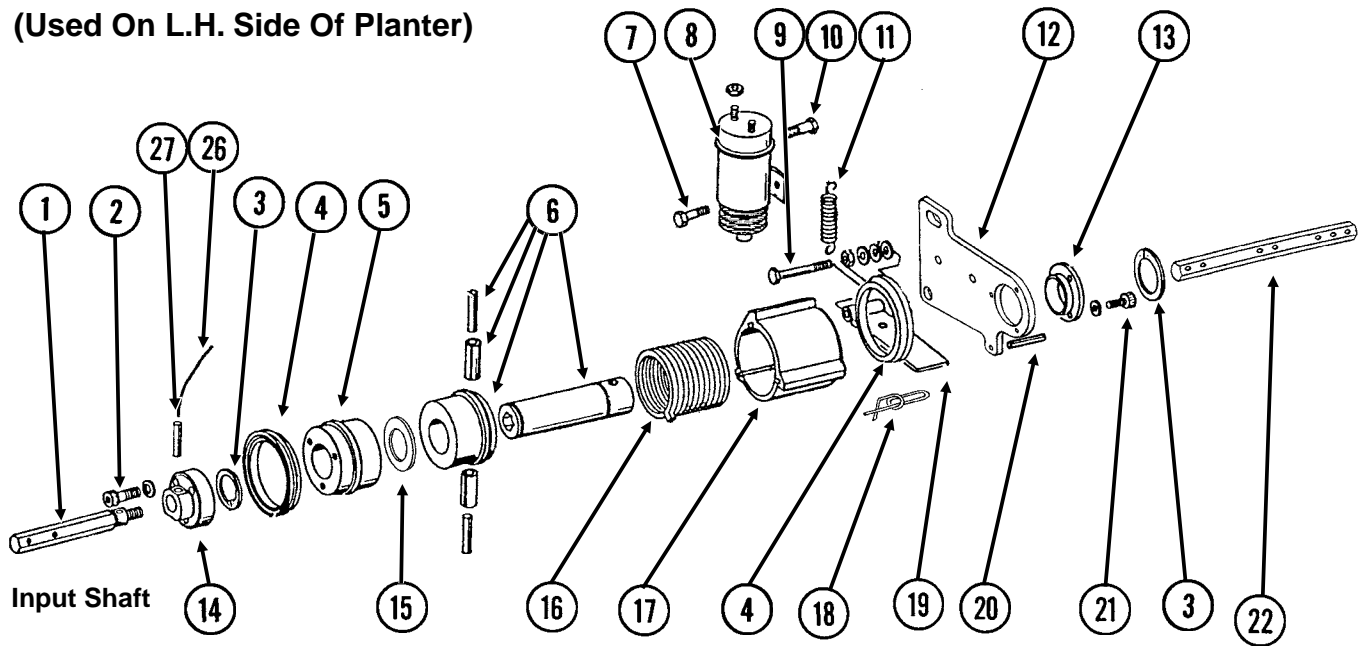

POINT ROW CLUTCH

ITEM	PART NO.	QTY. (Per Assy.)	DESCRIPTION
1.	GD10068	1	Input Shaft, R.H. Threads (Shown)
	GD10069	1	Input Shaft, L.H. Threads
2.	G10374	3	Hex Socket Head Screw, 1/4"-20 x 1"
	G10227	3	Lock Washer, 1/4"
3.	G10496	2	External Inverted Snap Ring, 1 1/2"
4.	GD14512	2	V-Ring Seal
5.	GD10104	1	Input Hub
6.	GA7137	1	Hub/Sleeve Assembly W/Spring Pins
	G10765	-	Spring Pin, 1/4" x 1"
	G10804	-	Spring Pin, 5/32" x 7/8"
7.	G10023	1	Hex Head Cap Screw, 1/4"-20 x 3/4"
	G10227	1	Lock Washer, 1/4"
	G10103	1	Hex Nut, 1/4"-20
8.	GA8393	1	Solenoid Complete
	GR1306	1	Snap Ring
	GR1303	1	Spring
	GR1304	1	Boot
	GR1305	1	Plunger
9.	G10049	1	Hex Head Cap Screw, 3/8"-16 x 2 1/2"
	G10101	1	Hex Nut, 3/8"-16
	G10203	1	Washer, 3/8" SAE
	G10229	2	Lock Washer, 3/8"
	G10497	1	Hex Jam Nut, 3/8"-16, Grade 2
10.	G10900	1	Hex Socket Head Cap Screw, 1/4"-20 x 1 3/4", Grade 8
	G10227	1	Lock Washer, 1/4"
	G10103	2	Hex Nut, 1/4"-20
11.	GD10123	1	Spring
12.	GD10103	1	Mounting Plate
13.	GD9667	1	Bushing
14.	GD10070	1	Coupler W/R.H. Threads (Shown)
	GD10071	1	Coupler W/L.H. Threads
15.	GD14513	1	Felt Washer
16.	GD9671	-	Spring, L.H. (Shown)
	GD9672	-	Spring, R.H.
17.	GD10102	1	Stop Collar
18.	GD11120	1	Rue Ring Cotter, 5/16"
19.	GD10510	1	Actuator Arm
20.	G10859	1	Spring Pin, 3/16" x 2 1/4"
21.	G10253	3	Hex Socket Head Screw, No. 10-32 x 1/2"
	G10257	3	Lock Washer, No. 10
22.	GD10543	-	Hex Shaft, 7/8" x 13"
23.	GA9479	1	Wiring Harness, 228", R.H. Side, 12 Row 30"
	GA9480	-	Wiring Harness, 264", L.H. Side, 12 Row 30"
	GA9483	-	Wiring Harness, 252", R.H. Side, 16 Row 30"
	GA9482	-	Wiring Harness, 300", L.H. Side, 16 Row 30"
24.	GA10054	-	Ground Cable, Green
25.	G10996	-	Fork Terminal
26.	GD13524-01	1	Lock Wire, 10", Stainless Steel
27.	G10546	1	Spring Pin, 3/16" x 1 1/4"
A.	GA7110	-	Point Row Clutch Assembly, R.H. (R.H. Side Of Machine) (Items 1-21, 24, 26 And 27)
	GA7111	-	Point Row Clutch Assembly, L.H. (L.H. Side Of Machine) (Items 1-21, 24, 26 And 27)

TWO-SPEED POINT ROW CLUTCH

PRC023(FF47c/A7274/TWL71/TWL18/A10054)

**L.H. Two-Speed Point Row Clutch Shown
(Used On L.H. Side Of Planter)**

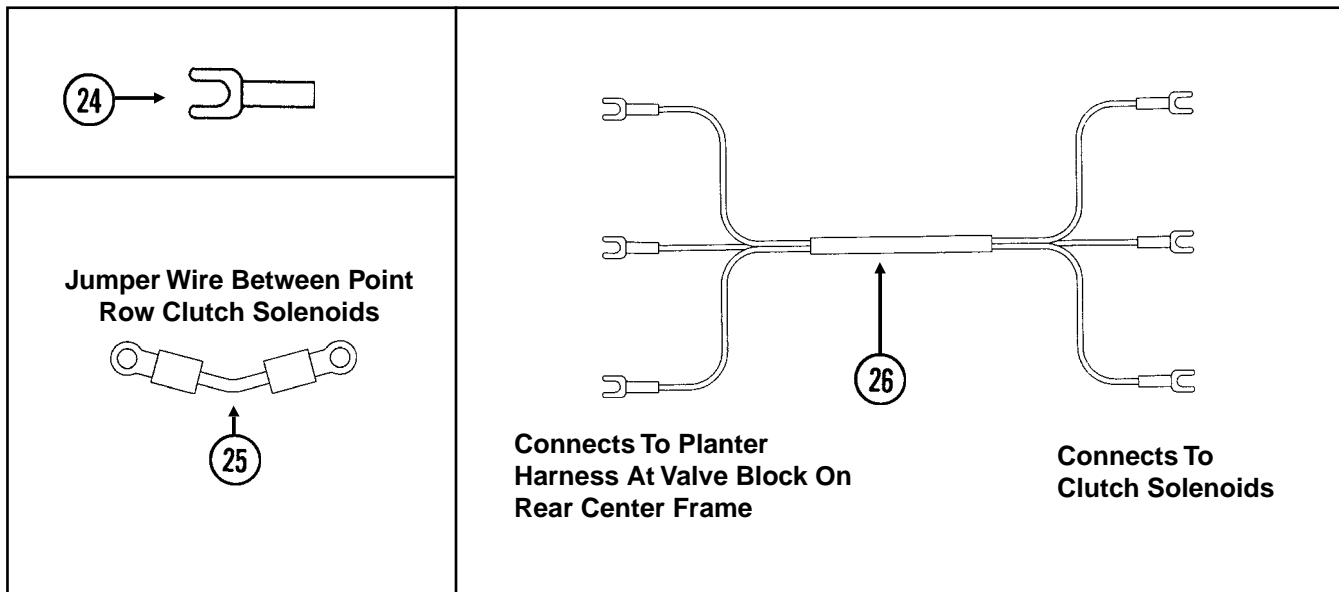
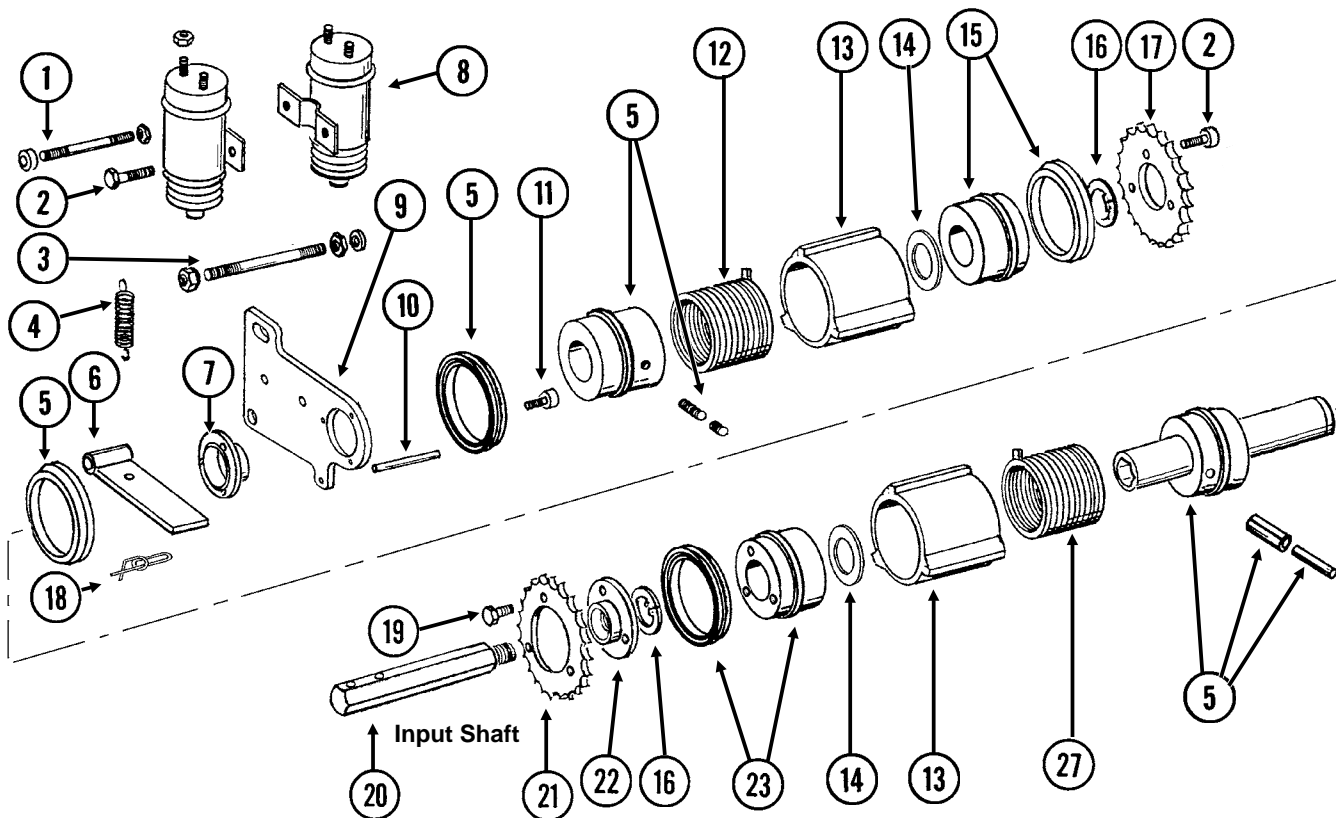

TWO-SPEED POINT ROW CLUTCH

ITEM	PART NO.	QTY. (Per Assy.)	DESCRIPTION
1.	GD10635	1	Threaded Rod, 1/4"-20 x 3 1/2"
	G10103	2	Hex Nut, 1/4"-20
	G10227	2	Lock Washer, 1/4"
2.	GD10282	2	Allen Nut, 1/4"-20
	G10023	4	Hex Head Cap Screw, 1/4"-20 x 3/4"
	G10227	4	Lock Washer, 1/4"
	G10103	1	Hex Nut, 1/4"-20
3.	GD10636	1	Threaded Rod, 3/8"-16 x 4 1/4"
	G10108	2	Lock Nut, 3/8"-16
	G10229	2	Lock Washer, 3/8"
	G10101	2	Hex Nut, 3/8"-16
4.	GD10123	2	Spring
5.	GA7463	1	Hub/Sleeve Assembly W/Seals, Sleeve, Pins And Screws
	GD10120	-	Seal
	GD10584	-	Sleeve
	G10873	-	Hex Socket Set Screw, 5/16"-18 x 3/4"
	G10872	-	Hex Socket Set Screw, 5/16"-18 x 1/4"
	G10804	-	Spring Pin, 5/32" x 7/8"
	G10765	-	Spring Pin, 1/4" x 1"
	GD10510	2	Actuator Arm
	GD10586	1	Bushing
8.	GA8393	2	Solenoid Complete
	GR1306	-	Snap Ring
	GR1303	-	Spring
	GR1304	-	Boot
	GR1305	-	Plunger
	GD10103	1	Mounting Plate
10.	G10859	1	Spring Pin, 3/16" x 2 1/4"
11.	G10876	3	Hex Socket Head Screw, No. 10-32 x 1/4"
12.	GD9671	2	Spring, L.H. (Shown)
13.	GD10585	2	Stop Collar
14.	GD14513	2	Felt Washer
15.	GA9572	1	Hub W/Seal
	GD10120	-	Seal
16.	G10496	2	External Inverted Snap Ring, 1 1/2"
17.	GD10579	1	Output Sprocket, 28 Tooth
18.	GD11120	2	Rue Ring Cotter, 5/16"
19.	G10374	3	Hex Socket Head Screw, 1/4"-20 x 1"
	GD10588	3	Key
	GD10068	1	Input Shaft, R.H. Threads (Shown)
20.	GD10069	-	Input Shaft, L.H. Threads
	GD10578	1	Input Sprocket, 28 Tooth
21.	GD10638	1	Coupler W/R.H. Threads (Shown)
	GD10587	-	Coupler W/L.H. Threads
23.	GA9571	1	Hub W/Seal
	GD10120	-	Seal
24.	G10996	-	Fork Terminal
25.	GA7274	1	Jumper Wire W/Ring Terminals, 2 3/16" (Between Solenoids)
26.	GA9479	1	Wiring Harness, 228", R.H. Side, 12 Row 30"
	GA9480	-	Wiring Harness, 264", L.H. Side, 12 Row 30"
	GA9483	-	Wiring Harness, 252", R.H. Side, 16 Row 30"
	GA9482	-	Wiring Harness, 300", L.H. Side, 16 Row 30"
	GD9672	-	Spring, R.H.

TWO-SPEED POINT ROW CLUTCH WHEEL MODULE EXTENSION

PRC022/PRC019/PTD078/PTD079(TWL77e/TWL84b/TWL79a/TWL80b)

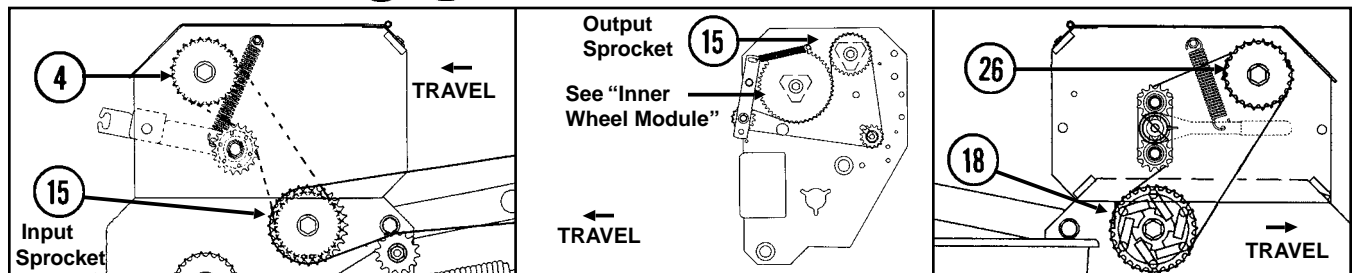
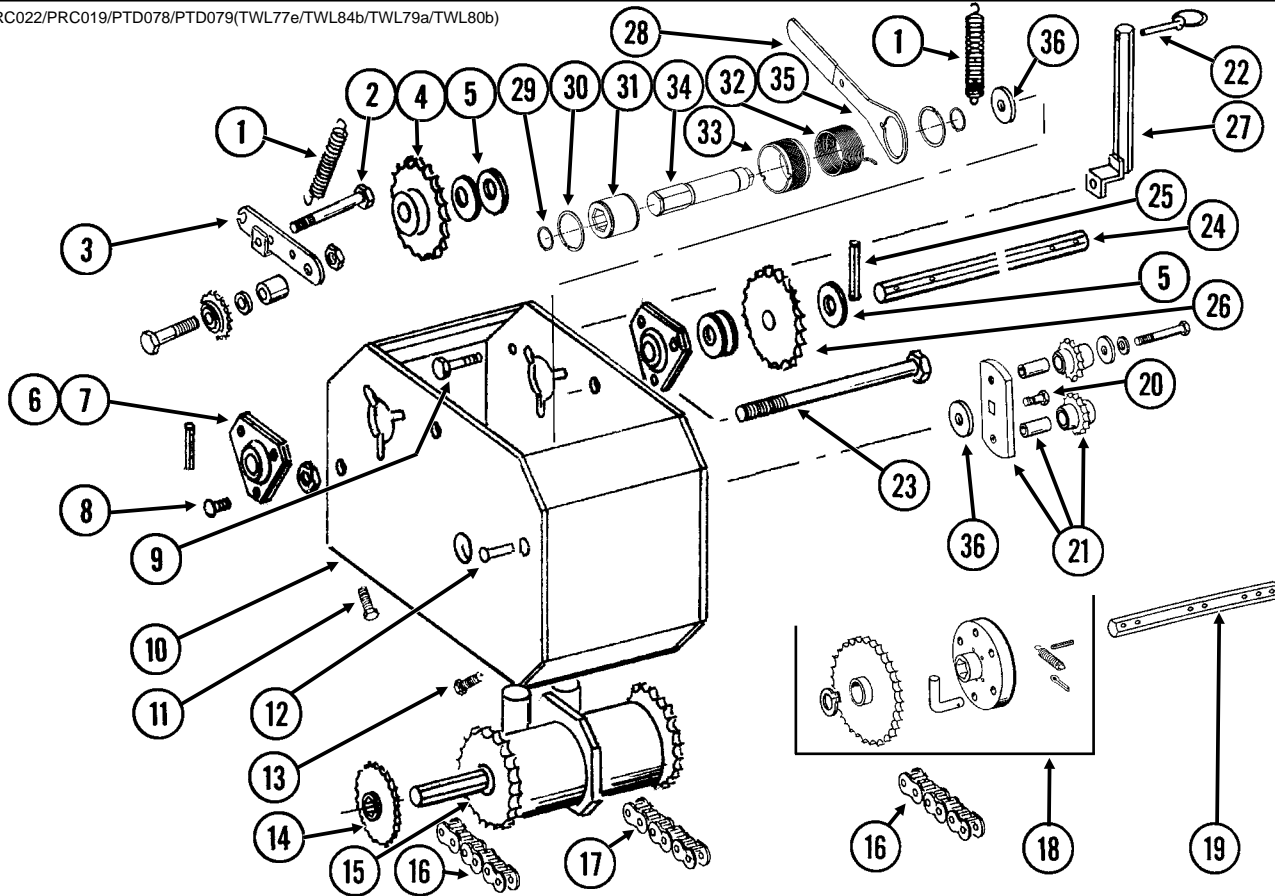

ITEM	PART NO.	QTY.	DESCRIPTION
		(Per Assy.)	
1.	GD5857	2	Spring
2.	G10036	1	Hex Head Cap Screw, 5/8"-11 x 4"
	G10107	1	Lock Nut, 5/8"-11
	G10104	1	Hex Nut, 5/8"-11
3.	GA9918	1	Idler W/Sprocket And Hardware
	GD10356	-	Bushing, 3/4" Long
	G10128	-	Machine Bushing, 1/2", 14 Gauge
	G10501	-	Hex Jam Nut, 1/2"-13, Grade 2
	G10053	-	Hex Head Cap Screw, 1/2"-13 x 2 1/2"
	GA7154	-	Sprocket W/Bearing, 18 Tooth
4.	GA5113	1	Sprocket, 28 Tooth
5.	G10233	-	Machine Bushing, 1", 10 Gauge
6.	G3400-01	-	Flangette
7.	G2100-03	-	Bearing, 7/8" Hex Bore, Spherical
8.	G10312	6	Carriage Bolt, 5/16"-18 x 3/4"
	G10232	6	Lock Washer, 5/16"
	G10106	6	Hex Nut, 5/16"-18
9.	G10037	1	Hex Head Cap Screw, 1/2"-13 x 1 1/4"
	G10216	1	Washer, 1/2" USS
	G10228	1	Lock Washer, 1/2"
	G10102	1	Hex Nut, 1/2"-13

TWO-SPEED POINT ROW CLUTCH WHEEL MODULE EXTENSION

ITEM	PART NO.	QTY. (Per Assy.)	DESCRIPTION
10.	GA7306	1	Extension Bracket
11.	G10857	2	Hex Head Cap Screw, 1/4"-20 x 1 1/4"
	G10209	2	Washer, 1/4" USS
	G10227	2	Lock Washer, 1/4"
	G10103	2	Hex Nut, 1/4"-20
12.	G10408	1	Clevis Pin, 5/16" x 3/4"
	G10409	1	Retaining Ring, 5/16"
13.	G10064	2	Hex Head Cap Screw, 1/4"-20 x 1"
	G10209	2	Washer, 1/4" USS
	G10227	2	Lock Washer, 1/4"
	G10103	2	Hex Nut, 1/4"-20
14.		-	See "Contact Drive Wheel And Drive Shaft(s)", Pages P72-P74
15.		-	See "Two-Speed Point Row Clutch", Pages P82 And P83
16.	G3310-74	2	Chain, No. 40, 74 Pitch Including Connector Link
	GR0912	-	Connector Link, No. 40
17.	G3310-100	1	Chain, No. 40, 100 Pitch Including Connector Link
	GR0912	-	Connector Link, No. 40
18.	GA7320	1	Overrunning Sprocket Assembly, R.H.
	GA7321	-	Overrunning Sprocket Assembly, L.H.
	G10430	1	External Retaining Ring, 1 1/4"
	GD1255	6	L-Pin
	G10546	6	Spring Pin, 3/16" x 1 1/4"
	G10470	6	Cotter Pin, 5/32" x 1"
	GD10366	6	Spring
	GA7317	1	Block
	GA7319	1	Sprocket W/Bushing, 30 Tooth
19.	GD10543	1	Hex Shaft, 7/8" x 13"
20.	G11100	1	Hex Socket Button Head Cap Screw, 1/4"-20 x 1/2", Grade 8
	G10227	1	Lock Washer, 1/4"
	G10209	1	Washer, 1/4" USS
21.	GA7336	1	Idler W/Bolt-On Sprockets
	GD7426	-	Sprocket, 12 Tooth
	GD1026	-	Sleeve, 1 3/16" Long
	G10210	-	Washer, 3/8" USS
	G10229	-	Lock Washer, 3/8"
	G10047	-	Hex Head Cap Screw, 3/8"-16 x 1 3/4"
22.	GD2558	2	Lynch Pin, 1/4"
23.	G10595	1	Hex Head Cap Screw, 3/8"-16 x 10"
	G10108	1	Lock Nut, 3/8"-16
24.	GD10355	1	Shaft, 7/8" x 13 3/4"
25.	G10602	3	Spring Pin, 1/4" x 1 1/2"
26.	GA5109	1	Sprocket, 24 Tooth
	GA5105	1	Sprocket, 15 Tooth
	GA5106	1	Sprocket, 17 Tooth
	GA5112	1	Sprocket, 27 Tooth
	GA5108	-	Sprocket, 23 Tooth (From Transmission)
	GA5110	-	Sprocket, 25 Tooth (From Transmission)
	GA5111	-	Sprocket, 26 Tooth (From Transmission)
27.	GA7313	1	Sprocket Storage Rod
28.	G11078	1	Vinyl Cap
29.	G10496	2	External Inverted Snap Ring, 1 1/2"
30.	G11075	2	External Inverted Snap Ring, 7/8"
31.	GD14432	1	Sleeve, 1 1/4"
32.	GD14414	1	Torsion Spring, R.H. (Shown)(Used In L.H. Wrap Spring Wrench)
	GD14413	-	Torsion Spring, L.H. (Used In R.H. Wrap Spring Wrench)
33.	GD14429	-	Release Collar, Silver, L.H. (Shown)
	GD14430	1	Release Collar, Gold, R.H.
34.	GD14426	1	Tightener Shaft, 3 3/8"
35.	GD14431	1	Handle
36.	G10235	2	Machine Bushing, 7/8", 14 Gauge
A.	G1K381	-	Wrap Spring Wrench Replacement Kit, Silver Collar, L.H. (Items 20 And 28-36) (Shown)
	G1K380	1	Wrap Spring Wrench Replacement Kit, Gold Collar, R.H. (Items 20 And 28-36)

ROW MARKER ASSEMBLY

12 ROW 30"

MKR019/MKR027(MKR31)

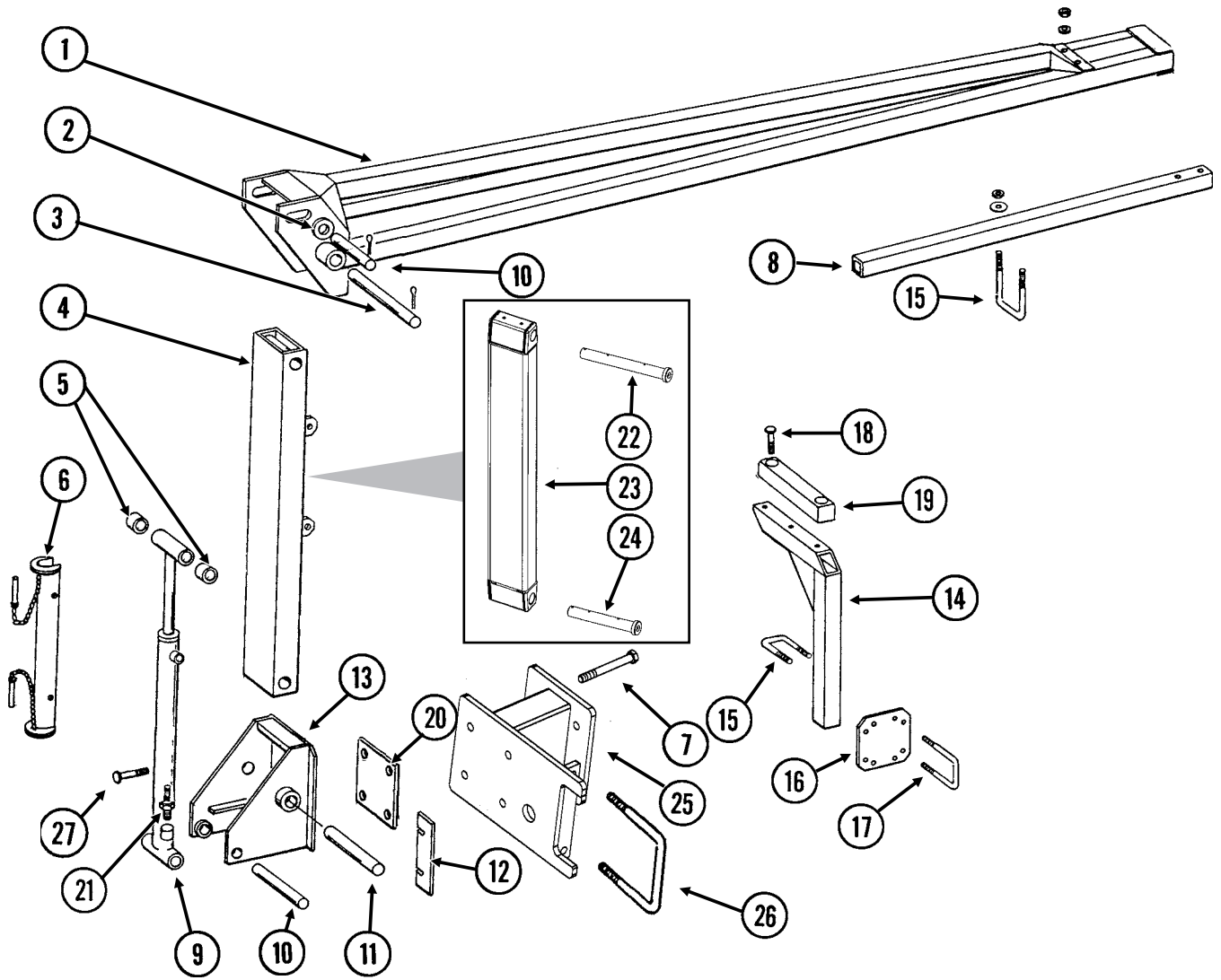

ROW MARKER ASSEMBLY

12 ROW 30"

ITEM	PART NO.	QTY. (Per Assy.)	DESCRIPTION
1.	GA4353	1	Arm W/Grease Fittings, Second Stage, 110"
	G10641	-	Grease Fitting, 1/8" NPT
2.	G10226	-	Washer, 1 1/4" SAE
3.	GD3214	1	Pin, 1 1/4" x 12 1/4"
	G10460	2	Cotter Pin, 1/4" x 2"
4.	GA4611	1	Arm W/Grease Fittings, First Stage
	G10641	-	Grease Fitting, 1/8" NPT
5.	GD0752-41	4	Sleeve, 1"
6.	GA8170	1	Safety Lockup W/Detent Pins, 19 3/8"
	G10536	-	Detent Pin, 1/2" x 2 1/2" Grip
7.	G10011	4	Hex Head Cap Screw, 5/8"-11 x 5 1/2"
	GD7805	8	Special Washer, 5/8", Hardened
	G10230	4	Lock Washer, 5/8"
	G10104	4	Hex Nut, 5/8"-11
8.	GD0453-05	1	Extension Tube, 55"
9.		-	See "Row Marker (Cushion) Cylinder", Page P100
10.	GD2161	2	Pin, 1 1/4" x 8 1/4"
	G10460	4	Cotter Pin, 1/4" x 2"
11.	GD0652	1	Pin, 1 1/4" x 9 1/2"
	G10460	2	Cotter Pin, 1/4" x 2"
12.	GD10792	-	Shim, 2 1/2" x 7 1/4", 16 Gauge (As Required)
13.	GA5130	1	Mount
14.	GA7042	1	Stand, 20" (12 Row 30" Only)
15.	GD2721	3	U-Bolt, 2" x 2" x 1/2"-13
	G10228	6	Lock Washer, 1/2"
	G10102	6	Hex Nut, 1/2"-13
16.	GD9981	1	Bar
17.	GD1138	2	U-Bolt, 2 1/2" x 2 1/2" x 1/2"-13
	G10216	4	Washer, 1/2" USS
	G10228	4	Lock Washer, 1/2"
	G10102	4	Hex Nut, 1/2"-13
18.	G10017	2	Hex Head Cap Screw, 1/2"-13 x 1 1/2"
	G10206	2	Washer, 1/2" SAE
	G10111	2	Lock Nut, 1/2"-13
19.	GA9088	-	Molded Stop, 12 1/4" Long
20.	GD13360	2	Plate, 6" x 6"
21.		-	See "Hydraulic Hoses And Fittings On Planter Frame", Pages P114-P117
22.	GA11766	-	Pin W/Grease Fitting, 1 1/4" x 11 13/16"
	G10640	-	Grease Fitting, 1/4"-28
23.	GA11590	-	Arm, First Stage
24.	GA11767	-	Pin W/Grease Fitting, 1 1/4" x 9 1/2"
	G10640	-	Grease Fitting, 1/4"-28
25.	GA10828	1	Spacer (L.H. Marker Only)
26.	GD1113	1	U-Bolt, 5" x 7" x 5/8"-11
	G10230	2	Lock Washer 5/8"
	G10104	2	Hex Nut, 5/8"-11
27.	G10009	-	Hex Head Cap Screw, 5/8"-11 x 2 1/2"
	GD7805	-	Special Washer, 5/8", Hardened
	G10230	-	Lock Washer, 5/8"
	G10104	-	Hex Nut, 5/8"-11

ROW MARKER ASSEMBLY

16 ROW 30"

MKR019/MKR023MKR027(MKR32)

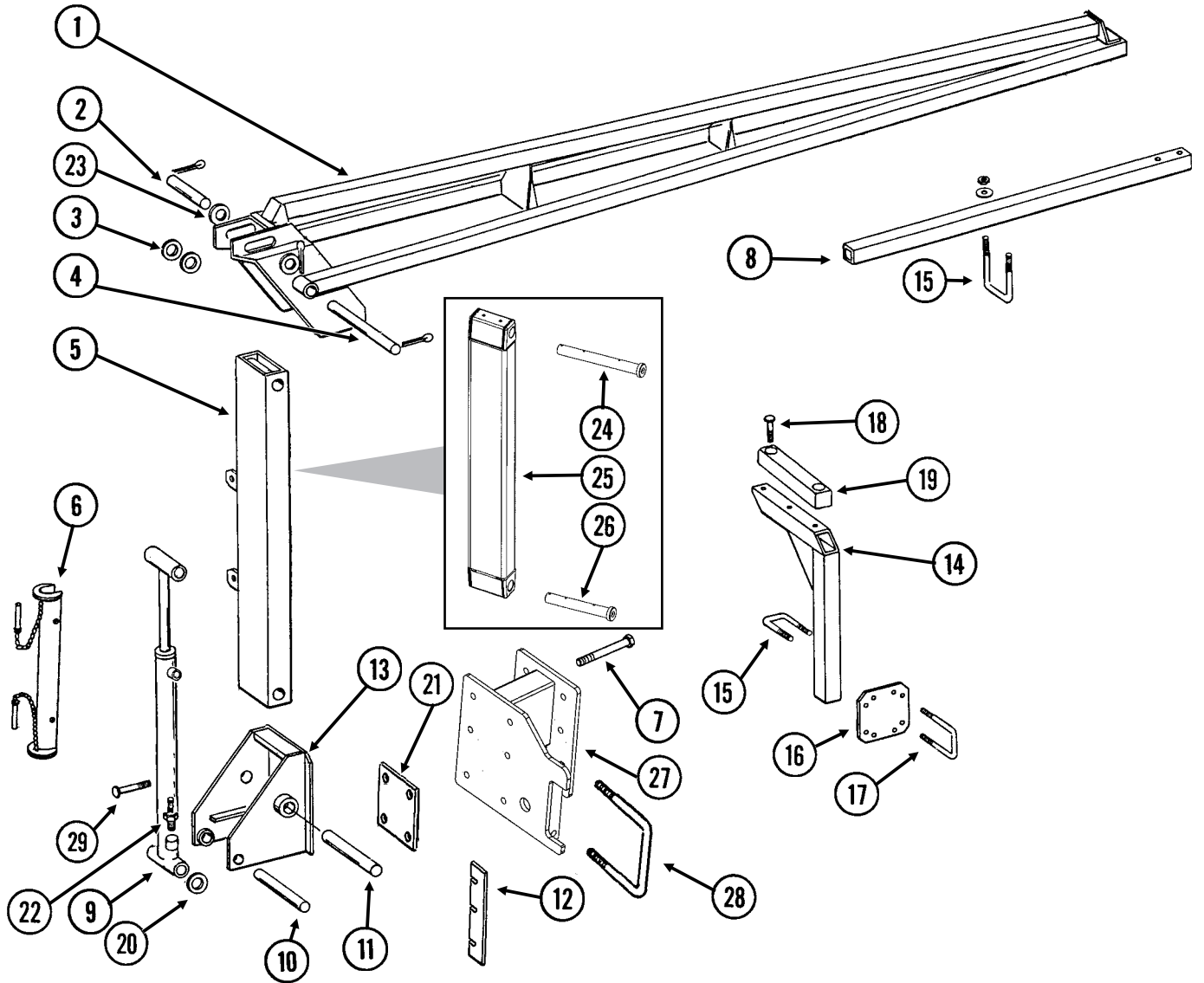

ROW MARKER ASSEMBLY

16 ROW 30"

ITEM	PART NO.	QTY.	DESCRIPTION
		(Per Assy.)	
1.	GA7118	-	Arm, Second Stage, 172 ¼"
2.	GD1701	1	Pin, 1 ¼" x 6 ½"
	G10460	2	Cotter Pin, ¼" x 2"
3.	G10322	-	Machine Bushing, 1 ¼", 18 Gauge
4.	GD0737	1	Pin, 1 ¼" x 13 ¼"
	G10460	2	Cotter Pin, ¼" x 2"
5.	GA4878	1	Arm W/Grease Fittings, First Stage, R.H.
	GA4983	-	Arm W/Grease Fittings, First Stage, L.H.
	G10641	-	Grease Fitting, ⅛" NPT
6.	GA8170	1	Safety Lockup W/Detent Pins, 19 ⅜"
	G10536	-	Detent Pin, ½" x 2 ½" Grip
7.	G10011	6	Hex Head Cap Screw, ⅝"-11 x 5 ½" (If Applicable)
	GD7805	8	Special Washer, ⅝", Hardened
	G10230	6	Lock Washer, ⅝"
	G10104	6	Hex Nut, ⅝"-11
8.	GD0453-05	-	Extension Tube, 55"
9.		-	See "Row Marker (Cushion) Cylinder", Page P100
10.	GD0652	1	Pin, 1 ¼" x 9 ½"
	G10460	2	Cotter Pin, ¼" x 2"
11.	GD7209	1	Pin, 1 ¼" x 11 ½"
	G10049	1	Hex Head Cap Screw, ⅜"-16 x 2 ½"
	G10108	1	Lock Nut, ⅜"-16
12.	GD10793	-	Shim, 2 ½" x 12 ½", 16 Gauge (As Required) (Shown)
	GD11791	-	Shim, 2 ½" x 8 ¼", 16 Gauge (As Required)
13.	GA4877	1	Mount
14.	GA7043	1	Stand, 30"
15.	GD2721	3	U-Bolt, 2" x 2" x ½"-13
	G10228	6	Lock Washer, ½"
	G10102	6	Hex Nut, ½"-13
16.	GD9981	1	Bar
17.	GD1138	2	U-Bolt, 2 ½" x 2 ½" x ½"-13
	G10216	4	Washer, ½" USS
	G10228	4	Lock Washer, ½"
	G10102	4	Hex Nut, ½"-13
18.	G10017	2	Hex Head Cap Screw, ½"-13 x 1 ½"
	G10206	2	Washer, ½" SAE
	G10111	2	Lock Nut, ½"-13
19.	GA9088	-	Molded Stop, 12 ¼" Long
20.	G10979	4	Special Washer, 1 ¼" (As Required)
21.	GD13359	2	Plate, 7" x 7"
22.		-	See "Hydraulic Hoses And Fittings On Planter Frame", Pages P114-P117
23.	G10226	2	Washer, 1 ¼" SAE
	G10322	2	Machine Bushing, 1 ¼", 18 Gauge
24.	GA11768	-	Pin W/Grease Fitting, 1 ¼" x 13"
	G10640	-	Grease Fitting, ¼"-28
25.	GA11569	-	Arm, First Stage, L.H. (Shown)
	GA11568	-	Arm, First Stage, R.H.
26.	GA11769	-	Pin W/Grease Fitting, 1 ¼" x 11 ½"
	G10640	-	Grease Fitting, ¼"-28
27.	GA10829	1	Spacer (L.H. Marker Only)
28.	GD1113	1	U-Bolt, 5" x 7" x ⅝"-11
	G10230	2	Lock Washer, ⅝"
	G10104	2	Hex Nut, ⅝"-11
29.	G10009	-	Hex Head Cap Screw, ⅝"-11 x 2½"
	GD7805	-	Special Washer, ⅝", Hardened
	G10230	-	Lock Washer, ⅝"
	G10104	-	Hex Nut, ⅝"-11

ROW MARKER SPINDLE/HUB/BLADE

MKR020(MKR4)

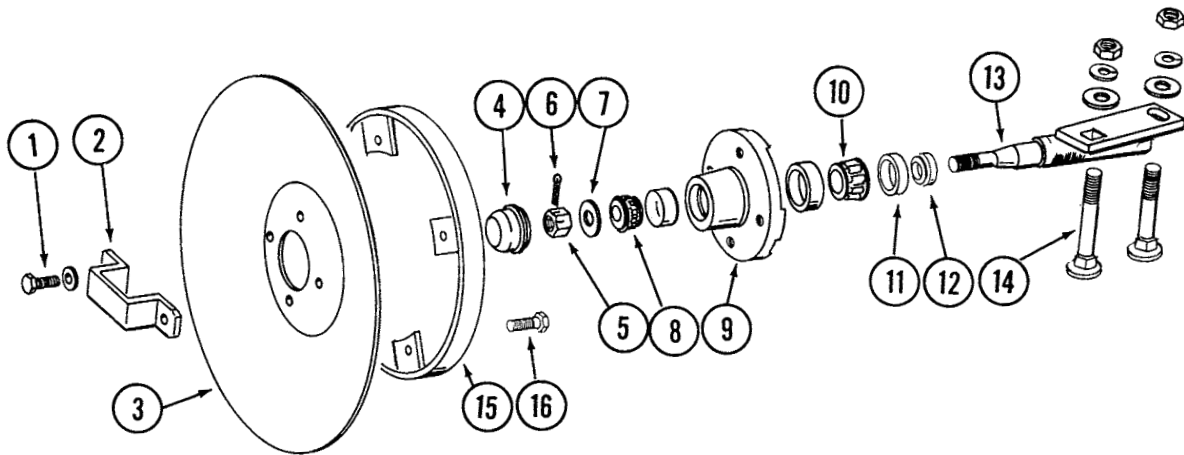

ITEM	PART NO.	QTY.	DESCRIPTION
		(Per Assy.)	
1.	G10722	4	Hex Head Cap Screw, 1/2"-20 x 1"
	G10228	4	Lock Washer, 1/2"
2.	GD2597	1	Retainer
3.	GD0746	1	Disc Blade, Solid, 16" (Shown)
	GD10283	-	Disc Blade, Notched, 16" (Optional)
4.	GD0840	1	Dust Cap
5.	G10725	1	Slotted Hex Nut, 5/8"-18
6.	G10544	1	Cotter Pin, 5/32" x 1"
7.	G10724	1	Washer, 5/8" SAE
8.	GA0257	1	Bearing
9.	GA0167	1	Hub W/Cups, 4 Bolt
	GR0151	-	Outer Cup
	GR0150	-	Inner Cup
10.	GA0245	1	Bearing
11.	GA0243	1	Grease Seal
12.	GA0899	1	Rubber Seal
13.	GA1676	1	Spindle, R.H.
	GA1677	-	Spindle, L.H. (Shown)
14.	G10844	2	Carriage Bolt, 1/2"-13 x 3 1/2"
	G10168	2	Machine Bushing, 1/2", 7 Gauge
	G10228	2	Lock Washer, 1/2"
	G10102	2	Hex Nut, 1/2"-13
15.	GA5853	1	Depth Band
16.	G10019	4	Hex Head Cap Screw, 5/16"-18 x 1"
	G10109	4	Lock Nut, 5/16"-18, Grade 8
A.	GA1679	-	Hub And Spindle Assembly, L.H. (Items 1, 2 And 4-13)
	GA1678	-	Hub And Spindle Assembly, R.H. (Items 1, 2 And 4-13)

ROTATION CYLINDER, ALL SIZES

(CYL11g)

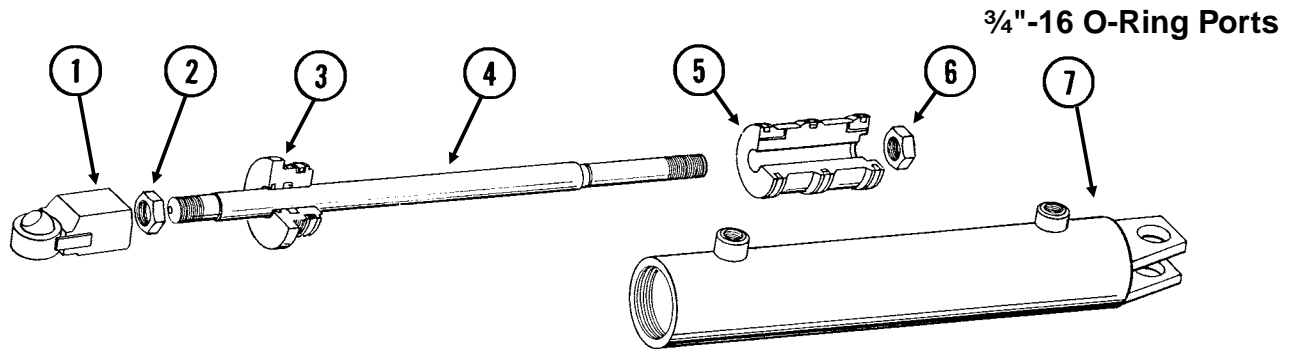

ITEM	PART NO.	QTY.	DESCRIPTION
1.	GA7221	1	Threaded Ball Joint End
2.	G10509	1	Hex Jam Nut, 1 1/4"-12, Grade 2
3.	GD11988	1	Gland
4.	GD14059	1	Rod
5.	GD11992	1	Piston
6.	G10972	1	Lock Nut, 1 1/4"-12
7.	A9018	1	Barrel (Non-Stock Item)
A.	GA9842	-	Cylinder Complete, 4" x 20" <i>(Part Number Stamped On Barrel)</i>
B.	GR1524	-	Seal Kit, Includes: (2) O-Rings, (1) U-Cup, (1) Wiper, (1) Seal, (2) Cast Iron Rings, (1) BU Ring, (1) Expander

STABILIZER CYLINDER, ALL SIZES

(CYL60)

3/4"-16 O-Ring Ports

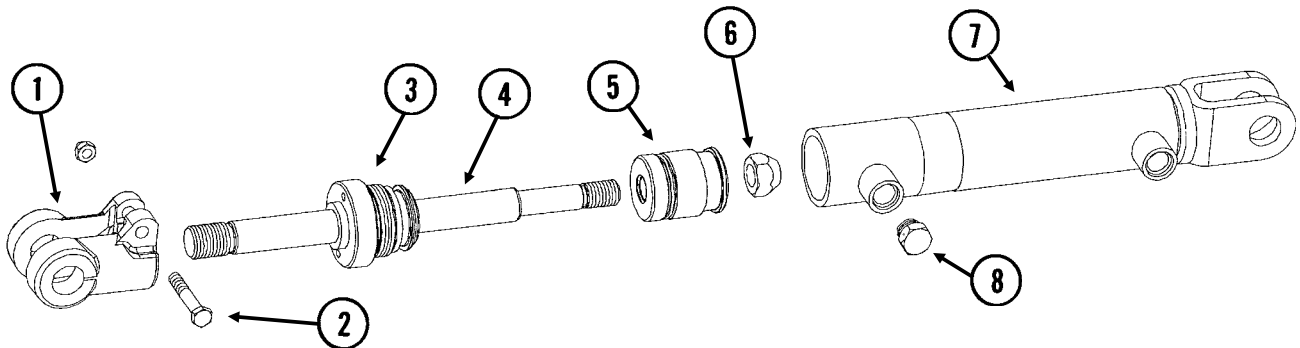

ITEM	PART NO.	QTY.	DESCRIPTION
1.	GD11950	1	Clevis
2.	G10939	1	Hex Head Cap Screw, 3/8"-16 x 2 1/4"
	G10108	1	Lock Nut, 3/8"-16
3.	GD12510	1	Gland
4.	GD16066	1	Rod
5.	GD16065	1	Piston
6.	G10967	1	Lock Nut, 3/4"-16
7.	A8775	1	Barrel (Non-Stock Item)
8.	GA5531	1	Breather Plug W/O-Ring, 3/4"-16 O-Ring
	GR1037	-	O-Ring
A.	GA10947	-	Cylinder Complete, 2" x 6 7/16" (Part Number Stamped On Barrel) (Items 1-7)
B.	GR1738	-	Seal Kit, Includes: (1) T-Seal, (2) O-Rings, (1) BU Ring, (1) U-Cup, (1) Wiper, (1) U-Cup Seal, (1) Wear Ring, (1) IS511 Instruction

STABILIZER CYLINDER, ALL SIZES

(CYL60d)

3/4"-16 O-Ring Ports

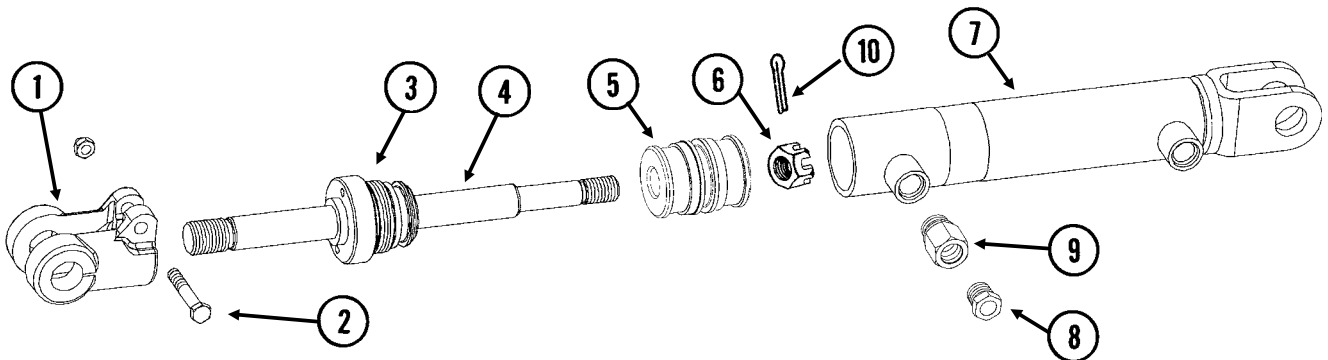

ITEM	PART NO.	QTY.	DESCRIPTION
1.	GD11950	1	Clevis
2.	G10939	1	Hex Head Cap Screw, 3/8"-16 x 2 1/4"
	G10108	1	Lock Nut, 3/8"-16
3.	GD17080	1	Gland
4.	GD17079	1	Rod
5.	GD17078	1	Piston
6.	G10723	1	Slotted Hex Nut, 3/4"-16, Grade 2
7.	A8775	1	Barrel (Non-Stock Item)
8.	GA11980	1	Breather Plug, 3/8" NPT
9.	G6405-08-06	1	Connector W/O-Ring, 3/8" Female NPT To 3/4" Male O-Ring
	GR1037	-	O-Ring
10.	G10827	1	Cotter Pin, 1/8" x 1 3/4"
A.	GA11957	-	Cylinder Complete, 2" x 6 7/16" (Part Number Stamped On Barrel) (Items 1-7)
B.	GR1775	-	Seal Kit, Includes: (1) T-Seal, (2) O-Rings, (1) BU Ring, (1) U-Cup, (1) Wiper, (1) U-Cup Seal, (1) Wear Ring, (1) IS511 Instruction

CENTER LIFT CYLINDER, 12 ROW 30"

(CYL54c/D12239)

Port Type Rephasing

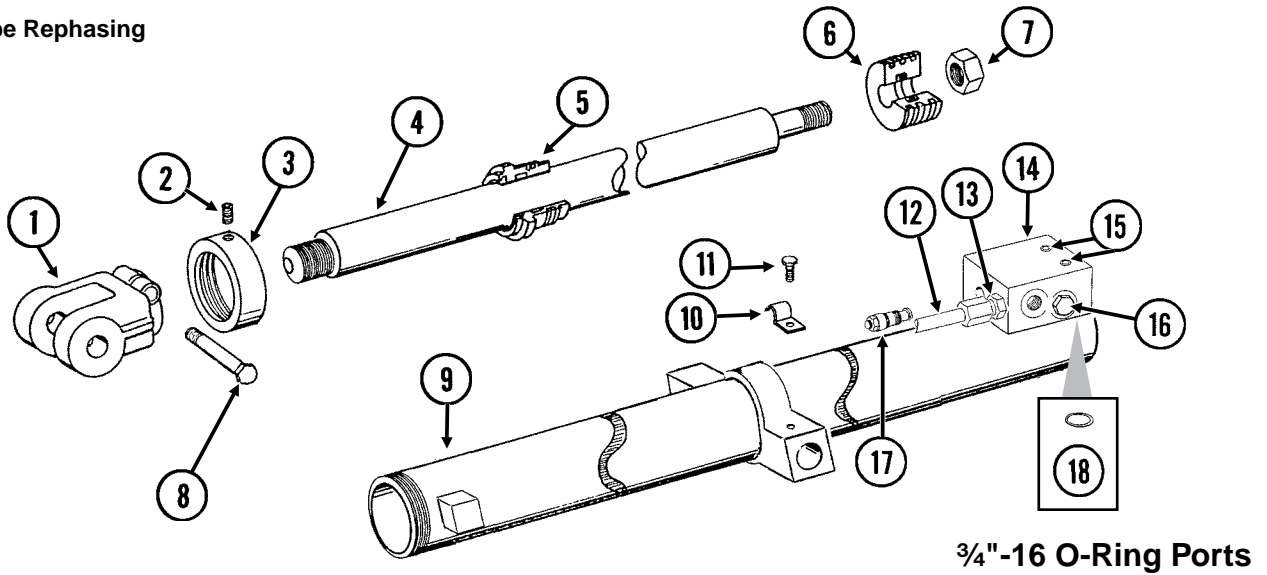

ITEM	PART NO.	QTY.	DESCRIPTION
1.	GD11951	1	Clevis
2.	G10907	1	Set Screw, 1/4"-20 x 1/4"
3.	GD11193	1	Cap
4.	GD14510	1	Rod
5.	GD10211	1	Gland
6.	GD11253	1	Piston
7.	G10958	1	Lock Nut, 1"-14
8.	G10939	1	Hex Head Cap Screw, 3/8"-16 x 2 1/4"
	G10108	1	Lock Nut, 3/8"-16
9.	GA10099	1	Barrel
10.	GD12657	1	Half Clip
11.	G10022	1	Hex Head Cap Screw, 1/4"-20 x 1/2"
	G10227	1	Lock Washer, 1/4"
12.	GA10094	1	Steel Hydraulic Line, 47 5/16"
13.	G6400-08	-	Connector W/O-Ring, 3/4"-16 Male JIC To O-Ring
	GR1037	0	O-Ring
14.	GD11579	1	Block
15.	G10932	2	Hex Socket Head Cap Screw, 5/16"-18 x 2", Grade 8
16.	G6408-08	-	Plug W/O-Ring, 3/4"-16 O-Ring
	GR1037	-	O-Ring
17.	GA8882	1	Counter Balance Valve
18.	GD12239	1	O-Ring, No. 016
A.	GA10100	-	Cylinder Complete, 3" x 52" (Part Number Stamped On Barrel)
B.	GR1550	-	Seal Kit (For Cylinder And Counter Balance Valve), Includes: (1) Wiper, (1) U-Cup, (7) O-Rings, (4) BU Rings, (1) Seal, (1) Expander, (2) Cast Iron Rings

CENTER LIFT CYLINDER, 16 ROW 30"

(CYL54c/D12239)

Port Type Rephasing

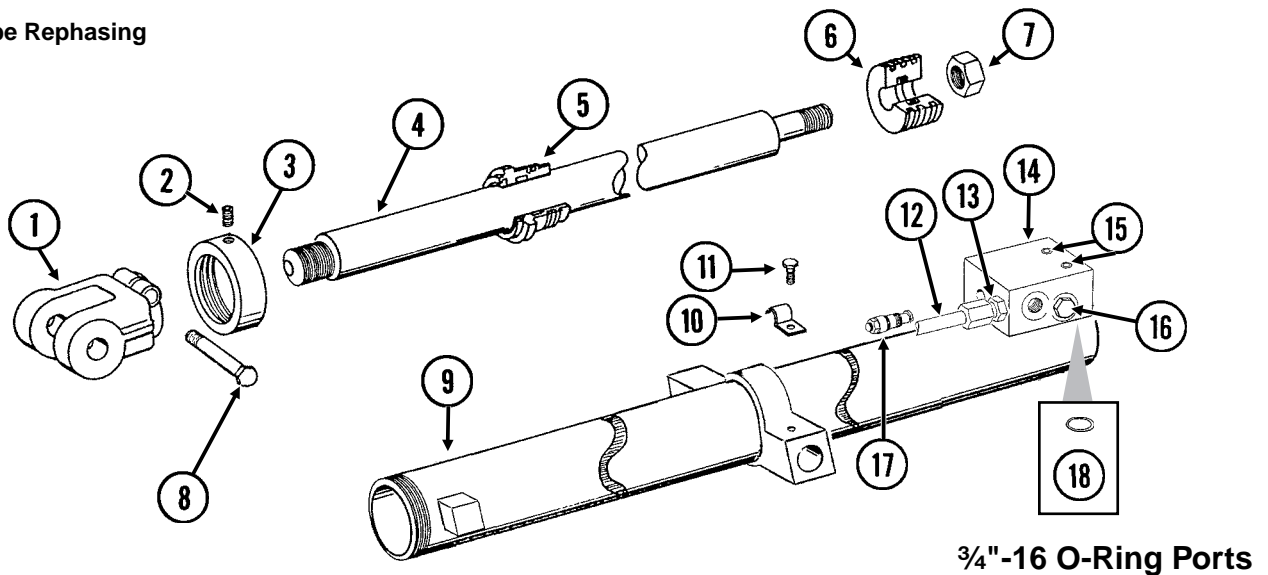

ITEM	PART NO.	QTY.	DESCRIPTION
1.	GD11951	1	Clevis
2.	G10907	1	Set Screw, 1/4"-20 x 1/4"
3.	GD13303	1	Cap
4.	GD14508	1	Rod
5.	GD13307	1	Gland
6.	GD13304	1	Piston
7.	G10958	1	Lock Nut, 1"-14
8.	G10939	1	Hex Head Cap Screw, 3/8"-16 x 2 1/4"
	G10108	1	Lock Nut, 3/8"-16
9.	GA10096	1	Barrel
10.	GD12657	1	Half Clip
11.	G10022	1	Hex Head Cap Screw, 1/4"-20 x 1/2"
	G10227	1	Lock Washer, 1/4"
12.	GA10094	1	Steel Hydraulic Line, 47 5/16"
13.	G6400-08	-	Connector W/O-Ring, 3/4"-16 Male JIC To O-Ring
	GR1037	0	O-Ring
14.	GD11579	1	Block
15.	G10932	2	Hex Socket Head Cap Screw, 5/16"-18 x 2", Grade 8
16.	G6408-08	-	Plug W/O-Ring, 3/4"-16 O-Ring
	GR1037	-	O-Ring
17.	GA8882	1	Counter Balance Valve
18.	GD12239	1	O-Ring, No. 016
A.	GA10097	-	Cylinder Complete, 3 1/4" x 52" (Part Number Stamped On Barrel)
B.	GR1572	-	Seal Kit (For Cylinder And Counter Balance Valve), Includes: (1) Wiper, (1) U-Cup, (7) O-Rings, (4) BU Rings, (1) Seal, (1) Expander, (2) Cast Iron Rings

WING LIFT CYLINDER, 12 ROW 30"

CYL031/CYL011(CYL45d)

Port Type Rephasing

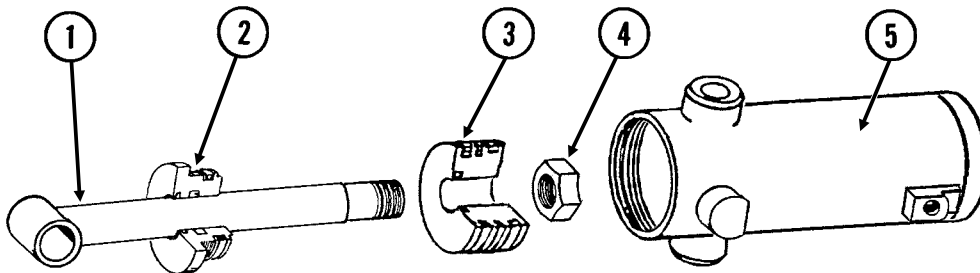

Port Type Rephasing

3/4"-16 O-Ring Ports

ITEM	PART NO.	QTY	DESCRIPTION
1.	GA8320	1	Rod Assembly W/Grease Fitting
	G10640	-	Grease Fitting, 1/4"-28
2.	GD11995	1	Gland
3.	GD11994	1	Piston
4.	G10958	1	Lock Nut, 1"-14
5.	A8797	1	Barrel (Non-Stock Item)
A.	GA8909	-	Cylinder Complete, 4 1/4" x 6" (Part Number Stamped On Barrel)
B.	GR1523	-	Seal Kit, Includes: (1) Wiper, (2) O-Rings, (1) BU Ring, (1) U-Cup, (2) Seals, (1) Piston Ring

WING LIFT CYLINDER, 16 ROW 30"

CYL031/CYL011(CYL41c)

Port Type Rephasing

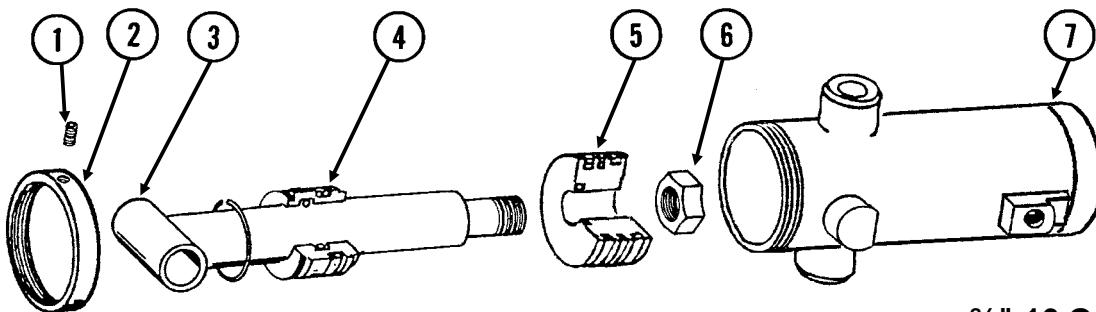

Port Type Rephasing

3/4"-16 O-Ring Ports

ITE	PART NO.	QTY	DESCRIPTION
1.	G10907	1	Set Screw, 1/4"-20 x 1/4"
2.	GD13303	1	Cap
3.	GA8157	1	Rod Assembly W/Grease Fitting
	G10449	-	Grease Fitting, 3/16", Drive-In
4.	GD13302	1	Gland
5.	GD13304	1	Piston
6.	G10958	1	Lock Nut, 1"-14
7.	A9467	1	Barrel (Non-Stock Item)
A.	GA9468	-	Cylinder Complete, 3 1/4" x 6" (Part Number Stamped On Barrel)
B.	GR1573	-	Seal Kit, Includes: (1) Expander, (2) O-Rings, (1) BU Ring, (1) Wiper, (1) U-Cup, (1) Piston Seal, (2) Cast Iron Rings

WING LOCK CYLINDERS, R.H. FRONT AND L.H. REAR

(CYL2d)

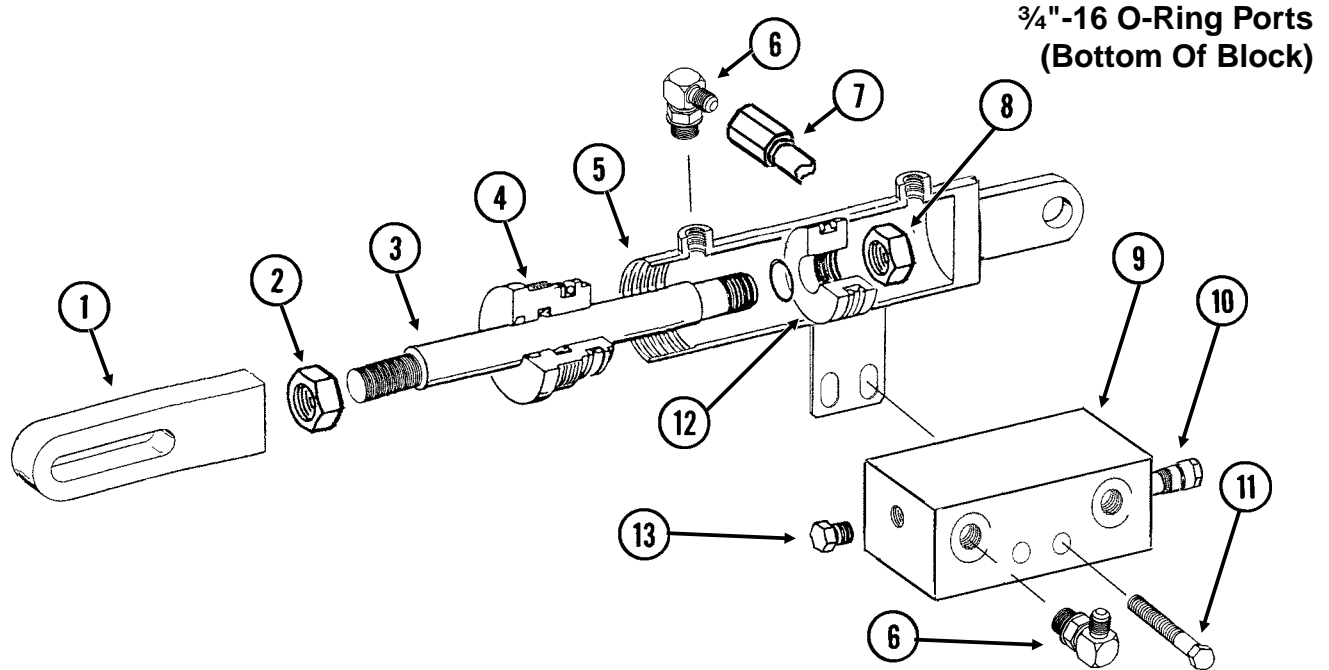

ITEM	PART NO.	QTY.	DESCRIPTION
1.	GA9013	1	Clevis
2.	G10509	1	Hex Jam Nut, 1 1/4"-12, Grade 2
3.	GD12658	1	Rod
4.	GD12659	1	Gland
5.	A9015	1	Barrel (Non-Stock Item)
6.	G6801-06-08	4	Elbow W/O-Ring, 90°, 3/16"-18 Male JIC To 3/4"-16 O-Ring
	GR1037	-	O-Ring
7.	GA9012	2	Steel Hydraulic Line, 7 9/16"
8.	G10972	1	Lock Nut, 1 1/4"-12
9.	GD12665	1	Block
10.	GA8882	1	Counter Balance Valve
11.	G10753	2	Hex Head Cap Screw, 3/8"-16 x 4 1/2"
	G10203	4	Washer, 3/8" SAE
	G10229	2	Lock Washer, 3/8"
	G10101	2	Hex Nut, 3/8"-16
12.	GD12660	1	Piston
13.	G6408-08	3	Plug W/O-Ring, 3/4"-16 O-Ring
	GR1037	-	O-Ring
A.	GA9016	-	Cylinder Complete, 4" x 3 1/2" <i>(Part Number Stamped On Barrel)</i>
B.	GR1551	-	Seal Kit (For Cylinder And Counter Balance Valve), Includes: (1) Wiper, (5) O-Rings, (4) BU Rings, (1) U-Cup, (1) T-Seal

WING LOCK CYLINDERS, L.H. FRONT AND R.H. REAR

(CYL2e)

3/4"-16 O-Ring Ports (Bottom Of Block)

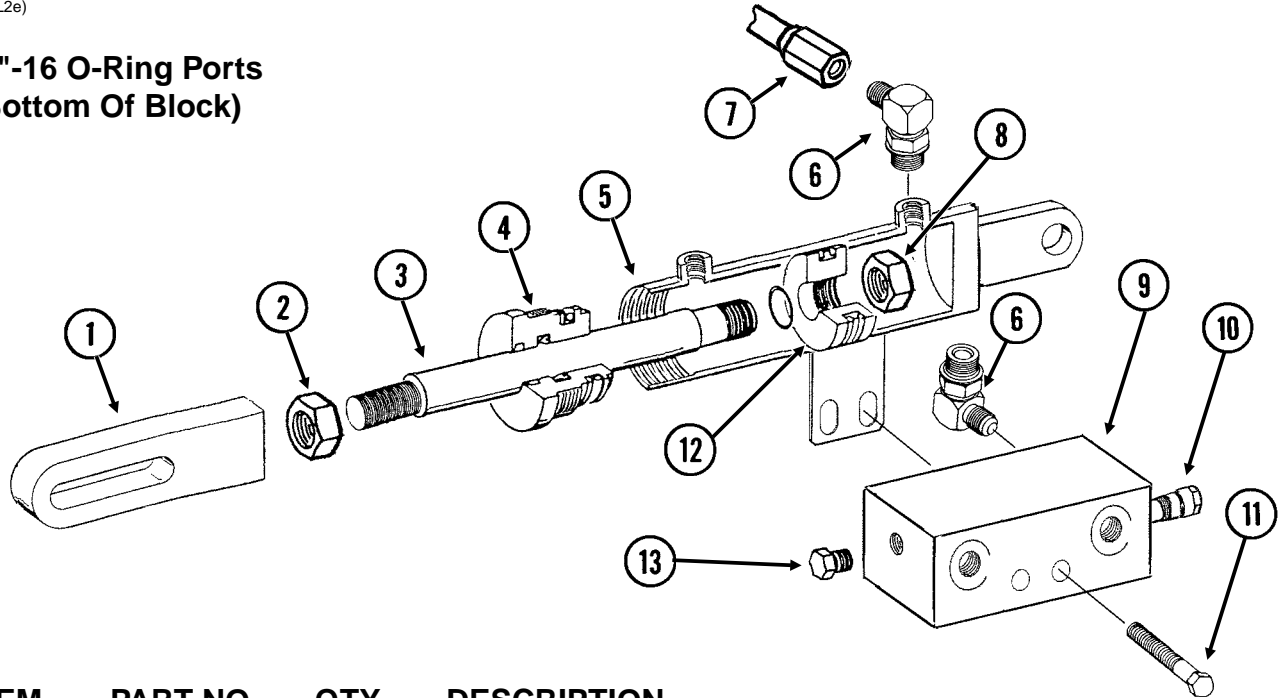

ITEM	PART NO.	QTY.	DESCRIPTION
1.	GA9013	1	Clevis
2.	G10509	1	Hex Jam Nut, 1 1/4"-12, Grade 2
3.	GD12658	1	Rod
4.	GD12659	1	Gland
5.	A9015	1	Barrel (Non-Stock Item)
6.	G6801-06-08	4	Elbow W/O-Ring, 90°, 3/16"-18 Male JIC To 3/4"-16 O-Ring
	GR1037	-	O-Ring
7.	GA9012	2	Steel Hydraulic Line, 7 9/16"
8.	G10972	1	Lock Nut, 1 1/4"-12
9.	GD12665	1	Block
10.	GA8882	1	Counter Balance Valve
11.	G10753	2	Hex Head Cap Screw, 3/8"-16 x 4 1/2"
	G10203	4	Washer, 3/8" SAE
	G10229	2	Lock Washer, 3/8"
	G10101	2	Hex Nut, 3/8"-16
12.	GD12660	1	Piston
13.	G6408-08	3	Plug W/O-Ring, 3/4"-16 O-Ring
	GR1037	-	O-Ring
A.	GA9134	-	Cylinder Complete, 4" x 3 1/2" <i>(Part Number Stamped On Barrel)</i>
B.	GR1551	-	Seal Kit (For Cylinder And Counter Balance Valve), Includes: (1) Wiper, (5) O-Rings, (4) BU Rings, (1) U-Cup, (1) T-Seal

TRANSPORT LATCH CYLINDER, ALL SIZES

CYL035/CYL050(CYL9c)

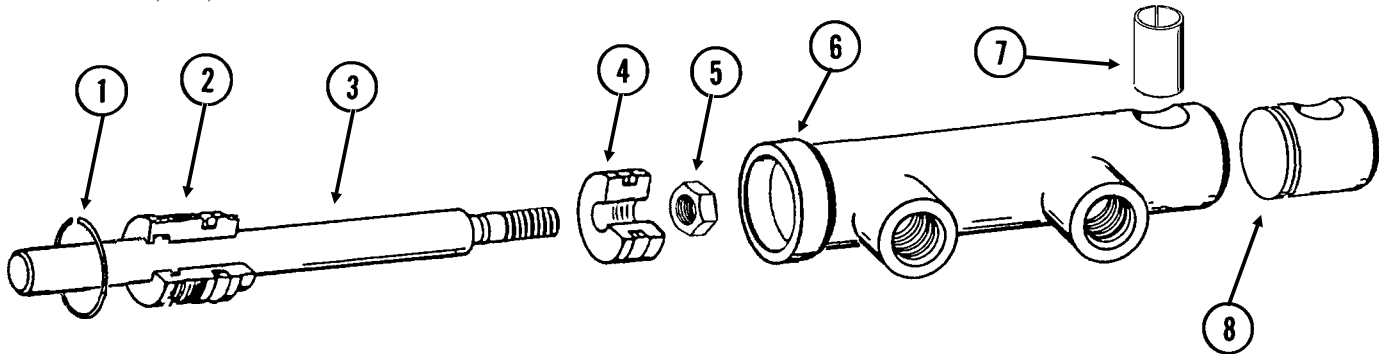

ITEM	PART NO.	QTY.	DESCRIPTION
1.	G10770	1	Internal Retaining Ring, 1 1/16"
2.	GD13170	1	Gland
3.	GD13425	1	Rod
4.	GD13172	1	Piston
5.	G11016	1	Lock Nut, 1/2"-20
6.	D13426	1	Barrel (Non-Stock Item)
7.	GD13400	1	Tension Bushing, 1" x 2" Long
8.	GD13173	1	End Cap
A.	GA9559	-	Cylinder Complete, 1 1/2" x 2 1/2" (<i>Part Number Stamped On Barrel</i>)
B.	GR1598	-	Seal Kit, Includes: (3) O-Rings, (2) BU Rings, (1) Wiper, (1) T-Seal, (1) Bronze Bushing, (1) U-Cup

TONGUE LOCK CYLINDER, ALL SIZES

CYL035(CYL9d)

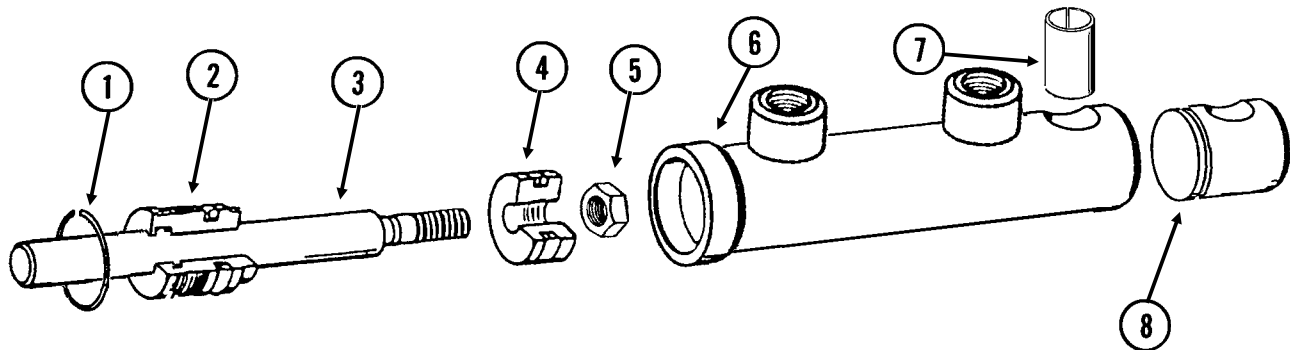

ITEM	PART NO.	QTY.	DESCRIPTION
1.	G10770	1	Internal Retaining Ring, 1 1/16"
2.	GD13170	1	Gland
3.	GD13171	1	Rod
4.	GD13172	1	Piston
5.	G11016	1	Lock Nut, 1/2"-20
6.	D13169	1	Barrel (Non-Stock Item)
7.	GD13400	1	Tension Bushing, 1" x 2" Long
8.	GD13173	1	End Cap
A.	GA9205	-	Cylinder Complete, 1 1/2" x 2 1/2" (<i>Part Number Stamped On Barrel</i>)
B.	GR1598	-	Seal Kit, Includes: (3) O-Rings, (2) BU Rings, (1) Wiper, (1) T-Seal, (1) Bronze Bushing, (1) U-Cup

TONGUE CYLINDER, 12 ROW 30"

(CYL12f)

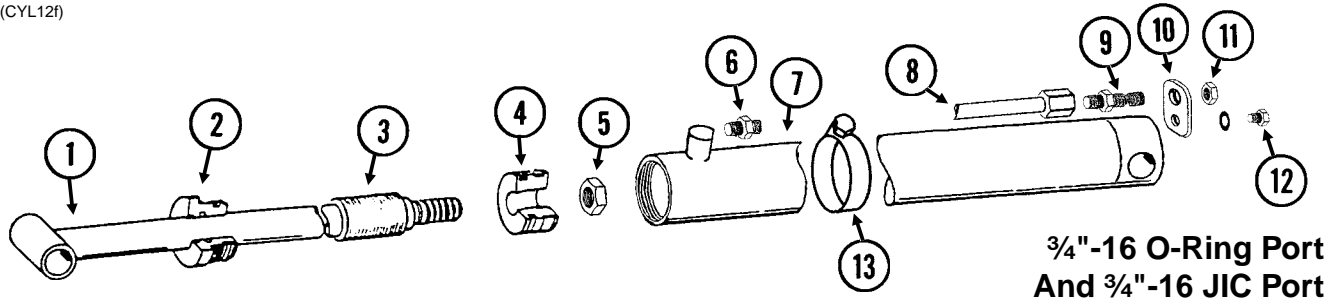

ITEM	PART NO.	QTY.	DESCRIPTION
1.	GA8893	1	Rod Assembly
2.	GD11984	1	Gland
3.	GD7147	1	Spacer
4.	GD11970	1	Piston
5.	G10972	1	Lock Nut, 1 1/4"-12
6.	G6400-08-04	1	Connector W/O-Ring, 3/4"-16 Male JIC To 7/16"-20 O-Ring
	GR1465	-	O-Ring
7.	GA8858	1	Barrel
8.	GA8978	1	Steel Hydraulic Line, 68 11/16"
9.	G2700-08	1	Bulkhead Tube Union, 3/4"-16 Male JIC
10.	GD12597	1	Bracket
11.	G306-08	1	Lock Nut, 3/4"-16
12.	G10328	1	Hex Head Cap Screw, 3/8"-16 x 5/8"
	G10229	1	Lock Washer, 3/8"
13.	G10990	1	Hose Clamp, No. 52
A.	GA8857	-	Cylinder Complete, 3" x 60" (Part Number Stamped On Barrel)
B.	GR1519	-	Seal Kit, Includes: (2) O-Rings, (1) BU Ring, (1) Wear Ring, (1) Wiper, (1) U-Cup, (1) T-Seal W/BU Rings

TONGUE CYLINDER, 16 ROW 30"

CYL036(CYL12f)

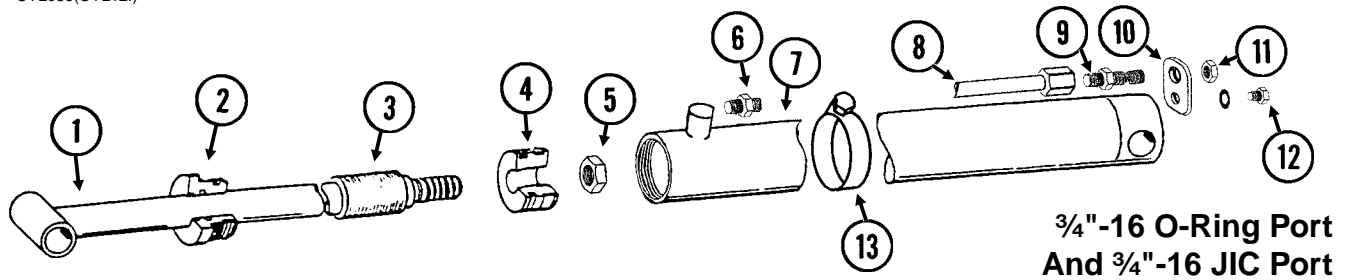

ITEM	PART NO.	QTY.	DESCRIPTION
1.	GA8859	1	Rod Assembly
2.	GD11984	1	Gland
3.	GD7147	1	Spacer
4.	GD11970	1	Piston
5.	G10972	1	Lock Nut, 1 1/4"-12
6.	G6400-08-04	1	Connector W/O-Ring, 3/4"-16 Male JIC To 7/16"-20 O-Ring
	GR1465	-	O-Ring
7.	GA8861	1	Barrel
8.	GA8979	1	Steel Hydraulic Line, 92 11/16"
9.	G2700-08	1	Bulkhead Tube Union, 3/4"-16 Male JIC
10.	GD12597	1	Bracket
11.	G306-08	1	Lock Nut, 3/4"-16
12.	G10328	1	Hex Head Cap Screw, 3/8"-16 x 5/8"
	G10229	1	Lock Washer, 3/8"
13.	G10990	1	Hose Clamp, No. 52
A.	GA8862	-	Cylinder Complete, 3" x 84" (Part Number Stamped On Barrel)
B.	GR1519	-	Seal Kit, Includes: (2) O-Rings, (1) BU Ring, (1) Wear Ring, (1) Wiper, (1) U-Cup, (1) T-Seal W/BU Rings

ROW MARKER (Cushion) CYLINDER

(CYL3d)

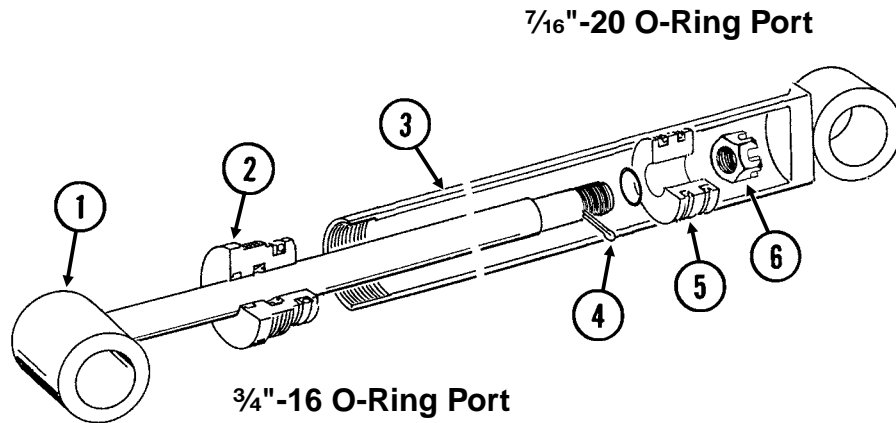

ITEM	PART NO.	QTY.	DESCRIPTION
1.	GA8871	1	Rod Assembly
2.	GD10207	1	Gland
3.	A7524	1	Barrel (Non-Stock Item)
4.	G10827	1	Cotter Pin, 1/8" x 1 3/4"
5.	GD11983	1	Piston
6.	G10962	1	Slotted Hex Nut, 7/8"-14
A.	GA8895	-	Cylinder Complete, 2 1/2" x 20 1/16" <i>(Part Number Stamped On Barrel)</i>
B.	GR1521	-	Seal Kit, Includes: (1) T-Seal, (2) O-Rings, (1) BU Ring, (1) Cast Iron Ring, (1) Wiper, (1) Lip Seal

VALVE BLOCK - LOCATED ON FRONT CENTER FRAME

VVB036(TWL24jj)

SDS ONLY

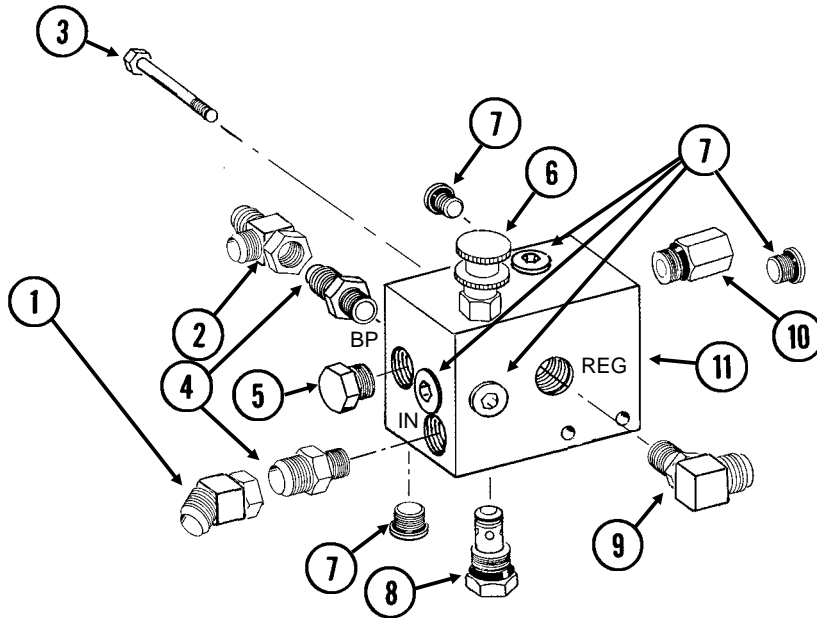

ITEM	PART NO.	QTY.	DESCRIPTION
1.	G6502-10	1	Swivel Elbow, 45°, 7/8"-14 Male JIC To Female
2.	G6602-10	1	Swivel Tee, 7/8"-14 JIC
3.	G10061	2	Hex Head Cap Screw, 3/8"-16 x 3 1/2"
	G10108	2	Lock Nut, 3/8"-16
4.	G6400-10-08	2	Connector W/O-Ring, 7/8"-14 Male JIC To 3/4"-16 O-Ring
	GR1037	-	O-Ring
5.	GR1603	1	Plug W/Stop Pin
6.		-	See "Flow Control Valve", Page P107
7.	GR1607	6	Socket Plug
8.		-	See "Check Valve", Page P107
9.	G6801-10-08	1	Elbow W/O-Ring, 90°, 7/8"-14 Male JIC To 3/4"-16 O-Ring
	GR1037	-	O-Ring
10.		-	See "Pressure Relief Valve", Page P107
11.		-	Block (Non-Stock Item)
A.	GR1609	-	Seal Kit, Includes: (12) O-Rings, (2) BU Rings
B.	GA9128	-	Valve Block Assembly (Items 5-8, 10 And 11)

VALVE BLOCK - LOCATED ON FRONT CENTER FRAME

VVB036(TWL241)

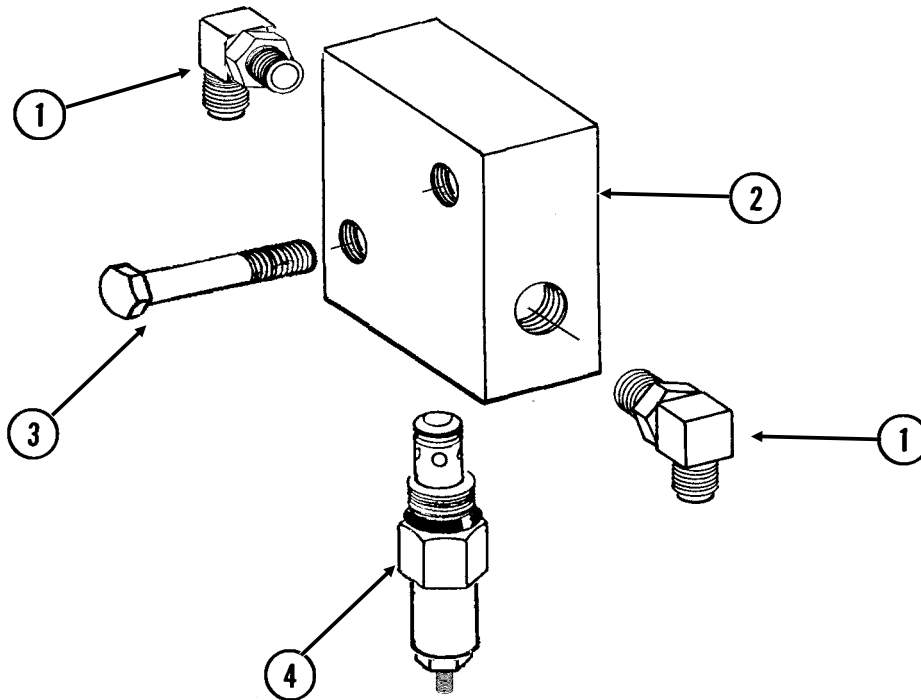

ITEM	PART NO.	QTY.	DESCRIPTION
1.	G6801-08 GR1037	2 -	Elbow W/O-Ring, 90°, 3/4"-16 Male JIC To O-Ring O-Ring
2.	GD14528	-	Valve Block
3.	G10069 G10232 G10106	2 2 2	Hex Head Cap Screw, 5/16"-18 x 2 1/4" Lock Washer, 5/16" Hex Nut, 5/16"-18
4.		-	See "Pressure Relief Valve", Page P108

VALVE BLOCK - LOCATED ON R.H. SIDE OF CENTER PIVOT

VVB036(TWL208a)

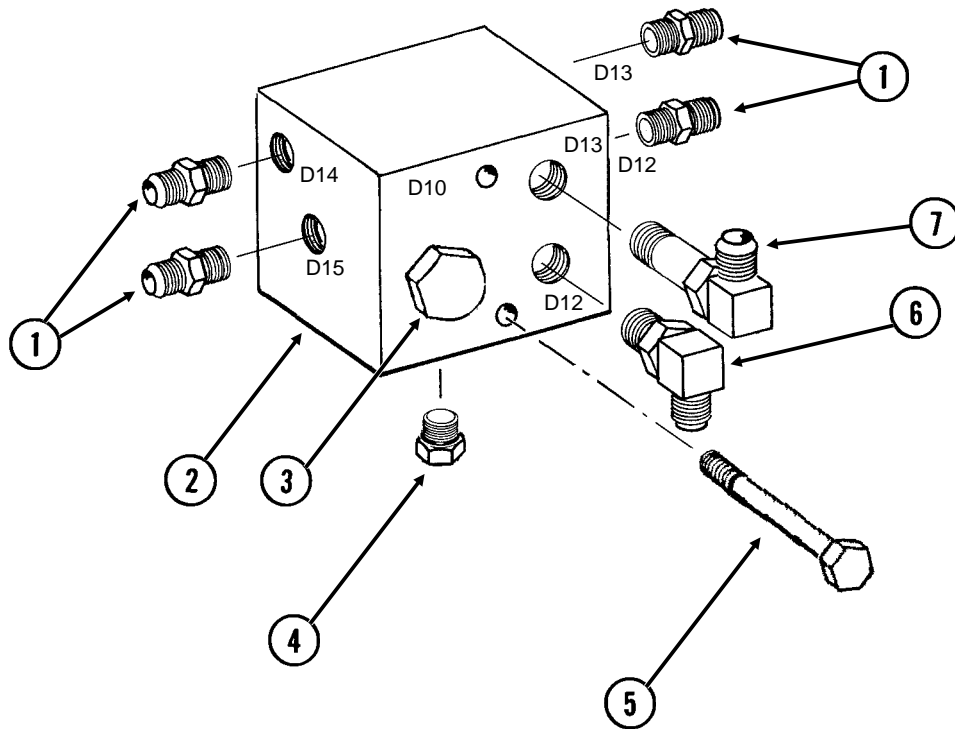

ITEM	PART NO.	QTY.	DESCRIPTION
1.	G6400-08 GR1037	4 -	Connector W/O-Ring, 3/4"-16 Male JIC To O-Ring O-Ring
2.	GD12758	1	Block
3.		-	See "Pilot Operated Check Valve", Page P109
4.	G6408-08 GR1037	1 -	Plug W/O-Ring, 3/4"-16 O-Ring O-Ring
5.	G10753 G10108	2 2	Hex Head Cap Screw, 3/8"-16 x 4 1/2" Lock Nut, 3/8"-16
6.	G6801-08 GR1037	1 -	Elbow W/O-Ring, 90°, 3/4"-16 Male JIC To O-Ring O-Ring
7.	G6801-LL-08 GR1037	1 -	X-Long Elbow W/O-Ring, 90°, 3/4"-16 Male JIC To O-Ring O-Ring

VALVE BLOCKS - LOCATED ON REAR CENTER FRAME

VVB034(TWL25d)

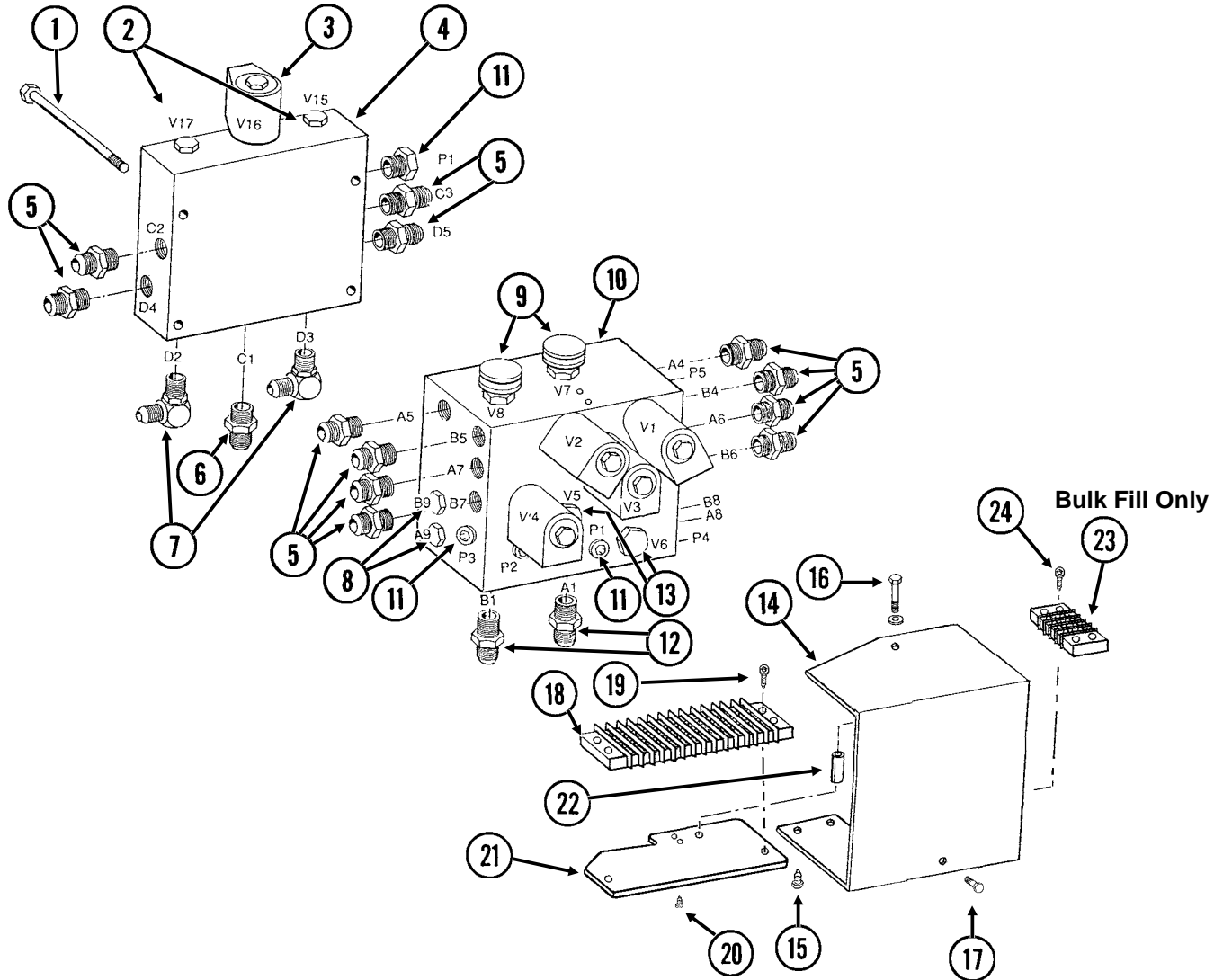

VALVE BLOCKS - LOCATED ON REAR CENTER FRAME

ITEM	PART NO.	QTY.	DESCRIPTION
1.	G10583	4	Hex Head Cap Screw, 5/16"-18 x 2 3/4"
	G10232	4	Lock Washer, 5/16"
2.		2	See "Check Valve", Page P109
3.		5	See "Solenoid Valve", Page P108
4.	GD9977	1	Block
5.	G6400-08	12	Connector W/O-Ring, 3/4"-16 Male JIC To O-Ring
	GR1037	-	O-Ring
6.	G6400-10	1	Connector W/O-Ring, 7/8"-14 Male JIC To O-Ring
	GR1466	-	O-Ring
7.	G6801-08-10	2	Elbow W/O-Ring, 90°, 3/4"-16 Male JIC To 7/8"-14 O-Ring
	GR1466	-	O-Ring
8.	G6408-08	4	Plug W/O-Ring, 3/4"-16 O-Ring
	GR1037	-	O-Ring
9.		2	See "Flow Control Valve", Page P108
10.	GD9533	1	Block
11.	G6408-H06-O	6	Hex Socket Head Plug W/O-Ring, 9/16"-18 O-Ring
	GR1045	-	O-Ring
12.	G6400-08-10	2	Connector W/O-Ring, 3/4"-16 Male JIC To 7/8"-14 O-Ring
	GR1466	-	O-Ring
13.	G6408-10	2	Plug W/O-Ring, 7/8"-14 O-Ring
	GR1466	-	O-Ring
14.	GD13146	1	Cover
15.	G10977	2	Phillips Pan Head Machine Screw, No. 10-24 x 1/2", Stainless Steel
16.	G10133	1	Hex Head Cap Screw, 5/16"-18 x 1 1/2"
	G10232	1	Lock Washer, 5/16"
17.	G10054	1	Hex Head Cap Screw, 5/16"-18 x 1/2"
	G10232	1	Lock Washer, 5/16"
	G10106	1	Hex Nut, 5/16"-18
18.	GA9097	1	Terminal Strip W/Screws, No. 6, 14 Terminal
	GR1635	-	Screw, No. 6-32 x 1/4"
19.	G11067	2	Phillips Pan Head Machine Screw, No. 8-32 x 3/4", Stainless Steel
20.	G11066	2	Phillips Pan Head Machine Screw, No. 10-24 x 3/4", Stainless Steel
21.	GA9095	1	Terminal Strip Mount
22.	GD8066-02	1	Sleeve, 1" Long
23.	GA9510	1	Terminal Strip W/Screws, No. 6, 4 Terminal
	GR1635	-	Screw, No. 6-32 x 1/4"
24.	G11067	2	Phillips Pan Head Machine Screw, No. 8-32 x 3/4", Stainless Steel
	G10928	2	Hex Nut, No. 8-32, Stainless Steel

VALVE BLOCK - LOCATED ON HITCH

VVB035(TWL26f)

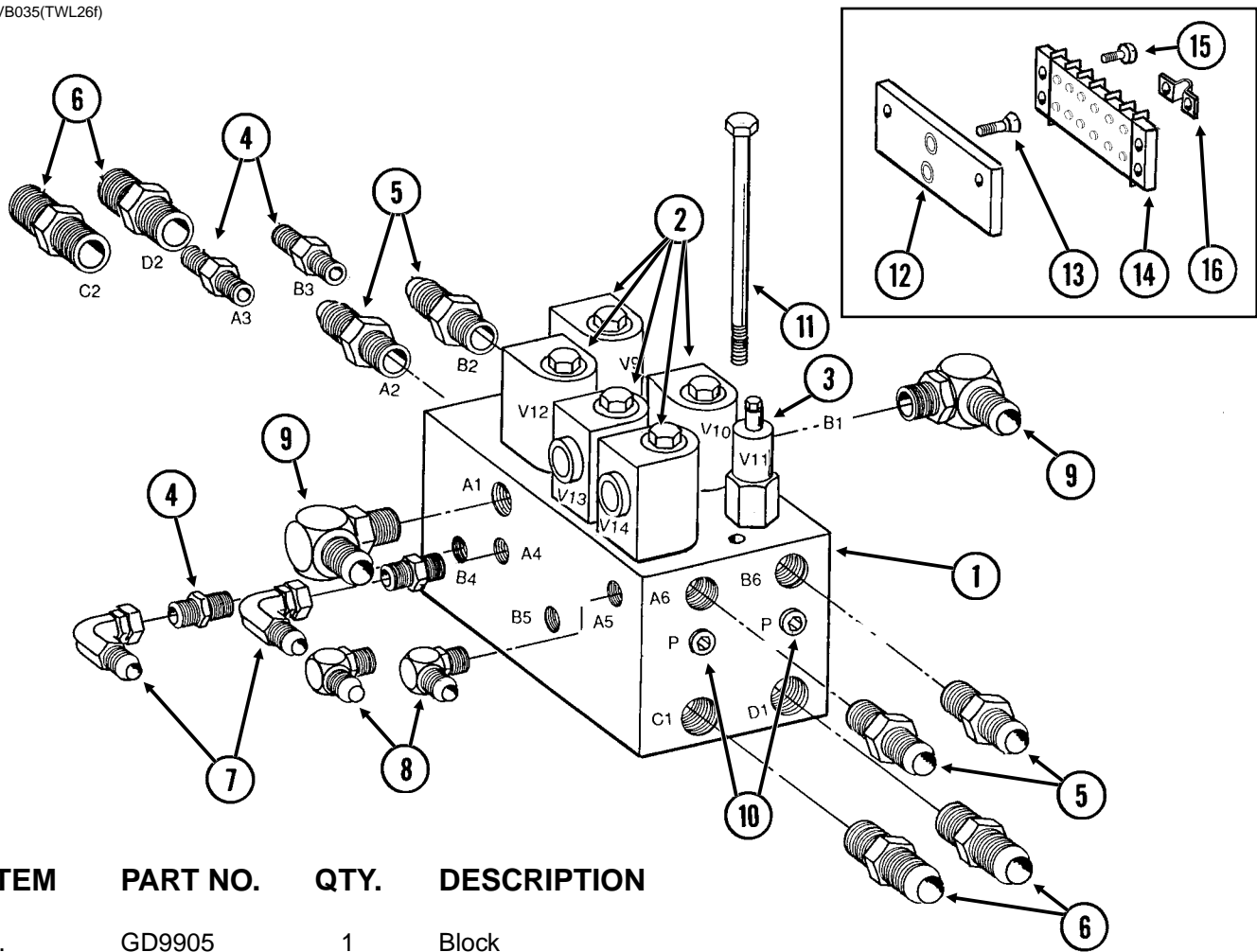

ITEM	PART NO.	QTY.	DESCRIPTION
1.	GD9905	1	Block
2.		-	See "Solenoid Valve", Page P108
3.		-	See "Pressure Relief Valve", Page P108
4.	G6400-06 GR1045	4	Connector W/O-Ring, 1/16"-18 Male JIC To O-Ring O-Ring
5.	G6400-08 GR1037	4	Connector W/O-Ring, 1/4"-16 Male JIC To O-Ring O-Ring
6.	G6400-10 GR1466	4	Connector W/O-Ring, 7/8"-14 Male JIC To O-Ring O-Ring
7.	G6500-06	2	Swivel Elbow, 90°, 1/16"-18 Male JIC To Female
8.	G6801-06 GR1045	2	Elbow W/O-Ring, 90°, 1/16"-18 Male JIC To O-Ring O-Ring
9.	G6801-08 GR1037	2	Elbow W/O-Ring, 90°, 1/4"-16 Male JIC To O-Ring O-Ring
10.	G6408-H06-O GR1045	2	Hex Socket Head Plug W/O-Ring, 1/16"-18 O-Ring O-Ring
11.		-	See "Hose Take-Up", Pages P64 And P65
12.	GD12818	-	Terminal Strip Mount
13.	G11068	2	Phillips Flat Head Machine Screw, No. 10-24 x 5/8", Stainless Steel
14.	GA9098 GR1635	-	Terminal Strip W/Screws, No. 6, 8 Terminal Screw, No. 6-32 x 1/4"
15.	G11065	2	Phillips Pan Head Machine Screw, No. 8-32 x 5/8", Stainless Steel
16.		-	See "Electrical Components", Pages P118-P121

FLOW CONTROL VALVE (Located In Valve Block On Front Center Frame)

(TWL28a)

SDS ONLY

ITEM	PART NO.	QTY.	DESCRIPTION
A.	GR1601	-	Flow Control Valve
B.	GR1610	-	Seal Kit, Includes: (2) O-Rings, (1) BU Ring

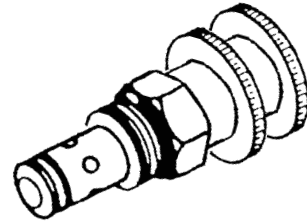

PRESSURE RELIEF VALVE (Located In Valve Block On Front Center Frame)

(TWL24c)

SDS ONLY

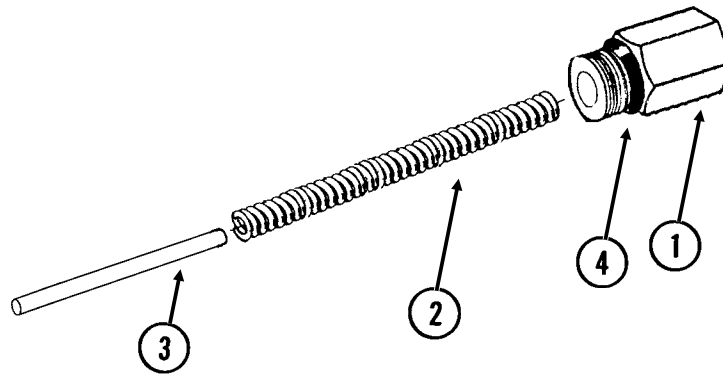

ITEM	PART NO.	QTY.	DESCRIPTION
1.	GR1604	1	Cap
2.	GR1605	1	Compression Spring
3.	GR1606	1	Spring Guide
4.	GR1608	2	O-Ring

CHECK VALVE (Located In Valve Block On Front Center Frame)

(TWL24b)

SDS ONLY

ITEM	PART NO.	QTY.	DESCRIPTION
A.	GR1602	-	Check Cartridge
B.	GR1610	-	Seal Kit, Includes: (2) O-Rings, (1) BU Ring

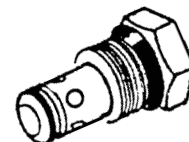

SOLENOID VALVE

VVB019(TWL27c/TWL18/PLTR75c/A9481)

ITEM	PART NO.	QTY.	DESCRIPTION
1.	GR0761	1	Special Hex Nut, 1/2"-20
2.	G1K274	1	Coil Kit W/Contacts, Housings And Fork Terminals
	GD9529	2	Housing, Black
	GD9530	2	Contact
	G10996	2	Fork Terminal
3.	GR0763	1	Cartridge
A.	G1K275	-	Solenoid Valve Kit W/Contacts, Housings And Fork Terminals
	GD9529	2	Housing, Black
	GD9530	2	Contact
	G10996	2	Fork Terminal
B.	GR0764	-	Seal Kit, Includes: (2) O-Rings, (1) BU Ring

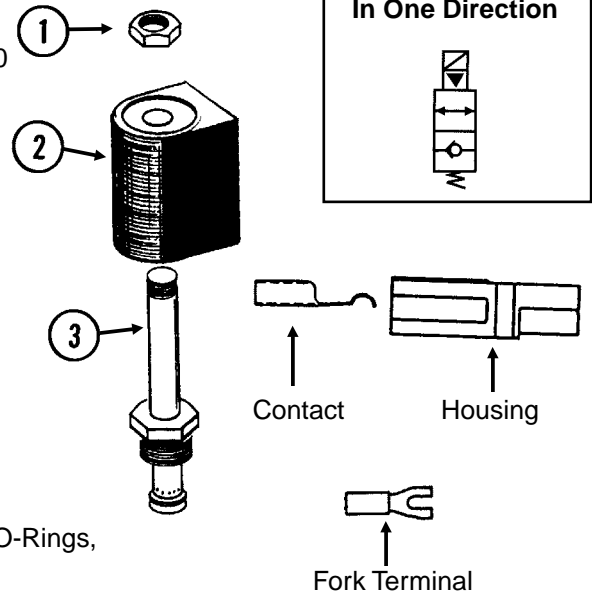

FLOW CONTROL VALVE (Located In Valve Block On Rear Center Frame)

VVB020(TWL28)

ITEM	PART NO.	QTY.	DESCRIPTION
A.	GA3413	-	Flow Control Valve
B.	GR0764	-	Seal Kit, Includes: (2) O-Rings, (1) BU Ring

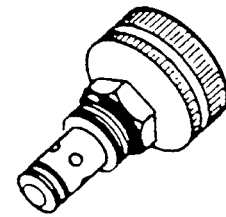

PRESSURE RELIEF VALVE (Located In Valve Block On Hitch And In Valve Block On Front Center Frame)

VVB020(TWL29)

ITEM	PART NO.	QTY.	DESCRIPTION
A.	GA3407	-	Pressure Relief Valve, 1000 PSI
B.	GR0764	-	Seal Kit, Includes: (2) O-Rings, (1) BU Ring

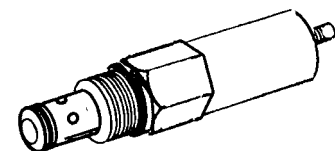

CHECK VALVE (Located In Valve Block On Rear Center Frame)

VVB020(TWL30)

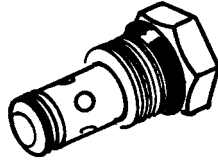

ITEM	PART NO.	QTY.	DESCRIPTION
A.	GA4293	-	Check Valve
B.	GR0764	-	Seal Kit, Includes: (2) O-Rings, (1) BU Ring

PILOT OPERATED CHECK VALVE (Located In Valve Block On R.H. Side Of Front Center Frame)

VVB020(TWL30b)

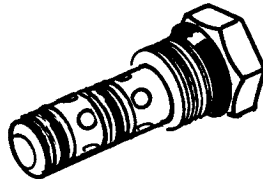

ITEM	PART NO.	QTY.	DESCRIPTION
A.	GA9126	-	Pilot Operated Check Valve
B.	GR1627	-	Seal Kit, Includes: (3) O-Rings, (4) BU Rings

HYDRAULIC HOSES AND FITTINGS ON HITCH

(A10125b/A10125aa)

SDS Planters

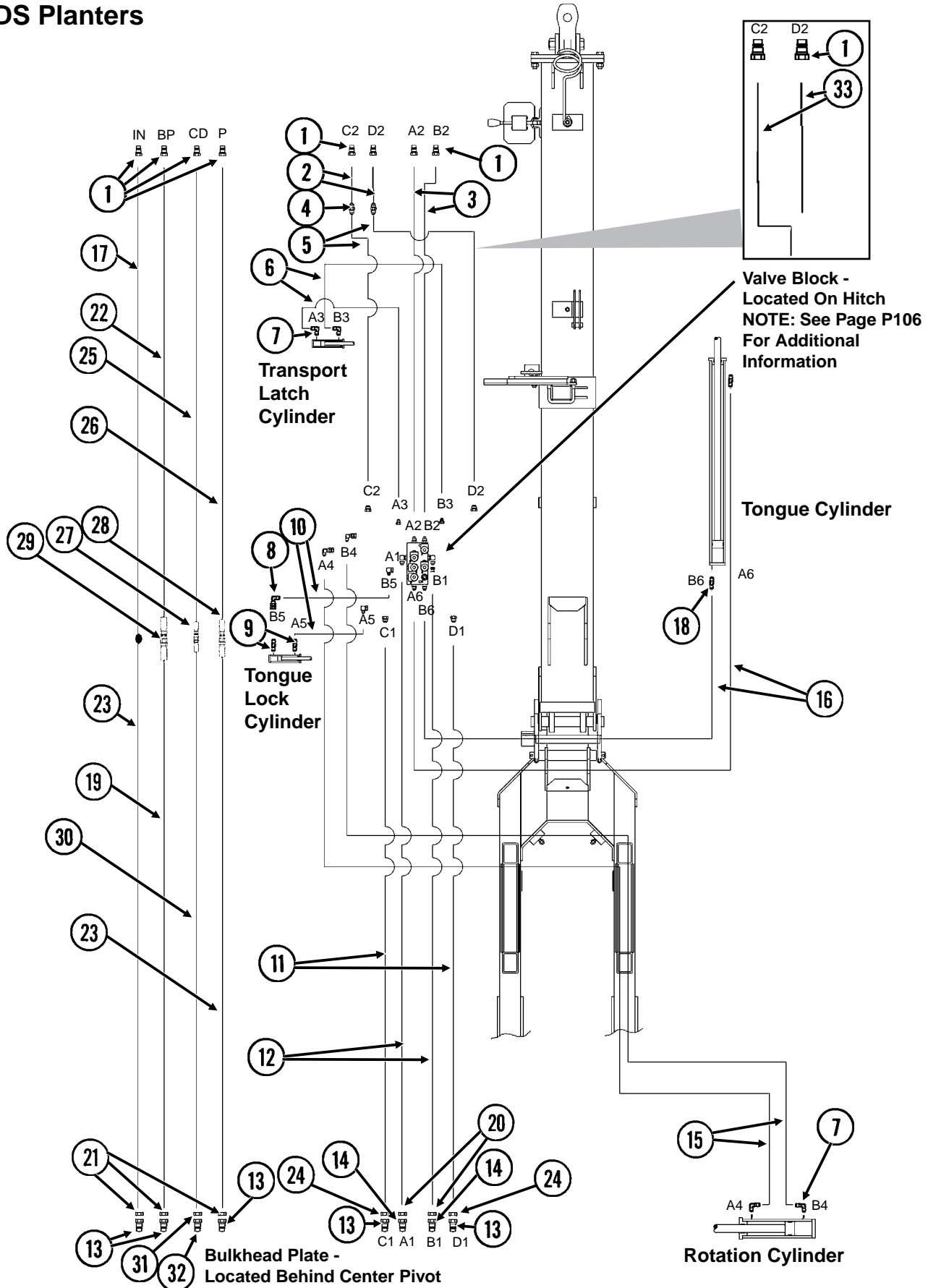

HYDRAULIC HOSES AND FITTINGS ON HITCH

ITEM	PART NO.	QTY.	DESCRIPTION
1.	GD4086	8	ISO Coupler
2.	*A8206	2	Hose Assembly, 1/2" x 147", 12 Row 30"
	*A8200	-	Hose Assembly, 1/2" x 178", 16 Row 30"
3.	*A3133	2	Hose Assembly, 3/8" x 191", 12 Row 30"
	*A3183	-	Hose Assembly, 3/8" x 246", 16 Row 30"
4.	G2403-10	2	Union, 7/8"-14 Male JIC
5.	*A8203	2	Hose Assembly, 1/2" x 43", 12 Row 30"
	*A1463	-	Hose Assembly, 1/2" x 68", 16 Row 30"
6.	*A7603	2	Hose Assembly, 1/4" x 112", 12 Row 30"
	*A1129	-	Hose Assembly, 1/4" x 168", 16 Row 30"
7.	G6801-06-08	4	Elbow W/O-Ring, 90°, 9/16"-18 Male JIC To 3/4"-16 O-Ring
	GR1037	-	O-Ring
8.	G6502-06	1	Swivel Elbow, 45°, 9/16"-18 Male JIC To Female
9.	G6400-06-08	2	Connector W/O-Ring, 9/16"-18 Male JIC To 3/4"-16 O-Ring
	GR1037	-	O-Ring
10.	*A1139	2	Hose Assembly, 1/4" x 40"
11.	*A8217	2	Hose Assembly, 1/2" x 133", 12 Row 30"
	*A8218	-	Hose Assembly, 1/2" x 139", 16 Row 30"
12.	*A3199	2	Hose Assembly, 3/8" x 132", 12 Row 30"
	*A3137	-	Hose Assembly, 3/8" x 140", 16 Row 30"
13.	G2700-10	5	Bulkhead Tube Union, 7/8"-14 Male JIC
14.	G2700-08	2	Bulkhead Tube Union, 3/4"-16 Male JIC
15.	*A7609	2	Hose Assembly, 1/4" x 164", 12 Row 30"
	*A1184	-	Hose Assembly, 1/4" x 173", 16 Row 30"
16.	*A3156	2	Hose Assembly, 3/8" x 68", 12 Row 30"
	*A3118	-	Hose Assembly, 3/8" x 80", 16 Row 30"
17.	*A8220	1	Hose Assembly, 1/2" x 198", 12 Row 30"
	*A8219	-	Hose Assembly, 1/2" x 250", 16 Row 30"
18.	G6400-08	1	Connector W/O-Ring, 3/4"-16 Male JIC To O-Ring
	GR1037	-	O-Ring
19.	*A3343	1	Hose Assembly, 3/4" x 144"
20.	G306-08	2	Lock Nut, 3/4"-16
21.	G306-10	3	Lock Nut, 7/8"-14
22.	*A3341	1	Hose Assembly, 3/4" x 198", 12 Row 30"
	*A3342	-	Hose Assembly, 3/4" x 250", 16 Row 30"
23.	*A8216	2	Hose Assembly, 1/2" x 144"
24.	G306-10	2	Lock Nut, 7/8"-14
25.	*A12030	1	Hose Assembly, 3/8" x 198", 12 Row 30"
	*A12029	-	Hose Assembly, 3/8" x 250", 16 Row 30"
26.	*A1477	1	Hose Assembly, 1/2" x 198", 12 Row 30"
	*A1444	-	Hose Assembly, 1/2" x 250", 16 Row 30"
27.	G2403-06	1	Union, 9/16"-18 Male JIC
28.	G2403-10	1	Union, 7/8"-14 Male JIC
29.	G2403-12	1	Union, 1 1/16"-12 Male JIC
30.	*A12028	1	Hose Assembly, 3/8" x 145"
31.	G306-06	1	Lock Nut, 9/16"-18
32.	G2700-06-06	1	Bulkhead Tube Union, 9/16"-18 Male JIC
33.	*A1489	2	Hose Assembly, 1/2" x 191", 12 Row 30"
	*A1491	-	Hose Assembly, 1/2" x 246", 16 Row 30"

* Hydraulic hose is not stocked by KINZE® Repair Parts, but can be made available on a special order basis. Call for quote.

HYDRAULIC HOSES AND FITTINGS ON HITCH

(A10125c/A10125aa)

Conventional Planters

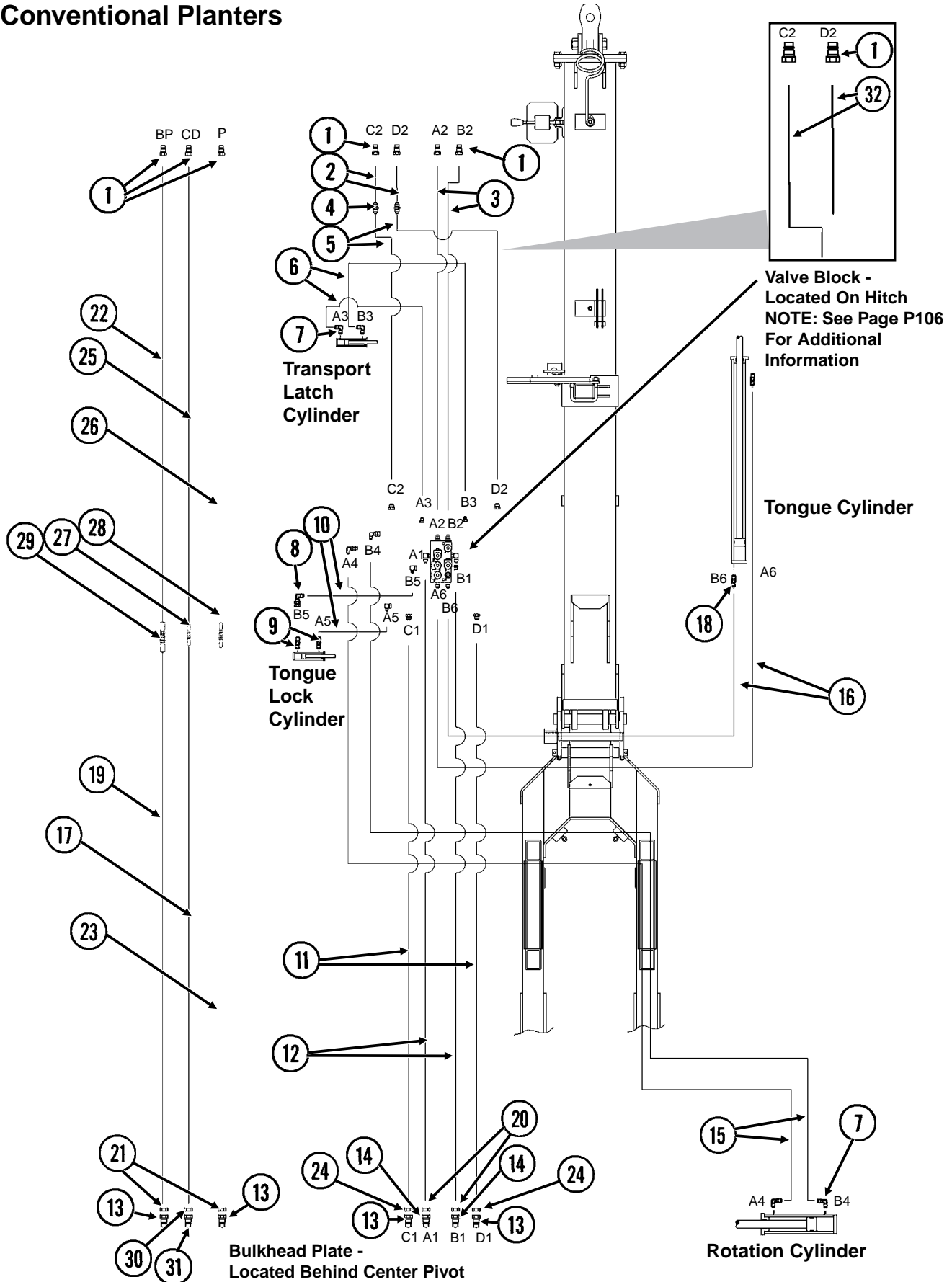

HYDRAULIC HOSES AND FITTINGS ON HITCH

ITEM	PART NO.	QTY.	DESCRIPTION
1.	GD4086	7	ISO Coupler
2.	*A8206	2	Hose Assembly, 1/2" x 147", 12 Row 30"
	*A8200	-	Hose Assembly, 1/2" x 178", 16 Row 30"
3.	*A3133	2	Hose Assembly, 3/8" x 191", 12 Row 30"
	*A3183	-	Hose Assembly, 3/8" x 246", 16 Row 30"
4.	G2403-10	2	Union, 7/8"-14 Male JIC
5.	*A8203	2	Hose Assembly, 1/2" x 43", 12 Row 30"
	*A1463	-	Hose Assembly, 1/2" x 68", 16 Row 30"
6.	*A7603	2	Hose Assembly, 1/4" x 112", 12 Row 30"
	*A1129	-	Hose Assembly, 1/4" x 168", 16 Row 30"
7.	G6801-06-08	4	Elbow W/O-Ring, 90°, 9/16"-18 Male JIC To 3/4"-16 O-Ring
	GR1037	-	O-Ring
8.	G6502-06	1	Swivel Elbow, 45°, 9/16"-18 Male JIC To Female
9.	G6400-06-08	2	Connector W/O-Ring, 9/16"-18 Male JIC To 3/4"-16 O-Ring
	GR1037	-	O-Ring
10.	*A1139	2	Hose Assembly, 1/4" x 40"
11.	*A8217	2	Hose Assembly, 1/2" x 133", 12 Row 30"
	*A8218	-	Hose Assembly, 1/2" x 139", 16 Row 30"
12.	*A3199	2	Hose Assembly, 3/8" x 132", 12 Row 30"
	*A3137	-	Hose Assembly, 3/8" x 140", 16 Row 30"
13.	G2700-10	4	Bulkhead Tube Union, 7/8"-14 Male JIC
14.	G2700-08	2	Bulkhead Tube Union, 3/4"-16 Male JIC
15.	*A7609	2	Hose Assembly, 1/4" x 164", 12 Row 30"
	*A1184	-	Hose Assembly, 1/4" x 173", 16 Row 30"
16.	*A3156	2	Hose Assembly, 3/8" x 68", 12 Row 30"
	*A3118	-	Hose Assembly, 3/8" x 80", 16 Row 30"
17.	*A12028	1	Hose Assembly, 3/8" x 145"
18.	G6400-08	1	Connector W/O-Ring, 3/4"-16 Male JIC To O-Ring
	GR1037	-	O-Ring
19.	*A3343	1	Hose Assembly, 3/4" x 144"
20.	G306-08	2	Lock Nut, 3/4"-16
21.	G306-10	2	Lock Nut, 7/8"-14
22.	*A3341	1	Hose Assembly, 3/4" x 198", 12 Row 30"
	*A3342	-	Hose Assembly, 3/4" x 250", 16 Row 30"
23.	*A8216	1	Hose Assembly, 1/2" x 144"
24.	G306-10	2	Lock Nut, 7/8"-14
25.	*A12030	1	Hose Assembly, 3/8" x 198", 12 Row 30"
	*A12029	-	Hose Assembly, 3/8" x 250", 16 Row 30"
26.	*A1477	1	Hose Assembly, 1/2" x 198", 12 Row 30"
	*A1444	-	Hose Assembly, 1/2" x 250", 16 Row 30"
27.	G2403-06	1	Union, 9/16"-18 Male JIC
28.	G2403-10	1	Union, 7/8"-14 Male JIC
29.	G2403-12	1	Union, 1 1/16"-12 Male JIC
30.	G306-06	1	Lock Nut, 9/16"-18
31.	G2700-06-06	1	Bulkhead Tube Union, 9/16"-18 Male JIC
32.	*A1489	2	Hose Assembly, 1/2" x 191", 12 Row 30"
	*A1491	-	Hose Assembly, 1/2" x 246", 16 Row 30"

* Hydraulic hose is not stocked by KINZE® Repair Parts, but can be made available on a special order basis. Call for quote.

HYDRAULIC HOSES AND FITTINGS ON PLANTER FRAME

(TWL207gg/TWL207eee)

16 Row 30" Shown (Two Wing Lift Cylinders Per Wing)
 12 Row 30" (One Wing Lift Cylinder Per Wing)

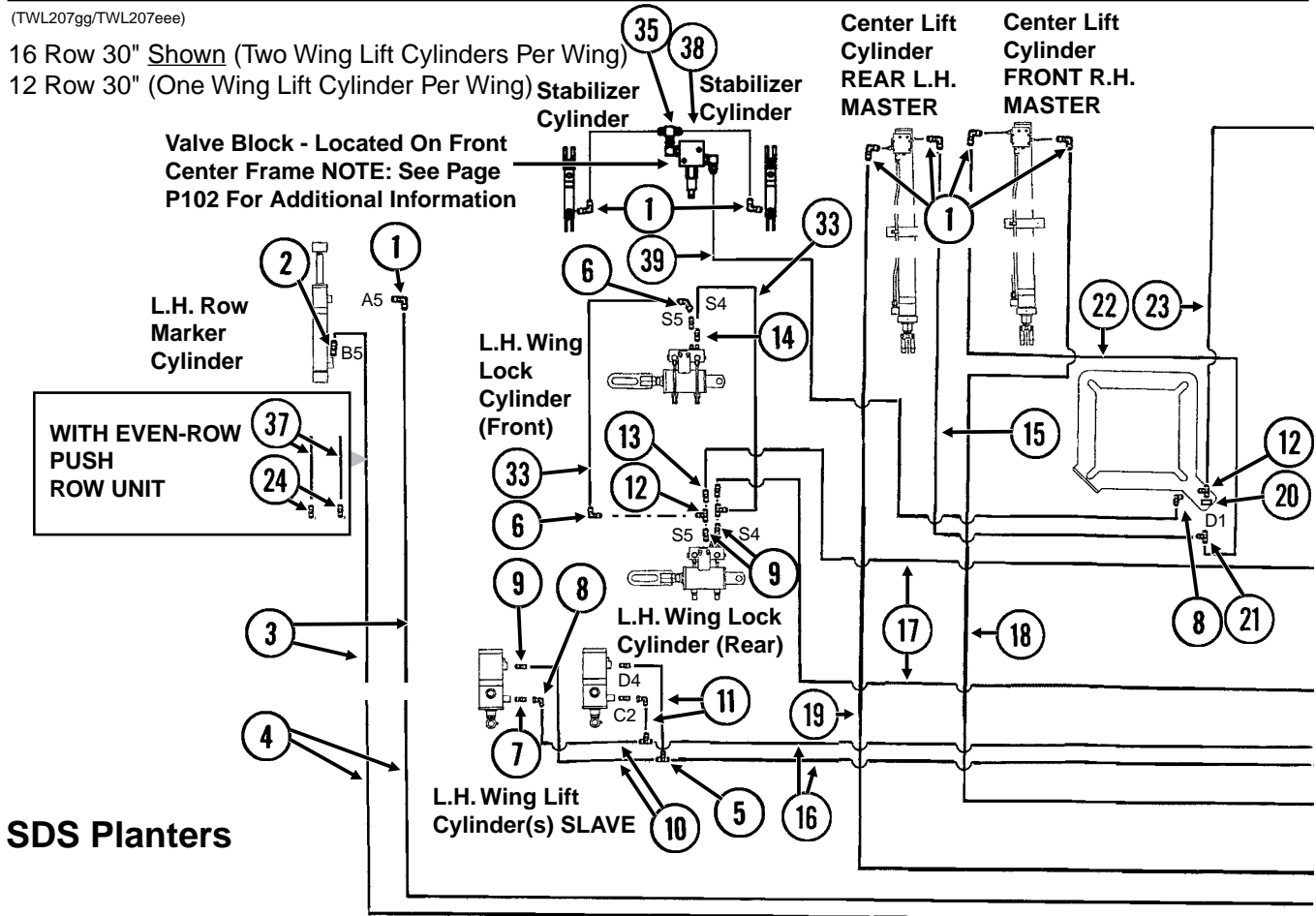

SDS Planters

ITEM	PART NO.	QTY.	DESCRIPTION
1.	G6801-08 GR1037	8 -	Elbow W/O-Ring, 90°, 3/4"-16 Male JIC To O-Ring O-Ring
2.	G6400-08-04 GR1465	2 -	Connector W/O-Ring, 3/4"-16 Male JIC To 7/16"-20 O-Ring O-Ring
3.	*A3220	4	Hose Assembly, 3/8" x 82", 12 Row 30"
	*A3219	-	Hose Assembly, 3/8" x 104", 16 Row 30"
4.	*A3101	4	Hose Assembly, 3/8" x 168", 12 Row 30"
	*A3161	-	Hose Assembly, 3/8" x 210", 16 Row 30"
5.	G2603-08	4	Tee, 3/4"-16 Male JIC
6.	G6502-08	11	Swivel Elbow, 45°, 3/4"-16 Male JIC To Female
7.	G6400-L-08 GR1037	2-4 -	Long Connector W/O-Ring, 3/4"-16 Male JIC To O-Ring O-Ring
8.	G6500-08	3-5	Swivel Elbow, 90°, 3/4"-16 Male JIC To Female
9.	G6400-08 GR1037	6-8 -	Connector W/O-Ring, 3/4"-16 Male JIC To O-Ring O-Ring
10.	*A1018	4	Hose Assembly, 3/8" x 40"
11.	*A3218	4	Hose Assembly, 3/8" x 8"
12.	G6602-08	5	Swivel Tee, 3/4"-16 JIC
13.	G2406-08-06	4	Reducer, 3/4"-16 Female JIC To 1/16"-18 Male JIC
14.	G6400-06-08 GR1037	4 -	Connector W/O-Ring, 1/16"-18 Male JIC To 3/4"-16 O-Ring O-Ring
15.	*A1098	3	Hose Assembly, 3/8" x 26"
16.	*A1054	4	Hose Assembly, 3/8" x 204", 12 Row 30"
	*A3163	-	Hose Assembly, 3/8" x 225", 16 Row 30"
17.	*A1008	2	Hose Assembly, 3/8" x 110"
18.	*A1021	1	Hose Assembly, 3/8" x 56"
19.	*A3128	1	Hose Assembly, 3/8" x 52"
20.	G306-08	1	Lock Nut, 3/4"-16
21.	G2704-08	1	Bulkhead Tee, 3/4"-16 JIC
22.	*A1044	1	Hose Assembly, 3/8" x 34"
23.	*A8222	1	Hose Assembly, 1/2" x 91"
24.	G2403-08	2	Union, 3/4"-16 Male JIC

HYDRAULIC HOSES AND FITTINGS ON PLANTER FRAME

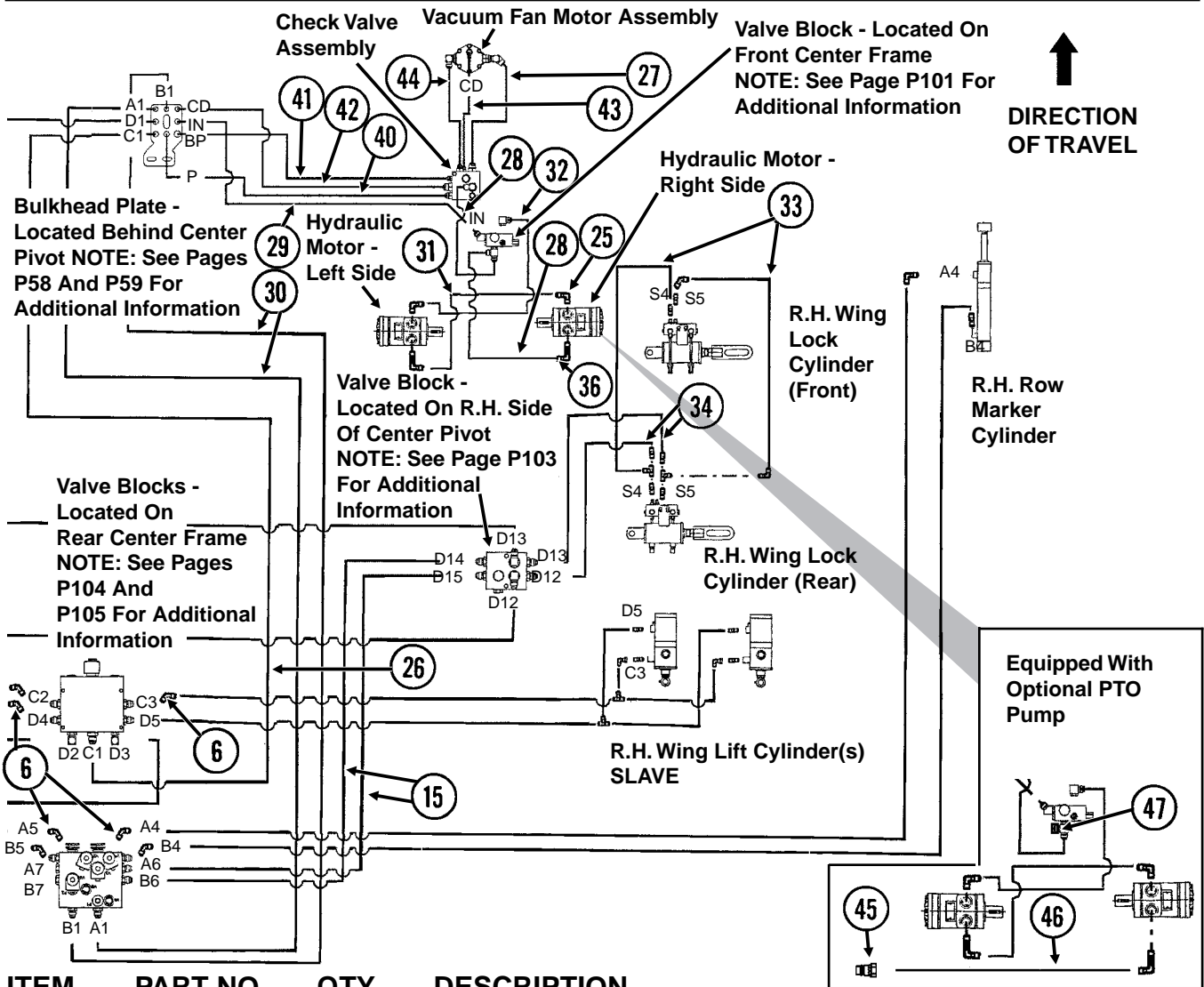

ITEM	PART NO.	QTY.	DESCRIPTION
25.	G6801-10 GR1466	2 -	Elbow W/O-Ring, 90°, 7/8"-14 Male JIC To O-Ring O-Ring
26.	*A8221	1	Hose Assembly, 1/2" x 76"
27.	*A3366	1	Hose Assembly, 3/4" x 18"
28.	*A1450	2	Hose Assembly, 1/2" x 22"
29.	*A8223	1	Hose Assembly, 1/2" x 111"
30.	*A1039	2	Hose Assembly, 3/8" x 76"
31.	*A1457	1	Hose Assembly, 1/2" x 51"
32.	*A1424	1	Hose Assembly, 1/2" x 30"
33.	*A1189	4	Hose Assembly, 1/4" x 36"
34.	*A3152	2	Hose Assembly, 3/8" x 62"
35.	G6600-08	1	Swivel Tee, 3/4"-16 JIC
36.	G6801-LL-10 GR1466	2 -	X-Long Elbow W/O-Ring, 90°, 7/8"-14 Male JIC To O-Ring O-Ring
37.	*A1073	2	Hose Assembly, 3/8" x 18"
38.	*A1000	2	Hose Assembly, 3/8" x 15"
39.	*A1020	1	Hose Assembly, 3/8" x 48"
40.	*A8272	1	Hose Assembly, 1/2" x 115"
41.	*A3344	1	Hose Assembly, 3/4" x 115"
42.	*A12027	1	Hose Assembly, 3/8" x 116"
43.	*A3292	1	Hose Assembly, 3/8" x 21"
44.	*A1413	1	Hose Assembly, 1/2" x 26"
45.	GD4086	-	ISO Coupler
46.	*A8287 *A8286	- -	Hose Assembly, 1/2" x 456", 12 Row 30" Hose Assembly, 1/2" x 510", 16 Row 30"
47.	G304-C-10	1	Cap Nut, 7/8"-14

* Hydraulic hose is not stocked by KINZE® Repair Parts, but can be made available on a special order basis. Call for quote.

HYDRAULIC HOSES AND FITTINGS ON PLANTER FRAME

(TWL207ggg)

16 Row 30" Shown (Two Wing Lift Cylinders Per Wing)
 12 Row 30" (One Wing Lift Cylinder Per Wing)

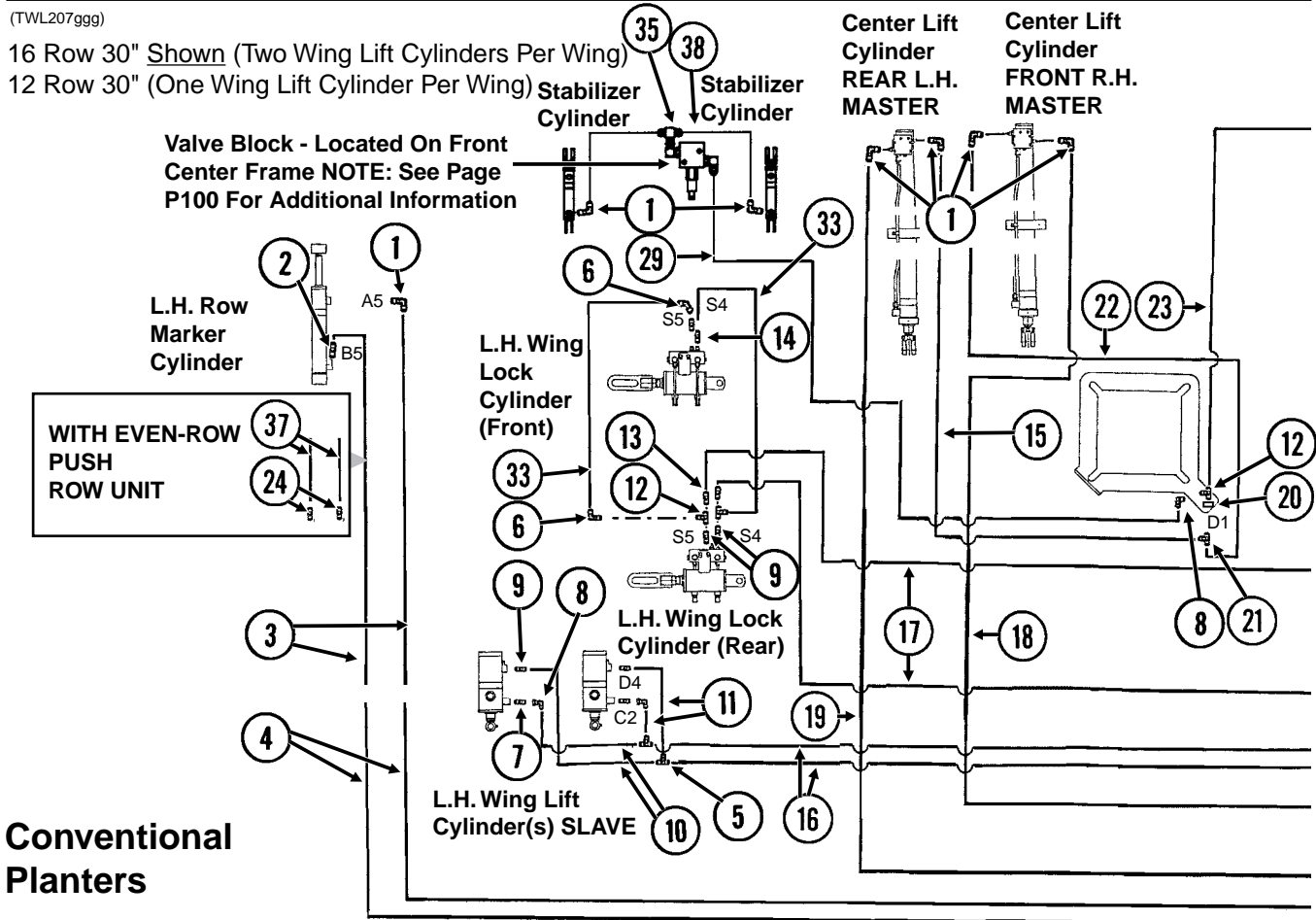

Conventional Planters

ITEM	PART NO.	QTY.	DESCRIPTION
1.	G6801-08 GR1037	8 -	Elbow W/O-Ring, 90°, 3/4"-16 Male JIC To O-Ring O-Ring
2.	G6400-08-04 GR1465	2 -	Connector W/O-Ring, 3/4"-16 Male JIC To 7/16"-20 O-Ring O-Ring
3.	*A3220 *A3219	4 -	Hose Assembly, 3/8" x 82", 12 Row 30" Hose Assembly, 3/8" x 104", 16 Row 30"
4.	*A3101 *A3161	4 -	Hose Assembly, 3/8" x 168", 12 Row 30" Hose Assembly, 3/8" x 210", 16 Row 30"
5.	G2603-08	4	Tee, 3/4"-16 Male JIC
6.	G6502-08	11	Swivel Elbow, 45°, 3/4"-16 Male JIC To Female
7.	G6400-L-08 GR1037	2-4 -	Long Connector W/O-Ring, 3/4"-16 Male JIC To O-Ring O-Ring
8.	G6500-08	3-5	Swivel Elbow, 90°, 3/4"-16 Male JIC To Female
9.	G6400-08 GR1037	6-8 -	Connector W/O-Ring, 3/4"-16 Male JIC To O-Ring O-Ring
10.	*A1018	4	Hose Assembly, 3/8" x 40"
11.	*A3218	4	Hose Assembly, 3/8" x 8"
12.	G6602-08	5	Swivel Tee, 3/4"-16 JIC
13.	G2406-08-06	4	Reducer, 3/4"-16 Female JIC To 9/16"-18 Male JIC
14.	G6400-06-08 GR1037	4 -	Connector W/O-Ring, 9/16"-18 Male JIC To 3/4"-16 O-Ring O-Ring
15.	*A1098	3	Hose Assembly, 3/8" x 26"
16.	*A1054 *A3163	4 -	Hose Assembly, 3/8" x 204", 12 Row 30" Hose Assembly, 3/8" x 225", 16 Row 30"
17.	*A1008	2	Hose Assembly, 3/8" x 110"
18.	*A1021	1	Hose Assembly, 3/8" x 56"
19.	*A3128	1	Hose Assembly, 3/8" x 52"

HYDRAULIC HOSES AND FITTINGS ON PLANTER FRAME

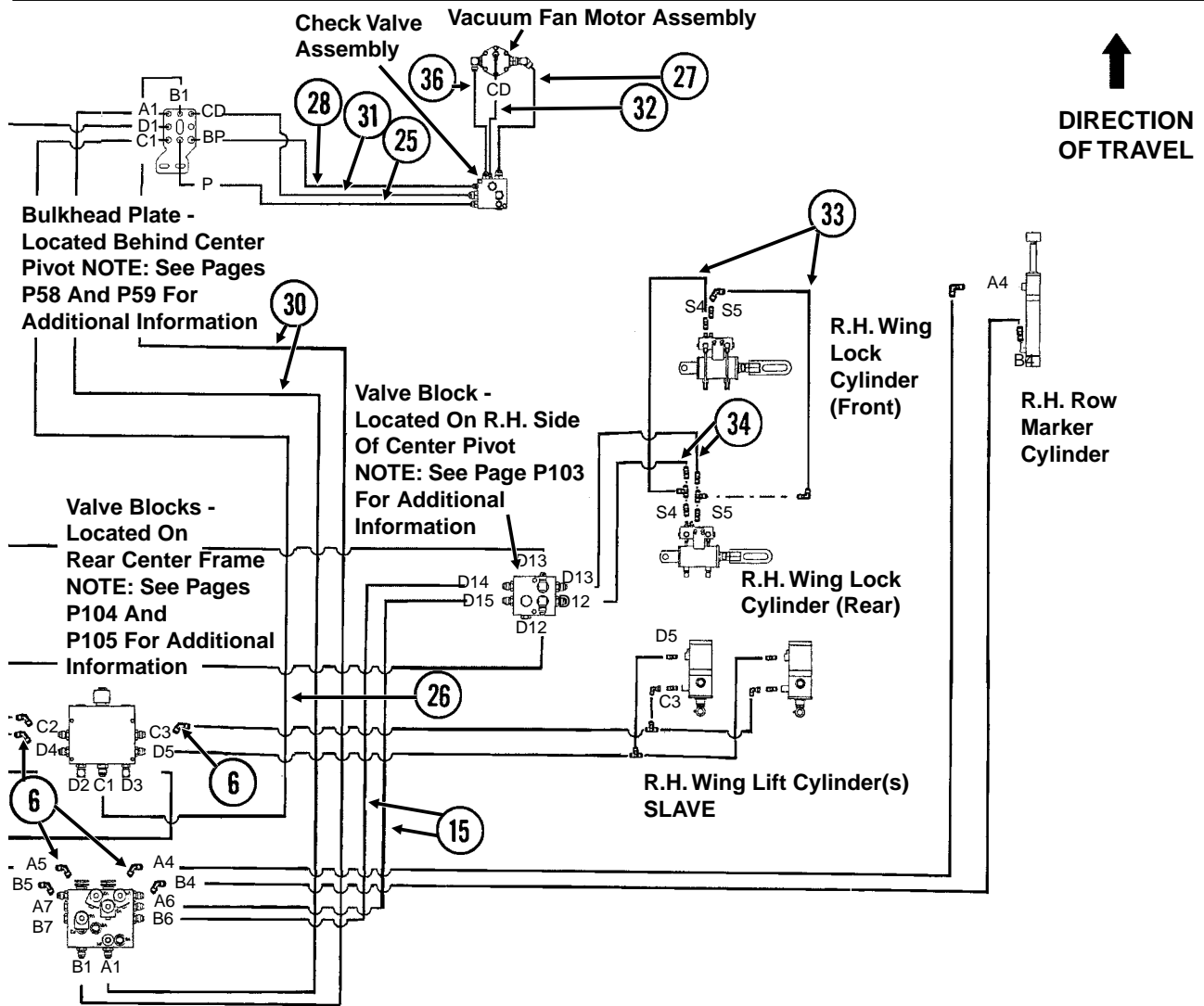

ITEM	PART NO.	QTY.	DESCRIPTION
------	----------	------	-------------

20.	G306-08	1	Lock Nut, 3/4"-16
21.	G2704-08	1	Bulkhead Tee, 3/4"-16 JIC
22.	*A1044	1	Hose Assembly, 3/8" x 34"
23.	*A8222	1	Hose Assembly, 1/2" x 91"
24.	G2403-08	2	Union, 3/4"-16 Male JIC
25.	*A8272	1	Hose Assembly, 1/2" x 115"
26.	*A8221	1	Hose Assembly, 1/2" x 76"
27.	*A3366	1	Hose Assembly, 3/4" x 18"
28.	*A3344	1	Hose Assembly, 3/4" x 115"
29.	*A1020	1	Hose Assembly, 3/8" x 48"
30.	*A1039	2	Hose Assembly, 3/8" x 76"
31.	*A12027	1	Hose Assembly, 3/8" x 116"
32.	*A3292	1	Hose Assembly, 3/8" x 21"
33.	*A1189	4	Hose Assembly, 1/4" x 36"
34.	*A3152	2	Hose Assembly, 3/8" x 62"
35.	G6600-08	1	Swivel Tee, 3/4"-16 JIC
36.	*A1413	1	Hose Assembly, 1/2" x 26"
37.	*A1073	2	Hose Assembly, 3/8" x 18"
38.	*A1000	2	Hose Assembly, 3/8" x 15"

* Hydraulic hose is not stocked by KINZE® Repair Parts, but can be made available on a special order basis. Call for quote.

ELECTRICAL COMPONENTS (Conventional Planters)

(TWL19a/TWL18/ELC14/ELC3a/ELC5c/MTR27a/TWL26e/ELC8/A9481/A10101a/ELC4/TWL23/A9202a/ELC39/A8705/ELC10c)

NOTE: See "Wing Frame",
Pages P68 And P69 For
Light Brackets

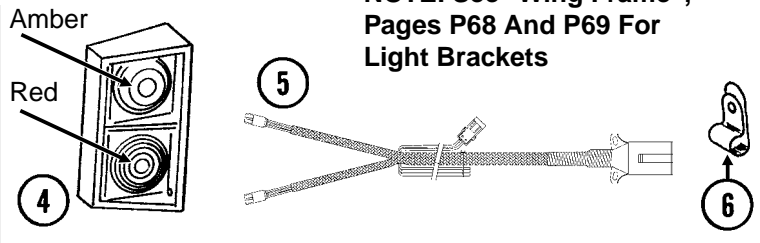
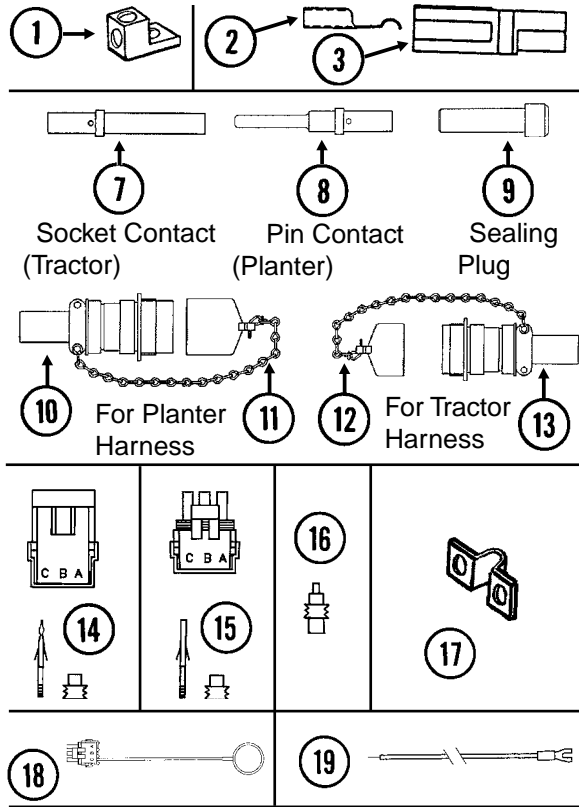

See "Digital Vacuum Gauge, Analog Vacuum Gauge And Vacuum Fan Assembly", Pages P42 And P43 For Vacuum Gauge Electrical Components

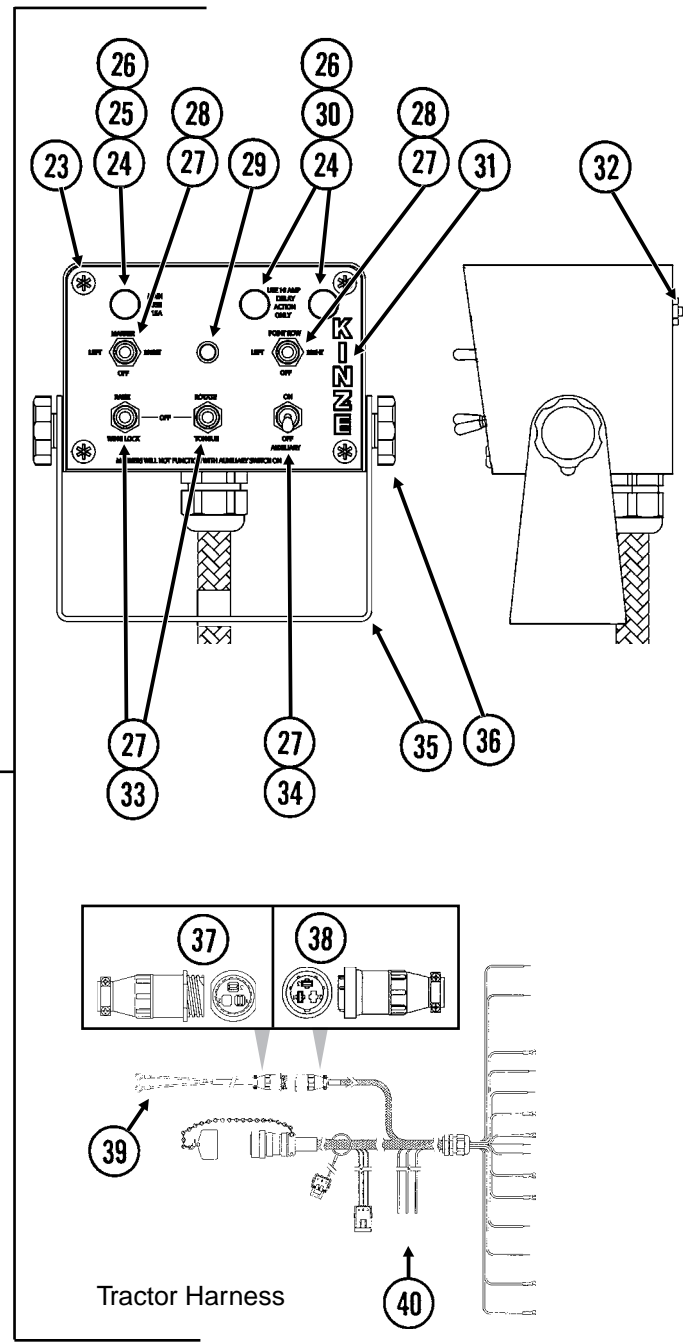
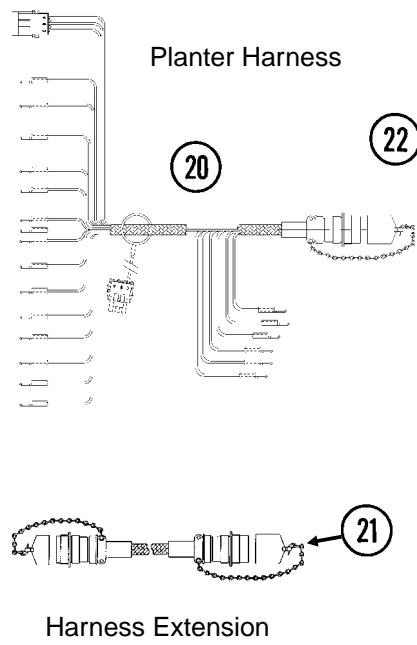

ITEM	PART NO.	QTY.	DESCRIPTION
1.	GA3584	-	Ground Clamp
2.	GD9530	-	Contact
3.	GD9529	-	Housing, Black
	GD12726	-	Housing, Red

ELECTRICAL COMPONENTS (Conventional Planters)

ITEM	PART NO.	QTY.	DESCRIPTION
4.	GA6699	1	Double Light Assembly (Shown)
	GA6700	1	Double Light Assembly
	GR1203	-	Red Lens
	GR1204	-	Amber Lens
	GR1205	-	Cover
	GR1206	-	Rubber Grommet (4)
	GR1207	-	Lamp Unit
	GR1208	-	Bulb
5.	GA9202	-	Wiring Harness W/7 Terminal Female Connector, 786" (2 Light Connections), 12 Row 30"
	GA9204	-	Wiring Harness W/7 Terminal Female Connector, 882" (2 Light Connections), 16 Row 30"
	GA5385	-	7 Terminal Female Connector
6.	GD6291	-	Insulated Clamp, 3/8"
	GD13348	-	Insulated Clamp, 1 1/16"
7.	GD8740	-	Socket Contact, No. 14
8.	GD8741	-	Pin Contact, No. 14
9.	GD8739	-	Sealing Plug, No. 12
10.	GA6109	1	Connector W/Cable Clamp, 23 Pin Capacity
11.	GA7862	-	Dust Cap W/Chain
12.	GA7863	-	Dust Cap W/Chain
13.	GA6108	1	Connector W/Cable Clamp, 23 Socket Capacity
14.	G1K248	-	3-Pin Female Connector Kit (Black), Includes: (3) 3-Pin Female Housings, (9) Pin Contacts, (9) Seals
15.	G1K252	-	3-Pin Male Connector Kit (Black), Includes: (3) 3-Pin Male Housings, (9) Socket Contacts, (9) Seals
16.	GD11089	-	Sealing Plug
17.	GD13310	-	Jumper, 7/16"
18.	GA8047	-	Dust Plug (Black)
19.	GA9481	-	Jumper Wire W/Fork Terminal, 13"
	G10996	-	Fork Terminal
20.	GA10101	1	Wiring Harness W/Dust Cap, 516", 12 Row 30"
	GA10102	-	Wiring Harness W/Dust Cap, 636", 16 Row 30"
21.	GA10547	-	Harness Extension W/Dust Caps, 180"
22.	G7633X	-	Backlit Control Console Assembly W/Mounting Brackets, Short Harness W/Dust Cap And Power Cable
	G7639X	-	Backlit Control Console Assembly W/Mounting Brackets, Short Harness W/Dust Cap And Power Cable (Planters Equipped With Two-Speed Point Row Clutch)
23.	GR1292	4	Pan Head Screw, No. 8-32 x 1/2"
24.	GA2612	3-5	Fuse Holder W/Spade, 1 33/50"
25.	GD2829	1-2	Fuse, 15 Amp, Type AGC
26.	GD3860	3	O-Ring (If Applicable)
27.	GR1363	5-6	Hex Face Nut, 15/32"-32
	GR1364	5-6	Internal Tooth Lock Washer, 15/32"
28.	GA2528	2	Switch, 3 Position Toggle, On-Off-On
29.	GA7077	1-4	Indicator Light
30.	GD10243	4-6	Fuse, MDL 10 Amp Delay Action
31.	GA8734	1	Cover Plate (Shown)
	GA8735	-	Cover Plate (Planters Equipped With Two-Speed Point Row Clutch)
32.	GA8731	1	Switch, Push Button W/Transformer
33.	GA6978	2	Switch, 3 Position Toggle, Momentary On-Off-Momentary On
34.	GA6977	1-2	Switch, 2 Position Toggle, On-Off
35.	GD9896	1	Mounting Bracket
36.	GA6975	2	Knob
	G10211	4	Washer, 1/4" SAE
	GR1290	2	Cage Nut, 1/4"-20
37.	G1K267	-	Power Lead Adapter Connector Kit, Includes: (1) 3-Pin Connector, (1) Cable Clamp, (3) Male Terminal Pins
38.	G1K268	-	Console Cable Connector Kit, Includes: (1) 3-Pin Connector, (1) Cable Clamp, (1) Lock Ring, (3) Female Terminal Pins
39.	GA7856	1	Power Lead Adapter
40.	GA8729	1	Wiring Harness W/Dust Cap And Power Cable

NOTE: See "Point Row Clutch" or "Two-Speed Point Row Clutch" for R.H. and L.H. wiring harness for the point row clutches. See "KPM I/KPM II Stack-Mode Electronic Seed Monitor" for those components.

ELECTRICAL COMPONENTS (SDS Planters)

(TWL19a/TWL18/ELC14/TWL23/A9202a/ELC39/ELC3a/ELC5c/MTR27a/TWL26e/ELC8/A9481/A10556/A10558/A3072/A10101a/ELC4/A10189c/A10189/ELC34/ELC35/ELC10d)

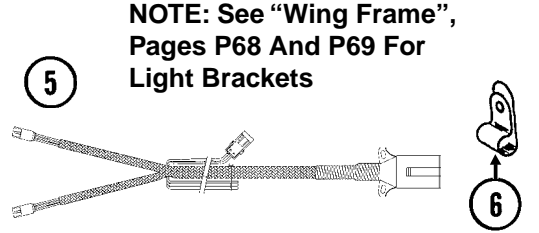
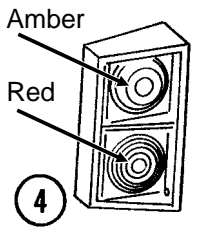
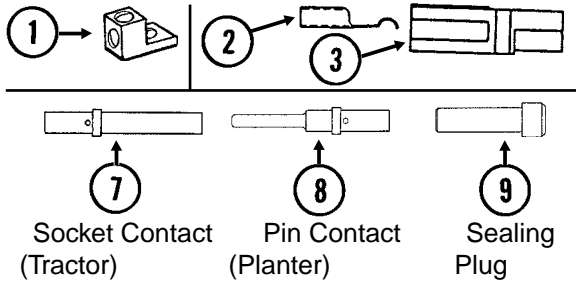

NOTE: See "Wing Frame", Pages P68 And P69 For Light Brackets

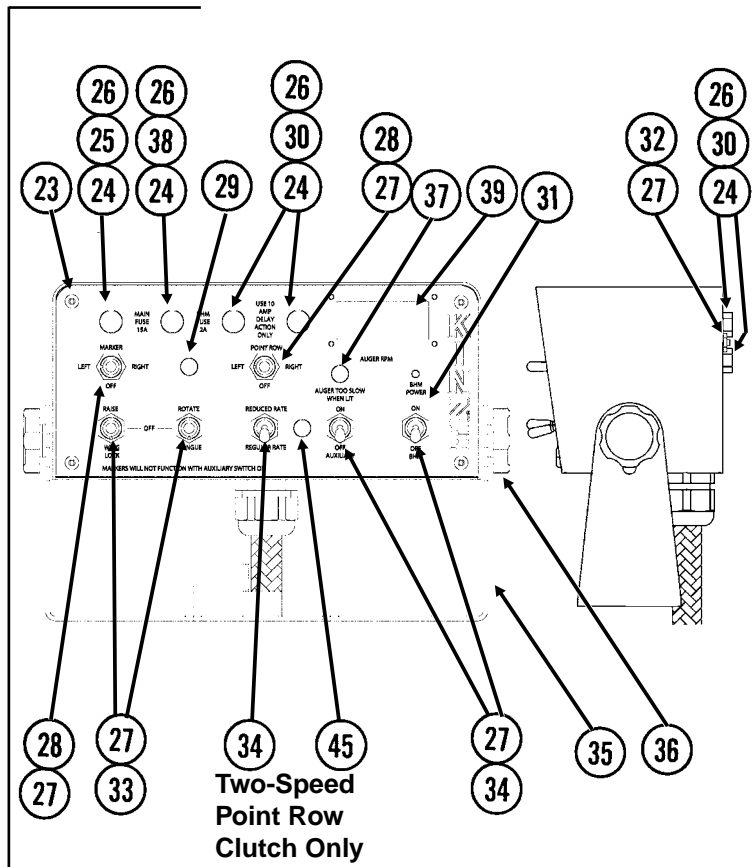
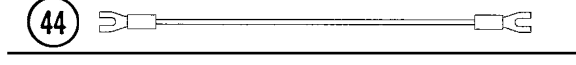
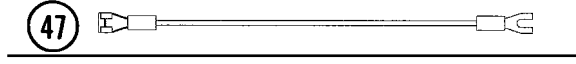
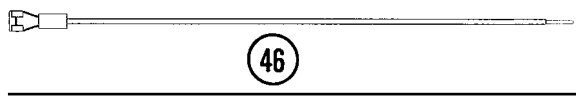
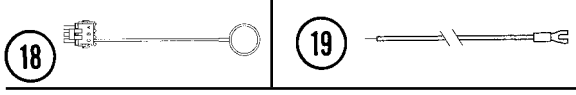
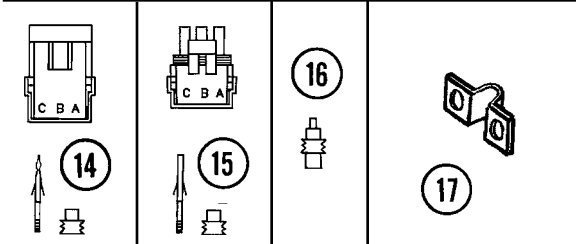
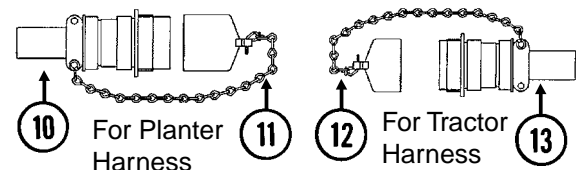

See "Digital Vacuum Gauge, Analog Vacuum Gauge And Vacuum Fan Assembly", Pages P42 And P43 For Vacuum Gauge Electrical Components

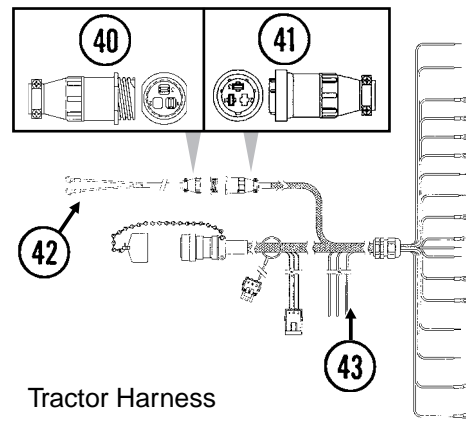
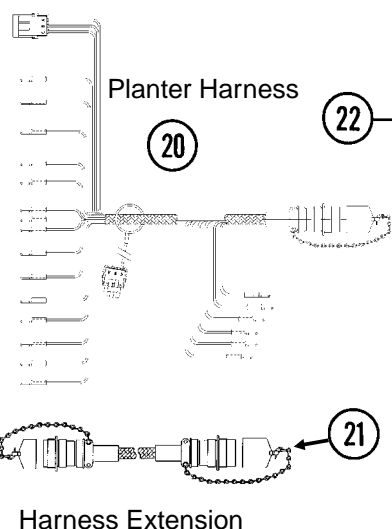

ITEM	PART NO.	QTY.	DESCRIPTION
1.	GA3584	-	Ground Clamp
2.	GD9530	-	Contact
3.	GD9529	-	Housing, Black
	GD12726	-	Housing, Red

ELECTRICAL COMPONENTS (SDS Planters)

ITEM	PART NO.	QTY.	DESCRIPTION
4.	GA6699	1	Double Light Assembly (Shown)
	GA6700	1	Double Light Assembly
	GR1203	-	Red Lens
	GR1204	-	Amber Lens
	GR1205	-	Cover
	GR1206	-	Rubber Grommet (4)
	GR1207	-	Lamp Unit
	GR1208	-	Bulb
5.	GA9202	-	Wiring Harness W/7 Terminal Female Connector, 786" (2 Light Connections), 12 Row 30"
	GA9204	-	Wiring Harness W/7 Terminal Female Connector, 882" (2 Light Connections), 16 Row 30"
	GA5385	-	7 Terminal Female Connector
6.	GD6291	-	Insulated Clamp, 3/8"
	GD13348	-	Insulated Clamp, 1 1/16"
7.	GD8740	-	Socket Contact, No. 14
8.	GD8741	-	Pin Contact, No. 14
9.	GD8739	-	Sealing Plug, No. 12
10.	GA6109	1	Connector W/Cable Clamp, 23 Pin Capacity
11.	GA7862	-	Dust Cap W/Chain
12.	GA7863	-	Dust Cap W/Chain
13.	GA6108	1	Connector W/Cable Clamp, 23 Socket Capacity
14.	G1K248	-	3-Pin Female Connector Kit (Black), Includes: (3) 3-Pin Female Housings, (9) Pin Contacts, (9) Seals
15.	G1K252	-	3-Pin Male Connector Kit (Black), Includes: (3) 3-Pin Male Housings, (9) Socket Contacts, (9) Seals
16.	GD11089	-	Sealing Plug
17.	GD13310	-	Jumper, 7/16"
	GD15462	-	Jumper, 3/8"
18.	GA8047	-	Dust Plug (Black)
19.	GA9481	-	Jumper Wire W/Fork Terminal, 13"
	G10996	-	Fork Terminal
20.	GA10101	1	Wiring Harness W/Dust Cap, 516", 12 Row 30"
	GA10102	-	Wiring Harness W/Dust Cap, 636", 16 Row 30"
21.	GA10547	-	Harness Extension W/Dust Caps, 180"
22.	G7830X	-	Backlit Control Console Assembly W/Mounting Brackets, Short Harness W/Dust Cap And Power Cable (Items 23-43)
23.	GR1292	4	Pan Head Screw, No. 8-32 x 1/2"
24.	GA2612	6	Fuse Holder W/Spade, 1 33/50"
25.	GD2829	1	Fuse, 15 Amp, Type AGC
26.	GD3860	6	O-Ring
27.	GR1363	6	Hex Face Nut, 15/32"-32
	GR1364	6	Internal Tooth Lock Washer, 15/32"
28.	GA2528	2	Switch, 3 Position Toggle, On-Off-On
29.	GA10194	1	Indicator Light, Red
30.	GD10243	4-6	Fuse, MDL 10 Amp Delay Action
31.	GA10191	1	Cover Plate
32.	GA8731	1	Switch, Push Button W/Transformer
33.	GA6978	2	Switch, 3 Position Toggle, Momentary On-Off-Momentary On
34.	GA6977	2-3	Switch, 2 Position Toggle, On-Off
35.	GD14640	1	Mounting Bracket
36.	GA6975	2	Knob
	G10211	4	Washer, 1/4" SAE
	GR1290	2	Cage Nut, 1/4"-20
37.	GA10195	1	Indicator Light, Amber
38.	GD14660	1	Fuse, 2 Amp Delay Action
39.	GA9965	1	Tachometer
40.	G1K267	-	Power Lead Adapter Connector Kit, Includes: (1) 3-Pin Connector, (1) Cable Clamp, (3) Male Terminal Pins
41.	G1K268	-	Console Cable Connector Kit, Includes: (1) 3-Pin Connector, (1) Cable Clamp, (1) Lock Ring, (3) Female Terminal Pins
42.	GA7856	1	Power Lead Adapter
43.	GA10192	1	Wiring Harness W/Dust Cap And Power Cable
44.	GA3072	1	Jumper Wire, 5", Red (Two-Speed Point Row Clutch)
45.	GA10206	1	Indicator Light, Green (Two-Speed Point Row Clutch)
46.	GA10556	1	Jumper Wire, 8", Black (Two-Speed Point Row Clutch)
47.	GA10555	1	Jumper Wire, 5", Red (Two-Speed Point Row Clutch)

NOTE: See "Point Row Clutch" or "Two-Speed Point Row Clutch" for R.H. and L.H. wiring harness for the point row clutches. See "KPM I/KPM II Stack-Mode Electronic Seed Monitor" for those components.

AUXILIARY WORK LIGHTS PACKAGE

(A9689b/MTR27v/A10924)

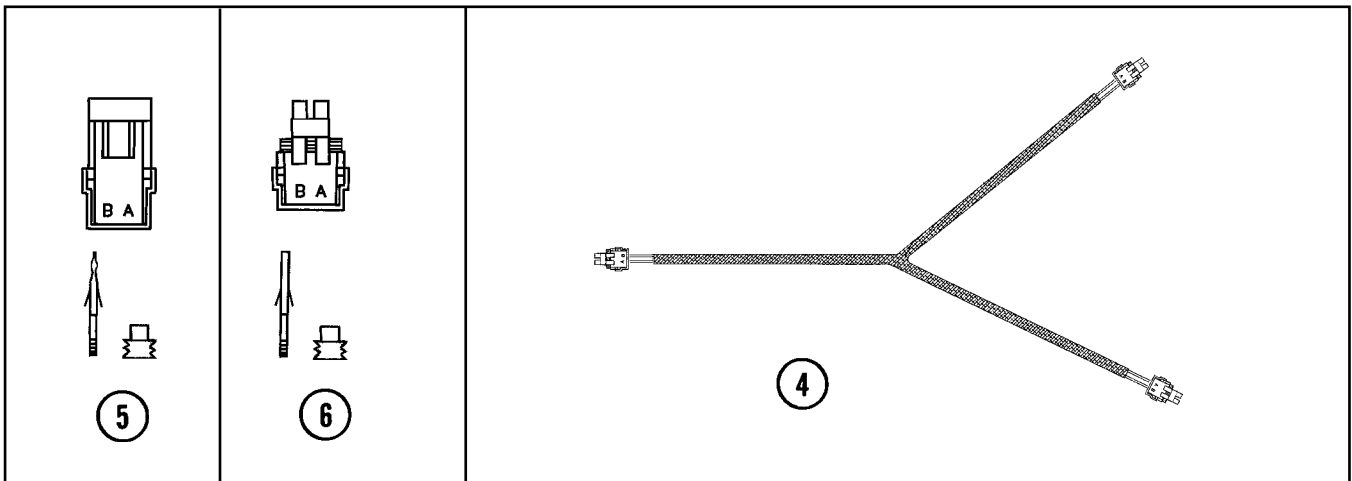
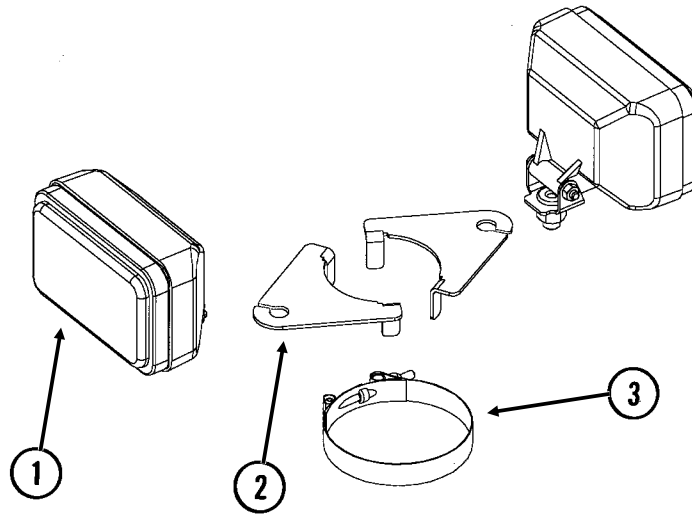

AUXILIARY WORK LIGHTS PACKAGE

ITEM	PART NO.	QTY.	DESCRIPTION
1.	GA9689	2	Work Light Assembly
2.	GD16046	2	Bracket, 4 1/4" x 4", 12 Row 30"
	GD16047	-	Bracket, 4 5/16" x 4 1/8", 16 Row 30"
3.	G11159	2	T-Bolt Clamp, 3 1/2", Stainless Steel, 12 Row 30"
	G11137	-	T-Bolt Clamp, 4 1/4", Stainless Steel, 16 Row 30"
4.	GA10924	1	Wiring Harness, 348"
5.	G1K321	-	2-Pin Female Connector Kit (Black), Includes: (3) 2-Pin Female Housings, (6) Pin Contacts, (6) Seals
6.	G1K320	-	2-Pin Male Connector Kit (Black), Includes: (3) 2-Pin Male Housings, (6) Socket Contacts, (6) Seals

KPM I ELECTRONIC SEED MONITOR

(MTR46b/A11948)

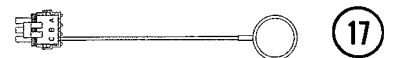
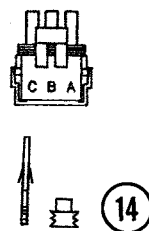
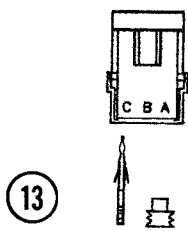
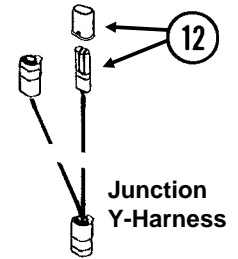
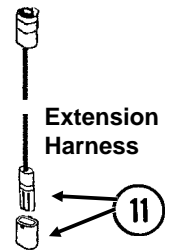
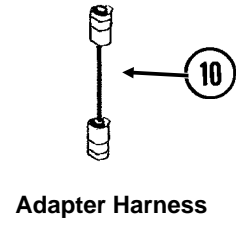
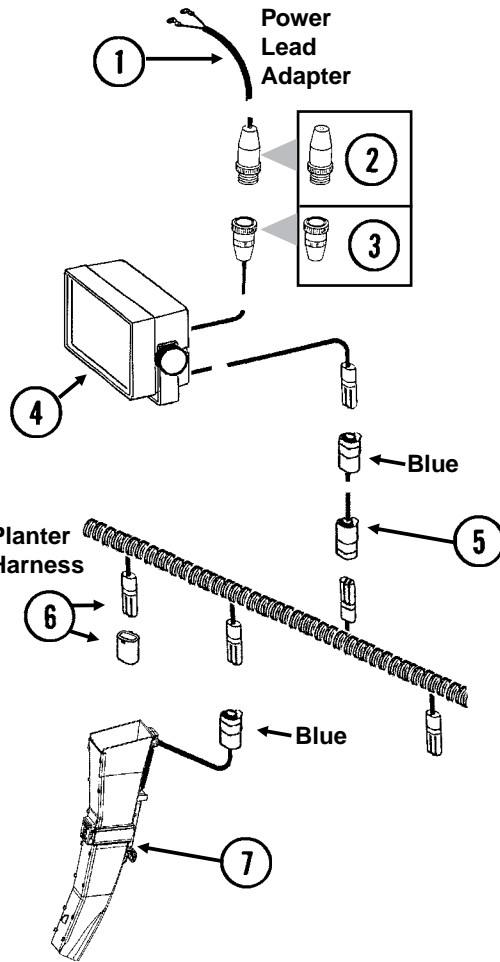
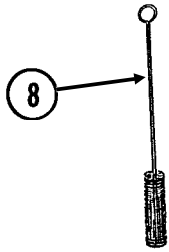
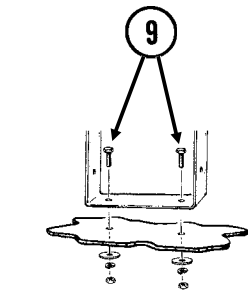

KPM I ELECTRONIC SEED MONITOR

ITEM	PART NO.	QTY.	DESCRIPTION
1.	GA7856	1	Power Lead Adapter
2.	G1K267	-	Power Lead Adapter Connector Kit, Includes: (1) Cable Clamp, (1) 3-Pin Connector, (3) Male Terminal Pins
3.	G1K268	-	Console Cable Connector Kit, Includes: (1) Cable Clamp, (1) 3-Pin Connector, (1) Lock Ring, (3) Female Terminal Pins
4.	GA10570	1	KPM I Backlit Console W/Mounting Bracket, Fuse Holder And Fuse, Power Lead Adapter (Item 1), Brush (Item 10) And Dust Plug (Item 16)
	GR1390	-	Mounting Bracket, KPM I
	GR1392	-	Console Mounting Bracket Hardware Package (Includes 2 Knobs And ¼" Hardware)
	GA10601	-	Fuse Holder
	GD7639	-	Fuse
5.		-	See Tractor/Planter Wiring Harnesses, See Pages P118-P121
6.	GA7851	-	Planter Harness W/Dust Caps, 12 Row (16 Connectors)
	GA7852	-	Planter Harness W/Dust Caps, 16 Row (20 Connectors)
	GD11993	-	Dust Cap
7.	GA11948	-	Seed Tube W/Computerized Sensor, EdgeVac®
	GR1737	-	Sensor Only, EdgeVac®
	GA11947	-	Seed Tube (With Holes For Sensor Installation), EdgeVac®
8.	GR0594	-	Brush
9.	G10022	2	Hex Head Cap Screw, ¼"-20 x ½"
	G10211	2	Washer, ¼" SAE
	G10227	2	Lock Washer, ¼"
	G10103	2	Hex Nut, ¼"-20
10.	GA7857	-	Adapter Harness, 1'
11.	GA7854	-	Extension Harness W/Dust Cap, 15'
	GA7855	-	Extension Harness W/Dust Cap, 30'
	GD11993	-	Dust Cap
12.	GA7853	-	Junction Y-Harness W/Dust Cap
	GD11993	-	Dust Cap
13.	G1K248	-	3-Pin Female Connector Kit (Black), Includes: (3) 3-Pin Female Housings, (9) Pin Contacts, (9) Seals
	G1K362	-	3-Pin Female Connector Kit (Blue), Includes: (3) 3-Pin Female Housings, (9) Pin Contacts, (9) Seals
14.	G1K252	-	3-Pin Male Connector Kit (Black), Includes: (3) 3-Pin Male Housings, (9) Socket Contacts, (9) Seals
	G1K363	-	3-Pin Male Connector Kit (Blue), Includes: (3) 3-Pin Male Housings, (9) Socket Contacts, (9) Seals
15.	GD11089	-	Sealing Plug
16.	GA8046	-	Dust Plug (Black)
	GA9978	-	Dust Plug (Blue)
17.	GA8047	-	Dust Plug (Black)
	GA9979	-	Dust Plug (Blue)

KPM II STACK-MODE/KPM III ELECTRONIC SEED MONITORS

(MTR43jj/A10901a/A11948)

Shaft Rotation Sensor

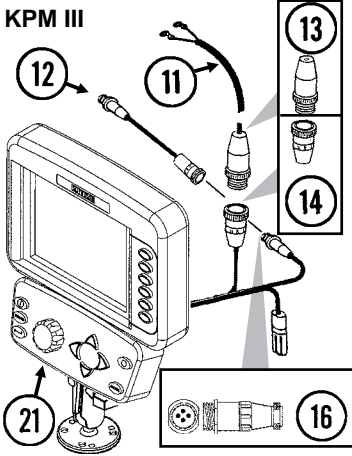
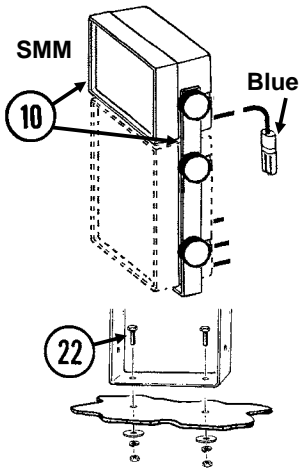
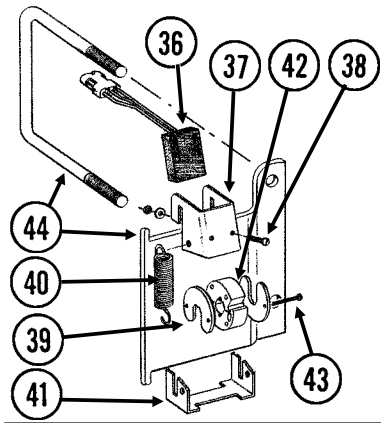

Radar Distance Sensor

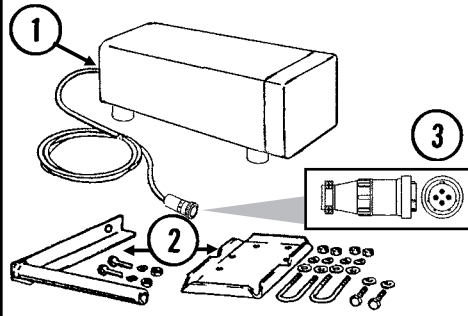

Power Lead Adapter

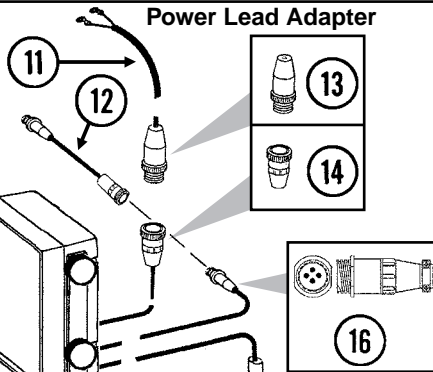

Planter Harness

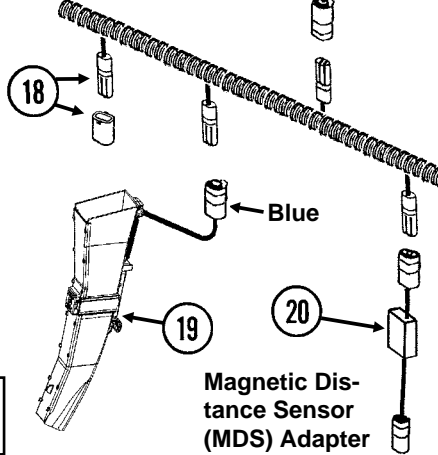

Magnetic Distance Sensor (MDS)

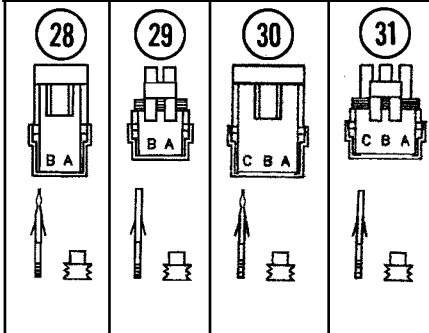
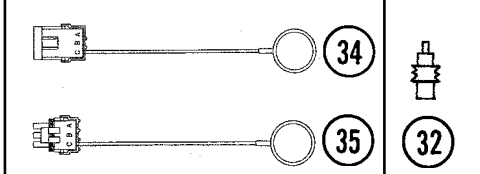
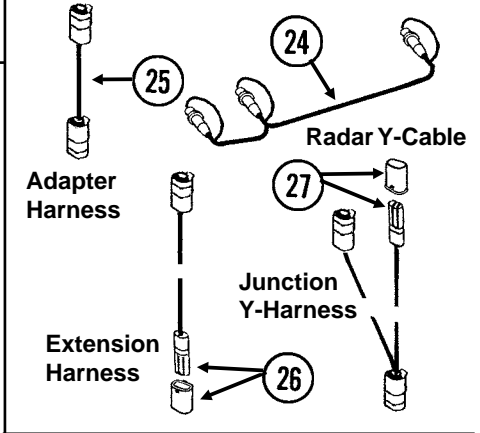
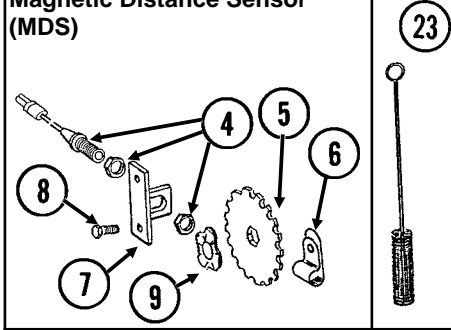

ITEM	PART NO.	QTY.	DESCRIPTION
1.	GA7858	-	Radar Distance Sensor W/20' Cable
2.	GA8026	-	Radar Sensor Pipe/Mounting Bracket Package
3.	G1K323	-	4-Pin Connector Kit W/Female Housing, Includes: (4) Pins And (1) Cable Clamp
4.	GA5600	1	Magnetic Distance Sensor
5.	GD8751	-	Magnetic Distance Sensor Pulse Wheel
6.	GD6291	-	Insulated Clamp, 3/8"
7.	GD8770	1	Bracket
8.	G10001	2	Hex Head Cap Screw, 3/8"-16 x 1"
	G10229	2	Lock Washer, 3/8"
	G10101	2	Hex Nut, 3/8"-16
9.	GD8771	1	Spring Wave Washer
10.	GA9857	1	SMM Backlit Console W/Mounting Bracket And Dust Plug (Item 34)
	GR1631	-	Mounting Bracket, KPM II Stack-Mode And SMM Consoles
	GR1632	-	Console Mounting Bracket Hardware Package (Includes 2 Knobs And 1/4" Hardware)
11.	GA7856	1	Power Lead Adapter

KPM II STACK-MODE/KPM III ELECTRONIC SEED MONITORS

ITEM	PART NO.	QTY.	DESCRIPTION
12.	GA9144	-	Monitor/Radar Adapter Cable, 10"
13.	G1K267	-	Power Lead Adapter Connector Kit, Includes: (1) Cable Clamp, (1) 3-Pin Connector, (3) Male Terminal Pins
14.	G1K268	-	Console Cable Connector Kit, Includes: (1) Cable Clamp, (1) 3-Pin Connector, (1) Lock Ring, (3) Female Terminal Pins
15.	GA10575	-	KPM II Backlit Console W/Mounting Bracket, Fuse Holder And Fuse, Power Lead Adapter (Item 11), Brush (Item 23), Dust Plug (Item 34) And Monitor/Radar Adapter, 10" (Item 12)
	GR1391	-	Mounting Bracket, KPM II
	GR1393	-	Console Mounting Bracket Hardware Package (Includes 4 Knobs And ¼" Hardware)
	GA10601	-	Fuse Holder
	GD7639	-	Fuse
16.	G1K322	-	4-Pin Connector Kit W/Male Housing, (4) Female Socket Contacts And (1) Cable Clamp
17.		-	Included In Tractor/Planter Wiring Harnesses, See Pages P118-P121
18.	GA7851	-	Planter Harness W/Dust Caps, 12 Row (16 Connectors)
	GA7852	-	Planter Harness W/Dust Caps, 16 Row (20 Connectors)
	GD11993	-	Dust Cap
19.	GA11948	-	Seed Tube W/Computerized Sensor, EdgeVac®
	GR1737	-	Sensor Only EdgeVac®
	GA11947	-	Seed Tube (With Holes For Sensor Installation) EdgeVac®
20.	GA7859	1	Magnetic Distance Sensor Adapter (Analog To Digital)
21.	GA11039	1	KPM III Backlit Console W/Brush (Item 23), Dust Plug (Item 34), Mounting Bracket Assembly, Console Mounting Bracket Hardware And Power Harness
	GR1761	-	Mounting Bracket Assembly, Includes: (2) Mounting Brackets, (2) Connector Halves, (1) Compression Spring, (1) Tension Knob, (1) ¼"-20 x 1 ¾" Hex Head Cap Screw, (1) ¼" Plastic Washer, (1) ¼" Steel Washer
	GR1762	-	Console Mounting Bracket Hardware Package, Includes: (3) No. 10-32 x ⅝" Hex Socket Pan Head Screws, (3) No. 20 Lock Washers
	GR1764	-	Power Harness
22.	G10022	2	Hex Head Cap Screw, ¼"-20 x ½"
	G10211	2	Washer, ¼" SAE
	G10227	2	Lock Washer, ¼"
	G10103	2	Hex Nut, ¼"-20
23.	GR0594	-	Brush
24.	GR0586	1	Radar Y-Cable (Used To Connect Radar Distance Sensor For Multiple Functions)
25.	GA7857	-	Adapter Harness, 1'
26.	GA7854	-	Extension Harness W/Dust Cap, 15'
	GA7855	-	Extension Harness W/Dust Cap, 30'
	GD11993	-	Dust Cap
27.	GA7853	-	Junction Y-Harness W/Dust Cap
	GD11993	-	Dust Cap
28.	G1K321	-	2-Pin Female Connector Kit (Black), Includes: (3) 2-Pin Female Housings, (6) Pin Contacts, (6) Seals
29.	G1K320	-	2-Pin Male Connector Kit (Black), Includes: (3) 2-Pin Male Housings, (6) Socket Contacts, (6) Seals
30.	G1K248	-	3-Pin Female Connector Kit (Black), Includes: (3) 3-Pin Female Housings, (9) Pin Contacts, (9) Seals
	G1K362	-	3-Pin Female Connector Kit (Blue), Includes: (3) 3-Pin Female Housings, (9) Pin Contacts, (9) Seals
31.	G1K252	-	3-Pin Male Connector Kit (Black), Includes: (3) 3-Pin Male Housings, (9) Socket Contacts, (9) Seals
	G1K363	-	3-Pin Male Connector Kit (Blue), Includes: (3) 3-Pin Male Housings, (9) Socket Contacts, (9) Seals
32.	GD11089	-	Sealing Plug
33.	G1K249	-	Acre Counter Switch Kit
34.	GA8046	-	Dust Plug (Black)
	GA9978	-	Dust Plug (Blue)
35.	GA8047	-	Dust Plug (Black)
	GA9979	-	Dust Plug (Blue)
36.	GR1415	1	Rotation Sensor
37.	GD11169	1	Mount
38.	G10757	2	Pan Head Screw, No. 10-32 x 1 ¼"
	G10243	2	Washer, No. 10 SAE
	G10758	2	Hex Nut, No. 10-32
39.	GD11474	2	Cover
40.	GD5857	2	Spring
41.	GD11170	1	Spring Mount
42.	GR1414	1	Actuator
43.	G10927	2	Pan Head Machine Screw, No. 8-32 x 1 ¼", Stainless Steel
	G10931	2	Lock Washer, No. 8, Internal/External, Stainless Steel
	G10928	2	Hex Nut, No. 8-32, Stainless Steel
44.	G1K364	-	Rotation Sensor Mount Kit, Includes: (2) Mounts, (2) GD11721 5" x 7" U-Bolts, (4) G10228 Lock Washers, (4) G10102 Hex Nuts, (1) Instruction
45.	GA5549	1	Magnetic Distance Sensor Pulse Wheel
A.	GA6147	-	Magnetic Distance Sensor And Mounting Package (Items 4-9)

BULK FILL SEED HOPPER MONITOR COMPONENTS

(TWL230a/A9952/A7287/A9953b/TWL24f)

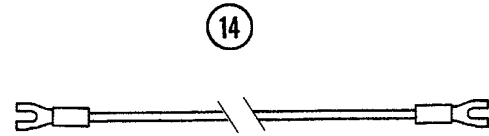
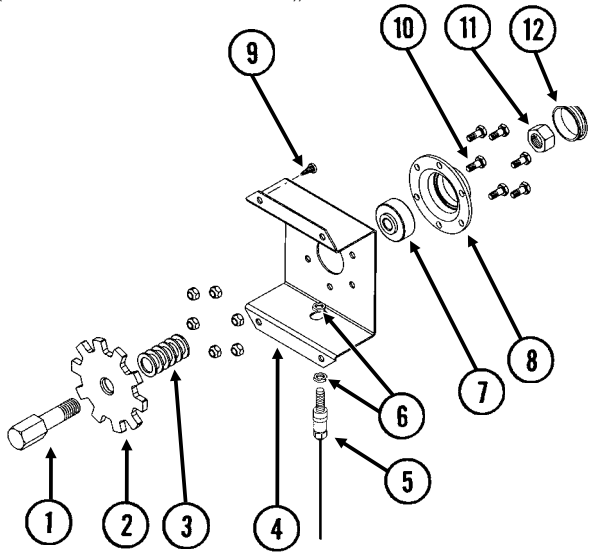

Jumper Wire Between Terminal Strips On Valve Block On Rear Center Frame (See Pages P104 And P105)

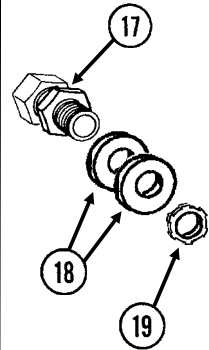
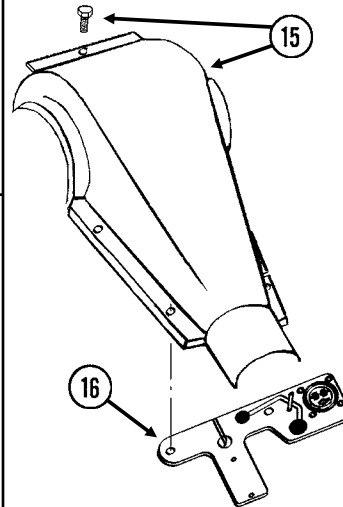
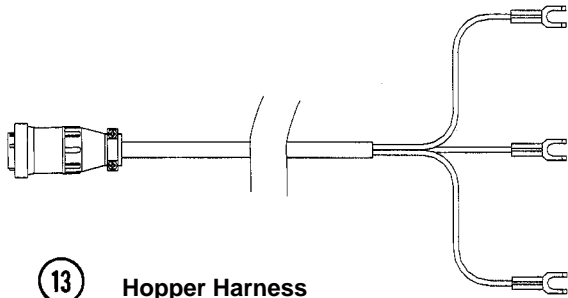

BULK FILL SEED HOPPER MONITOR COMPONENTS

ITEM	PART NO.	QTY.	DESCRIPTION
1.	GD14256	1	Speed Sensor Shaft
2.	GD14255	1	Sensor Wheel
3.	G10918	6	Machine Bushing, 5/8", 14 Gauge
4.	GD14254	1	Bracket
5.	GA9954	1	Speed Sensor Assembly
6.	GD14257	2	Nut, M12 x 1"
7.	GA2014	1	Bearing
8.	GD10473	1	Bearing Housing
9.	G11062	4	Sheet Metal Screw, 1/4"-14 x 1/2"
10.	G10020	6	Hex Head Cap Screw, 1/4"-20 x 5/8"
	G10110	6	Lock Nut, 1/4"-20, Grade B
11.	G10104	1	Hex Nut, 5/8"-11
12.	GD11845	1	Dust Cap
13.	GA9952	2	Hopper Harness, 84"
14.	GA7287	1	Jumper Wire W/Fork Terminals, 13"
15.		-	See "Bulk Seed Hopper Auger Manifold Assembly", Pages P20 And P21
16.	GA9953	2	Seed Flow Sensor Assembly
17.	GD14270	2	Power Cable Connector
18.	G10235	4	Machine Bushing, 7/8", 14 Gauge
19.	GD4163	2	Lock Nut, 1/2" Conduit

INTERPLANT® PUSH ROW UNIT DRIVE

(TWL33r/TWL247aa/TWL246bb)

L.H. Side Shown

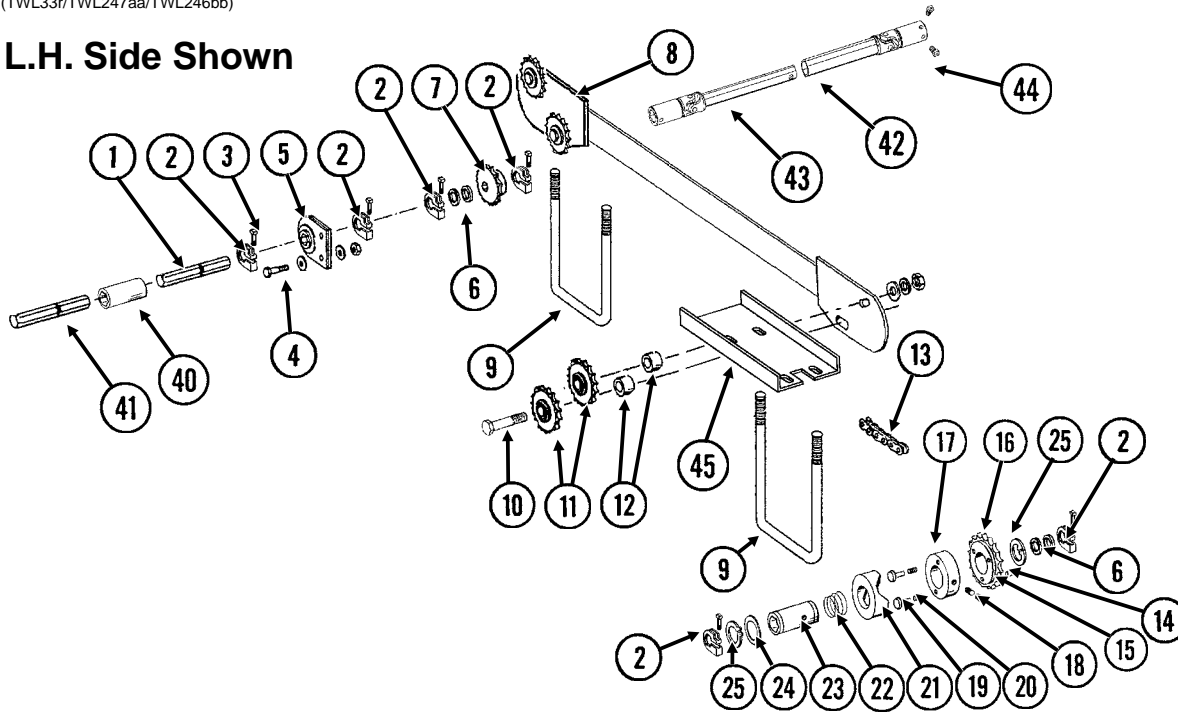

Special Push Row Unit Drive Kit (For Use W/Frame Mounted Coulters On Pull Row Units)

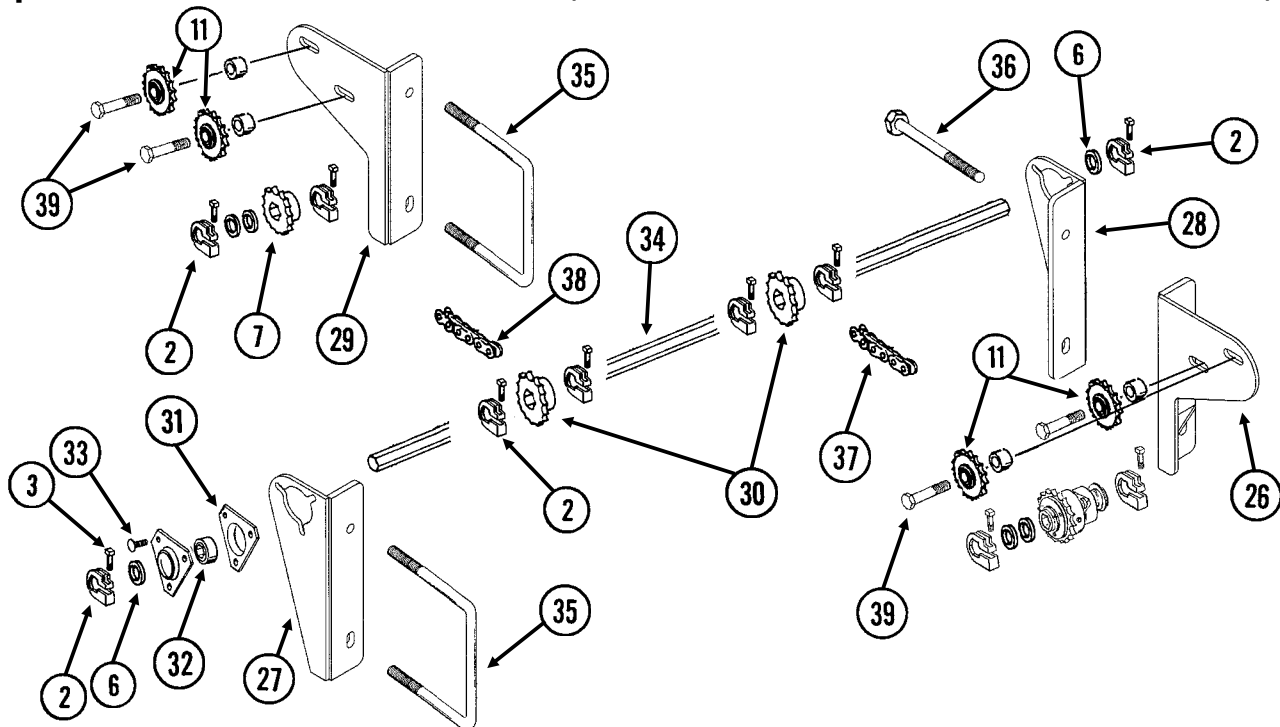

ITEM	PART NO.	QTY.	DESCRIPTION
1.	GD0914-48	1	Hex Shaft, 7/8" x 48" (No Holes), R.H. Center Frame, 12 Row 30" And 16 Row 30"
	GD0914-66	1-2	Hex Shaft, 7/8" x 66" (No Holes), L.H. Center Frame And R.H. Wing, 12 Row 30"/L.H. Center Frame, 16 Row 30"
	GD0914-76	1	Hex Shaft, 7/8" x 76" (No Holes), L.H. Wing, 12 Row 30"
	GD0914-124	1	Hex Shaft, 7/8" x 124" (No Holes), R.H. Wing, 16 Row 30"
	GD0914-138	1	Hex Shaft, 7/8" x 138" (No Holes), L.H. Wing, 16 Row 30"

INTERPLANT® PUSH ROW UNIT DRIVE

ITEM	PART NO.	QTY.	DESCRIPTION
2.	GD11045	-	Lock Clamp
3.	G10130	-	Square Head Machine Bolt, 5/16"-18 x 1 3/4"
	G10923	-	Flange Nut, 5/16"-18, No Serration
4.	G10004	-	Hex Head Cap Screw, 3/8"-16 x 1 1/4"
	G10210	-	Washer, 3/8" USS
	G10229	-	Lock Washer, 3/8"
	G10101	-	Hex Nut, 3/8"-16
5.	GA2180	-	Hanger Bearing, 7/8" Hex Bore
6.	G10233	-	Machine Bushing, 1", 10 Gauge (As Required)
7.	GA5107	1	Sprocket, 19 Tooth
8.	GA9138	1	Mount
9.	GD8306	2	U-Bolt, 7" x 5" x 1/2"-13
	G10228	4	Lock Washer, 1/2"
	G10102	4	Hex Nut, 1/2"-13
10.	G10581	4	Hex Head Cap Screw, 1/2"-13 x 2 1/4"
	G10206	4	Washer, 1/2" SAE
	G10228	4	Lock Washer, 1/2"
	G10102	4	Hex Nut, 1/2"-13
11.	GA7154	4	Sprocket W/Bearing, 18 Tooth
12.	GD9229	4	Spacer, 1 1/4" O.D. x 1/2" Long (If Applicable)
13.	G3310-226	1	Chain, No. 40, 226 Pitch Including Connector Link
	GR0912	-	Connector Link, No. 40
14.	G10968	1	Spring Pin, 5/31" x 7/16"
15.	GR1406	1	Bushing
16.	GR1412	1	Sprocket, 19 Tooth
17.	GR1405	1	Lock Collar
18.	G10535	1	Hex Socket Set Screw, 3/8"-16 x 3/4"
19.	GR1410	1	Pin
20.	GR1413	1	Spring
21.	GR1409	1	Knurled Collar
22.	GR1408	1	Compression Spring
23.	GR1407	1	Drive Shaft
24.	GR1411	1	Shim
25.	G10496	2	External Inverted Snap Ring, 1 1/2"
26.	GA10596	4	Idler Mount, R.H.
27.	GA10597	4	Idler Mount, L.H.
28.	GA10598	4	Bearing Mount, R.H.
29.	GA10599	4	Bearing Mount, L.H.
30.	GA5106	8	Sprocket, 17 Tooth
31.	G3400-01	16	Flangette
32.	G2100-03	8	Bearing, 7/8" Hex Bore, Spherical
33.	G10303	24	Carriage Bolt, 5/16"-18 x 1"
	G10219	24	Washer, 5/16" USS
	G10232	24	Lock Washer, 5/16"
	G10106	24	Hex Nut, 5/16"-18
34.	GD0914-30	4	Hex Shaft, 7/8" x 30" (No Holes)
35.	GD11721	12	U-Bolt, 5" x 7" x 1/2"-13
	G10216	-	Washer, 1/2" USS
	G10228	24	Lock Washer, 1/2"
	G10102	24	Hex Nut, 1/2"-13
36.	G11034	4	Hex Head Cap Screw, 1/2"-13 x 7"
	G10228	4	Lock Washer, 1/2"
	G10102	4	Hex Nut, 1/2"-13
37.	G3310-102	4	Chain, No. 40, 102 Pitch Including Connector Link
	GR0912	-	Connector Link, No. 40
38.	G3310-144	4	Chain, No. 40, 144 Pitch Including Connector Link
	GR0912	-	Connector Link, No. 40
39.	G10016	4	Hex Head Cap Screw, 1/2"-13 x 2"
	G10206	4	Washer, 1/2" SAE
	G10228	4	Lock Washer, 1/2"
	G10102	4	Hex Nut, 1/2"-13
40.	GD1719	1	Coupler, 4"
41.	GD0914-30	1	Hex Shaft, 7/8" x 30" (No Holes), Even-Row Push Row Unit, 12 Row 30" And 16 Row 30"
42.	GA11345	2	U-Joint, Female, 10 1/4"
43.	GA11344	2	U-Joint, Male, 12 1/4"
44.	G10688	8	Square Head Set Screw, 3/8"-16 x 5/8"
45.	GD14417	1	Hose Protector (16 Row Only)
A.	GA8092	-	Clutch Sprocket Assembly, 19 Tooth (Items 14-25)
B.	G1K269	-	Lock Clamp Kit (Items 2 And 3)

DOUBLE DISC FERTILIZER OPENER AND MOUNT

FOC007(PT25/A10119/FRTZ208)

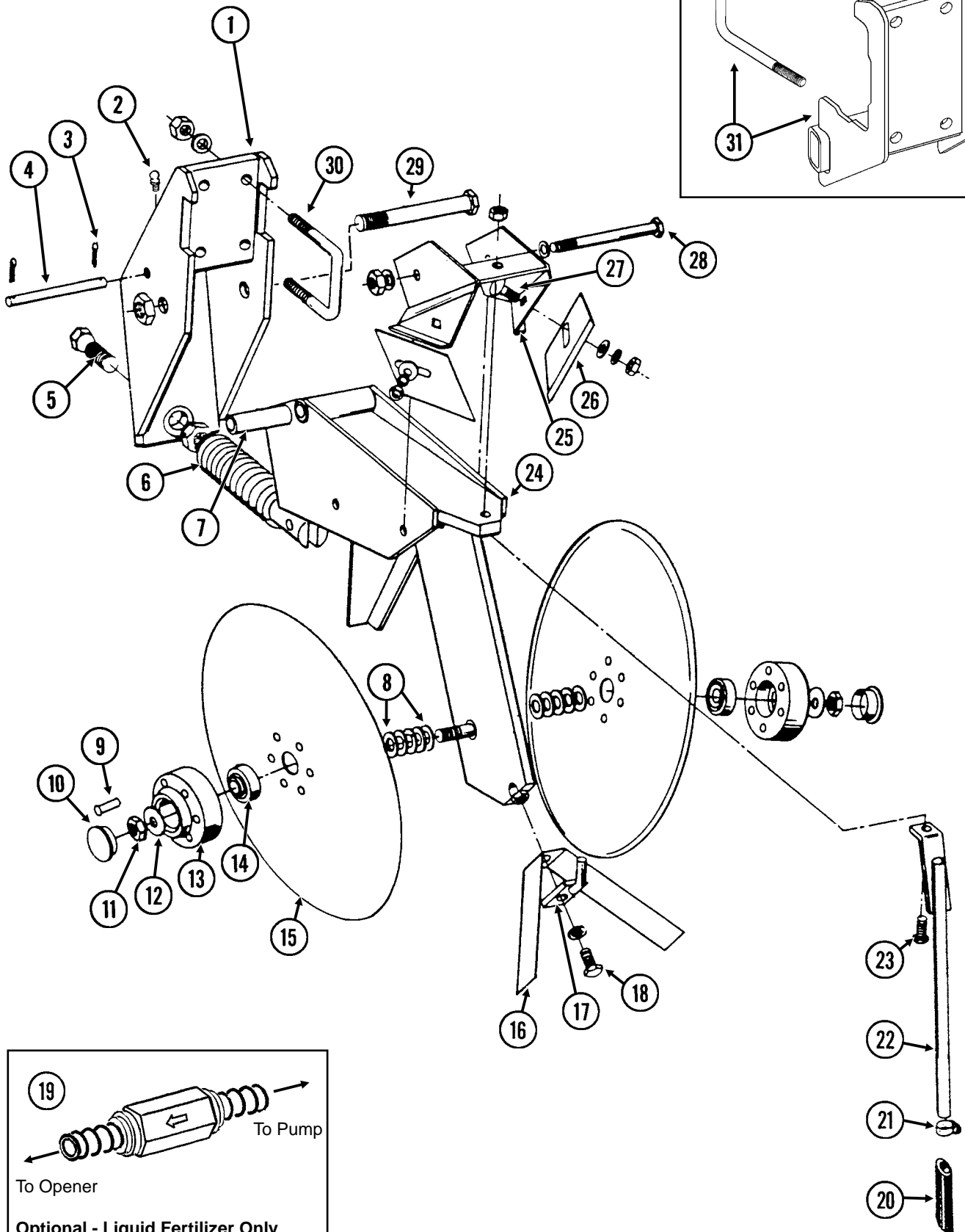

DOUBLE DISC FERTILIZER OPENER AND MOUNT

ITEM	PART NO.	QTY.	DESCRIPTION
		(Per Assy.)	
1.	GA8483	1	Bracket
2.	G10938	1	Grease Fitting, 1/4"-28, Taper Threads
3.	G10451	2	Cotter Pin, 1/8" x 1"
4.	GD1657	1	Lockup Pin
5.	GD0962	1	Hex Head Adjusting Bolt, 5/8"-18 x 3 1/4"
	G10499	1	Hex Jam Nut, 5/8"-18, Grade 2
6.	GA0328	1	Spring
7.	GD0487	1	Bushing, 4 1/64" I.D. x 3 1/2" Long
8.	G10213	-	Machine Bushing, 5/8" (.030" Thick)
9.	G10542	12	Rivet, 1/4" x 1 5/16"
10.	GD1132	2	Dust Cap
11.	G10503	1	Hex Jam Nut, 5/8"-11, Grade 2
	G10504	1	Hex Jam Nut, 5/8"-11, L.H. Threads, Grade 2
12.	G10204	2	Special Machine Bushing, 5/8" x 1" O.D.
13.	GB0134	2	Hub
14.	GA2014	2	Bearing
15.	GD11306	2	Disc Blade, 3.5 mm x 15"
16.	GD2589	1	Inner Scraper
17.	GA0312	1	Mount
18.	G10019	1	Hex Head Cap Screw, 5/16"-18 x 1"
	G10232	1	Lock Washer, 5/16"
19.	GA8983	-	Check Valve, Low Rate
20.	GD11705	-	Extension
21.	G10681	-	Hose Clamp, No. 6
22.	GA8685	-	Drop Tube, Liquid Fertilizer
23.	G10133	1	Hex Head Cap Screw, 5/16"-18 x 1 1/2"
	G10221	1	Washer, 5/16" SAE
	G10109	1	Lock Nut, 5/16"-18, Grade 8
24.	GA9195	1	Shank
25.	GA0810	1	Scraper Mount
26.	GD1673	2	Scraper
27.	G10305	2	Carriage Bolt, 3/8"-16 x 1"
	G10210	2	Washer, 3/8" USS
	G10229	2	Lock Washer, 3/8"
	G10101	2	Hex Nut, 3/8"-16
28.	G10045	1	Hex Head Cap Screw, 1/2"-13 x 4 1/2"
	G10111	1	Lock Nut, 1/2"-13
29.	G10046	1	Hex Head Cap Screw, 5/8"-11 x 5"
	G10107	1	Lock Nut, 5/8"-11
30.	GD13287	2	U-Bolt, 1 1/2" x 2 1/2" x 1/2"-13
	G10228	4	Lock Washer, 1/2"
	G10102	4	Hex Nut, 1/2"-13
31.	GA10119	1	Mount W/U-Bolts
	GD1113	2	U-Bolt, 5" x 7" x 5/8"-11
	G10230	4	Lock Washer, 5/8"
	G10104	4	Hex Nut, 5/8"-11
A.	GA8845	-	Disc Blade And Bearing Assembly (Items 9 And 13-15)

HD SINGLE DISC FERTILIZER OPENER (Soil Press Wheel)

(TWL35d/TWL35b)

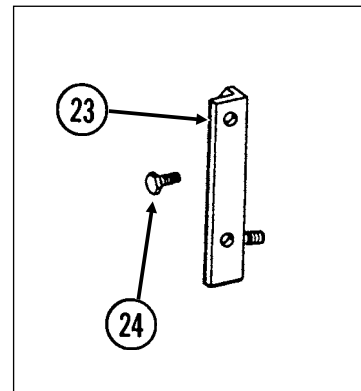
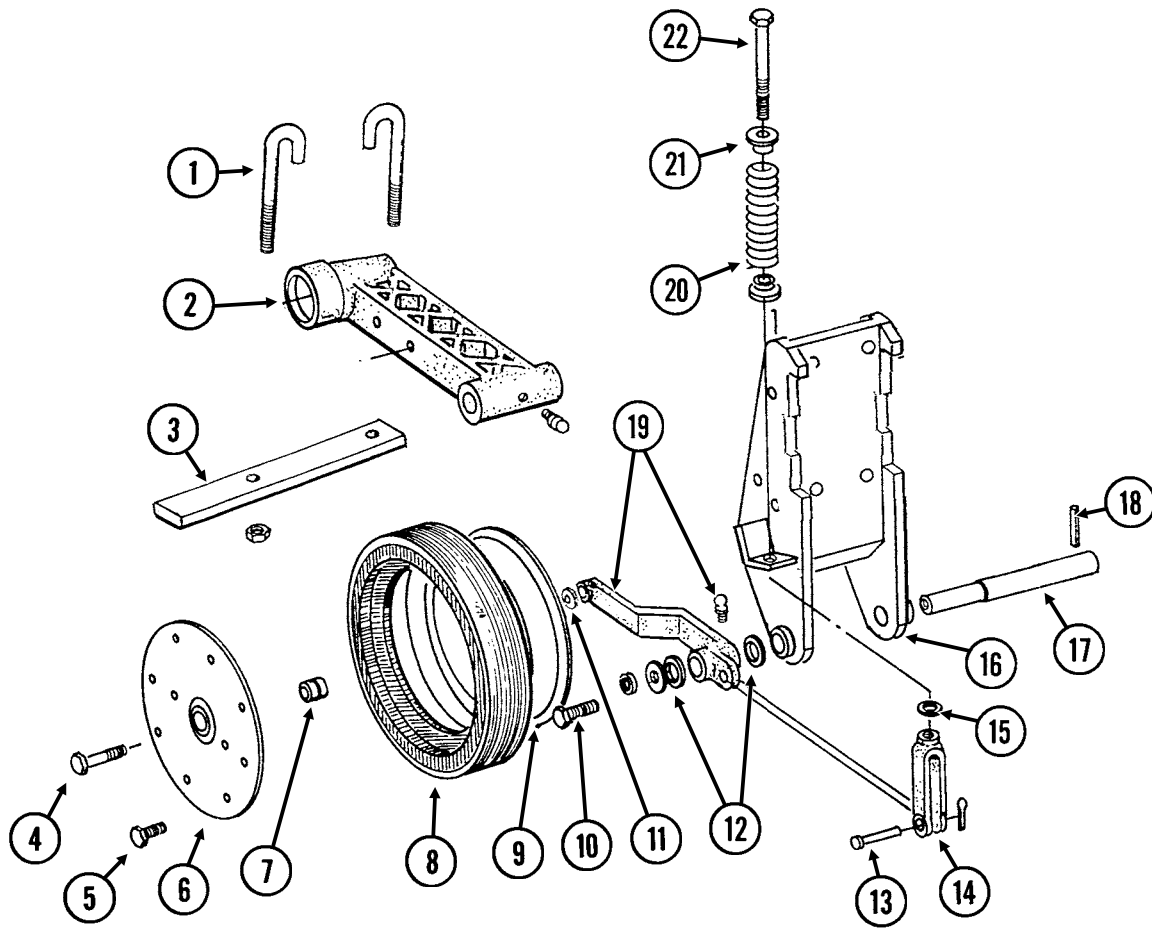

HD SINGLE DISC FERTILIZER OPENER (Soil Press Wheel)

ITEM	PART NO.	QTY. (Per Assy.)	DESCRIPTION
1.	GD9705	2	J-Bolt, 1/2"-13
	G10228	2	Lock Washer, 1/2"
	G10102	2	Hex Nut, 1/2"-13
2.		-	See "HD Single Disc Fertilizer Opener (Blade And Drop Tube)", Pages P136 And P137
3.	GD9706	1	Lockup Bar
4.	G10010	1	Hex Head Cap Screw, 5/8"-11 x 3"
5.	G10961	11	Flanged Whiz Lock Screw, 5/16"-18 x 5/8", No Serration
	G10620	11	Serrated Flange Nut, 5/16"-18
6.	GD11954	1	Half Wheel Cover, Nylon
7.	GA6171	1	Bearing
8.	GD11953	1	Offset Tire
9.	GD11423	1	Half Wheel
10.	G10438	1	Hex Head Cap Screw, 1/2"-13 x 3/4"
	G10228	1	Lock Washer, 1/2"
	G10216	1	Washer, 1/2" USS
11.	G10230	1	Lock Washer, 5/8"
12.	G10526	10	Machine Bushing, 1" (.048" Thick)
13.	G10560	1	Clevis Pin, 1/2" x 1 3/4"
	G10456	1	Cotter Pin, 1/8" x 3/4"
14.	GD8218	1	Yoke
15.	G10205	1	Washer, 5/8" SAE
16.		-	See "HD Single Disc Fertilizer Opener (Blade And Drop Tube)", Pages P136 And P137
17.	GD7911	1	Pivot Pin
18.	G10610	1	Spring Pin, 3/8" x 2"
19.	GA8306	-	Wheel Arm W/Grease Fitting, R.H.
	GA8305	1	Wheel Arm W/Grease Fitting, L.H. (Shown)
	G10640	1	Grease Fitting, 1/4"-28
20.	GD8308	1	Spring
21.	GB0212	2	Washer
22.	GD9709	1	Special Bolt
23.	GA6345	-	Mounting Angle, L.H. (As Required) (Shown)
	GA6344	-	Mounting Angle, R.H. (As Required)
24.	G10005	-	Hex Head Cap Screw, 5/8"-11 x 1 3/4"
	G10230	-	Lock Washer, 5/8"
	G10104	-	Hex Nut, 5/8"-11
A.	G1K215	-	Lockup Kit (Items 1 And 3)
B.	GA8877	-	Gauge Wheel Complete (Items 5-9)

HD SINGLE DISC FERTILIZER OPENER (Blade And Drop Tube)

FOC016/FOC007/FOC019(PT27c/FRTZ208)

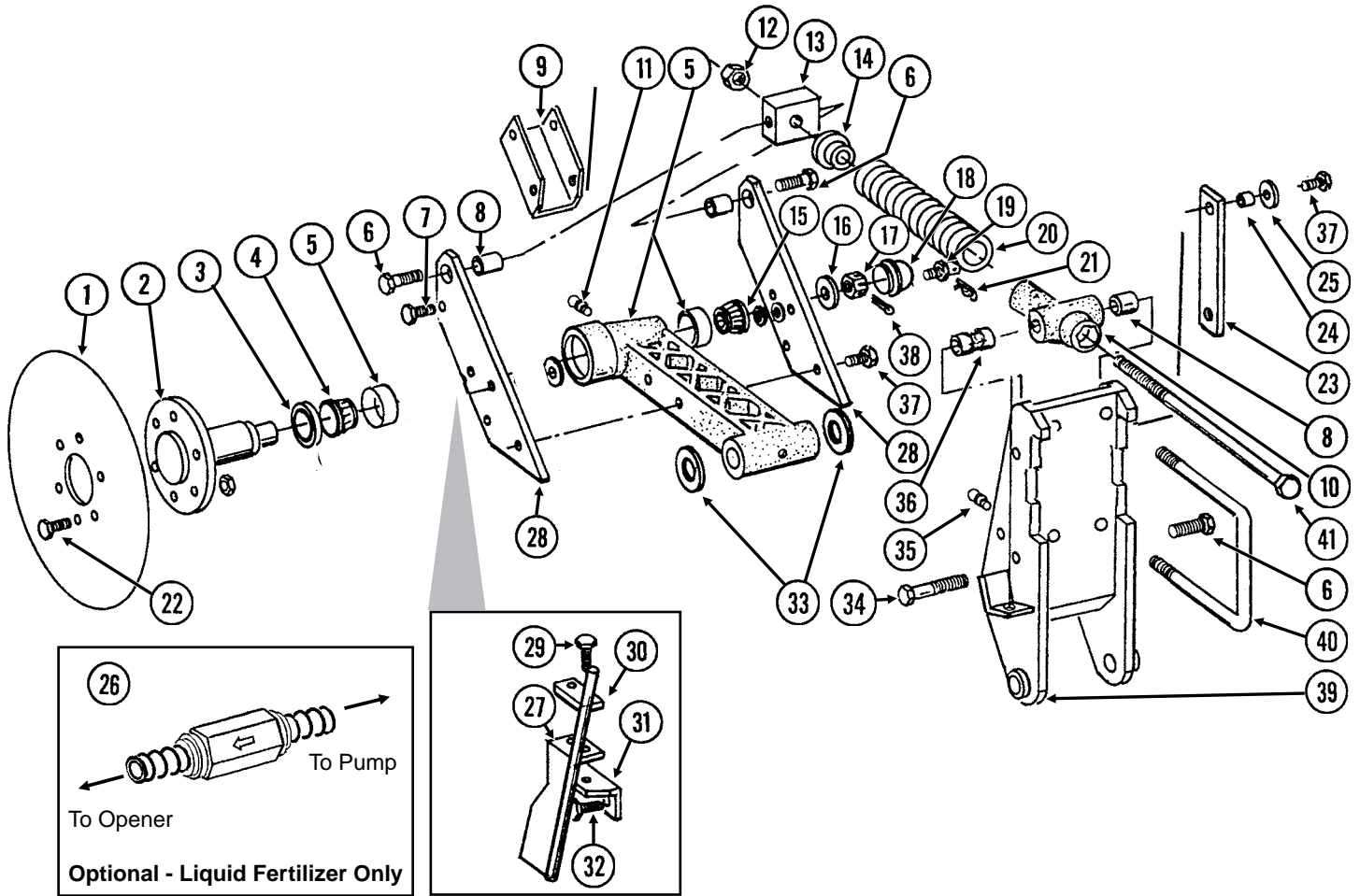

ITEM	PART NO.	QTY.	DESCRIPTION
------	----------	------	-------------

(Per Assy.)

1.	GD7900	1	Disc Blade, 18"
	GD8247	-	Disc Blade, 20" (Optional)
2.	GB0205	1	Spindle
3.	GA4286	1	Seal
4.	GA4287	1	Bearing
5.	GA5887	1	Arm W/Cups And Washers
	GD6553	-	Inner Cup
	GR0188	-	Outer Cup
	G10205	3	Washer, 5/8" SAE
6.	G10007	3	Hex Head Cap Screw, 5/8"-11 x 1 1/2"
7.	G10001	2	Hex Head Cap Screw, 3/8"-16 x 1"
	G10108	2	Lock Nut, 3/8"-16
8.	GB0218	3	Bushing, 2 1/32" I.D. x 7/8" O.D. x 1 19/32" Long
9.	GD8238	1	Channel
10.	GB0206	1	Rod Guide
11.	G10641	2	Grease Fitting, 1/8" NPT
12.	G10105	3	Hex Nut, 3/4"-10
13.	GD7908	1	Tap Block
14.	GB0213	1	Spring Seat
15.	GA0237	1	Bearing
16.	G10220	1	Machine Bushing, 1 1/16", 10 Gauge
17.	G10507	1	Slotted Nut, 1"-14
18.	GD1104	1	Dust Cap

HD SINGLE DISC FERTILIZER OPENER (Blade And Drop Tube)

ITEM	PART NO.	QTY.	DESCRIPTION
		(Per Assy.)	
19.	GD8276	1	Pin
	G10237	1	Lock Washer, 7/16"
	G10100	1	Hex Nut, 7/16"-14
20.	GD10273	1	Compression Spring
21.	G10592	1	Hair Pin Clip, No. 11
22.	G10594	6	Bolt, 1/2"-13 x 1 1/2"
	G10111	6	Lock Nut, 1/2"-13
23.	GD8239	1	Storage Strap
24.	GD7904-02	1	Sleeve, 1/2" x 1/2" Long
25.	G10216	3	Washer, 1/2" USS
26.	GA8983	-	Check Valve, Low Rate
27.	GA8689	1	Drop Tube, L.H., Liquid Fertilizer (Shown)
	GA8688	-	Drop Tube, R.H., Liquid Fertilizer
28.	GD8224	2	Bar
29.	G10004	2	Hex Head Cap Screw, 3/8"-16 x 1 1/4"
	G10229	2	Lock Washer, 3/8"
30.	GD10487	1	Clamp
31.	GD10304	-	Angle, R.H.
	GD10303	1	Angle, L.H. (Shown)
32.	G10016	2	Hex Head Cap Screw, 1/2"-13 x 2"
	G10111	2	Lock Nut, 1/2"-13
33.	G10322	-	Machine Bushing, 1 1/4", 18 Gauge (As Required)
34.	G10862	1	Hex Head Cap Screw, 5/8"-11 x 3 1/4"
	G10205	2	Washer, 5/8" SAE
	G10230	1	Lock Washer, 5/8"
35.	G10640	1	Grease Fitting, 1/4"-28
36.	GD10242	1	Bushing, 2 1/4"
37.	G10039	5	Hex Head Cap Screw, 1/2"-13 x 1 3/4"
	G10111	5	Lock Nut, 1/2"-13
38.	G10459	1	Cotter Pin, 3/16" x 1 1/2"
39.	GA7240	-	Opener Mount, R.H.
	GA7239	1	Opener Mount, L.H. (Shown)
40.	GD1113	2	U-Bolt, 5" x 7" x 5/8"-11
	G10230	4	Lock Washer, 5/8"
	G10104	4	Hex Nut, 5/8"-11
41.	GD7907	1	Special Bolt

NOTCHED SINGLE DISC FERTILIZER OPENER

FOC018(A10119/FRTZ209qQ/FRTZ208/B0405a/A12108)

STYLE A
(Part Number
Stamped On Part)

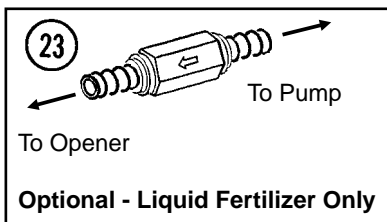
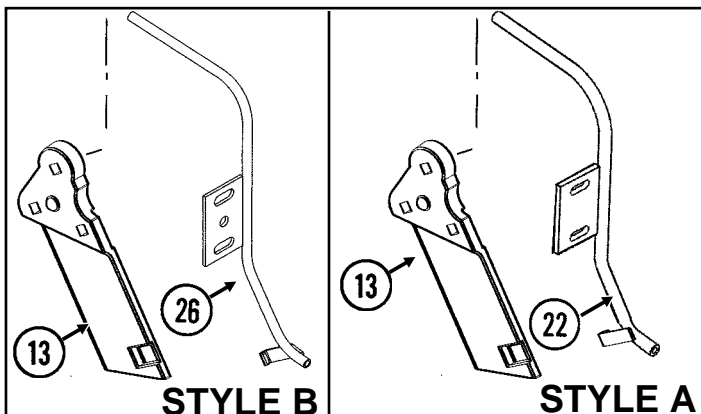
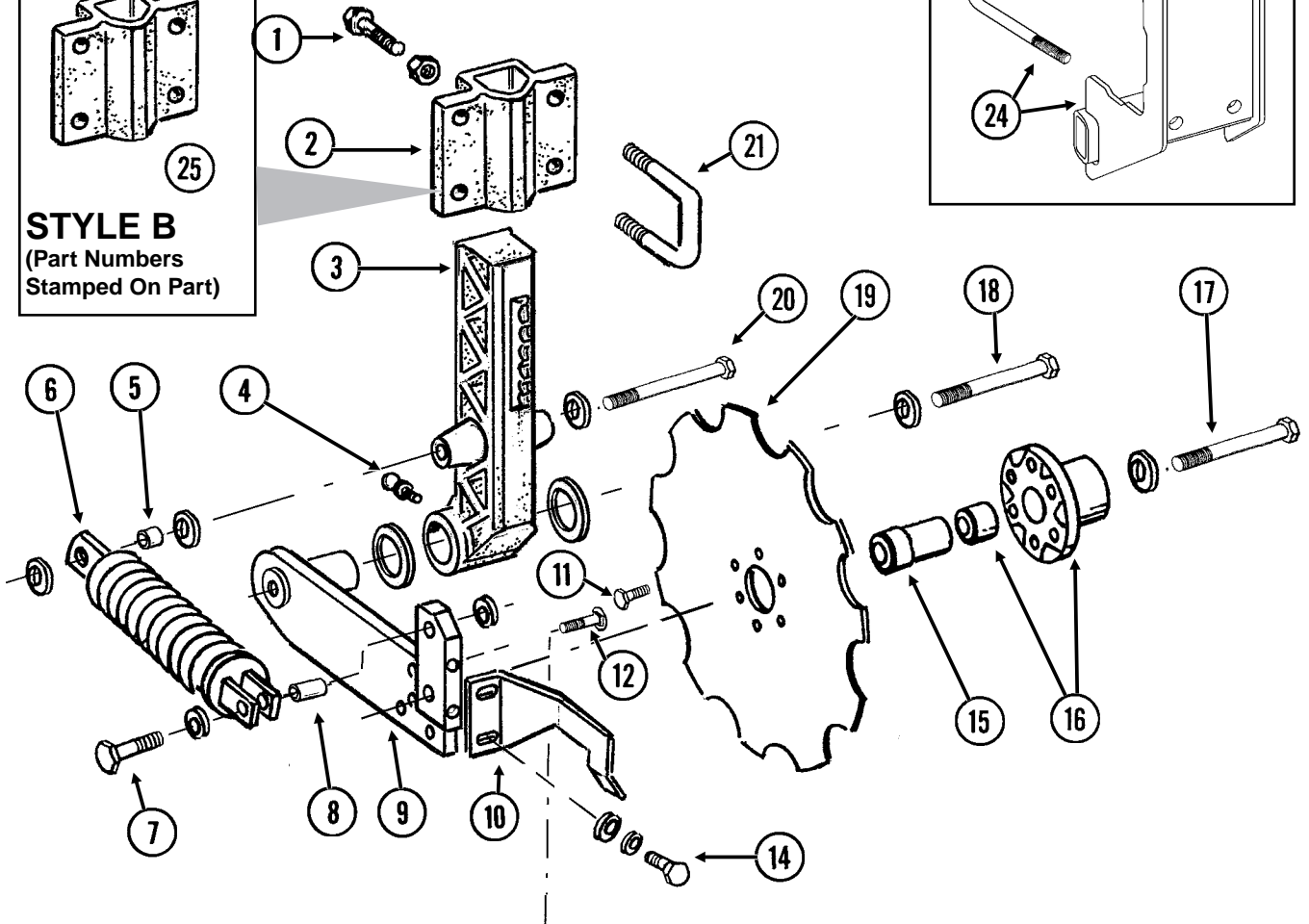
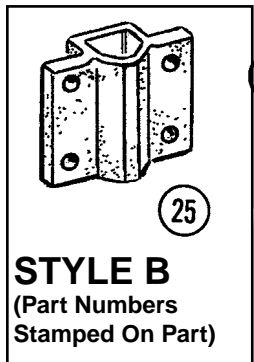
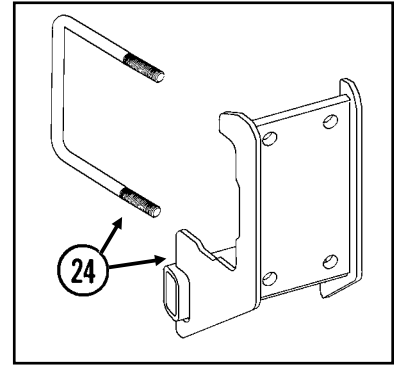

NOTCHED SINGLE DISC FERTILIZER OPENER

ITEM	PART NO.	QTY.	DESCRIPTION
(Per Assy.)			
1.	G10017	3	Hex Head Cap Screw, 1/2"-13 x 1 1/2"
	G10102	3	Hex Nut, 1/2"-13
2.	GB0297	1	Mount
3.	GB0296	1	Arm, 13 1/2"
4.	G10640	1	Grease Fitting, 1/4"-28
5.	GD12685	1	Bushing, 3/4" O.D. x 1/2" Long
6.	GA6966	1	Compression Spring Assembly
7.	G10047	1	Hex Head Cap Screw, 3/8"-16 x 1 3/4"
	G10210	2	Washer, 3/8" USS
	G10108	1	Lock Nut, 3/8"-16
8.	GD1026	1	Sleeve, 1 3/16" Long
9.	GA9433	1	Pivot Arm, L.H. (Shown)
	GA9434	-	Pivot Arm, R.H.
10.	GD11557	1	Scraper, L.H. (Shown)
	GD11558	-	Scraper, R.H.
11.	G10002	6	Hex Head Cap Screw, 3/8"-16 x 3/4"
12.	G10306	3	Carriage Bolt, 3/8"-16 x 2"
	G10108	3	Lock Nut, 3/8"-16
13.	GB0323	1	Knife, L.H. (Shown)
	GB0322	-	Knife, R.H.
14.	G10991	2	Hex Head Cap Screw, 5/16"-18 x 7/8"
	G10232	2	Lock Washer, 5/16"
	G10219	6	Washer, 5/16" USS
15.	GD12679	1	Stepped Spacer, 3" Long
16.	GA9437	1	Hub W/Bearing
	GA8603	-	Bearing, Double Row
17.	G10011	1	Hex Head Cap Screw, 5/8"-11 x 5 1/2"
	GD12677	1	Washer, 1 1/2" O.D., 7 Gauge, Hardened
	G10107	1	Lock Nut, 5/8"-11
18.	G10046	1	Hex Head Cap Screw, 5/8"-11 x 5"
	G10217	1	Washer, 5/8" USS
	G10450	2	Machine Bushing, 1 1/2", 18 Gauge (As Required)
	G10107	1	Lock Nut, 5/8"-11
19.	GD12676	1	Disc Blade, Notched, 16 3/4"
20.	G10871	1	Hex Head Cap Screw, 1/2"-13 x 6"
	G10206	3	Washer, 1/2" SAE
	G10111	1	Lock Nut, 1/2"-13
21.	GD13287	2	U-Bolt, 1 1/2" x 2 1/2" x 1/2"-13
	G10228	4	Lock Washer, 1/2"
	G10102	4	Hex Nut, 1/2"-13
22.	GA11397	-	Drop Tube, L.H., Liquid Fertilizer (Shown)
	GA11398	1	Drop Tube, R.H., Liquid Fertilizer
23.	GA8983	-	Check Valve, Low Rate
24.	GA10119	1	Mount W/U-Bolts
	GD1113	2	U-Bolt, 5" x 7" x 5/8"-11
	G10230	4	Lock Washer, 5/8"
	G10104	4	Hex Nut, 5/8"-11
25.	GB0405	1	Mount, L.H. (Shown)
	GB0400	-	Mount, R.H.
26.	GA12108	1	Drop Tube, Liquid Fertilizer (Shown)
	GA12109	-	Drop Tube, Liquid Fertilizer

DEPTH/GAUGE WHEEL ATTACHMENT FOR NOTCHED SINGLE DISC FERTILIZER OPENER

(FRTZ209u)

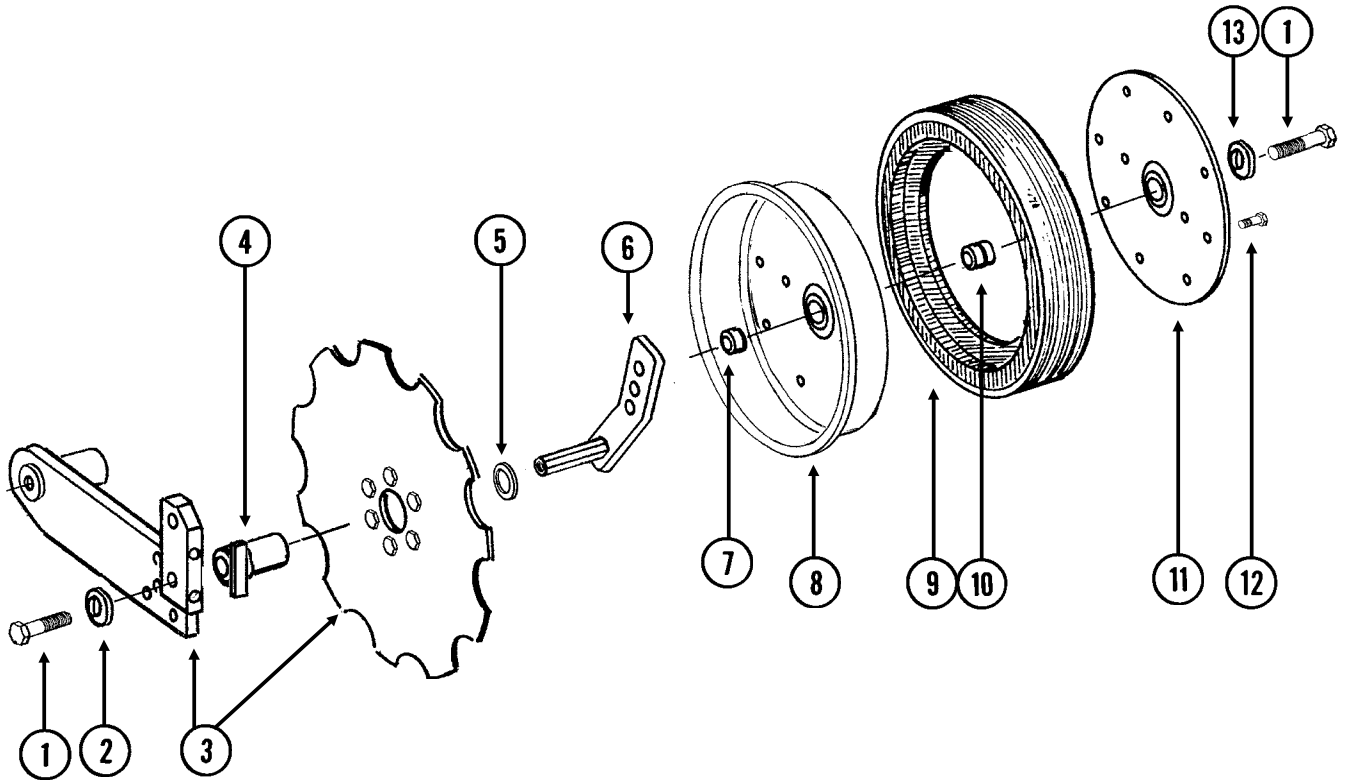

DEPTH/GAUGE WHEEL ATTACHMENT FOR NOTCHED SINGLE DISC FERTILIZER OPENER

ITEM	PART NO.	QTY. (Per Assy.)	DESCRIPTION
1.	G10010	2	Hex Head Cap Screw, 5/8"-11 x 3"
2.	GD7805	1	Special Washer, 5/8", Hardened
3.		-	See "Notched Single Disc Fertilizer Opener", Pages P138 And P139
4.	GA9472	1	Blade Mount
5.	G10233	1	Machine Bushing, 1", 10 Gauge
6.	GA10037	1	Wheel Mount, L.H. (Shown)
	GA10036	1	Wheel Mount, R.H.
7.	GD13309	1	Spacer
8.	GD11423	1	Half Wheel
9.	GD11953	1	Offset Tire
10.	GA6171	1	Bearing
11.	GD11954	1	Half Wheel Cover, Nylon
12.	G10961	11	Flanged Whiz Lock Screw, 5/16"-18 x 3/4", No Serration
	G10620	11	Serrated Flange Nut, 5/16"-18
13.	G10204	1	Special Machine Bushing, 5/8" x 1" O.D. (As Required)
A.	GA8877	-	Gauge Wheel Complete (Items 8-12)

LIQUID FERTILIZER TANKS, SADDLES, SADDLE MOUNTS AND HOSES (SDS Planters)

LFC021/LFC023/LFC030/LFC012(FRTZ201f/FRTZ227)

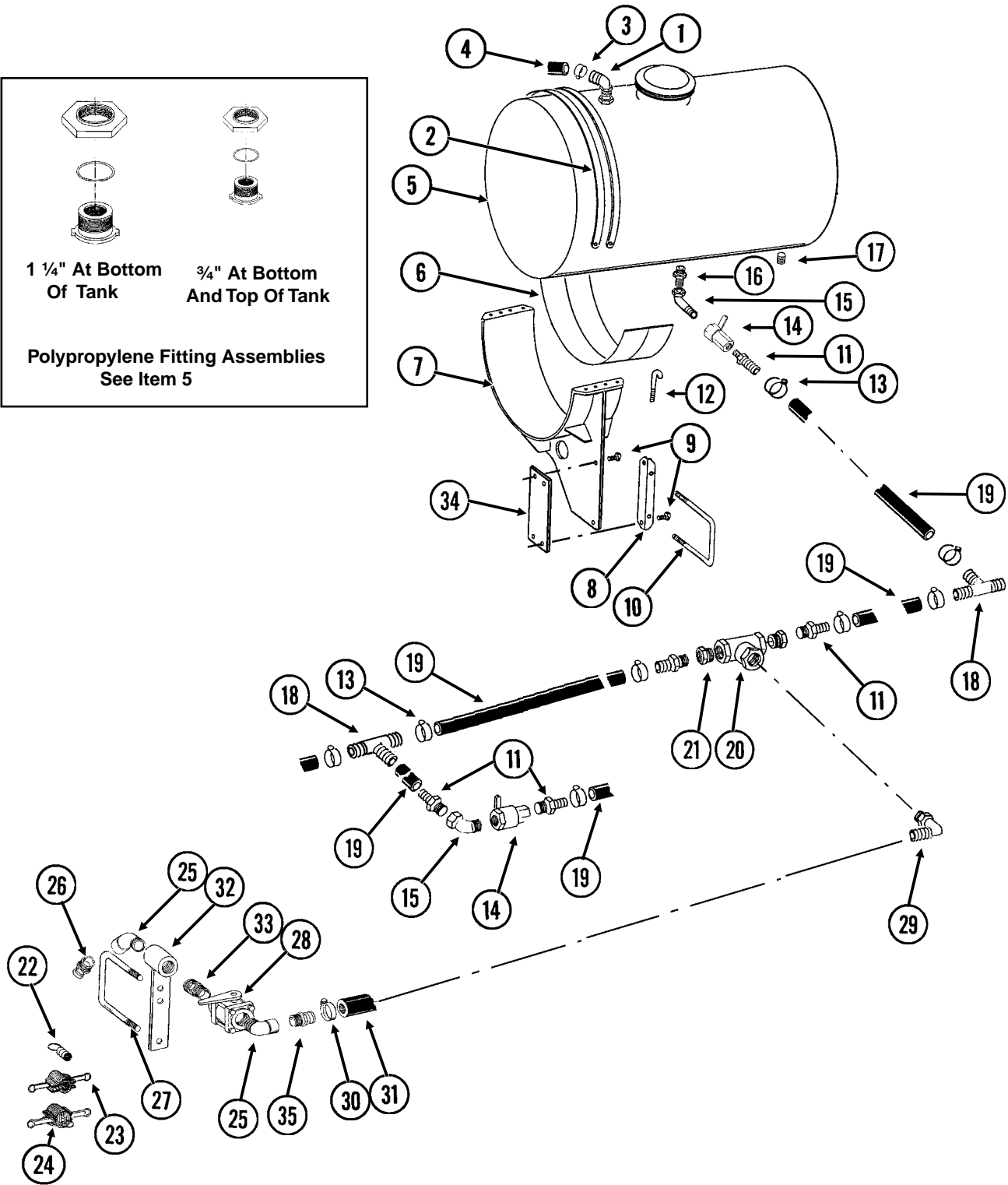
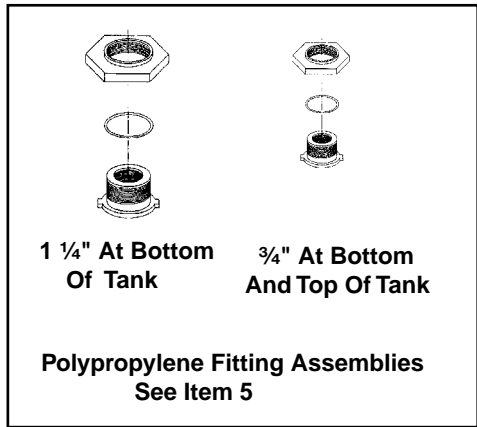

LIQUID FERTILIZER TANKS, SADDLES, SADDLE MOUNTS AND HOSES (SDS Planters)

ITEM	PART NO.	QTY.	DESCRIPTION
1.	G10917	4	Elbow, 90°, ¾" NPT To Barb
2.	GD1520	16	Band, 30" (4 Per Tank)
3.	G10278	4	Hose Clamp, No. 16
4.	G4205-11	-	Hose, ¾" x 72" (One Per Tank)
5.	GA9905	4	Tank W/Lid And Fittings, 30" x 150 Gallon
	GR1678	-	Lid W/Vent, 8" (Top Of Tank)
	GR0513	-	¾" Polypropylene Fitting Assembly (Overflow Fitting, Nut, Bushing And O-Ring) (Top And Bottom Of Tank)
	GR1397	-	Overflow Fitting
	GR0508	-	1 ¼" Polypropylene Fitting Assembly (Nut, Bushing And O-Ring) (Bottom Of Tank)
6.	GD1862	2	Pad, 8" x 14" (For Two 30" Tanks)
7.	GA9671	8	Tank Mount (2 Per Tank)
8.	GD10110	8	Mounting Angle (2 Per Tank)
9.	G10007	24	Hex Head Cap Screw, ⅝"-11 x 1 ½"
	G10230	24	Lock Washer, ⅝"
	G10104	24	Hex Nut, ⅝"-11
10.	GD1747	8	U-Bolt, 5" x 7" x ¾"-10
	G10231	16	Lock Washer, ¾"
	G10105	16	Hex Nut, ¾"-10
11.	G10626	10	Adapter, 1 ¼" NPT To Barb
12.	GD1337	32	J-Bolt, ⅝"-18 (8 Per Tank)
	G11182	32	Lock Nut W/Nylon Insert, ⅝"-18, Grade 8 (8 Per Tank)
13.	G10674	24	Hose Clamp, No. 24
14.	GA4976	5	Shutoff Valve, 1 ¼" NPT
	GR1015	-	Body O-Ring
	GR1016	-	Stem O-Ring
	GR1017	-	Teflon Seat
	GR1018	-	Ball
	GR1019	-	Handle
15.	G10887	5	Elbow, 90°, 1 ¼" Male NPT To Female
16.	G10619	4	Close Nipple, 1 ¼" NPT
17.	G10096	4	Pipe Plug, ¾" NPT
18.	G10633	3	Tee, 1 ¼" Barb
19.	G4200-03	1	Hose, 1 ¼" x 32', 12 Row 30"
	G4200-06	-	Hose, 1 ¼" x 40', 16 Row 30"
20.	G10888	1	Tee, 2" Female NPT
21.	G10616	2	Reducing Bushing, 2" Male NPT To 1 ¼" Female
22.	GD10777	1	Dust Plug, 2" Male Cam Lock
23.	GD3622	1	Adapter, 2" Female NPT To Cam Lock
24.	GD3951	1	Dust Cap, 2" Cam Lock
25.	G10889	2	Elbow, 45°, 2" Male NPT To Female
26.	GD3623	1	Adapter, 2" Male NPT To Cam Lock
27.	GD1113	1	U-Bolt, 5" x 7" x ⅝"-11
	G10230	2	Lock Washer, ⅝"
	G10104	2	Hex Nut, ⅝"-11
28.	GA2660	1	Shutoff Valve, 2" NPT
29.	G10630	1	Elbow, 90°, 2" NPT To Barb
30.	G10676	2	Hose Clamp, No. 36
31.	G4201-03	1	Hose, 2" x 18'
32.	GA7845	1	Quick Fill Mount, 2"
33.	G10623	1	Close Nipple, 2" NPT
34.	GD13648	4	Plate, 4" x 10 ½" (Outboard Tanks Only)
35.	G10628	1	Adapter, 2" NPT To Barb

LIQUID FERTILIZER TANKS, SADDLES, SADDLE MOUNTS AND HOSES (Conventional Planters)

(FRTZ229d/FRTZ228/FRTZ227)

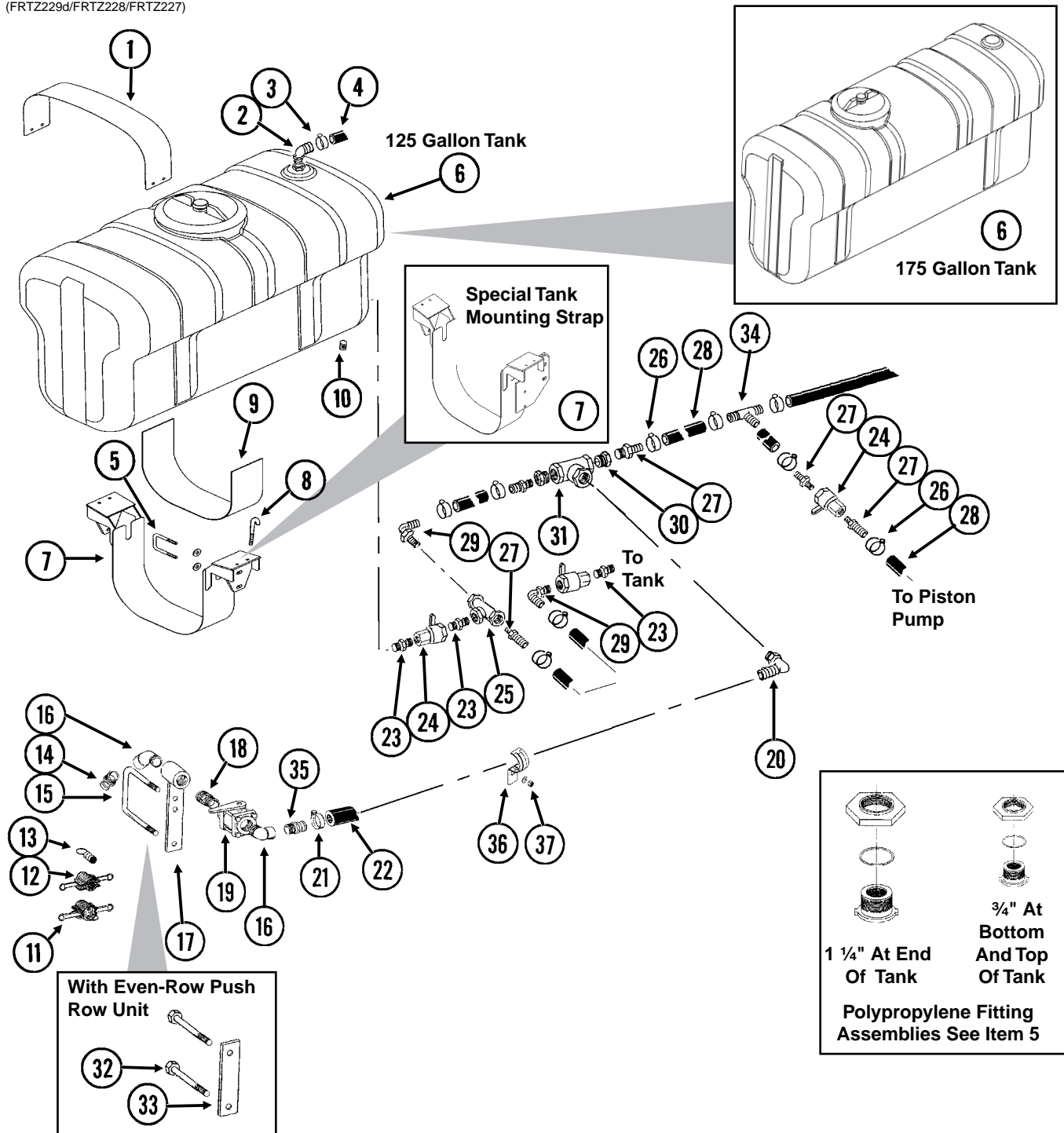

ITEM	PART NO.	QTY.	DESCRIPTION
1.	GA10109	8	Tank Band, 42 3/4" (2 Per Tank)
2.	G10917	4	Elbow, 90°, 3/4" NPT To Barb
3.	G10278	4	Hose Clamp, No. 16
4.	G4205-11	-	Hose, 3/4" x 72" (One Per Tank)
5.	GD1138	16	U-Bolt, 2 1/2" x 2 1/2" x 1/2"-13
	G10216	32	Washer, 1/2" USS
	G10228	32	Lock Washer, 1/2"
	G10102	32	Hex Nut, 1/2"-13

LIQUID FERTILIZER TANKS, SADDLES, SADDLE MOUNTS AND HOSES (Conventional Planters)

ITEM	PART NO.	QTY.	DESCRIPTION
6.	GA10034	-	Tank W/Lid And Fittings, 24" x 125 Gallon (12 Row 30" - Qty. 4) (16 Row 30" - Qty. 2)
	GA10035	-	Tank W/Lid And Fittings, 24" x 175 Gallon (16 Row 30" - Qty. 2)
	GR1702	-	Lid/Fillwell, 8" (Top Of Tank)
	GR1708	-	3/4" Bulkhead Fitting Assembly (Overflow Fitting, Nut, Bushing And O-Ring) (Top And Bottom Of Tank)
	GR1709	-	1 1/4" Bulkhead Fitting Assembly (Nut, Bushing And O-Ring) (End Of Tank)
	GR1686	-	Lanyard, 12 1/2" (Top Of Tank)
7.	GA10833	4	Long Tank Mounting Strap
	GA10834	3	Short Tank Mounting Strap
	GA10835	1	Special Tank Mounting Strap
8.	GD1337	32	J-Bolt, 5/16"-18 (8 Per Tank)
	G11182	32	Lock Nut W/Nylon Insert, 5/16"-18, Grade 8 (8 Per Tank)
9.	GD14517	2	Tank Pad, 6" x 16"
10.	G10096	4	Pipe Plug, 3/4" NPT
11.	GD3951	1	Dust Cap, 2" Cam Lock
12.	GD3622	1	Adapter, 2" Female NPT To Cam Lock
13.	GD10777	1	Dust Plug, 2" Male Cam Lock
14.	GD3623	1	Adapter, 2" Male NPT To Cam Lock
15.	GD1113	1	U-Bolt, 5" x 7" x 5/8"-11
	G10230	2	Lock Washer, 5/8"
	G10104	2	Hex Nut, 5/8"-11
16.	G10889	2	Elbow, 45°, 2" Male NPT To Female
17.	GA7845	1	Quick Fill Mount, 2"
18.	G10623	1	Close Nipple, 2" NPT
19.	GA2660	1	Shutoff Valve, 2" NPT
20.	G10630	1	Elbow, 90°, 2" NPT To Barb
21.	G10676	2	Hose Clamp, No. 36
22.	G4201-03	1	Hose, 2" x 18'
23.	G10619	6	Close Nipple, 1 1/4" NPT
24.	GA4976	5	Shutoff Valve, 1 1/4" NPT
	GR1015	-	Body O-Ring
	GR1016	-	Stem O-Ring
	GR1017	-	Teflon Seat
	GR1018	-	Ball
	GR1019	-	Handle
25.	G10719	2	Tee, 1 1/4" Female NPT
26.	G10674	-	Hose Clamp, No. 24
27.	G10626	6	Adapter, 1 1/4" NPT To Barb
28.	G4200-03	1	Hose, 1 1/4" x 32', 12 Row 30"
	G4200-06	-	Hose, 1 1/4" x 40', 16 Row 30"
29.	G10629	4	Elbow, 90°, 1 1/4" NPT To Barb
30.	G10616	2	Reducing Bushing, 2" Male NPT To 1 1/4" Female
31.	G10888	1	Tee, 2" Female NPT
32.	G10046	2	Hex Head Cap Screw, 5/8"-11 x 5"
	G10230	2	Lock Washer, 5/8"
	G10104	2	Hex Nut, 5/8"-11
33.	GD14522	1	Plate, 2" x 9 5/8"
34.	G10633	1	Tee, 1 1/4" Barb
35.	G10628	1	Adapter, 2" NPT To Barb
36.	GD11235	4	Hose Clamp, 2"
37.	G10203	4	Washer, 3/8" SAE
	G10108	4	Lock Nut, 3/8"-16

LIQUID FERTILIZER PISTON PUMP MOUNT/DRIVE

(TWL219w/D18960)

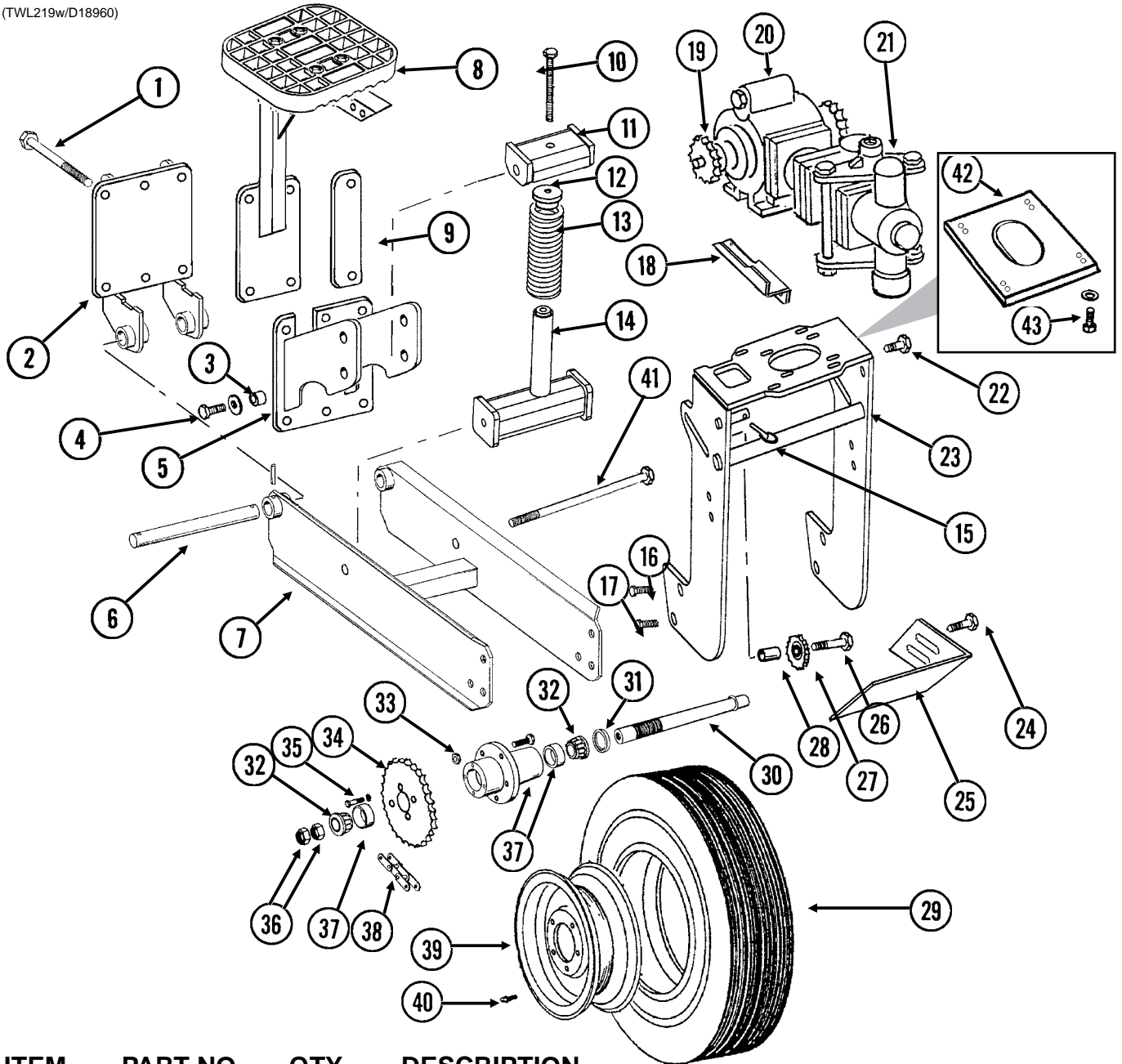

ITEM	PART NO.	QTY.	DESCRIPTION
1.	G10830	6	Hex Head Cap Screw, 5/8"-11 x 7 1/2"
	G10230	6	Lock Washer, 5/8"
	G10104	6	Hex Nut, 5/8"-11
2.	GA9711	1	Wheel Arm Mount
3.	GB0218	2	Bushing, 2 1/2" I.D. x 7/8" O.D. x 1 9/32" Long
4.	G10005	2	Hex Head Cap Screw, 5/8"-11 x 1 3/4"
	GD7805	2	Special Washer, 5/8", Hardened
	G10107	2	Lock Nut, 5/8"-11
5.	GA9712	1	Spring Mount
6.	GD2681	1	Pin, 1 1/4" x 13 1/2"
	G10460	2	Cotter Pin, 1/4" x 2"
7.	GA10621	1	Arm W/Grease Fittings
	G10641	2	Grease Fitting, 1/8" NPT
8.	-	-	See "Bulk Seed Hopper Catwalk", Pages P12 And P13
9.	GD13766	1	Spacer Plate (SDS Only)

LIQUID FERTILIZER PISTON PUMP MOUNT/DRIVE

ITEM	PART NO.	QTY.	DESCRIPTION
10.	G10012	1	Hex Head Cap Screw, 5/8"-11 x 6 1/2"
	GD7805	1	Special Washer, 5/8", Hardened
11.	GA10908	1	Spring Mount
12.	GB0196	1	Washer
13.	GD7831	1	Compression Spring
14.	GA10907	1	Spring Guide
15.	GD2558	1	Lynch Pin, 1/4"
16.	G10026	2	Hex Head Cap Screw, 3/4"-10 x 2"
	G10231	2	Lock Washer, 3/4"
17.	G11042	2	Hex Head Cap Screw, 3/4"-10 x 1 3/4"
	G10231	2	Lock Washer, 3/4"
	G10105	2	Hex Nut, 3/4"-10
18.	GD13744	1	Hose Holder
19.	GR1146	1	Sprocket, 18 Tooth
20.		-	See "Liquid Fertilizer Piston Pump (Crankcase Assembly)", Pages P152 And P153
	GR0200	1	Offset Link, No. 2050
21.		-	See "Liquid Fertilizer Piston Pump (Cylinder Assembly)", Pages P150 And P151
22.	G10007	2	Hex Head Cap Screw, 5/8"-11 x 1 1/2"
	G10217	2	Washer, 5/8" USS
	G10230	2	Lock Washer, 5/8"
	G10104	2	Hex Nut, 5/8"-11
23.	GA10893	1	Pump Mount
24.	G10017	2	Hex Head Cap Screw, 1/2"-13 x 1 1/2"
	G10216	2	Washer, 1/2" USS
	G10228	2	Lock Washer, 1/2"
	G10102	2	Hex Nut, 1/2"-13
25.	GD13328	1	Scraper
26.	G10013	1	Hex Head Cap Screw, 5/8"-11 x 3 1/2"
	G10205	1	Washer, 5/8" SAE
	G10230	1	Lock Washer, 5/8"
	G10104	1	Hex Nut, 5/8"-11
27.	GA0262	1	Idler Sprocket W/Bearing, 15 Tooth
28.	GD7817-05	1	Spacer, 1 1/16" I.D. x 1 1/4" Long
29.	GD0844	1	Tire, 7.60" x 15", 8 Ply (Specify Brand*)
30.	GA2559	1	Spindle
31.	GA0252	2	Seal
32.	GA0251	2	Bearing
33.	GR0267	5	Lug Nut, 1/2"-20
34.	G2500-84	1	Sprocket, 48 Tooth
35.	G10019	4	Hex Head Cap Screw, 5/16"-18 x 1"
	G10232	4	Lock Washer, 5/16"
36.	GD0831	2	Shoulder Nut, 1 1/4"-12 UNF-2A
37.	GA0547	1	Hub W/Cups And Studs, 5 Bolt
	GR0190	2	Cup
	GR0204	5	Stud
38.	G3200-59	1	Chain, No. 2050, 59 Pitch Including Connector Link And Offset Link, Used W/ Model L-4405 Piston Pump
	G3200-62	1	Chain, No. 2050, 62 Pitch Including Connector Link And Offset Link, Used W/Model NGP-7055 Piston Pump
	G3200-60	-	Chain, No. 2050, 59 Pitch
	GR0195	1	Connector Link, No. 2050
	GR0200	-	Offset Link, No. 2050
39.	GA0241	1	Wheel, 5" x 15"
40.	GD1166	1	Valve Stem
41.	G11122	1	Hex Head Cap Screw, 5/8"-11 x 12"
	G10107	1	Lock Nut, 5/8"-11
42.	GD18960	1	Adapter Plate (Used W/Model NGP-7055 Piston Pump - If Applicable)
43.	G10001	8	Hex Head Cap Screw, 3/8"-16 x 1
	G10203	4	Washer, 3/8" SAE

* Specific brand requests will be supplied only as available from current KINZE® Repair Parts stock. If a specific brand requested is not in stock, the brand available will be supplied. Different brand tires may have different diameters. Change in tire brand may affect rates. Field checks are recommended after any change in tires.

LIQUID FERTILIZER FLOW DIVIDER MOUNT AND HOSES

(FRTZ215cc/FRTZ297aa)

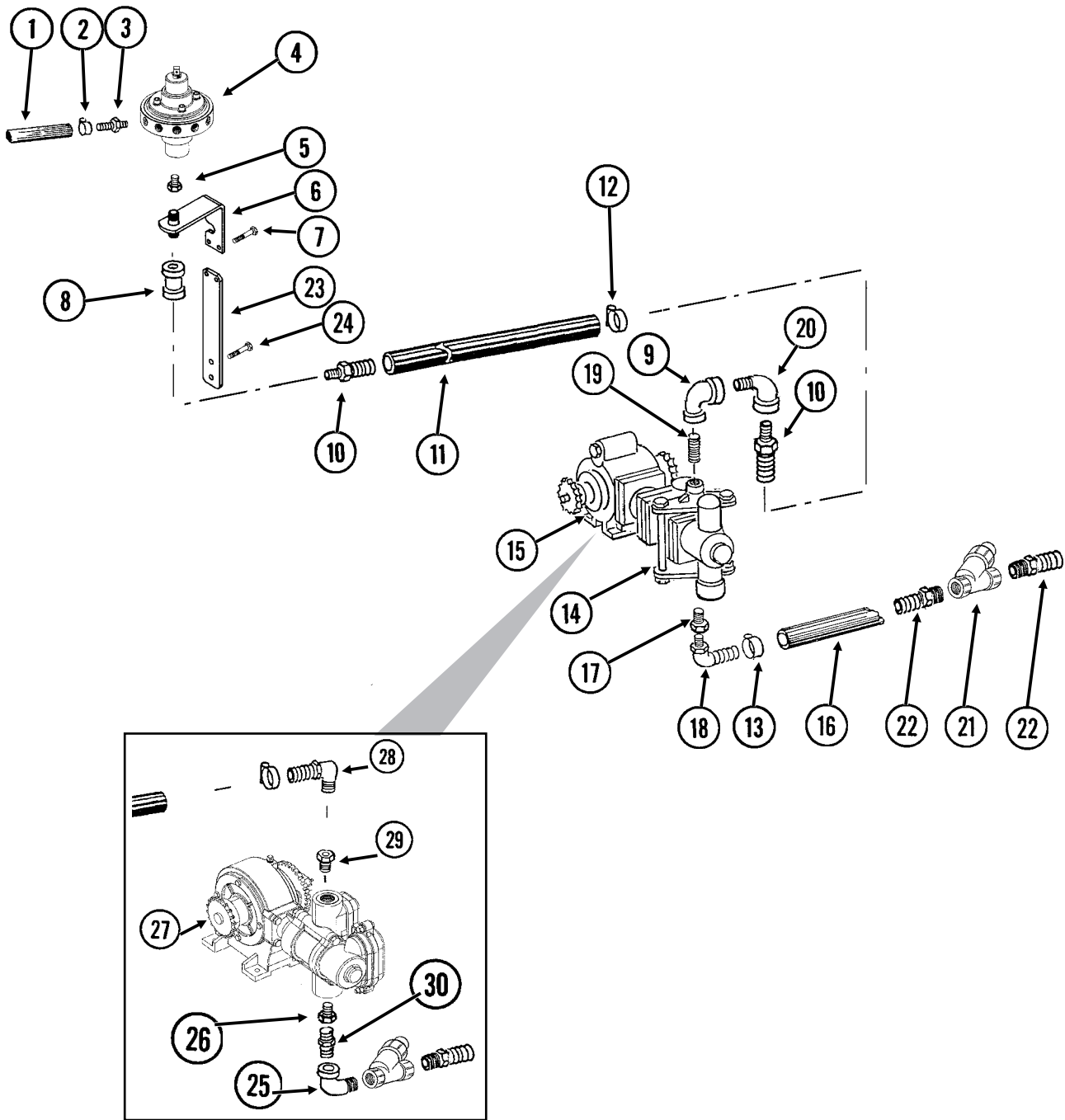

LIQUID FERTILIZER FLOW DIVIDER MOUNT AND HOSES

ITEM	PART NO.	QTY.	DESCRIPTION
1.	G4301-06	1	Hose, 3/8" x 160', 12 Row 30"
	G4301-05	2	Hose, 3/8" x 120', 16 Row 30"
2.	G10681	24-32	Hose Clamp, No. 6
3.	GD11700	12-16	Adapter, 1/4" NPT To 3/8" Barb
4.		-	See "Liquid Fertilizer Piston Pump Flow Dividers", Pages P156 And P157
5.	G10995	1	Reducing Bushing, 1" Male NPT To 3/4" Female, Stainless Steel, 16 Row 30"
6.	GA10110	1	Support, 3/4" NPT
7.	G10004	2	Hex Head Cap Screw, 3/8"-16 x 1 1/4"
	G10229	2	Lock Washer, 3/8"
	G10101	2	Hex Nut, 3/8"-16
8.	G11083	1	Coupler, 3/4" Female NPT
9.	G10733	1	Elbow, 90°, 3/4" Female NPT
10.	G10734	2	Adapter, 3/4" NPT To Barb
11.	G4205-10	-	Hose, 3/4" x 200"
12.	G10278	2	Hose Clamp, No. 16
13.	G10674	2	Hose Clamp, No. 24
14.		-	See "Liquid Fertilizer Piston Pump (Cylinder Assembly)", Pages P152 And P153
15.		-	See "Liquid Fertilizer Piston Pump (Crankcase Assembly)", Pages P150 And P151
16.		-	Hose, 1 1/4", See "Liquid Fertilizer Tanks, Saddles, Saddle Mounts And Hoses", Pages P142-P145
17.	G10615	1	Reducing Bushing, 1 1/2" Male NPT To 1 1/4" Female
18.	G10629	1	Elbow, 90°, 1 1/4" NPT To Barb
19.	G10389	1	Pipe Nipple, 3/4" NPT x 1 1/2" Long
20.	G10735	1	Elbow, 90°, 3/4" Male NPT To Female
21.	GA3893	1	Strainer Complete
	GR0880	-	Screen, No. 40 Mesh
	GR0881	-	Gasket
	GR0882	-	Y-Body
	GR0883	-	End Cap
22.	G10626	2	Adapter, 1 1/4" NPT To Barb
23.	GD16168	1	Extension
24.	G10037	2	Hex Head Cap Screw, 1/2"-13 x 1 1/4"
	G10228	2	Lock Washer, 1/2"
	G10102	2	Hex Nut, 1/2"-13
25.	G10887	1	Elbow, 90°, 1 1/4" Male NPT To Female
26.	G10615	1	Reducing Bushing, 1 1/2" Male NPT To 1 1/4" Female
27.		-	See "Liquid Fertilizer Piston Pump W/18 Tooth Sprocket", Pages 154 & 155
28.	G10917	1	Elbow, 90°, 3/4" NPT To Barb
29.	G11237	1	Reducing Bushing, 1 1/2" Male NPT To 3/4" Female
30.	G10619	1	Close Nipple, 1 1/4" NPT

LIQUID FERTILIZER PISTON PUMP (Crankcase Assembly)

(PT38a/GR1100)

John Blue® Model L-4405

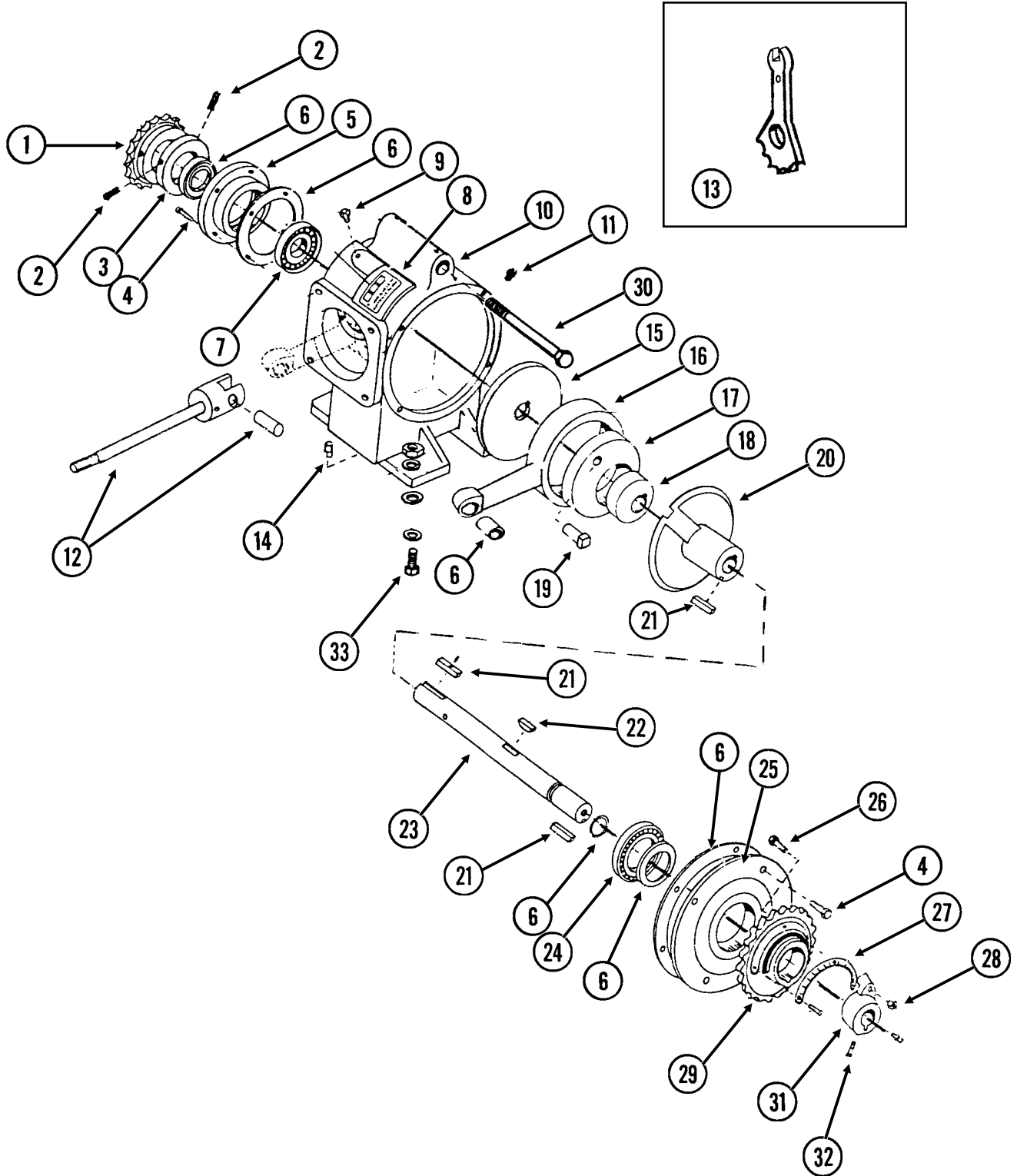

LIQUID FERTILIZER PISTON PUMP (Crankcase Assembly)

ITEM	PART NO.	QTY.	DESCRIPTION
1.		-	See "Liquid Fertilizer Piston Pump Mount/Drive", Pages P146 And P147
2.	G10688	2	Square Head Set Screw, 3/8"-16 x 5/8"
3.	GR1147	1	Spacer
4.	G10019	4	Hex Head Cap Screw, 5/16"-18 x 1"
5.	GR1102	1	Housing
6.	GR1173	-	Repair Kit, Includes Item 5 On "Liquid Fertilizer Piston Pump (Cylinder Assembly)", Pages P152 And P153
7.	GR1104	1	Bearing
8.	GR1105	1	Name Plate
9.	G10054	2	Hex Head Cap Screw, 5/16"-18 x 1/2"
10.	GR1106	1	Crankcase
11.	GR1107	1	Vent Plug
12.		-	See "Liquid Fertilizer Piston Pump (Cylinder Assembly)", Pages P152 And P153
13.	GR1100	1	Adjustment Wrench
14.	GR1123	3	Plug
15.	GR1108	1	Disc
16.	GR1109	1	Connecting Rod
17.	GR1110	1	Large Eccentric
18.	GR1111	1	Small Eccentric
19.	GR1120	1	Eccentric Pin
20.	GR1119	1	Sleeve
21.	GR1118	3	Setting Arm Key
22.	GR1112	1	Woodruff Key
23.	GR1148	1	Crankshaft
24.	GR1116	1	Bearing
25.	GR1166	1	Cover Plate
26.	GR1167	1	Square Head Cap Screw, 3/8"-16 x 1 3/4"
27.	GR1168	1	Scale
28.	G10108	1	Lock Nut, 3/8"-16
29.	GR1114	1	Flange
30.	G10318	1	Hex Head Cap Screw, 5/8"-11 x 4 1/2"
	G10104	1	Hex Nut, 5/8"-11
31.	GR1165	1	Arm
32.	G10693	4	Hex Socket Head Set Screw, 5/16"-18 x 3/8"
33.	G10003	4	Hex Head Cap Screw, 3/8"-16 x 1 1/2"
	GR1122	4	Mounting Pad
	G10210	8	Washer, 3/8" USS
	G10229	4	Lock Washer, 3/8"
	G10101	4	Hex Nut, 3/8"-16
A.	GA6154	1	Piston Pump Complete Less Sprocket (L-4405), Includes Crankcase (Items 2-33 On This Page) And Cylinder (Items 1-22 On Pages P152 And P153) Assemblies

LIQUID FERTILIZER PISTON PUMP (Cylinder Assembly)

(PT39a)

John Blue® Model L-4405

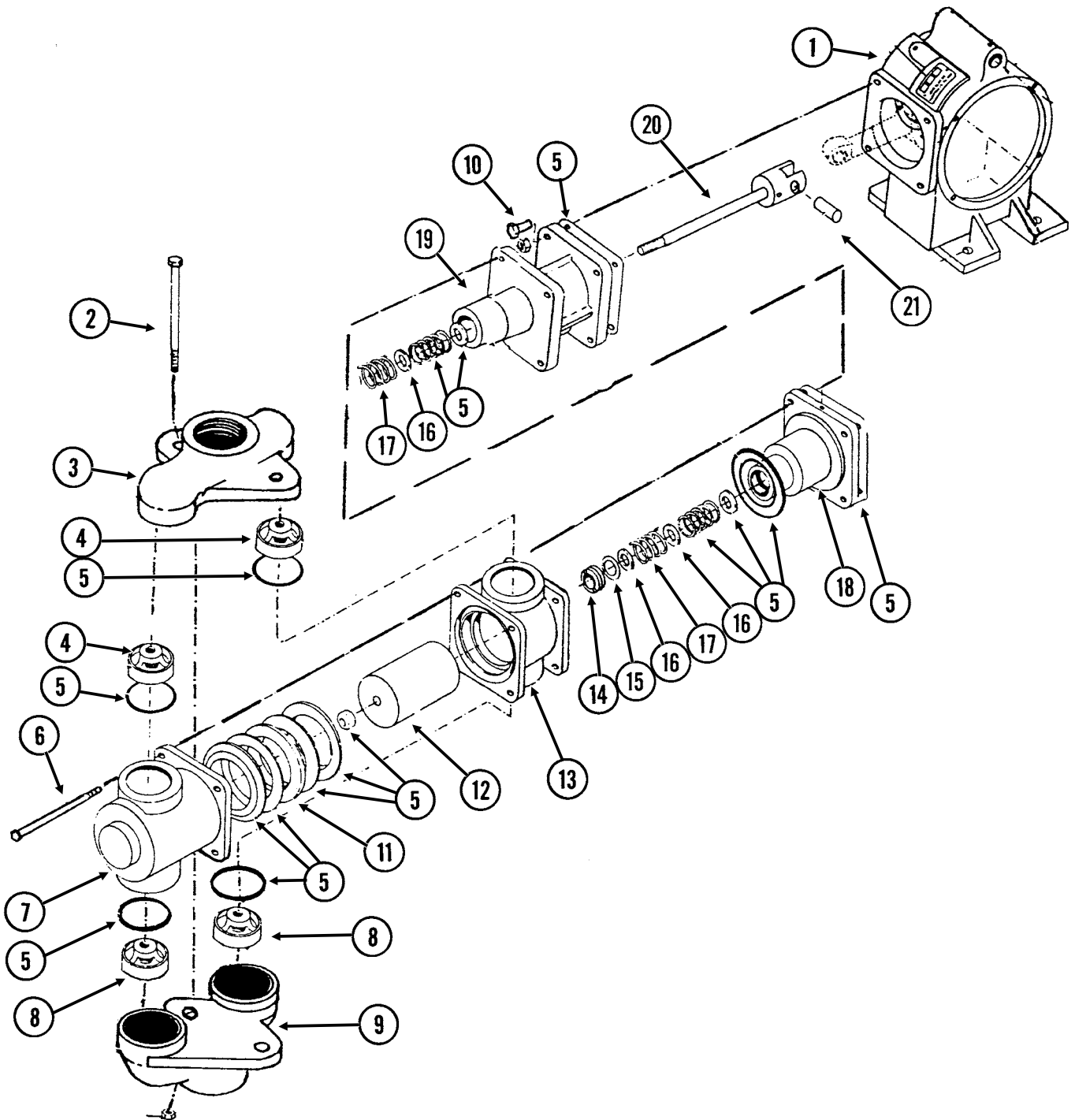

LIQUID FERTILIZER PISTON PUMP (Cylinder Assembly)

ITEM	PART NO.	QTY.	DESCRIPTION
1.		-	See "Liquid Fertilizer Piston Pump (Crankcase Assembly)", Pages P150 And P151
2.	G10686	2	Hex Head Cap Screw, 3/8"-16 x 8"
	G10101	2	Hex Nut, 3/8"-16
3.	GR1145	1	Discharge Manifold
4.	GR1144	2	Discharge Valve
5.	GR1173	-	Repair Kit, Includes Item 6 On "Liquid Fertilizer Piston Pump (Crankcase Assembly)", Pages P150 And P151
6.	G10687	4	Hex Head Cap Screw, 3/8"-16 x 5 1/2"
	G10101	4	Hex Nut, 3/8"-16
7.	GR1143	1	Outboard Cylinder
8.	GR1142	2	Suction Valve
9.	GR1140	1	Suction Manifold
10.	G10019	4	Hex Head Cap Screw, 5/16"-18 x 1"
11.	GR1137	1	Flange Packing Washer
12.	GR1136	1	Plunger
13.	GR1135	1	Inboard Cylinder
14.	GR1134	1	Stuffing Box Insert
15.	GR1133	1	Retaining Ring
16.	GR1129	3	Washer
17.	GR1130	2	Packing Spring
18.	GR1132	1	Outboard Stuffing Box
19.	GR1127	1	Crosshead Guide
20.	GR1125	1	Piston Rod
21.	GR1124	1	Pin

LIQUID FERTILIZER PISTON PUMP Uses 18 Tooth Sprocket

(A12335a/GR1808)

Model NGP-7055

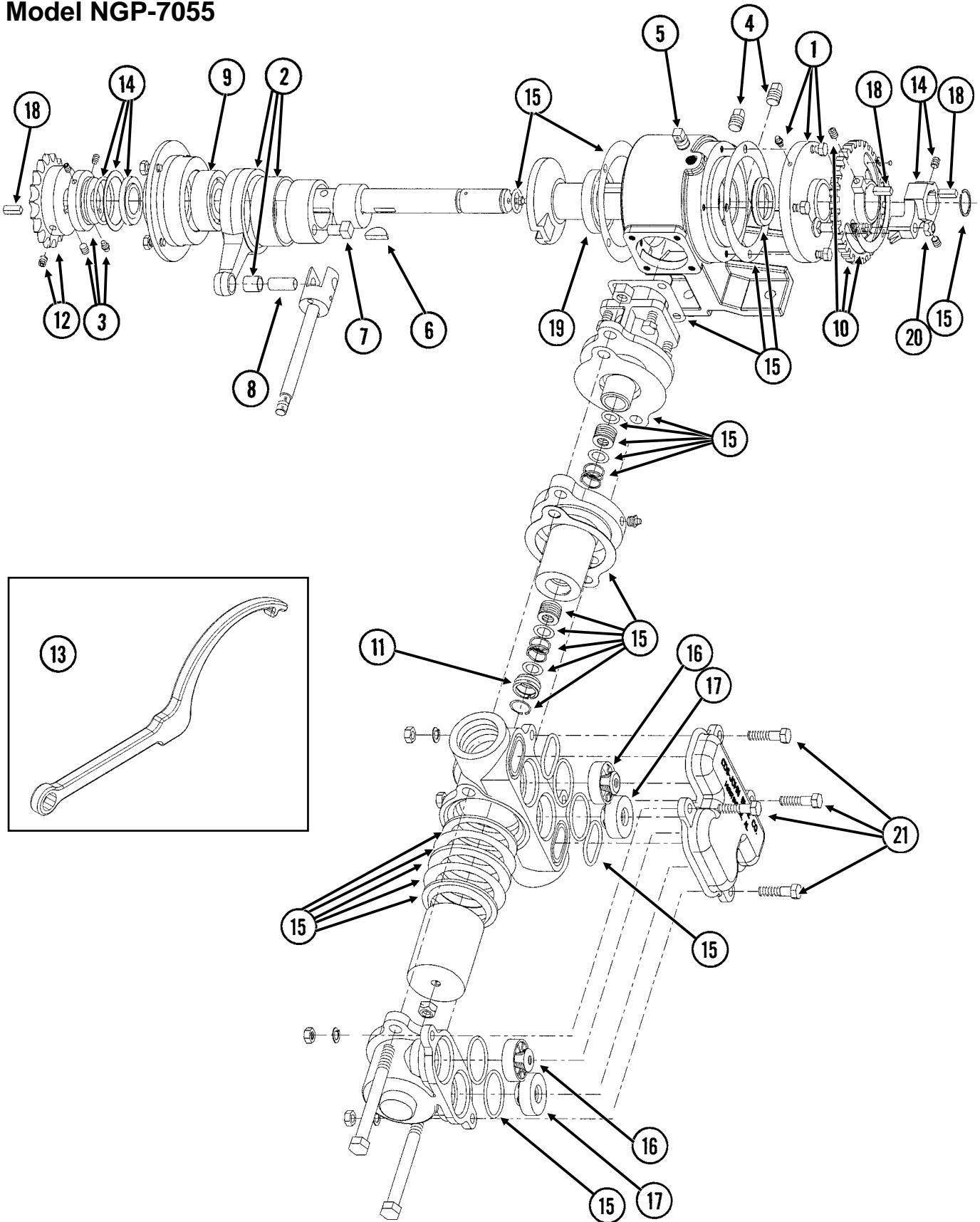

LIQUID FERTILIZER PISTON PUMP

Uses 18 Tooth Sprocket

ITEM	PART NO.	QTY.	DESCRIPTION
1.	GR1804	1	Flange Cover Assembly
	G10991	4	Hex Head Cap Screw, 5/16"-18 x 7/8"
2.	GR1803	1	Connecting Rod Assembly
3.	GR1801	1	Spacer Assembly
	G10693	3	Hex Socket Head Set Screw, 5/16"-18 x 3/8"
4.	GR1123	2	Plug
5.	GR1543	1	Vent Plug
6.	GR1112	1	Woodruff Key
7.	GR1120	1	Eccentric Pin
8.	GR1124	1	Pin
9.	GR1104	1	Bearing
10.	GR1805	1	Setting Hub Assembly
11.	GR1134	1	Stuffing Box Insert
12.	GR1146	1	Sprocket, 18 Tooth
13.	GR1808	1	Adjustment Wrench
14.	GR1806	1	Setting Pointer Assembly
15.	GR1796	1	Repair Kit, Includes: (6) Gaskets, (9) O-Rings, (4) Washers, (1) Retaining Ring, (2) Oil Seals, (1) Snap Ring, (1) Thrust Washer, (1) Rod Bushing, (2) Flange Plunger Packings, (2) Packing Springs, (2) Rod Vee Packing Sets
16.	GR1800	2	Discharge Valve Assembly
17.	GR1798	2	Suction Valve Assembly
18.	GR1118	3	Setting Arm Key
19.	GR1116	1	Bearing
20.	G10306	1	Carriage Bolt, 3/8"-16 x 2"
	G10108	1	Lock Nut, 3/8"-16
21.	G10003	4	Hex Head Head Cap Screw, 3/8"-16 x 1 1/2"
	G10210	4	Washer, 3/8" USS
	G10229	4	Lock Washer, 3/8"
	G10101	4	Hex Nut, 3/8"-16
A.	GA12335	-	Piston Pump Complete W/18 Tooth Sprocket (Model NGP-7055)

LIQUID FERTILIZER PISTON PUMP FLOW DIVIDERS

(FRTZ202a/FRTZ202c/FRTX202d)

12 Row 30"
Model FD-1200 Flow Divider,
12 Outlet

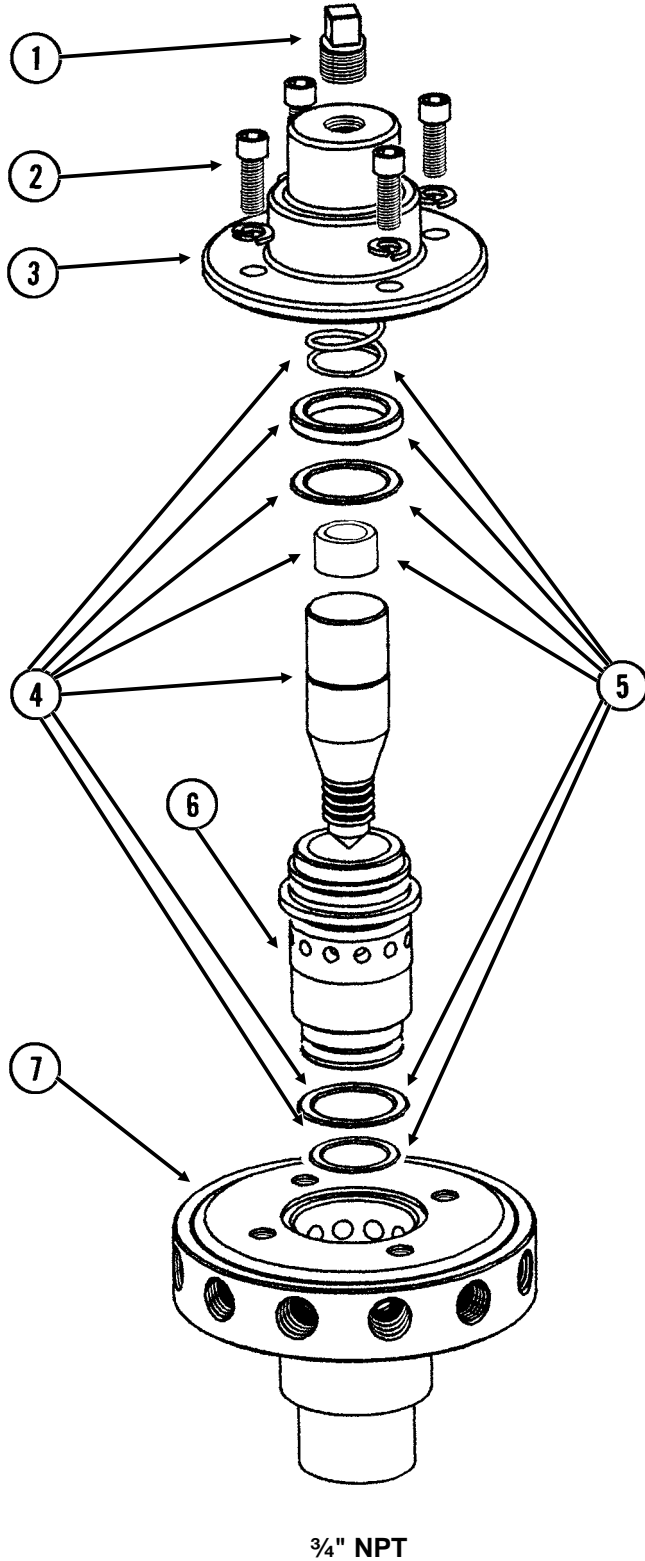

16 Row 30"
Model FD-2000 Flow Divider,
20 Outlet

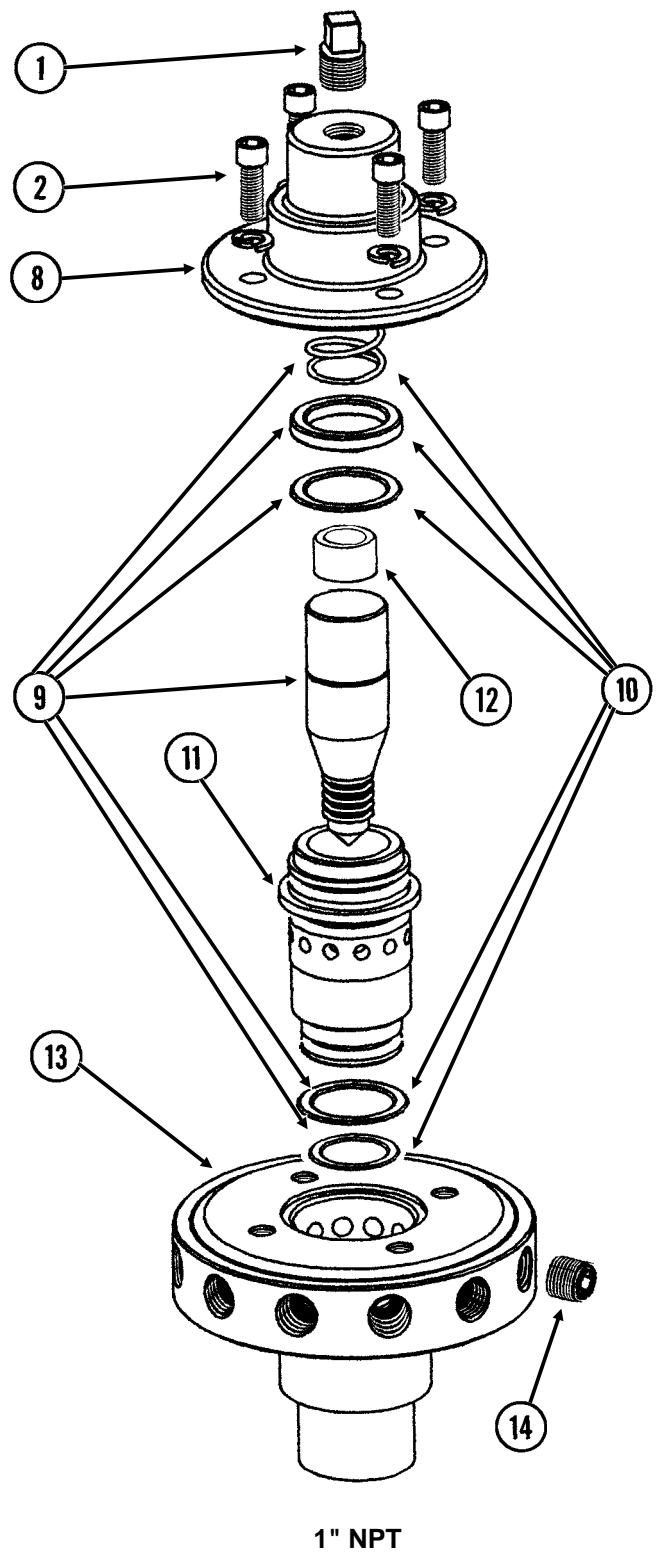

LIQUID FERTILIZER PISTON PUMP FLOW DIVIDERS

ITEM	PART NO.	QTY.	DESCRIPTION
1.	GR1543	1	Plug
2.	GR1542	4	Hex Socket Head Screw, 1/4"-20 x 3/4", Stainless Steel
	GR1541	4	Lock Washer, 1/4", Stainless Steel
3.	GR1540	1	Cap
4.	GR1544	1	Needle Assembly W/Seal Kit (Item 11)
5.	GR1545	1	Seal Kit, Includes: (3) O-Rings, (1) Seal, (1) Spring, (1) Stainless Steel Sleeve
6.	GR1535	1	Sleeve
7.	GR1533	1	Body (12 Outlet)
8.	GR1566	1	Cap
9.	GR1567	1	Needle Assembly W/Seal Kit (Item 11)
10.	GR1568	1	Seal Kit, Includes: (3) O-Rings, (1) Seal, (1) Spring
11.	GR1561	1	Sleeve
12.	GR1574	1	Sleeve, 1" O.D. x 1/2" Long, Stainless Steel
13.	GR1559	1	Body (20 Outlet)
14.	G10350	4	Hex Socket Head Plug, 1/4" NPT, Stainless Steel
A.	GA8931	1	Liquid Fertilizer Piston Pump Flow Divider Complete, 12 Outlet (Model FD-1200)
B.	GA9407	1	Liquid Fertilizer Piston Pump Flow Divider Complete, 20 Outlet (Model FD-2000)

REAR TRAILER HITCH

(A9895b)

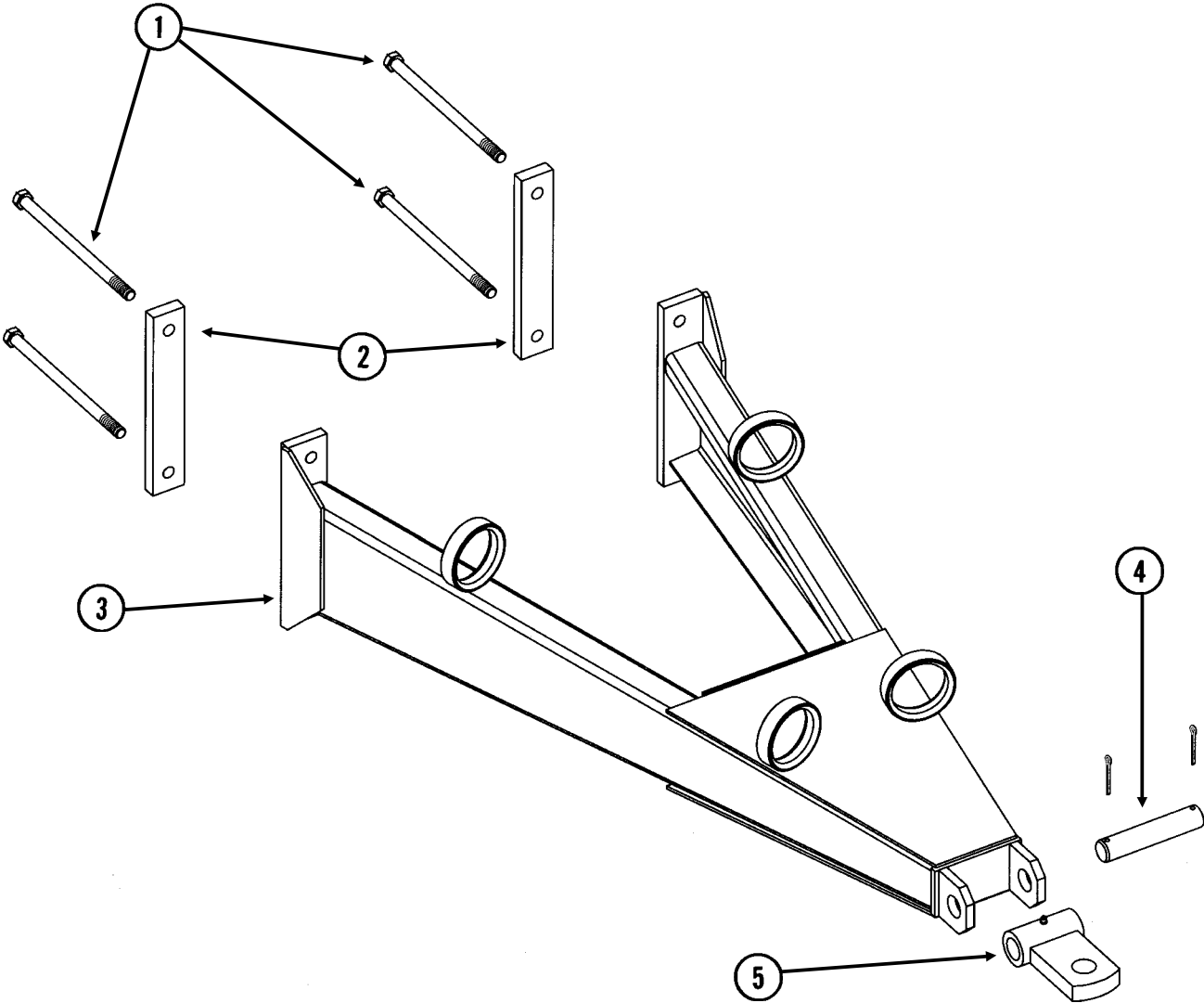

REAR TRAILER HITCH

ITEM	PART NO.	QTY.	DESCRIPTION
1.	G10668	4	Hex Head Cap Screw, 5/8"-11 x 11"
	G10230	4	Lock Washer, 5/8"
	G10104	4	Hex Nut, 5/8"-11
2.	GD14150	2	Clamp, 2" x 11 3/4"
3.	GA9896	1	Hitch
4.	GD8839	1	Pin, 1 1/4" x 6 1/4"
	G10460	2	Cotter Pin, 1/4" x 2"
5.	GA6177	1	Clevis W/Grease Fitting
	G10640	-	Grease Fitting, 1/4"-28

DECALS, PAINT AND MISCELLANEOUS



1



2



4



3



5

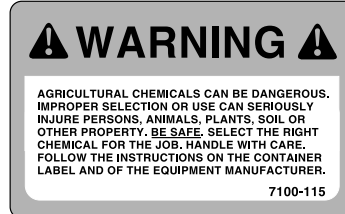

6

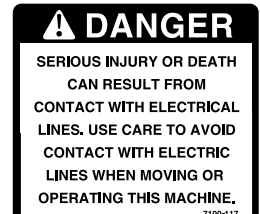

7



8

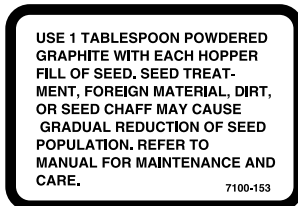

9



10



11

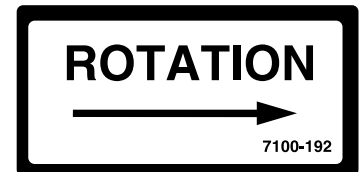

12



13

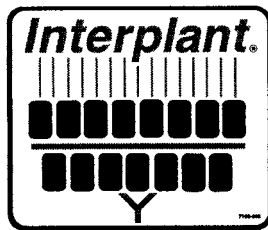

14

TRANSMISSION RATE REDUCTION

DRIVE	DRIVEN	% REDUCTION IN POPULATION
15	30	50
17	30	43
23*	30	23
24	30	20
25*	30	17
26*	30	13
27	30	10

* Use sprockets off seed drive transmission

7100-214

15



16

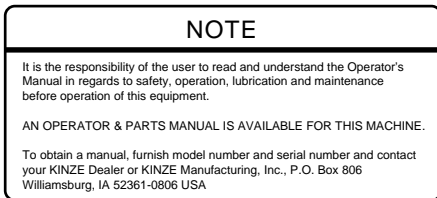

17



18



19

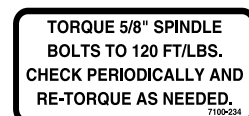

20



21

KINZE 3650

22



24



25



23

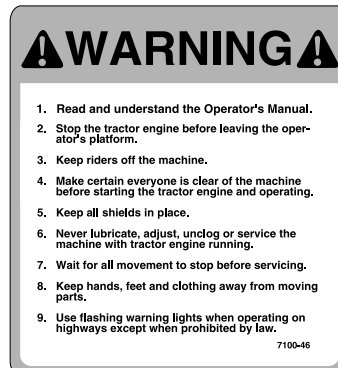

28

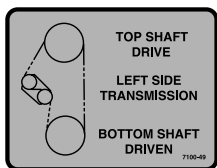

26



27

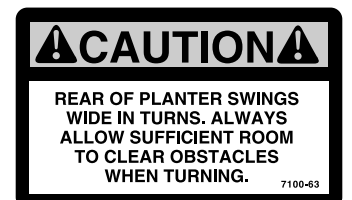

29

DECALS, PAINT AND MISCELLANEOUS

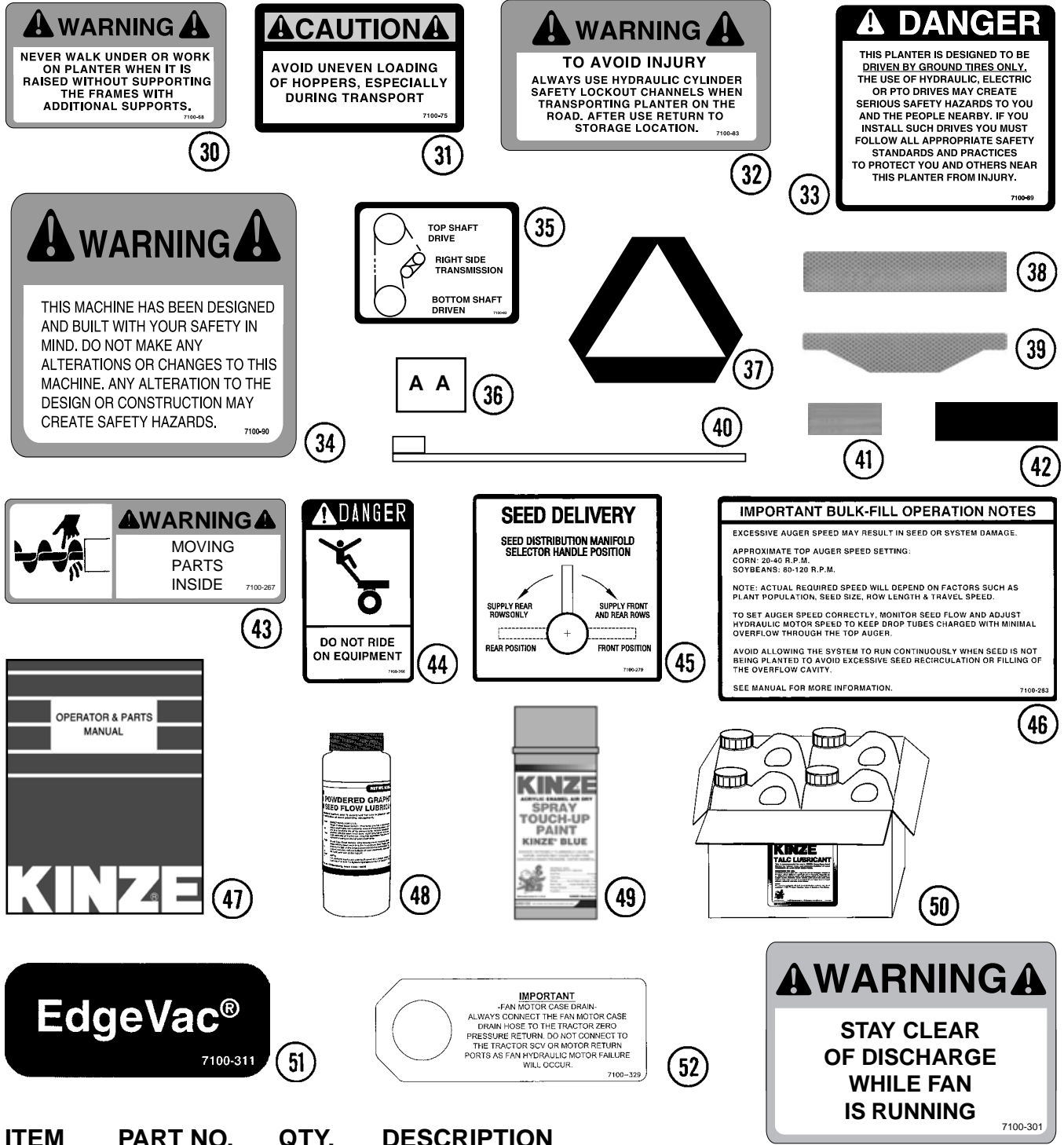

ITEM	PART NO.	QTY.	DESCRIPTION
1.	G7100-02	3	Decal, Warning
2.	G7100-110	-	Decal, Grease Weekly
3.	G7100-111	-	Decal, Oil Daily
4.	G7100-116	-	Decal, Grease Daily
5.	G7100-277	-	Decal, Grease Annually
6.	G7100-115	-	Decal, Warning (1 Per Granular Chemical Hopper)
7.	G7100-117	1	Decal, Danger
8.	G7100-172	-	Decal, Warning
9.	G7100-153	-	Decal, Information (1 Per Seed Meter)
10.	G7100-177	1	Decal, Twin-Line®, 3/4" x 3"
11.	G7100-200	-	Decal, Warning

DECALS, PAINT AND MISCELLANEOUS

ITEM	PART NO.	QTY.	DESCRIPTION
12.	G7100-192	-	Decal, Point Row Clutch Rotation
13.	G7100-201	1	Decal, Information
14.	G7100-208	-	Decal, Interplant®
15.	G7100-214	-	Decal, Two-Speed Point Row Clutch Rate Reduction
16.	G7100-215	1	Decal, Danger
17.	G7100-217	-	Decal, Note
18.	G7100-219	-	Decal, Warning
19.	GD13704-01	-	Foam Seal, 1/4" x 1/4" x 102"
	GD13705-02	-	Foam Seal, 1/2" x 1/2" x 11 3/4"
	GD13705-03	-	Foam Seal, 1/2" x 1/2" x 36"
20.	G7100-234	-	Decal, Bolt Torque
21.	G7100-247	-	Decal, Logo, 4 3/8" x 4 1/2" (2 Per Row Unit)
	G7100-252	-	Decal, Logo, 3 1/2" x 3 5/8" (Hopper Panel Extension)
22.	G7100-264	2	Decal, 3650
23.	G7100-249	-	Decal, Caution
24.	G7100-295	-	Decal, Spring Tension Release
25.	G7100-42	4	Decal, Warning
26.	G7100-49	1	Decal, Left Side Transmission
27.	G7100-302	1	Decal, Warning
28.	G7100-46	1	Decal, Warning
29.	G7100-63	2	Decal, Caution
30.	G7100-68	3	Decal, Warning
31.	G7100-75	4	Decal, Caution
32.	G7100-83	2	Decal, Warning (1 Per Marker Lockup)
33.	G7100-89	2	Decal, Danger
34.	G7100-90	1	Decal, Warning
35.	G7100-92	1	Decal, Right Side Transmission
36.	GD10057-01	-	Hose Identification Sleeve, Red AA
	GD10057-02	-	Hose Identification Sleeve, Red BB
	GD10057-03	-	Hose Identification Sleeve, Blue AA
	GD10057-04	-	Hose Identification Sleeve, Blue BB
	GD10057-05	-	Hose Identification Sleeve, Green AA
	GD10057-06	-	Hose Identification Sleeve, Green BB
	GD10057-11	-	Hose Identification Sleeve, Green PP
	GD10057-12	-	Hose Identification Sleeve, Green RR
	GD10057-13	-	Hose Identification Sleeve, Green CD
37.	GD2199	1	SMV Sign
38.	G7100-258	-	Reflective Decal, Red, 1 1/2" x 9", Rectangular (If Applicable)
	G7100-259	-	Reflective Decal, Amber, 1 1/2" x 9", Rectangular (If Applicable)
	G7100-260	-	Reflective Decal, Orange, 1 1/2" x 9", Rectangular (If Applicable)
39.	G7100-261	-	Reflective Decal, Red, 1 3/4" x 9", Die-Cut (If Applicable)
	G7100-262	-	Reflective Decal, Amber, 1 3/4" x 9", Die-Cut (If Applicable)
	G7100-263	-	Reflective Decal, Orange, 1 3/4" x 9", Die-Cut (If Applicable)
40.	GD1512	-	Tie Strap, 7 1/2"
	GD2117	-	Tie Strap, 14 1/2"
	GD1162	-	Tie Strap, 28"
	GD2984	-	Tie Strap, 34"
41.	G7100-276	-	Reflective Decal, Orange, 1" x 2 1/4", Rectangular
42.	GD13706-01	-	Anti-Slip Tape, 4" x 9"
	GD13706-03	-	Anti-Slip Tape, 4" x 16"
	GD13706-04	-	Anti-Slip Tape, 4" x 10"
	GD13706-05	-	Anti-Slip Tape, 4" x 42"
43.	G7100-267	-	Decal, Warning
44.	G7100-266	-	Decal, Danger
45.	G7100-279	-	Decal, Seed Delivery (Located On Underside Of Bulk Hopper Lid)
46.	G7100-283	-	Decal, Important (Located On Underside Of Bulk Hopper Lid)
47.	GM0186	-	Operator & Parts Manual, Model 3650 (EdgeVac® Seed Metering)
48.	GR0146MPP	-	Powdered Graphite, Twenty-Four 1 Pound Containers
49.	GR0155MPP	-	Blue Paint, Twelve Aerosol Cans
50.	GR1570MPP	-	Talc Lubricant, Four 8 Pound Containers
	GR1828	-	Talc Lubricant, 30 Pound Container
51.	G7100-311	-	Decal, EdgeVac®
52.	G7100-329	-	Tag, Fan Motor Case Drain
53.	G7100-301	-	Decal, Warning

NUMERICAL INDEX

Part No.	Page	Part No.	Page	Part No.	Page
*A1000.....	P115, P117	*A7603.....	P111, P113	G10010.....	P7, P21, P37,
*A1008.....	P114, P116	*A7609.....	P111, P113	P39, P135, P141
*A1018.....	P114, P116	*A8200.....	P111, P113	G10011...P39, P63, P87, P89, P139	
*A1020.....	P115, P117	*A8203.....	P111, P113	G10012.....	P147
*A1021.....	P114, P116	*A8206.....	P111, P113	G10013.....	P8, P147
*A1039.....	P115, P117	*A8216.....	P111, P113	G10014.....	P7, P39, P53, P57,
*A1044.....	P114, P117	*A8217.....	P111, P113	P59, P63, P67
*A1054.....	P114, P116	*A8218.....	P111, P113	G10016.....	P17, P53,
*A1073.....	P115, P117	*A8219.....	P111	P76, P131, P137
*A1098.....	P114, P116	*A8220.....	P111	G10017.....	P13, P16, P21, P33,
*A1129.....	P111, P113	*A8221.....	P115, P117	P53, P57, P59, P73,
*A1139.....	P111, P113	*A8222.....	P114, P117	P87, P89, P139, P147
*A1184.....	P111, P113	*A8223.....	P115	G10018.....	P7, P15, P23
*A1189.....	P115, P117	*A8272.....	P115, P117	G10019.....	P19, P21, P49, P90,
*A12027.....	P115, P117	*A8281.....	P51	P133, P147, P151, P153
*A12028.....	P111, P113	*A8282.....	P51	G10020.....	P17, P74, P129
*A12029.....	P111, P113	*A8286.....	P115	G10022.....	P73, P93, P94,
*A12030.....	P111, P113	*A8287.....	P115	P125, P127
*A1413.....	P115, P117	A10080.....	P59	G10023.....	P27, P51, P81, P83
*A1424.....	P115	A10089.....	P67	G10025.....	P67
*A1444.....	P111, P113	A10093.....	P59	G10026.....	P53, P63, P75, P147
*A1450.....	P115	A10759.....	P27	G10027.....	P71
*A1457.....	P115	A11969.....	P41	G10033.....	P13, P21, P35, P69
*A1463.....	P111, P113	A11971.....	P41	G10036.....	P17, P31, P73, P84
*A1464.....	P51	A7010.....	P53	G10037.....	P47, P61, P84, P149
*A1477.....	P111, P113	A7088.....	P53	G10038.....	P79
*A1489.....	P111, P113	A7524.....	P100	G10039.....	P33, P39, P75, P137
*A1491.....	P111, P113	A8775.....	P92	G10043.....	P19, P21, P59
*A3101.....	P114, P116	A8797.....	P95	G10045.....	P35, P133
*A3118.....	P111, P113	A9015.....	P96, P97	G10046.....	P39, P133, P139, P145
*A3128.....	P114, P116	A9018.....	P91	G10047.....	P3, P10, P17,
*A3133.....	P111, P113	A9069.....	P69	P77, P85, P139
*A3137.....	P111, P113	A9070.....	P69	G10048.....	P66
*A3152.....	P115, P117	A9072.....	P69	G10049.....	P17, P81, P89
*A3156.....	P111, P113	A9073.....	P69	G10050.....	P69
*A3161.....	P114, P116	A9467.....	P95	G10053.....	P79, P84
*A3163.....	P114, P116	D13169.....	P98	G10054.....	P23, P105, P151
*A3183.....	P111, P113	D13426.....	P98	G10061.....	P9, P45, P47, P101
*A3199.....	P111, P113	G10001.....	P4, P8, P10, P16, P17,	G10063.....	P43
*A3218.....	P114, P116	P21, P23, P41, P43,	G10064.....	P8, P69, P74, P85
*A3219.....	P114, P116	P50, P51, P61, P66,	G10069.....	P102
*A3220.....	P114, P116	P69, P126, P136, P147	G10096.....	P143, P145
*A3279.....	P51	G10002.....	P15, P27, P139	G10097.....	P59
*A3280.....	P51	G10003.....	P3, P17, P21, P23,	G10098.....	P59
*A3292.....	P115, P117	P29, P37, P151, P155	G10100.....	P137
*A3341.....	P111, P113	G10004.....	P10, P17, P23,	G10101.....	P4, P8, P41, P43,
*A3342.....	P111, P113	P41, P65, P66,	P45, P47, P50, P57, P65,
*A3343.....	P111, P113	P67, P69, P71,	P66, P69, P77, P81, P83,
*A3344.....	P115, P117	P77, P131, P137, P149	P96, P97, P126, P131,
*A3351.....	P51	G10005.....	P39, P50,	P133, P149, P151,
*A3366.....	P115, P117	P55, P135, P146	P153, P155
*A3369.....	P51	G10006.....	P35, P53, P59	G10102....	P15, P21, P35, P39, P47,
*A3371.....	P51	G10007.....	P5, P17, P39, P55,	P51, P53, P57, P67, P73,
*A3373.....	P51	P69, P136, P143, P147	P75, P76, P84, P87, P89,
*A3374.....	P51	G10008.....	P74	P90, P131, P133, P135,
*A6201.....	P51	G10009.....	P52, P87, P89	P139, P144, P147, P149

NUMERICAL INDEX

Part No.	Page	Part No.	Page	Part No.	Page
G10103.....	P69, P73, P74, P81, P83, P85, P125, P127	G10205.....	P17, P39, P43, P53, P71, P74, P135, P136, P137, P147	G10232.....	P13, P15, P25, P49, P59, P73, P77, P84, P102, P105, P131, P133, P139, P147
G10104.....	P4, P13, P17, P23, P41, P52, P53, P59, P66, P67, P69, P73, P84, P87, P89, P129, P133, P135, P137, P139, P143, P145, P146, P147, P151, P159	G10206.....	P13, P15, P37, P59, P61, P69, P79, P87, P89, P131, P139	G10233.....	P15, P16, P73, P77, P84, P131, P141
G10105.....	P53, P67, P75, P136, P143, P147	G10207.....	P3	G10234.....	P67
G10106.....	P13, P33, P49, P59, P73, P77, P84, P102, P105, P131	G10209.....	P25, P28, P29, P51, P76, P85	G10235.....	P74, P76, P85, P129
G10107.....	P8, P17, P31, P33, P39, P50, P53, P63, P65, P67, P73, P74, P79, P84, P133, P139, P146, P147	G10210.....	P3, P8, P9, P10, P15, P19, P21, P23, P27, P40, P41, P45, P47, P51, P61, P65, P69, P77, P85, P131, P133, P139, P151, P155	G10237.....	P137
G10108.....	P3, P9, P10, P17, P19, P23, P27, P41, P43, P51, P53, P57, P65, P66, P67, P69, P73, P83, P85, P89, P92, P93, P94, P101, P103, P136, P139, P145, P151, P155	G10211.....	P119, P121, P125, P127	G10243.....	P127
G10109.....	P7, P8, P19, P21, P35, P37, P39, P51, P90, P133	G10213.....	P5, P37, P39, P133	G10252.....	P25
G10110.....	P17, P25, P29, P51, P69, P129	G10216.....	P7, P15, P17, P19, P21, P33, P41, P47, P53, P57, P61, P67, P73, P75, P84, P87, P89, P131, P135, P137, P144, P147	G10253.....	P81
G10111.....	P8, P13, P15, P19, P21, P31, P33, P35, P39, P53, P57, P61, P65, P69, P79, P87, P89, P133, P137, P139	G10217.....	P17, P19, P21, P23, P50, P53, P55, P69, P139, P147	G10257.....	P28, P81
G10112.....	P39, P53	G10219.....	P13, P19, P23, P51, P131, P139	G10260.....	P25
G10118.....	P55	G10220.....	P136	G10278.....	P74, P143, P144
G10128.....	P16, P73, P84	G10221.....	P133	G10278.....	P149
G10130.....	P16, P77, P131	G10226.....	P53, P75, P87, P89	G10284.....	P41
G10131.....	P57, P76	G10227.....	P51, P69, P73, P74, P76, P81, P83, P85, P93, P94, P125, P127	G10301.....	P19
G10133.....	P8, P35, P37, P39, P105, P133	G10228.....	P7, P15, P17, P35, P47, P51, P53, P57, P59, P61, P67, P73, P75, P76, P84, P87, P89, P90, P131, P133, P135, P139, P144, P147, P149	G10303.....	P73, P77, P131
G10148.....	P51	G10229.....	P4, P8, P10, P16, P23, P27, P37, P41, P43, P45, P47, P50, P57, P61, P65, P66, P69, P77, P81, P83, P85, P96, P97, P99, P126, P131, P133, P137, P149, P151, P155	G10304.....	P3
G10157.....	P52, P53, P55	G10230.....	P4, P7, P8, P13, P21, P23, P41, P52, P53, P55, P59, P67, P69, P87, P89, P133, P135, P137, P139, P143, P145, P146, P147, P159	G10305.....	P19, P133
G10159.....	P63, P66, P69	G10231.....	P53, P63, P69, P75, P143, P147	G10306.....	P139, P155
G10168.....	P79, P90			G10308.....	P8
G10169.....	P52, P55			G10309.....	P9
G10171.....	P25, P51			G10312.....	P3, P16, P19, P27, P59, P69, P84
G10172.....	P65			G10315.....	P8, P15, P29
G10194.....	P37			G10318.....	P33, P151
G10201.....	P3, P17, P27, P40			G10322.....	P89, P137
G10203.....	P3, P41, P43, P65, P67, P81, P96, P97, P145, P147			G10323.....	P25
G10204.....	P5, P7, P133, P141			G10325.....	P5, P27

NUMERICAL INDEX

Part No.	Page	Part No.	Page	Part No.	Page
G10450.....	P139	G10620.....	P3, P7, P9,	G10827.....	P92, P100
G10451.....	P133	P27, P69, P135, P141	G10828.....	P67
G10453.....	P74	G10621.....	P9, P15, P27	G10829.....	P19
G10456.....	P41, P135	G10622.....	P5, P15, P16,	G10830.....	P41, P146
G10457.....	P53	P17, P21, P23	G10844.....	P90
G10459.....	P137	G10623.....	P143, P145	G10857.....	P85
G10460.....	P17, P59, P66,	G10626.....	P143, P145, P149	G10859.....	P81, P83
.....	P69, P75, P87,	G10628.....	P143, P145	G10860.....	P17, P73, P76, P79
.....	P89, P146, P159	G10629.....	P145, P149	G10862.....	P137
G10462.....	P52, P57, P77	G10630.....	P143, P145	G10864.....	P29
G10463.....	P15, P41	G10633.....	P143, P145	G10870.....	P17, P73, P76, P79
G10468.....	P57	G10636.....	P67, P75	G10871.....	P139
G10470.....	P85	G10640.....	P7, P17, P55, P60,	G10872.....	P83
G10473.....	P15	P67, P71, P87,	G10873.....	P83
G10496...P77, P81, P83, P85, P131		P89, P95, P135,	G10874.....	P13, P69
G10497.....	P81	P137, P139, P159	G10876.....	P83
G10499.....	P43, P133	G10641.....	P57, P87,	G10887.....	P143, P149
G10501.....	P15, P16,	P89, P136, P146	G10888.....	P143, P145
.....	P35, P73, P84	G10643.....	P39	G10889.....	P143, P145
G10503...P33, P37, P39, P79, P133		G10659.....	P17	G10890.....	P15, P73
G10504.....	P133	G10660.....	P28	G10894.....	P57
G10507.....	P136	G10668.....	P159	G10900.....	P81
G10509.....	P91, P96, P97	G10669.....	P3	G10907.....	P93, P94, P95
G10523.....	P29	G10670.....	P27	G10912.....	P5, P41
G10526.....	P135	G10674.....	P143, P145, P149	G10913.....	P60
G10527.....	P67, P76	G10676.....	P47, P143, P145	G10917.....	P143, P144, P149
G10535.....	P131	G10681.....	P45, P133, P149	G10918.....	P73, P129
G10536.....	P33, P87, P89	G10686.....	P153	G10921.....	P28
G10542.....	P133	G10687.....	P153	G10923.....	P16, P19,
G10543.....	P67	G10688.....	P77, P131, P151	P21, P77, P131
G10544.....	P90	G10689.....	P65	G10924.....	P7
G10546.....	P9, P28, P81, P85	G10693.....	P151, P155	G10927.....	P127
G10551.....	P3	G10718.....	P41	G10928.....	P105, P127
G10560.....	P135	G10719.....	P145	G10931.....	P127
G10567.....	P9, P27, P28	G10722.....	P90	G10932.....	P93, P94
G10570.....	P28	G10723.....	P92	G10938.....	P133
G10572.....	P33	G10724.....	P90	G10939.....	P92, P93, P94
G10574.....	P31, P35, P39	G10725.....	P90	G10940.....	P7
G10581.....	P65, P131	G10732.....	P4, P41	G10958.....	P93, P94, P95
G10583.....	P105	G10733.....	P149	G10961.....	P135, P414
G10585.....	P33, P57	G10734.....	P149	G10962.....	P100
G10592.....	P137	G10735.....	P149	G10967.....	P92
G10594.....	P137	G10743.....	P79	G10968.....	P131
G10595.....	P73, P85	G10751.....	P9, P41, P71	G10972.....	P91, P96, P97, P99
G10597.....	P33	G10752.....	P9	G10974.....	P37, P39
G10599.....	P8, P41, P43	G10753.....	P41, P43,	G10977.....	P105
G10600.....	P17	P96, P97, P103	G10979.....	P17, P89
G10602.....	P9, P15, P16,	G10757.....	P29, P127	G10990.....	P99
.....	P25, P27, P28,	G10758.....	P29, P127	G10991.....	P139, P155
.....	P73, P76, P79, P85	G10765.....	P37, P39, P53, P81, P83	G10995.....	P149
G10603.....	P25	G10770.....	P98	G10996.....	P81, P83,
G10606.....	P16	G10779.....	P17, P55	P108, P119, P121
G10610.....	P53, P75, P135	G10801.....	P8	G10999.....	P10
G10615.....	P149	G10802.....	P53	G11000.....	P21
G10616.....	P143, P145	G10804.....	P81, P83	G11007.....	P3
G10619.....	P143, P145, P149	G10809.....	P53	G11008.....	P3

NUMERICAL INDEX

Part No.	Page	Part No.	Page	Part No.	Page
G11009.....	P25	G1K268	P43, P119,	G3310-72.....	P15
G11010.....	P39	P121, P125, P127	G3310-74.....	P85
G11015.....	P3	G1K269.....	P77, P131	G3310-80.....	P77
G11016.....	P98	G1K274.....	P108	G3310-88.....	P16
G11017.....	P17, P19, P21, P23	G1K275.....	P108	G3400-01.....	P15, P16,
G11018.....	P71	G1K296.....	P7	P77, P84, P131
G11019.....	P71	G1K320.....	P123, P127	G4200-03.....	P143, P145
G11020.....	P21	G1K321.....	P123, P127	G4200-06.....	P143, P145
G11027.....	P17	G1K322.....	P127	G4201-03.....	P143, P145
G11034.....	P131	G1K323.....	P126	G4205-10.....	P149
G11042.....	P147	G1K324.....	P74	G4205-11.....	P143, P144
G11058.....	P53	G1K338.....	P17	G4301-05.....	P149
G11062.....	P129	G1K339.....	P17	G4301-06.....	P149
G11065.....	P106	G1K345.....	P8	G6325X	P4
G11066.....	P105	G1K362.....	P125, P127	G6400-06.....	P44, P45, P106
G11067.....	P105	G1K363.....	P125, P127	G6400-06-08	P111, P113,
G11068.....	P106	G1K364.....	P127	P114, P116
G11073.....	P28	G1K380.....	P77, P85	G6400-08.....	P93, P94, P103,
G11075.....	P77, P85	G1K381.....	P77, P85	P105, P106, P111,
G11077.....	P57	G1K385.....	P29	P113, P114, P116
G11078.....	P77, P85	G1K398.....	P15	G6400-08-04	P99, P114, P116
G11081.....	P75	G1K412.....	P53	G6400-08-10	P105
G11083.....	P149	G1K426.....	P44	G6400-10.....	P45, P51, P105, P106
G11084.....	P67	G1K467.....	P37	G6400-10-08	P101
G11098.....	P37	G2100-03.....	P77, P84, P131	G6400-10-12	P45
G11100.....	P76, P85	G2403-06.....	P111, P113	G6400-12.....	P44, P45, P51
G11109.....	P67	G2403-08.....	P114, P117	G6400-L-08	P114, P116
G11122.....	P147	G2403-10.....	P111, P113	G6405-08-06	P92
G11124.....	P43	G2403-12.....	P111, P113	G6408-06.....	P45, P93, P94,
G11125.....	P67	G2406-08-06	P114, P116	P96, P97, P103, P105
G11127.....	P15	G2500-84.....	P147	G6408-10.....	P105
G11133.....	P43	G2501-12-16	P51	G6408-12.....	P45
G11137.....	P123	G2501-16-20	P51	G6408-H06-O.....	P105, P106
G11147.....	P47	G2603-08.....	P114, P116	G6500-06.....	P44, P106
G11158.....	P51	G2700-06-06	P111, P113	G6500-08.....	P114, P116
G11159.....	P123	G2700-08.....	P99, P111, P113	G6500-10.....	P45
G11172.....	P25	G2700-10.....	P111, P113	G6500-12.....	P51
G11173.....	P25	G2704-08.....	P114, P117	G6502-06.....	P111, P113
G11177.....	P67	G304-C-10.....	P115	G6502-08.....	P114, P116
G11182.....	P143	G306-06.....	P111, P113	G6502-10.....	P101
G11182.....	P145	G306-08.....	P99, P111,	G6502-12.....	P44, P51
G11188.....	P47, P49	P113, P114, P117	G6600-08.....	P115, P117
G11209.....	P29	G306-10.....	P111, P113	G6602-08.....	P114, P116
G11210.....	P25	G3200-59.....	P147	G6602-10.....	P101
G11213.....	P25	G3200-62.....	P147	G6801-06.....	P106
G11215.....	P43	G3302-09.....	P50	G6801-06-08	P96, P97,
G11222.....	P9	G3303-100.....	P41	P11, P113
G11223.....	P55	G3303-108.....	P3, P28	G6801-08.....	P102, P104,
G11228.....	P37	G3303-16.....	P3	P106, P114, P116
G11236.....	P37	G3310-100.....	P79, P85	G6801-08-10	P105
G11237.....	P149	G3310-102.....	P131	G6801-10.....	P51, P115
G1K215	P135	G3310-114.....	P73	G6801-10-08	P101
G1K248	P119, P121, P125, P127	G3310-118.....	P73	G6801-10-12	P44, P50
G1K249	P127	G3310-126.....	P73	G6801-12-10	P51
G1K252	P119, P121, P125, P127	G3310-144.....	P131	G6801-16.....	P50
G1K267	P119, P121, P125, P127	G3310-226.....	P131	G6801-LL-08	P103

NUMERICAL INDEX

Part No.	Page	Part No.	Page	Part No.	Page
G6801-LL-10	P115	GA0167	P90	GA10195	P121
G6804-12	P51	GA0237	P136	GA10206	P121
G6804-12-12-08	P51	GA0241	P147	GA10547	P119, P121
G7100-02	P161	GA0243	P90	GA10553	P60
G7100-110	P161	GA0245	P90	GA10555	P121
G7100-111	P161	GA0251	P147	GA10556	P121
G7100-115	P161	GA0252	P147	GA10557	P59
G7100-116	P161	GA0257	P90	GA10558	P59
G7100-117	P161	GA0262	P147	GA10570	P125
G7100-153	P161	GA0312	P133	GA10575	P127
G7100-172	P161	GA0328	P133	GA10579	P21
G7100-177	P161	GA0378	P74	GA10580	P19
G7100-192	P162	GA0547	P147	GA10581	P19
G7100-200	P161	GA0810	P133	GA10583	P23
G7100-201	P162	GA0895	P75	GA10587	P23
G7100-208	P162	GA0899	P90	GA10590	P15
G7100-214	P162	GA10034	P145	GA10591	P15
G7100-215	P162	GA10035	P145	GA10592	P15
G7100-217	P162	GA10036	P141	GA10596	P131
G7100-219	P162	GA10037	P141	GA10597	P131
G7100-234	P162	GA10054	P81	GA10598	P131
G7100-247	P162	GA10065	P13	GA10599	P131
G7100-249	P162	GA10066	P13	GA10601	P125, P127
G7100-252	P162	GA10067	P13	GA10621	P146
G7100-258	P162	GA10070	P59	GA10634	P11
G7100-259	P162	GA10071	P59	GA10635	P43
G7100-260	P162	GA10072	P67	GA10671	P15
G7100-261	P162	GA10073	P67	GA10688	P23
G7100-262	P162	GA10077	P59	GA10699	P17
G7100-263	P162	GA10085	P71	GA10721	P19
G7100-264	P162	GA10090	P65	GA10722	P19
G7100-266	P162	GA10092	P71	GA10725	P21
G7100-267	P162	GA10094	P93, P94	GA10752	P43
G7100-276	P162	GA10096	P94	GA10755	P25
G7100-277	P161	GA10097	P94	GA10764	P21
G7100-279	P162	GA10099	P93	GA10765	P43
G7100-283	P162	GA10100	P93	GA10783	P47
G7100-295	P162	GA10101	P119, P121	GA10784	P47
G7100-301	P162	GA10102	P119, P121	GA10799	P43
G7100-302	P162	GA10104	P67	GA10828	P87
G7100-311	P162	GA10109	P144	GA10829	P89
G7100-329	P162	GA10110	P149	GA10832	P76
G7100-42	P162	GA10111	P13	GA10833	P145
G7100-46	P162	GA10112	P65	GA10834	P145
G7100-49	P162	GA10119	P133, P139	GA10835	P145
G7100-63	P162	GA10131	P61	GA10893	P147
G7100-68	P162	GA10137	P9	GA10907	P147
G7100-75	P162	GA10139	P60	GA10908	P147
G7100-83	P162	GA10148	P43	GA10917	P51
G7100-89	P162	GA10149	P44	GA10918	P51
G7100-90	P162	GA10155	P9	GA10919	P50
G7100-92	P162	GA10157	P3	GA10924	P123
G7633X	P119	GA10161	P41	GA10947	P92
G7639X	P119	GA10191	P121	GA10964	P23
G7698X	P69	GA10192	P121	GA10969	P23
G7830X	P121	GA10194	P121	GA10971	P23

NUMERICAL INDEX

Part No.	Page	Part No.	Page	Part No.	Page
GA10972	P23	GA12191	P73	GA4995	P52
GA10985	P15	GA12192	P73	GA5105	P15, P76, P85
GA10989	P49	GA12201	P13	GA5106	P76, P85, P131
GA10990	P49	GA12207	P13	GA5107	P76, P131
GA11039	P127	GA12208	P13	GA5108	P15, P76, P85
GA11079	P55	GA12235	P37, P39	GA5109	P76, P85
GA11082	P55	GA12236	P35, P37, P39	GA5110	P76, P85
GA11083	P55	GA12256	P37	GA5111	P76, P85
GA11154	P43	GA12335	P155	GA5112	P76, P85
GA11155	P43	GA12510	P15	GA5113	P73, P76, P79, P84
GA11156	P43	GA12802	P51	GA5114	P73
GA11159	P43	GA1676	P90	GA5116	P15
GA11160	P43	GA1677	P90	GA5121	P67, P73
GA11332	P49	GA1678	P90	GA5130	P87
GA11333	P49	GA1679	P90	GA5164	P74
GA11339	P43	GA1720	P4, P41	GA5165	P74
GA11341	P49	GA2007	P9, P41	GA5194	P79
GA11344	P131	GA2012L	P5	GA5223	P15
GA11345	P131	GA2012R	P5	GA5385	P119, P121
GA11392	P10	GA2014	P5, P33, P35, P37, P39, P129, P133	GA5531	P92
GA11397	P139	GA2068	P73	GA5548	P77
GA11398	P139	GA2148	P75	GA5549	P127
GA11520	P31	GA2180	P77, P131	GA5600	P126
GA11523	P51	GA2528	P119, P121	GA5625	P31
GA11528	P53	GA2559	P147	GA5651	P4
GA11544	P51	GA2612	P119, P121	GA5654	P33, P35, P37, P39
GA11568	P89	GA2660	P143, P145	GA5698	P25
GA11569	P89	GA2908	P75	GA5715	P33
GA11590	P87	GA3072	P121	GA5718	P33
GA11699	P43	GA3407	P108	GA5719	P33
GA11766	P87	GA3413	P108	GA5786	P41
GA11767	P87	GA3552	P74	GA5787	P41
GA11768	P89	GA3553	P73	GA5842	P52
GA11769	P89	GA3584	P118, P120	GA5853	P90
GA11911	P25	GA3893	P149	GA5887	P136
GA11916	P15	GA4286	P136	GA6108	P119, P121
GA11934	P45	GA4287	P136	GA6109	P119, P121
GA11935	P25	GA4293	P45, P109	GA6147	P127
GA11947	P125, P127	GA4353	P87	GA6154	P151
GA11948	P125, P127	GA4376	P75	GA6171	P7, P8, P135, P141
GA11957	P92	GA4377	P75	GA6177	P159
GA11962	P17	GA4402	P52	GA6189	P13
GA11980	P92	GA4418	P53	GA6344	P135
GA11987	P43	GA4444	P27	GA6345	P135
GA12108	P139	GA4611	P87	GA6434	P8
GA12109	P139	GA4722	P60	GA6497	P67
GA12117	P41	GA4723	P60	GA6597	P8
GA12133	P25	GA4729	P60	GA6699	P119, P121
GA12143	P9	GA4842	P53	GA6700	P119, P121
GA12144	P9	GA4845	P52	GA6741	P29
GA12150	P49	GA4877	P89	GA6832	P35
GA12151	P43	GA4878	P89	GA6833	P35
GA12154	P25	GA4976	P143, P145	GA6834	P35
GA12163	P55	GA4983	P89	GA6838	P35
GA12164	P55	GA4994	P52	GA6907	P29
GA12165	P55				

NUMERICAL INDEX

Part No.	Page	Part No.	Page	Part No.	Page
GA6966	P139	GA7856	P43, P119,	GA8983	P133, P137, P139
GA6975	P119, P121		P121, P125, P126	GA9012	P96, P97
GA6977	P119, P121	GA7857	P125, P127	GA9013	P96, P97
GA6978	P119, P121	GA7858	P126, P127	GA9016	P96
GA7016	P53	GA7862	P119, P121	GA9088	P87, P89
GA7021	P65	GA7863	P119, P121	GA9095	P105
GA7022	P53, P71	GA7949	P7	GA9097	P105
GA7029	P52	GA7975	P7	GA9098	P106
GA7042	P87	GA7976	P7	GA9105	P41
GA7043	P89	GA7997	P75	GA9126	P109
GA7050	P65	GA8026	P126	GA9128	P101
GA7051	P77	GA8046	P125, P127	GA9131	P39
GA7052	P77	GA8047	P119, P121,	GA9134	P97
GA7077	P119		P125, P127	GA9138	P131
GA7083	P52	GA8092	P131	GA9144	P127
GA7084	P52	GA8157	P95	GA9157	P17
GA7085	P52	GA8170	P87, P89	GA9158	P17
GA7096	P71	GA8305	P135	GA9159	P21
GA7110	P81	GA8306	P135	GA9160	P17
GA7111	P81	GA8320	P95	GA9175	P21
GA7118	P89	GA8322	P8	GA9191	P23
GA7137	P81	GA8324	P5	GA9192	P23
GA7154	P15, P16, P73,	GA8326	P28	GA9193	P23
	P79, P84, P131	GA8328	P43	GA9194	P23
GA7180	P17	GA8329	P43	GA9195	P133
GA7221	P91	GA8364	P28	GA9196	P21
GA7239	P137	GA8371	P27	GA9202	P119, P121
GA7240	P137	GA8393	P81, P83	GA9204	P119, P121
GA7271	P37	GA8483	P133	GA9205	P98
GA7274	P83	GA8603	P31, P39, P63, P139	GA9395	P16
GA7287	P129	GA8641	P31, P39, P63	GA9404	P19
GA7306	P85	GA8677	P75	GA9407	P157
GA7313	P77, P85	GA8685	P133	GA9433	P139
GA7317	P85	GA8688	P137	GA9434	P139
GA7319	P85	GA8689	P137	GA9437	P139
GA7320	P85	GA8729	P119	GA9468	P95
GA7321	P85	GA8731	P119, P121	GA9472	P141
GA7336	P77, P85	GA8734	P119	GA9479	P81, P83
GA7372	P74	GA8735	P119	GA9480	P81, P83
GA7412	P37	GA8760	P37	GA9481	P119, P121
GA7423	P57	GA8845	P133	GA9482	P81, P83
GA7424	P57	GA8857	P99	GA9483	P81, P83
GA7433	P53	GA8858	P99	GA9510	P105
GA7434	P60, P75	GA8859	P99	GA9544	P60
GA7445	P37, P39	GA8861	P99	GA9553	P16, P73
GA7446	P35, P37, P39	GA8862	P99	GA9554	P16, P73
GA7463	P83	GA8871	P100	GA9557	P79
GA7533	P53	GA8877	P135, P141	GA9558	P79
GA7579	P66	GA8882	P93, P94, P96, P97	GA9559	P98
GA7841	P15, P16	GA8893	P99	GA9571	P83
GA7845	P143, P145	GA8895	P100	GA9572	P83
GA7851	P125, P127	GA8909	P95	GA9588	P19
GA7852	P125, P127	GA8930	P41	GA9618	P71
GA7853	P125, P127	GA8931	P157	GA9621	P21
GA7854	P125, P127	GA8978	P99	GA9625	P16
GA7855	P125, P127	GA8979	P99	GA9671	P143

NUMERICAL INDEX

Part No.	Page	Part No.	Page	Part No.	Page
GA9682	P13	GB0268	P8	GD0914-76	P130
GA9683	P13	GB0274	P3	GD0962	P133
GA9684	P13	GB0276	P7	GD10007	P79
GA9685	P13	GB0278	P9, P28	GD10011	P71
GA9689	P123	GB0282	P8	GD10012	P71
GA9711	P146	GB0285	P3	GD10013	P71
GA9712	P146	GB0287	P77	GD10014	P71
GA9836	P52	GB0292	P53	GD10036	P4
GA9837	P53	GB0296	P139	GD10053	P66
GA9840	P69	GB0297	P139	GD10057-01	P162
GA9842	P91	GB0301	P5, P41	GD10057-02	P162
GA9843	P74	GB0307	P17	GD10057-03	P162
GA9844	P39	GB0308	P17	GD10057-04	P162
GA9845	P39	GB0309	P69	GD10057-05	P162
GA9846	P73	GB0312	P21	GD10057-06	P162
GA9848	P17	GB0313	P21	GD10057-11	P162
GA9857	P126	GB0314	P9, P41	GD10057-12	P162
GA9859	P17	GB0315	P13, P61	GD10057-13	P162
GA9861	P39	GB0319	P25	GD10064	P59
GA9862	P39	GB0322	P139	GD10068	P81, P83
GA9864	P39	GB0323	P139	GD10069	P81, P83
GA9865	P39	GB0324	P63	GD10070	P81
GA9896	P159	GB0328	P25	GD10071	P81
GA9902	P69	GB0331	P9	GD10099	P74
GA9903	P69	GB0352	P15	GD10100	P76
GA9905	P143	GB0353	P15	GD10102	P81
GA9918	P84	GB0358	P25	GD10103	P81, P83
GA9952	P129	GB0371	P10	GD10104	P81
GA9953	P129	GB0375	P10	GD10110	P143
GA9954	P129	GB0383	P37	GD10120	P83
GA9964	P43	GB0387	P35, P37	GD10123	P81, P83
GA9965	P121	GB0400	P139	GD10128	P75
GA9977	P17	GB0401	P37	GD10144	P75
GA9978	P125, P127	GB0405	P139	GD10207	P100
GA9979	P125, P127	GB0409	P67	GD10211	P93
GA9996	P61	GD0453-05	P87, P89	GD10242	P137
GA9999	P63	GD0487	P133	GD10243	P119, P121
GB0115	P28	GD0535	P66	GD1026	P3, P27, P40, P77, P85, P139
GB0116	P28	GD0652	P87, P89	GD10273	P137
GB0134	P133	GD0737	P89	GD10282	P83
GB0186	P4	GD0746	P90	GD10283	P90
GB0196	P147	GD0752-41	P17, P87	GD10298	P73
GB0205	P136	GD0752-47	P69	GD10303	P137
GB0206	P136	GD0826	P69	GD10304	P137
GB0212	P135	GD0831	P147	GD1033	P3
GB0213	P136	GD0840	P90	GD10355	P85
GB0218	P4, P9, P39, P41, P53, P65, P67, P74, P136, P146	GD0844	P147	GD10356	P76, P84
GB0237	P52	GD0914-106.5	P77	GD10366	P85
GB0239	P8	GD0914-124	P130	GD10473	P5, P17, P129
GB0246	P57	GD0914-138	P130	GD10487	P137
GB0254	P8	GD0914-166.75	P77	GD10510	P81, P83
GB0265	P3	GD0914-30	P131	GD10519	P37, P39
GB0266	P3	GD0914-35	P77	GD10526	P37
GB0267	P3	GD0914-45	P77	GD10530	P57
		GD0914-48	P130	GD10531	P67
		GD0914-66	P130		

NUMERICAL INDEX

Part No.	Page	Part No.	Page	Part No.	Page
GD10538-01	P57	GD11279	P11	GD12665	P96, P97
GD10543	P81, P85	GD11297	P28	GD12676	P139
GD10552	P35, P37, P39	GD11305	P27	GD12677	P139
GD10578	P83	GD11306	P5, P133	GD12679	P139
GD10579	P83	GD1132	P33, P35, P37, P39, P133	GD12685	P139
GD10584	P83	GD1138	P47, P87, P89, P144	GD12703	P69
GD10585	P83	GD11413	P9, P28	GD12724	P69
GD10586	P83	GD11422	P4	GD12726	P118, P120
GD10587	P83	GD11423	P7, P135, P141	GD12758	P103
GD10588	P83	GD11424	P27	GD12774	P67
GD1059L	P27	GD11447	P41	GD12797-01	P10
GD1059R	P27	GD11453	P7	GD12797-08	P10
GD1060	P27	GD11474	P127	GD12797-09	P10
GD1061	P28	GD11490	P75	GD12817	P39
GD1063	P28	GD11557	P139	GD12818	P106
GD10635	P83	GD11558	P139	GD12826	P39
GD10636	P83	GD11579	P93, P94	GD12827	P39
GD10638	P83	GD1162	P162	GD12829	P39
GD10646	P53	GD11649	P41	GD12847	P19
GD1065	P3	GD11652	P31, P39, P63	GD13107	P67
GD10705	P9, P19, P21, P41	GD11659	P41	GD13110	P9, P41
GD10706	P66	GD1166	P147	GD13120	P21
GD10707	P66	GD11677	P31	GD13122	P16
GD10777	P143, P145	GD11695	P75	GD13123	P16
GD10792	P87	GD11700	P45, P149	GD13124	P21
GD10793	P89	GD11705	P133	GD13125	P21
GD1085	P8	GD11721	P131	GD13126	P21
GD1086	P7	GD11751	P59	GD13127	P21
GD10867	P3, P41	GD11791	P89	GD13138	P21
GD10963	P29	GD11845	P3, P5, P17, P129	GD13143	P17
GD10984	P29	GD11950	P92	GD13144	P17
GD10991	P7	GD11951	P93, P94	GD13146	P105
GD10993	P3	GD11953	P135, P141	GD13152	P19
GD11001	P3	GD11954	P135, P141	GD13153	P69
GD11017	P5	GD11962	P3, P27, P40	GD13154	P67
GD1104	P136	GD11968	P21	GD13170	P98
GD11045	P16, P77, P131	GD11970	P99	GD13171	P98
GD11089	P119, P121, P125, P127	GD11983	P100	GD13172	P98
GD1109	P8	GD11984	P99	GD13173	P98
GD11120	P81, P83	GD11988	P91	GD13183	P21
GD1113	P4, P13, P41, P69, P87, P89, P133, P137, P139, P143, P145	GD11992	P91	GD13198	P19
GD11169	P127	GD11993	P125, P127	GD13227	P17
GD11170	P127	GD11994	P95	GD13287	P133, P139
GD11193	P93	GD11995	P95	GD13302	P95
GD11218	P40	GD12239	P93, P94	GD13303	P94, P95
GD11219	P27	GD12510	P92	GD13304	P94, P95
GD11235	P145	GD12534	P35	GD13307	P94
GD11239	P9, P27, P28	GD12543	P75	GD13309	P141
GD11240	P28	GD1255	P74, P85	GD13310	P119, P121
GD11253	P93	GD1256	P74	GD13328	P59, P147
GD11259	P3, P5	GD12597	P99	GD13329	P59
GD11263	P41	GD12657	P93, P94	GD13338	P71
GD11264	P41	GD12658	P96, P97	GD13348	P119, P121
		GD12659	P96, P97	GD13350	P71
		GD12660	P96, P97	GD13359	P89
				GD13360	P87

NUMERICAL INDEX

Part No.	Page	Part No.	Page	Part No.	Page
GD13361	P3	GD14350	P63	GD15567	P69
GD1337	P143, P145	GD14363	P63	GD15574	P69
GD13400	P98	GD14398	P31	GD15663	P25
GD13401	P75	GD14413	P77, P85	GD15689	P15
GD13412	P10	GD14414	P77, P85	GD15691	P15
GD13425	P98	GD14417	P131	GD15692	P15
GD13460	P16	GD14418	P59	GD15693	P15
GD13470	P19	GD14419	P59	GD15694	P15
GD13491	P19	GD14426	P77, P85	GD15695	P15
GD13519	P71	GD14429	P77, P85	GD15700	P25
GD13520	P71	GD14430	P77, P85	GD15725	P55
GD13524-01	P15, P16, P81	GD14431	P77, P85	GD15733	P15
GD13525	P71	GD14432	P77, P85	GD15735	P23
GD13554	P17	GD14467	P25	GD15737	P19
GD13555	P17, P23	GD14468	P25	GD15738	P19
GD13570	P16	GD14477	P25	GD15743	P17
GD13571	P21	GD14500	P17	GD15744	P21
GD13575-03	P16	GD14507	P71	GD15746	P15
GD13575-04	P16	GD14508	P94	GD15747	P9
GD13576	P21	GD14510	P93	GD15748	P19
GD13577	P21	GD14512	P81	GD15756	P23
GD13595	P19	GD14513	P81, P83	GD15757	P21
GD13628	P21	GD14517	P145	GD15766	P19
GD13648	P143	GD14520	P13	GD15789	P43
GD13652-01	P74	GD14522	P145	GD15790	P43
GD13704-01	P162	GD14528	P102	GD15792-02	P47
GD13705-02	P162	GD14541	P25	GD15792-04	P47
GD13705-03	P162	GD14547	P59	GD15792-06	P47
GD13706-01	P162	GD14562	P55	GD15792-09	P47
GD13706-03	P162	GD14592	P25	GD15792-11	P47
GD13706-04	P162	GD14626	P47	GD15792-13	P47
GD13706-05	P162	GD14627	P47	GD15792-14	P47
GD13744	P147	GD14640	P121	GD15792-16	P47
GD13766	P146	GD14659	P29	GD15792-17	P47
GD14056	P17	GD14660	P43, P121	GD15804	P43
GD14057	P17	GD14674	P33, P37	GD15806	P67
GD14058	P21	GD15100	P55	GD15807	P67
GD14059	P91	GD1512	P162	GD15812	P21
GD14066	P67	GD1520	P143	GD15849-02	P43
GD14093	P66	GD15406	P60	GD15863	P43
GD14102	P67	GD15462	P121	GD15867-01	P47
GD14115	P74	GD15465	P23	GD15867-07	P47
GD14121	P53	GD15466	P23	GD15887	P17
GD14150	P159	GD15467	P23	GD15888	P17
GD14163	P69	GD15470	P21	GD15923	P25
GD14170	P39	GD15471	P21	GD15945	P43
GD14217	P4	GD15482	P19	GD15950	P69
GD14254	P129	GD15525	P23	GD15970	P3
GD14255	P129	GD15526	P15	GD16035	P50
GD14256	P129	GD15528	P15	GD16036	P50
GD14257	P129	GD15529	P23	GD16037	P51
GD14258	P43	GD15530	P23	GD16038	P51
GD14270	P129	GD15531	P23	GD16040	P51
GD14327	P63	GD15534	P21	GD16046	P123
GD14328	P63	GD15535	P21	GD16047	P123
GD14341	P63	GD15559	P15	GD16065	P92

NUMERICAL INDEX

Part No.	Page	Part No.	Page	Part No.	Page
GD16066	P92	GD17080	P92	GD4887-09	P67
GD16067	P59	GD17099	P25	GD5154	P53, P57
GD16119-01	P49	GD17104	P25	GD5173	P52, P57
GD16119-02	P49	GD17152	P25	GD5212	P73, P76
GD16119-03	P49	GD17162	P25	GD5789	P74
GD16119-04	P49	GD17169	P41	GD5790	P74
GD16119-05	P49	GD17186	P25	GD5804	P53, P57
GD16119-11	P49	GD17187	P25	GD5841	P75
GD16120	P15	GD1719	P131	GD5857	P17, P35, P53, P73, P76, P79, P84, P127
GD16162	P23	GD17192	P9	GD5875	P66, P69
GD16163	P23	GD17212	P49	GD5892	P53, P57
GD16167	P47	GD17245	P55	GD6279-05	P45
GD16168	P149	GD17268	P43	GD6291	P119, P121, P126
GD16173	P21	GD17304	P13	GD6553	P136
GD16174	P23	GD1747	P143	GD6556	P53
GD16188	P45	GD18095	P25	GD6775	P73
GD16193	P23	GD1862	P143	GD6780	P76
GD16226	P55	GD18776	P65	GD6895	P74
GD16245	P3	GD18960	P147	GD7079	P60
GD16303	P55	GD1908	P69	GD7089	P60
GD16324-01	P43	GD2117	P10, P162	GD7127	P77
GD16397	P15	GD2161	P87	GD7137	P53
GD16399-01	P10	GD2169	P59, P71	GD7147	P99
GD16414	P67	GD2199	P73, P162	GD7148	P28
GD16415	P67	GD2423	P29	GD7209	P89
GD16460	P47	GD2557	P52	GD7251	P53
GD16461	P49	GD2558	P65, P73, P76, P85, P147	GD7258	P28
GD16462	P47	GD2589	P133	GD7318	P3
GD16463	P49	GD2597	P90	GD7426	P77, P85
GD16464	P49	GD2681	P146	GD7518	P53
GD16465	P74	GD2721	P13, P61, P87, P89	GD7519	P53
GD16468	P49	GD2725-09	P17	GD7612	P77
GD16469	P49	GD2734-13	P17	GD7639	P125, P127
GD16470	P49	GD2829	P119, P121	GD7803	P31, P39
GD16471	P49	GD2947	P29	GD7804	P31, P39
GD16472	P49	GD2971-09	P53	GD7805	P4, P8, P9, P33, P41, P53, P65, P66, P67, P71, P74, P87, P89, P141, P146, P147
GD16473	P49	GD2971-10	P27	GD7817-01	P33
GD16480	P47	GD2984	P162	GD7817-04	P33
GD16485	P10	GD3214	P87	GD7817-05	P147
GD16509	P13	GD3501	P53	GD7823	P33
GD1657	P133	GD3537-11	P57	GD7831	P147
GD16608	P51	GD3537-12	P57	GD7864	P60
GD16642	P53	GD3537-17	P57	GD7883	P57
GD16644	P51	GD3537-18	P57	GD7889	P33, P79
GD1673	P133	GD3612	P3	GD7890	P33
GD1701	P89	GD3622	P143, P145	GD7900	P136
GD17014	P3, P41	GD3623	P143, P145	GD7904-02	P67, P137
GD17021	P25	GD3860	P119, P121	GD7904-05	P19
GD17028	P25	GD3951	P143, P145	GD7907	P137
GD17047	P25	GD4086	P111, P113, P115	GD7908	P136
GD17048	P25	GD4163	P129	GD7911	P135
GD17049	P25	GD4700	P73	GD8066-02	P105
GD17050	P25	GD4701	P73		
GD17052	P41	GD4887-01	P15		
GD17078	P92	GD4887-08	P67		
GD17079	P92				

NUMERICAL INDEX

Part No.	Page	Part No.	Page	Part No.	Page
GD8188	P53, P57, P65	GR0193	P63, P71	GR1122	P151
GD8189	P52, P53, P57, P65	GR0194	P15	GR1123	P151, P155
GD8218	P135	GR0195	P147	GR1124	P153, P155
GD8224	P137	GR0196	P3, P28, P41	GR1125	P153
GD8238	P136	GR0200	P147	GR1127	P153
GD8239	P137	GR0202	P41	GR1129	P153
GD8247	P136	GR0204	P147	GR1130	P153
GD8249	P4, P67	GR0267	P147	GR1132	P153
GD8260	P53	GR0270	P75	GR1133	P153
GD8276	P137	GR0367	P63	GR1134	P153, P155
GD8306	P131	GR0375	P63, P71	GR1135	P153
GD8307	P33	GR0434	P75	GR1136	P153
GD8308	P135	GR0508	P143	GR1137	P153
GD8460	P8	GR0513	P143	GR1140	P153
GD8739	P119, P121	GR0515	P52	GR1142	P153
GD8740	P119, P121	GR0516	P52	GR1143	P153
GD8741	P119, P121	GR0517	P52	GR1144	P153
GD8751	P126	GR0528	P60	GR1145	P153
GD8770	P126	GR0531	P60	GR1146	P147, P155
GD8771	P126	GR0586	P127	GR1147	P151
GD8839	P159	GR0594	P125, P127	GR1148	P151
GD8893-01	P40	GR0761	P108	GR1165	P151
GD8893-03	P67	GR0763	P108	GR1166	P151
GD9120	P8	GR0764	P45, P108, P109	GR1167	P151
GD9129-01	P59	GR0880	P149	GR1168	P151
GD9229	P131	GR0881	P149	GR1173	P151, P153
GD9254	P31, P39	GR0882	P149	GR1203	P119, P121
GD9529	P108, P118, P120	GR0883	P149	GR1204	P119, P121
GD9530	P108, P118, P120	GR0912	P15, P16, P73, P77, P79, P85, P131	GR1205	P119, P121
GD9533	P105	GR1015	P143, P145	GR1206	P119, P121
GD9667	P81	GR1016	P143, P145	GR1207	P119, P121
GD9671	P81, P83	GR1017	P143, P145	GR1208	P119, P121
GD9672	P81, P83	GR1018	P143, P145	GR1290	P119, P121
GD9695	P41	GR1019	P143, P145	GR1292	P119, P121
GD9705	P135	GR1037	P92, P93, P94, P96, P97, P101, P102, P103, P105, P106, P111, P113, P114, P116	GR1293	P77
GD9706	P135	GR1045	P44, P45, P105, P106	GR1294	P77
GD9709	P135	GR1100	P151	GR1295	P77
GD9715	P35	GR1102	P151	GR1296	P77
GD9720	P35	GR1104	P151, P155	GR1297	P77
GD9724	P35, P37, P39	GR1105	P151	GR1301	P77
GD9896	P119	GR1106	P151	GR1303	P81, P83
GD9905	P106	GR1107	P151	GR1304	P81, P83
GD9952	P65	GR1108	P151	GR1305	P81, P83
GD9953	P53	GR1109	P151	GR1306	P81, P83
GD9959	P53, P57	GR1110	P151	GR1363	P119, P121
GD9960	P53	GR1111	P151	GR1364	P119, P121
GD9969	P73	GR1112	P151, P155	GR1390	P125
GD9977	P105	GR1114	P151	GR1391	P127
GD9981	P87, P89	GR1116	P151, P155	GR1392	P125
GM0186	P162	GR1118	P151, P155	GR1393	P127
GR0146MPP	P162	GR1119	P151	GR1397	P143
GR0150	P90	GR1120	P151, P155	GR1405	P131
GR0151	P90			GR1406	P131
GR0155MPP	P162			GR1407	P131
GR0188	P136			GR1408	P131
GR0190	P147			GR1409	P131

NUMERICAL INDEX

Part No.	Page	Part No.	Page	Part No.	Page
GR1410	P131	GR1708	P145		
GR1411	P131	GR1709	P145		
GR1412	P131	GR1734	P44		
GR1413	P131	GR1736	P43		
GR1414	P127	GR1737	P125, P127		
GR1415	P127	GR1738	P92		
GR1465	P99, P114, P116	GR1761	P127		
GR1466	P45, P51, P105, P106, P115	GR1762	P127		
GR1467	P44, P45, P50, P51	GR1764	P127		
GR1519	P99	GR1775	P92		
GR1521	P100	GR1777	P43		
GR1523	P95	GR1786	P50		
GR1524	P91	GR1796	P155		
GR1533	P157	GR1798	P155		
GR1535	P157	GR1800	P155		
GR1540	P157	GR1801	P155		
GR1541	P157	GR1803	P155		
GR1542	P157	GR1804	P155		
GR1543	P155, P157	GR1805	P155		
GR1544	P157	GR1806	P155		
GR1545	P157	GR1808	P155		
GR1550	P93	GR1828	P162		
GR1551	P96, P97	GR1834	P51		
GR1557	P77				
GR1558	P16				
GR1559	P157				
GR1561	P157				
GR1566	P157				
GR1567	P157				
GR1568	P157				
GR1570MPP	P162				
GR1572	P94				
GR1573	P95				
GR1574	P157				
GR1598	P98				
GR1601	P107				
GR1602	P107				
GR1603	P101				
GR1604	P107				
GR1605	P107				
GR1606	P107				
GR1607	P101				
GR1608	P107				
GR1609	P101				
GR1610	P107				
GR1627	P109				
GR1631	P126				
GR1632	P126				
GR1635	P105				
GR1635	P106				
GR1637	P16				
GR1678	P143				
GR1686	P145				
GR1702	P145				