

M0151

**OPERATOR & PARTS
MANUAL**

**MODEL 2500
TWIN-LINE® PLANTER**

This manual is applicable to: Model: 2500 Twin-Line® Planters
 Serial Number: 900000 and on

Record the model number and serial number of your planter with date purchased:

Model Number _____

Serial Number _____

Date Purchased _____

SERIAL NUMBER

The serial number plate is located on the planter frame to be readily available. It is suggested that the serial number and purchase date be recorded above.

The serial number provides important information about your planter and may be required to obtain the correct replacement part. Always provide the serial number and model number to your KINZE Dealer when ordering parts or anytime correspondence is made with KINZE Manufacturing, Inc.

74056-14

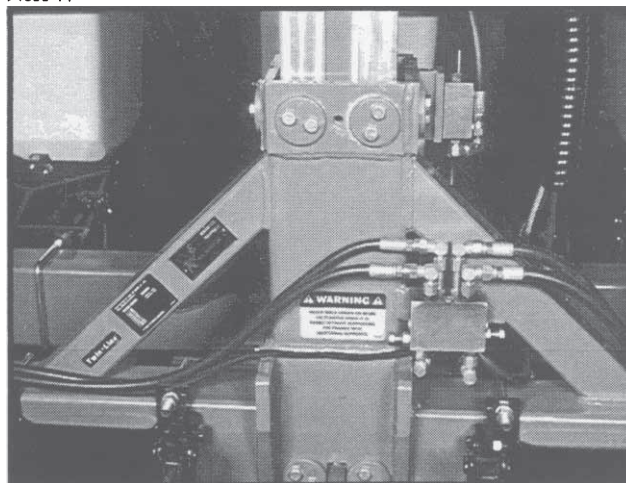

PREDELIVERY/DELIVERY CHECK LIST

TO THE DEALER

Preelivery service includes assembly, lubrication, adjustment and test. This service helps to assure that the planter will be delivered to the customer ready for field use.

PREDELIVERY CHECK LIST

After the planter has been completely assembled, use the following check list and inspect the planter. Check off each item as it is found satisfactory or after proper adjustment is made.

- Recheck to be sure row units and optional attachments are properly spaced and assembled.
- Be sure all grease fittings are in place and lubricated.
- Check planter and make sure all working parts are moving freely, bolts are tight and cotter pins are spread.
- Check all drive chains for proper tension and alignment.
- Check for oil leaks and proper hydraulic operation.
- Inflate tires to specified PSI air pressure. Tighten wheel bolts to specified torque.
- Check to be sure all safety decals are correctly located and legible. Replace if damaged.
- Check to be sure the red reflectors and amber reflectors are correctly located and visible when the planter is in transport position.
- Check to be sure SMV sign is in place.
- Check to be sure safety/warning lights are installed correctly and working properly.
- Paint all parts scratched in shipment or assembly.
- Be sure all safety lockups are on the planter and correctly located.

This planter has been thoroughly checked and to the best of my knowledge is ready for delivery to the customer.

(Signature of Set-up Person/Date)

OWNER REGISTER

Name _____

Date Sold _____

Street Address _____

Model _____

City & State _____

Serial Number _____

DELIVERY CHECK LIST

At the time the planter is delivered, the following check list is a reminder of very important information which should be conveyed to the customer. Check off each item as it is fully explained to the customer.

- Advise the customer that the life expectancy of this or any other machine is dependent on regular lubrication as directed in the operator's manual.
- Tell the customer about all the safety precautions.
- Along with the customer, check to be sure the red and amber reflectors and SMV sign are clearly visible with the planter in transport position and attached to the tractor. Check to be sure safety/warning lights are in working condition. Tell the customer to check federal, state/provincial and local regulations before towing or transporting on a road or highway.
- Give the operator's manual to the customer and explain all operating adjustments.
- Read warranty to customer.
- Complete Warranty And Delivery Report Form.

To the best of my knowledge this machine has been delivered ready for field use and customer has been fully informed as to proper care and operation.

(Signature of Delivery Person/Date)

AFTER DELIVERY CHECK LIST

The following is a list of items we suggest to check during the first season of use of the equipment.

- Check with the customer as to the performance of the planter.
- Review with the customer the importance of proper maintenance and safety precautions.
- Check for parts that may need to be adjusted or replaced.
- Check to be sure all safety decals, SMV sign and reflectors are correctly located and legible. Replace if damaged or missing.
- Check to be sure safety/warning lights are working properly.

(Signature of Follow-up Person/Date)

**RETURN THIS COMPLETED FORM TO KINZE® IMMEDIATELY, along with Warranty And Delivery Report.
Retain photocopy of this form at dealership for After Delivery Check.**

Tear Along Perforation

TABLE OF CONTENTS

TO THE OWNER	1-1
WARRANTY	1-2
INTRODUCTION	2-1
SPECIFICATIONS	3-1
SAFETY PRECAUTIONS	4-1/4-2
SAFETY WARNING SIGNS	5-1/5-4
MACHINE OPERATION	
2 To 1 Drive Reduction.....	6-3
Adjustable Wear Pads.....	6-8
Checking Granular Chemical Application Rate.....	6-24
Checking Seed Population.....	6-23/6-24
Contact Drive Wheel Spring Adjustment.....	6-3
Double Disc Fertilizer Opener.....	6-16
Dry Fertilizer Attachment.....	6-19/6-20
Electronic Seed Monitor System	
KM1000 Monitor.....	6-9/6-10
KM3000 Monitor.....	6-11/6-13
Field Test.....	6-15
General Planting Rate Information.....	6-25
Hitch Length Setting.....	6-8
Hydraulic Operation.....	6-5
Initial Preparation Of The Planter.....	6-1
Leveling The Planter.....	6-2
Liquid Fertilizer Attachment.....	6-21/6-22
Marker Adjustment.....	6-6
Marker Lockup.....	6-7
Marker Speed Adjustment.....	6-6
Metric Conversion Table.....	6-16
Planting And Application Rate Charts.....	6-26/6-34
Ridge Planting.....	6-14
Rock Guards.....	6-14
Safety Lockup Pin.....	6-7
Shear Protection.....	6-4
Single Disc Fertilizer Opener.....	6-17/6-18
Tire Pressure.....	6-2
Transmission Adjustment.....	6-3
Tractor Preparation And Hookup.....	6-1
Tractor Requirements.....	6-1
Tractor Speed.....	6-15
Transport Latch Locking Pin.....	6-7
Transporting The Planter.....	6-15
ROW UNIT OPERATION	
Brush-Type Seed Meter.....	7-3/7-4
Brush-Type Seed Meter Troubleshooting.....	7-14
Closing Wheel Lateral Adjustment.....	7-1
Closing Wheel Pressure.....	7-1
Closing Wheel Troubleshooting.....	7-14
Disc Furrowers (For use with Frame Mounted Coulter).....	7-10
Finger Pickup Corn Meter.....	7-2
Finger Pickup Corn Meter Troubleshooting.....	7-15
Frame Mounted Coulter.....	7-9/7-10
Granular Chemical Hopper.....	7-5
Granular Chemical Restrictor Plate.....	7-12
Planting Depth.....	7-1
Push Unit Lockups.....	7-5
Quick Adjustable Down Force Springs.....	7-7/7-8

TABLE OF CONTENTS

ROW UNIT OPERATION (Continued)

Row Unit Chain Routing.....	7-7
Row Unit Chain Shield.....	7-11
Row Unit Gauge Wheel Cover.....	7-13
Row Unit Mounted Disc Furrower.....	7-11
Row Unit Mounted No Till Coulter.....	7-12
Seed Hopper.....	7-5
Seed Meter Drive Adjustment.....	7-6
Seed Meter Drive Release.....	7-2
Spring Tooth Incorporator.....	7-13

LUBRICATION

Bushings.....	8-3
Center Post.....	8-1
Drive Chains.....	8-1/8-3
Grease Fittings.....	8-4/8-7
Lubrication Symbols.....	8-1
Sealed Bearings.....	8-1
Wheel Bearings.....	8-4

MAINTENANCE

15" Seed Opener Disc/Bearing Assembly.....	9-6
Brush-Type Seed Meter Maintenance.....	9-4/9-5
Chain Tension Adjustment.....	9-1
Electronic Seed Monitor System Troubleshooting.....	9-8/9-14
Finger Pickup Corn Meter Cleaning.....	9-3
Finger Pickup Corn Meter Inspection/Adjustment.....	9-2/9-3
Gauge Wheel Adjustment.....	9-6
Marker Bearing Lubrication Or Replacement.....	9-17
Mounting Bolts And Hardware.....	9-1
Piston Pump Storage.....	9-14b
Piston Pump Troubleshooting.....	9-14b
Preparation For Storage.....	9-18
Row Unit Mounted No Till Coulter.....	9-7
Seed Monitor Display Backlite Bulb Replacement (KM3000 Only).....	9-14
Seed Monitor Row Indicator Bulb Replacement (KM1000 Only).....	9-14
Seed Tube Guard.....	9-7
Torque Values Chart.....	9-1
Valve Block Assembly Inspection.....	9-15
Marker Operation Troubleshooting.....	9-16
Wear Pad Replacement/Adjustment.....	9/14a
Wheel Bearing Lubrication Or Replacement.....	9-17
Wiring Diagram.....	9-18

PARTS LIST INDEX.....	P1
-----------------------	----

PARTS SECTION NUMERICAL INDEX.....	a
------------------------------------	---

TO THE OWNER

KINZE Manufacturing, Inc. would like to thank you for your patronage. We appreciate your confidence in KINZE® farm machinery. Your KINZE® planter has been carefully designed and sturdily built to provide dependable operation in return for your investment.

This manual has been prepared to aid you in the operation and maintenance of the planter and should be considered a permanent part of the machine and should remain with the machine when you sell it.

It is the responsibility of the user to read and understand the Operator's Manual in regards to safety, operation, lubrication and maintenance before operation of this equipment. It is the user's responsibility to inspect and service the machine routinely as directed in the Operator's Manual. We have attempted to cover all areas of safety, operation, lubrication and maintenance; however, there may be times when special care must be taken to fit your conditions.

Throughout this manual the symbol  and the words, **NOTE, CAUTION, WARNING and DANGER** are used to call your attention to important safety information. The definition of each of these terms used follows:

NOTE: Indicates a special point of information.

CAUTION: Indicates that a failure to observe can cause damage to the machine or equipment.



WARNING: Indicates that a failure to observe can cause damage to the machine or equipment and/or personal injury.



DANGER: Indicates that a failure to observe can cause most serious damage to the machine or equipment and/or most serious personal injury.



WARNING: Some photos in this manual may show safety covers, shields or lockups removed for visual clarity. **NEVER OPERATE** the machine without all safety covers, shields and lockups in place.

NOTE: Some photos in this manual may have been taken of prototype machines or machines slightly different than this machine. Production machines may vary in appearance.

NOTE: Some photos and illustrations in this manual show optional attachments installed. Contact your KINZE Dealer for purchase of optional attachments.

WARRANTY

The KINZE Limited Warranty for your new machine is stated on the back of the retail purchaser's copy of the Warranty And Delivery Report form.

Warranty, within the warranty period, is provided as part of KINZE's support program for registered KINZE products which have been operated and maintained as described in this manual. Evidence of equipment abuse or modification beyond original factory specifications will void the warranty. Normal maintenance, service and repair is not covered by KINZE warranty.

To register your KINZE product for warranty, a Warranty And Delivery Report form must be completed by the KINZE Dealer and signed by the retail purchaser, with copies to the Dealer, to the retail purchaser and to KINZE. Registration must be completed and sent to KINZE within 30 days of delivery of the KINZE product to the retail purchaser. KINZE reserves the right to refuse warranty on serial numbered products which have not been properly registered.

Additional copies of the Limited Warranty can be obtained through your KINZE Dealer.

If service or replacement of failed parts which are covered by the Limited Warranty are required, it is the user's responsibility to deliver the machine along with the retail purchaser's copy of the Warranty And Delivery Report to the KINZE Dealer for service. KINZE warranty does not include cost of travel time, mileage, hauling or labor. Any prior arrangement made between the Dealer and the retail purchaser in which the Dealer agrees to absorb all or part of this expense should be considered a courtesy to the retail purchaser.

KINZE warranty does not include cost of travel time, mileage, hauling or labor.

INTRODUCTION

The Model 2500 planter is available in various configurations and row spacings. Optional interplant row spacing is obtainable with the addition of push type row units.

The Model 2500 planter permits installation of liquid or dry fertilizer application equipment and various row unit attachments.

GENERAL INFORMATION

The information used in this manual was current at the time of printing. However, due to KINZE's continual attempt to improve its product, production changes may cause your machine to appear slightly different in detail. KINZE Manufacturing, Inc. reserves the right to change specifications or design without notice and without incurring obligation to install the same on machines previously manufactured.

Right hand and left hand as used throughout this manual is determined by facing in the direction the machine will travel when in use unless otherwise stated.

69797-62

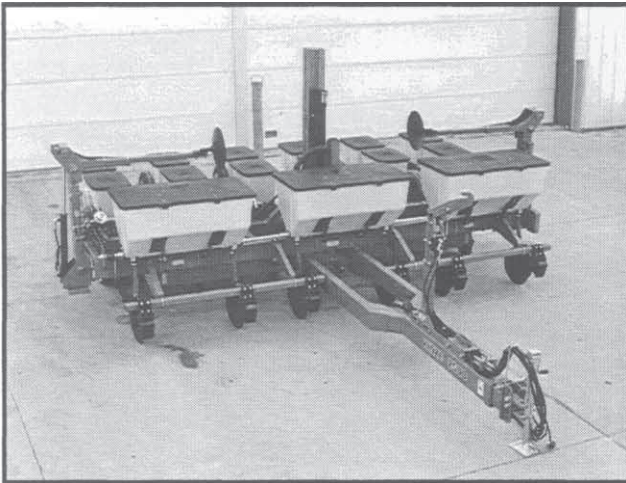

6 Row 30, Model 2500

Shown in field operation position with dry fertilizer option and double disc fertilizer openers installed.

67999-2

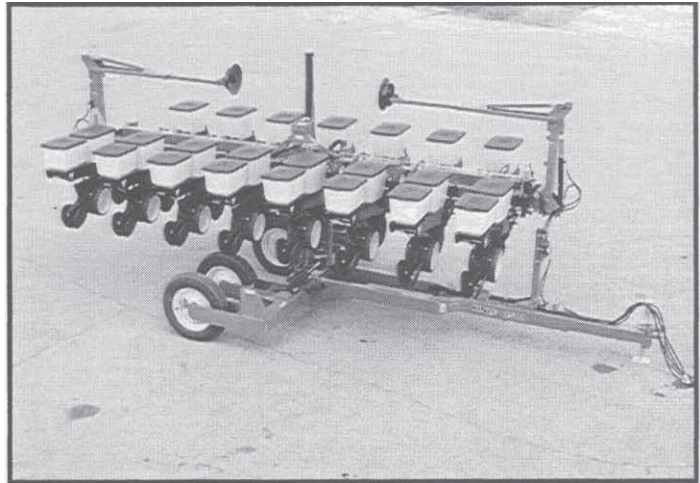

8 Row 30, Model 2500

Shown in transport position with solid interplant option installed.

SPECIFICATIONS

TYPE Pull-type, rigid frame. Rotating main frame for transport, hydraulic operation.

PLANTING UNIT TYPES Pull-Type Row Units; Push-type Row Units Optional

ROW SPACING	<u>Standard</u>	<u>Interplant</u>
	6 Row Narrow - 30" Rows	11 - 15" Rows (9 - 15" Skip Rows)
	8 Row Narrow - 30" Rows	15 - 15" Rows (13 - 15" Skip Rows)

DRIVE SYSTEM

Two 4.10" x 6" rib implement 6 ply spring-loaded contact drive tires. (Driven by two 7.50" x 20" transport tires.)
 No. 40 chain with spring-loaded idlers.
 Quick-adjust end-mounted seed transmission with machined sprockets.
 7/8" hex drive and drill shafts.

TRANSPORT TIRES

Four 7.50" x 20" rib implement 6 ply tires.
 Adjustable height wheels for ridge planting.

LIFT One centrally located lift cylinder. (Front or rear mount.)

MARKERS Two-fold low profile with 16" concave blade and cast iron hubs.

HYDRAULICS Dual SCV for independent operation of lift and markers.
 Manual hand valve selects marker/rotate functions.
 Hydraulic alternating sequence valve with flow controls for markers.

Dimensions

PLANTER SIZE	6 Row 30"	8 Row 30"
Operating Width	16' 10"	21' 10"
Operating Length	19' 2"	20' 5"
Transport Width	11' 2"	11' 2"
Transport Height	10' 6"	10' 6"
Transport Length	21' 8"	25' 4"
Weight	5182 lbs.	5876 lbs.

* Base machine weights include planter frame including row markers, drive components, tires and wheels, hydraulic cylinders and KINZE plateless row units with seed hopper and lid and dual quick adjustable down force springs.

SAFETY PRECAUTIONS

Safe and careful operation of the tractor and planter at all times will contribute significantly to the prevention of accidents.

Since a large portion of farm accidents occur as a result of fatigue or carelessness, safety practices should be of utmost concern. Read and understand the instructions provided in this manual. Listed below are a few other safety suggestions that should become common practice.

 Never allow the planter to be operated by anyone who is unfamiliar with the operation of all functions of the unit. All operators should read and thoroughly understand the instructions given in this manual prior to moving the unit.

 Never permit any persons other than the operator to ride on the tractor.

 Never ride on the planter or allow others to do so.

 Always make sure there are no persons near the planter when marker assemblies are in operation.

67976-14

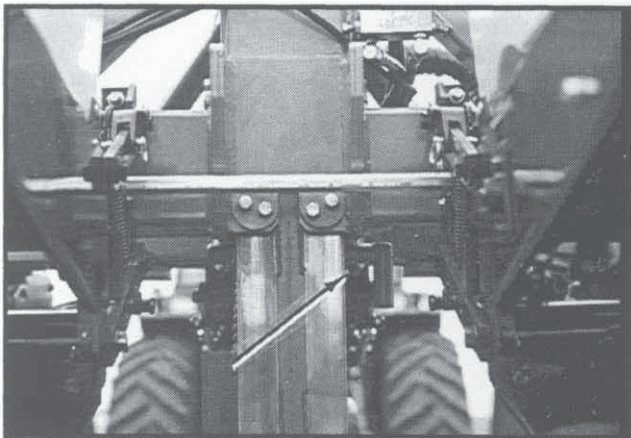

Safety Lockup

 Always install safety lockup before transporting the planter.

 Never work under the planter while in raised position without installing manual safety lockup.

 Before operating the planter for the first time and periodically thereafter, check to be sure the lug nuts on the transport wheels are tight. This is especially important if the planter is to be transported for a long distance.

 Watch for obstructions such as wires, tree limbs, etc., when folding markers.

69797-83

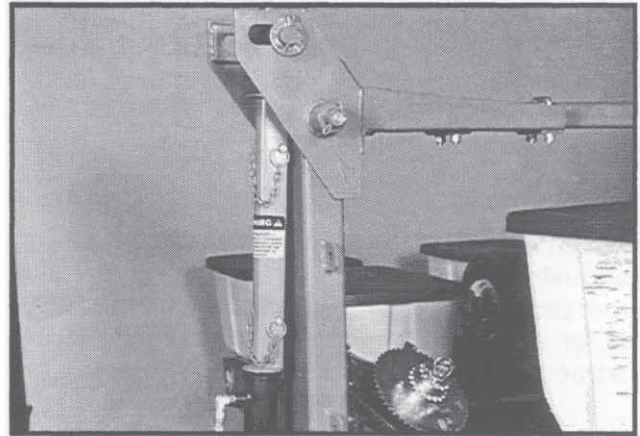



Marker Lockup Bracket

 Install lockup brackets on markers prior to transporting the planter or working around the unit.

 Limit towing speed to 15 MPH. Tow only with farm tractor of at least 70 HP size.

 Always make sure flashing safety lights, reflectors and SMV emblem are in place and visible prior to transporting the machine on public roads. In this regard, check federal, state/provincial and local regulations.

 Check to be sure all safety/warning lights are working before transporting the machine on public roads.

 This planter is designed to be DRIVEN BY GROUND TIRES ONLY. The use of hydraulic, electric or PTO drives may create serious safety hazards to you and the people near by. If you install such drives you must follow all appropriate safety standards and practices to protect you and others near this planter from injury.

SAFETY PRECAUTIONS

 This machine has been designed and built with your safety in mind. Any alteration to the design or construction may create safety hazards. Do not make any alterations or changes to the equipment, but if any alterations or changes are made you must follow all appropriate safety standards and practices to protect you and others near this machine from injury.

 Rim and tire servicing can be dangerous. Explosive separation of a tire and rim parts can cause serious injury or death.

 Agricultural chemicals used with this unit can be dangerous. Improper selection or use can seriously injure persons, animals, plants, soil and other property. **BE SAFE:** Select the right chemical for the job. Handle it with care. Follow the instructions of the chemical manufacturer.

SAFETY WARNING SIGNS

The "WARNING" signs illustrated on this page are placed on the machine to warn of hazards. The warnings found on these signs are for your personal safety and those around you. **OBSERVE THESE WARNINGS!**

- Keep these signs clean so they can be readily observed. Wash with soap and water or cleaning solution as required.
- Replace "WARNING" signs should they become damaged, painted over or if they are missing.
- Check the SMV decal periodically. Replace if it shows loss of any of its reflective property.
- When replacing decals, clean the machine surface thoroughly using soap and water or cleaning solution to remove all dirt and grease.

69797-55

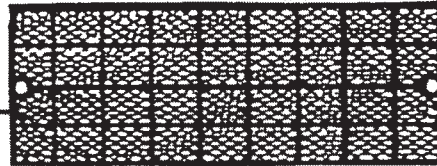
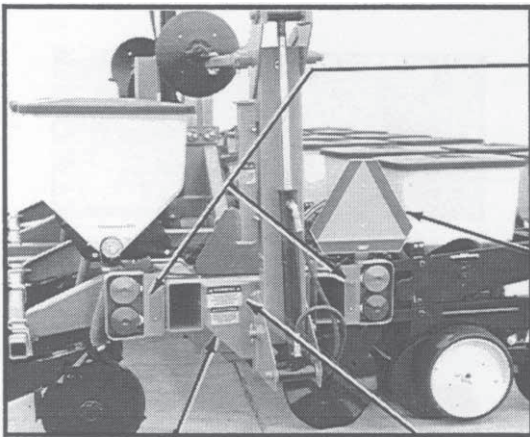

Part No. 7200-03 Red Reflector (Qty. 2)



Part No. D2199 SMV Emblem (Qty. 1)

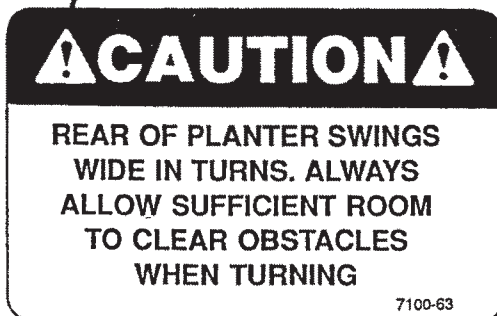

Part No. 7100-63 (Qty. 2)
1 on each end of planter frame.

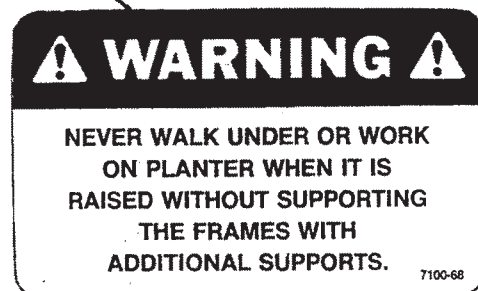

Part No. 7100-68 (Qty. 2)
1 on each end of planter frame.

SAFETY WARNING SIGNS

66337-2

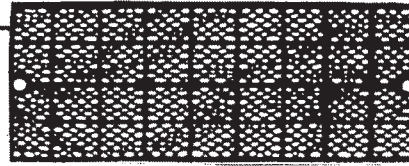
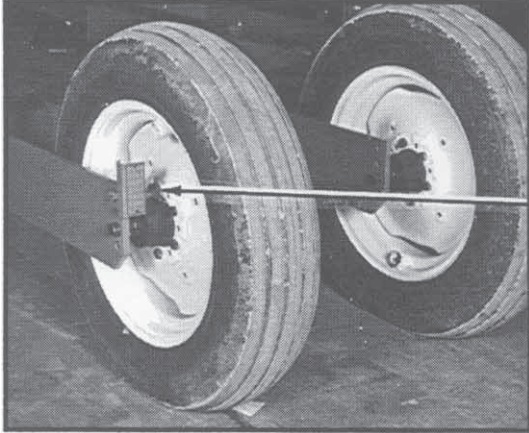

Part No. 7200-03 Red Reflector (Qty. 2)

66337-20

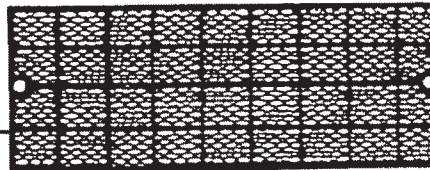
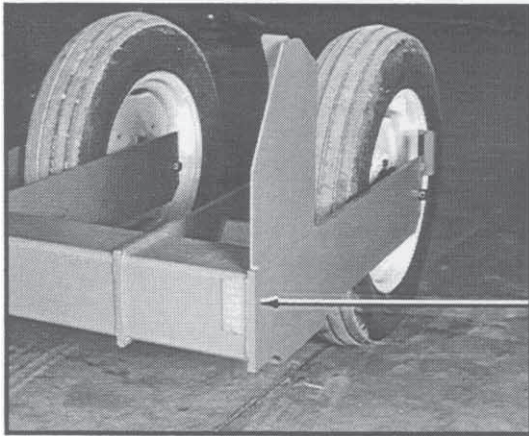

Part No. 7200-02 Amber Reflector (Qty. 2)

69797-2

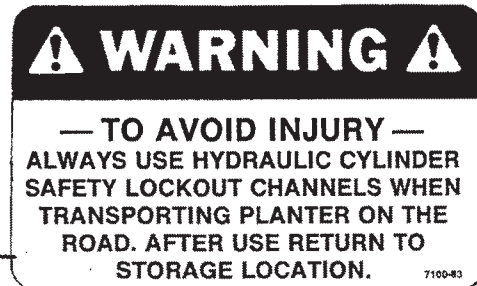
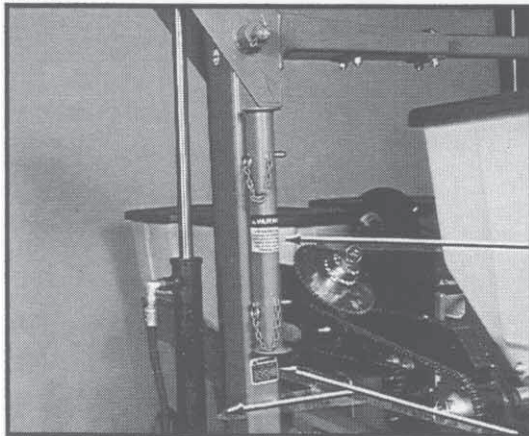

Part No. 7100-83 (1 per marker lockup)



Part No. 7100-42 (2 per marker assembly))

SAFETY WARNING SIGNS

69797-58

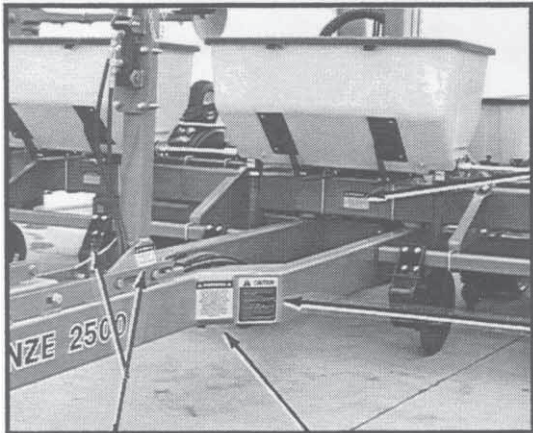

Part No. 7100-68 (Qty. 1)

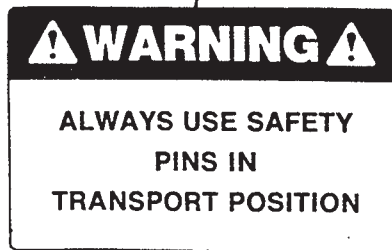

Part No. 7100-02 (Qty. 2)



Part No. 7100-90 (Qty. 1)

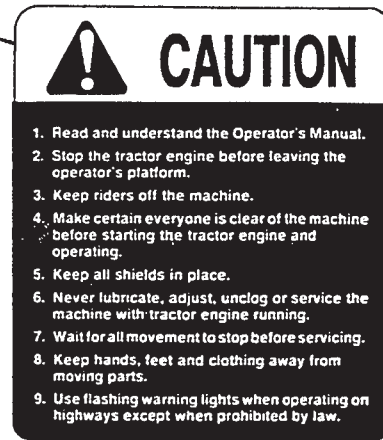

Part No. 7100-46 (Qty. 1)

69807-5

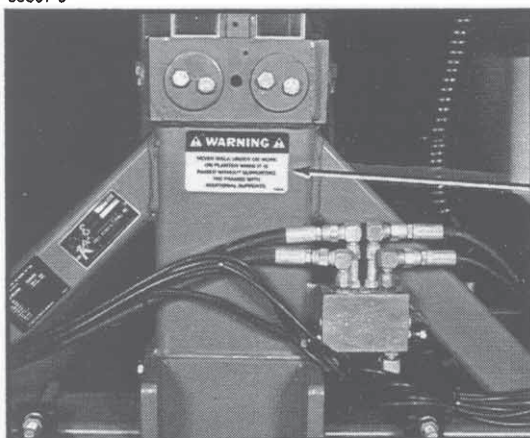

Part No. 7100-68 (Qty. 1)

67999-48

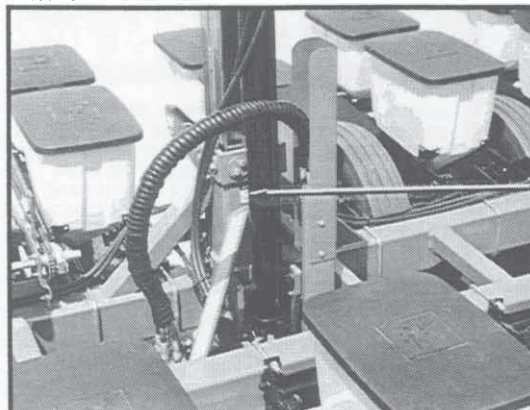

Part No. 7100-02 (Qty. 1)

SAFETY WARNING SIGNS

69797-44

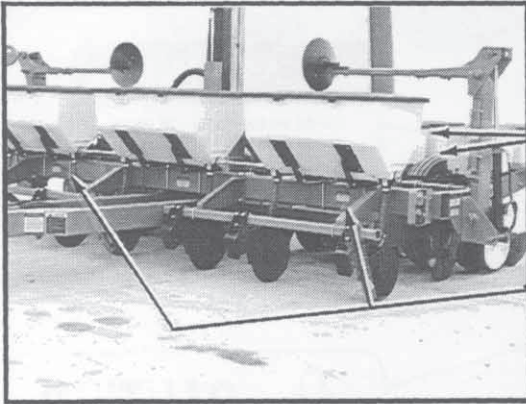

CAUTION

AVOID UNEVEN LOADING
OF HOPPERS, ESPECIALLY
DURING TRANSPORT

7100-75

Part No. 7100-75 (Qty. 4)
2 on front of front planter frame and
2 on back of rear planter frame.

69797-63

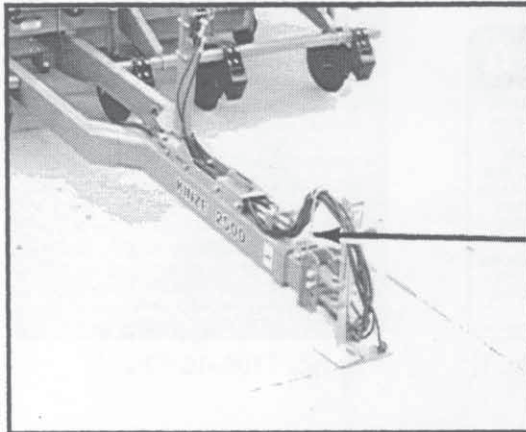

WARNING

TOW ONLY WITH
FARM TRACTOR.

Part No. 7100-56 (Qty. 1)

69797-49

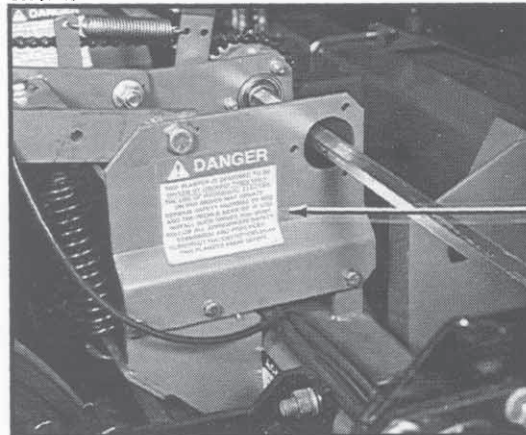

DANGER

THIS PLANTER IS DESIGNED TO BE
DRIVEN BY GROUND TIRES ONLY.
THE USE OF HYDRAULIC, ELECTRIC
OR PTO DRIVES MAY CREATE
SERIOUS SAFETY HAZARDS TO YOU
AND THE PEOPLE NEAR BY. IF YOU
INSTALL SUCH DRIVES YOU MUST
FOLLOW ALL APPROPRIATE SAFETY
STANDARDS AND PRACTICES
TO PROTECT YOU AND OTHERS NEAR
THIS PLANTER FROM INJURY.

7100-89

Part No. 7100-89 (Qty. 2)

59386-15

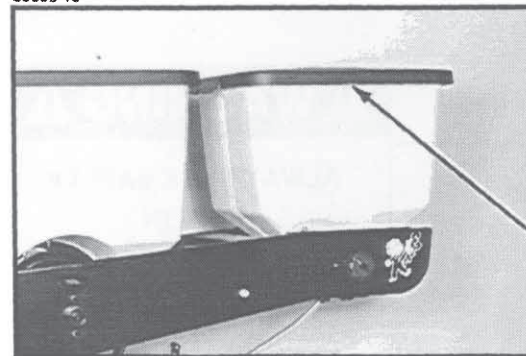

CAUTION

AGRICULTURAL CHEMICALS CAN BE DANGEROUS.
IMPROPER SELECTION OR USE CAN SERIOUSLY
INJURE PERSONS, ANIMALS, PLANTS, SOIL OR
OTHER PROPERTY. **BE SAFE:** SELECT THE RIGHT
CHEMICAL FOR THE JOB. HANDLE IT WITH CARE.
FOLLOW THE INSTRUCTIONS ON THE CONTAINER
LABEL AND OF THE EQUIPMENT MANUFACTURER.

7100-115

Part No. 7100-115
Located on under side of granular chemical
hopper lid.

MACHINE OPERATION

The following information is general in nature and was written to aid the operator in preparation of the tractor and planter for use, and to provide general operating procedures. The operator's experience, familiarity with the machine and the following information should combine for efficient planter operation and good working habits.

INITIAL PREPARATION OF THE PLANTER

Lubricate the planter and row units per the lubrication information in this manual. Make sure all tires have been properly inflated. Check all drive chains for proper tension, alignment and lubrication.

TRACTOR REQUIREMENTS

Consult your dealer for information on horsepower requirements and tractor compatibility. Requirements will vary with planter options, tillage and terrain. Two dual remote hydraulic outlets (SCV) are required on all models. 12 volt DC electrical system is required on all models to operate planter safety/warning lights.

TRACTOR PREPARATION AND HOOKUP

67999-18

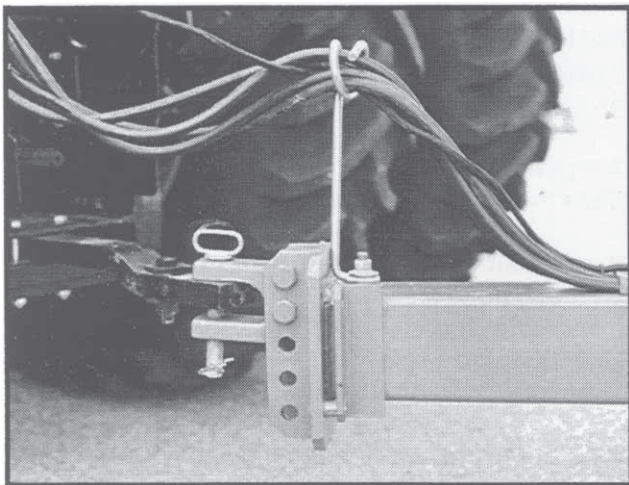

1. Adjust tractor drawbar to 13-17 inches above the ground. Adjust the drawbar so the hitch pin hole is directly below the center line of the PTO shaft. Make sure the drawbar is in a stationary position.

2. Back tractor to planter and connect with hitch pin. Make sure hitch pin is secured with locking pin or cotter pin.

3. Connect hydraulic hoses to tractor ports in a sequence which is both familiar and comfortable to the operator.

! **DANGER:** Before applying pressure to the hydraulic system, make sure all connections are tight and hoses and fittings have not been damaged. Hydraulic fluid escaping under pressure can have sufficient force to penetrate skin, causing injury or infection.

CAUTION: Always wipe hose ends to remove any dirt before connecting couplers to tractor ports.

4. Connect ASAE Standards 7-pin connector for warnings lights on planter to ASAE Standards receptacle on tractor. If your tractor is not equipped with an ASAE Standards receptacle, check with your tractor manufacturer for availability. Check to be sure warning lights on planter are working in conjunction with warning lights on tractor.

5. Raise jack stand and remount horizontally on storage bracket.

6. Lower planter to the planting position and check to be sure the hitch is level. If hitch slopes up or down, disconnect planter and adjust hitch clevis up or down as necessary.

MACHINE OPERATION

LEVELING THE PLANTER

For proper operation of the planter and row units, it is important that the unit operate level.

67999-26

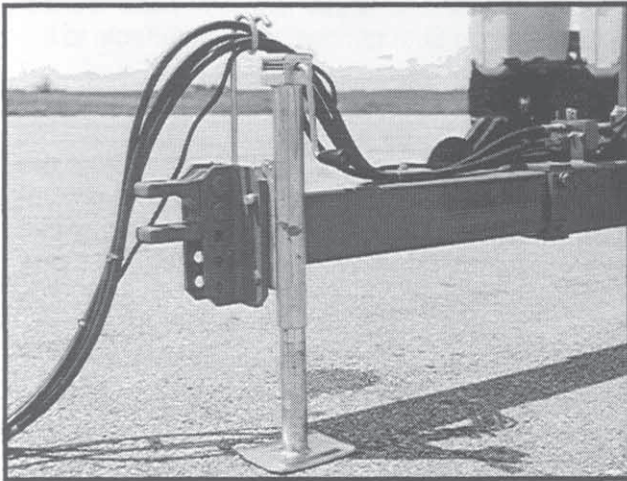

Five holes in the hitch bracket allow the clevis to be raised or lowered. In addition, the clevis may be turned over for a finer adjustment between mounting holes. When installing clevis mounting bolts, make sure lock nuts are tightened to proper torque setting.

69797-86

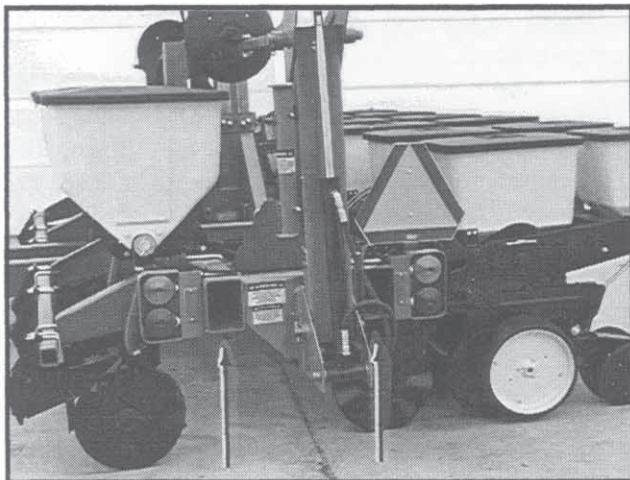

With the planter lowered to proper operating depth, check to be sure the frame is level fore and aft. Recheck once planter is in the field.

It is important for the planter to operate level laterally. Tire pressure must be maintained at pressures specified. See "Tire Pressure".

TIRE PRESSURE

66337-10

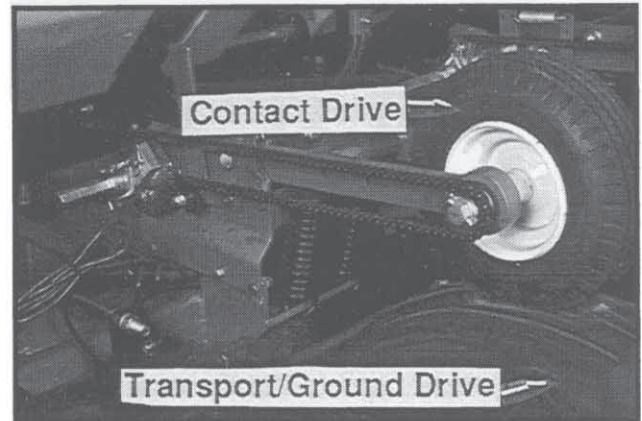

Tire pressure should be checked regularly and maintained as follows:

Transport/Ground Drive 7.50" x 20"	40 PSI
Contact Drive 4.10" x 6"	60 PSI

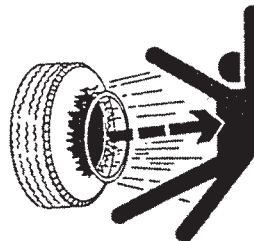

DANGER: Rim and tire servicing can be dangerous. Explosive separation of a tire and rim parts can cause serious injury or death.

Do not attempt to mount a tire unless you have the proper equipment and experience to perform the job. This should only be done by persons properly trained and equipped to do the job.

Always maintain the correct tire pressure. Do not inflate the tires above the recommended pressure.

When inflating tires, use a clip-on air chuck and extension hose long enough to allow you to stand to one side and NOT in front of or over the tire assembly. Use a safety cage to enclose the tire and rim assembly when inflating.

Inspect tires and wheels daily. Do not operate with low pressure, cuts, bubbles, damaged rims or missing lug bolts and nuts

MACHINE OPERATION

TRANSMISSION ADJUSTMENT

Planting population rate changes are made at the end of the planter. The planter is designed to allow simple, rapid changes in sprockets to obtain the desired planting population. By removing the lynch pins on the hexagon shafts, sprockets can be interchanged with those from the sprocket storage rod bolted to the transmission.

Chain tension is controlled by a spring-loaded dual-sprocket idler. The idler assembly is adjusted with a ratchet arm. This arm has a release position to remove spring tension for replacing sprockets. The amount of spring tension on the chain can be controlled by the ratchet arm.

The planting rate charts found at the back of this section will aid you in selecting the correct sprocket combinations.

69797-7

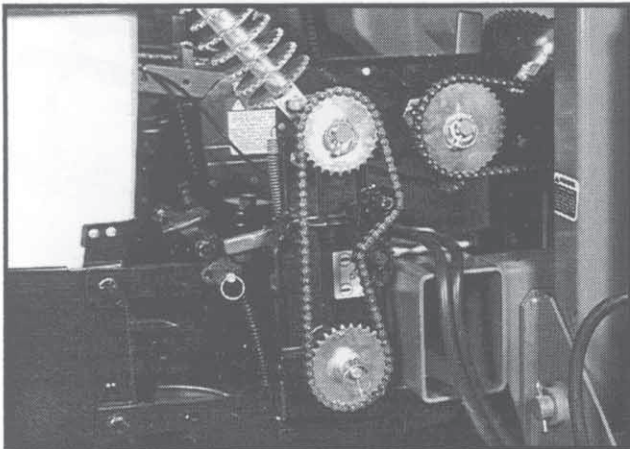

2 TO 1 DRIVE REDUCTION

69797-16

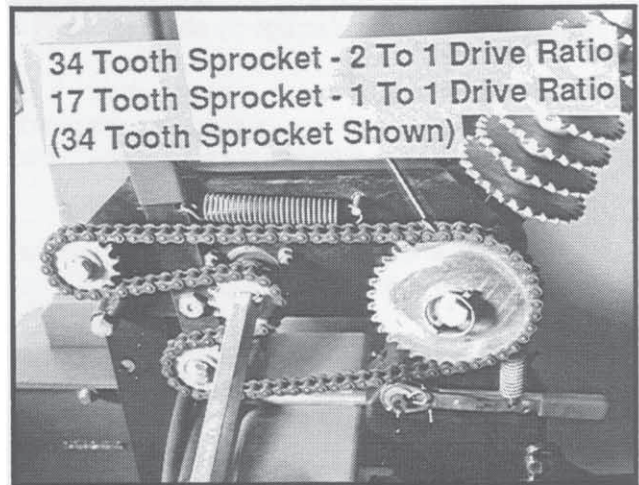

Replacing the 17 tooth drive sprocket located on the inner side of the top transmission shaft, with the 34 tooth 2 to 1 drive reduction sprocket will reduce the planter transmission speed and reduce planting rates by approximately 1/2.

IMPORTANT: After each sprocket combination adjustment, make a field test to be sure you are planting at the desired rate.

CONTACT DRIVE WHEEL SPRING ADJUSTMENT

66337-11

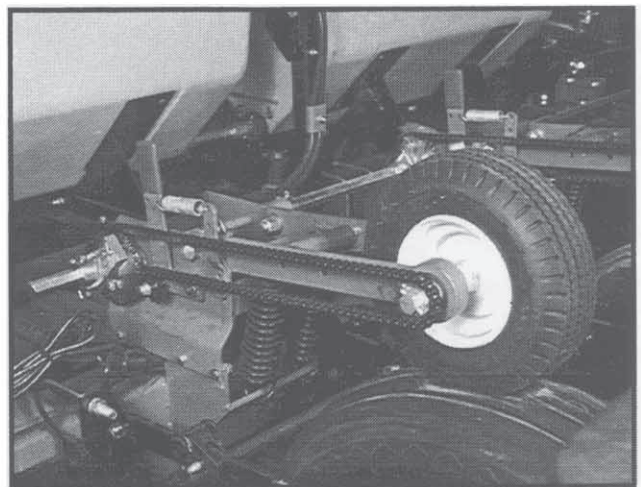

There are two down pressure springs on each contact drive wheel. The down pressure is factory preset and should need no further adjustment.

Tightening bolts are set to end of threads.

MACHINE OPERATION

SHEAR PROTECTION

The planter drive line, row unit and fertilizer components are protected from damage by shear pins.

If excessive load should cause a pin to shear, it is important to determine where binding has occurred before replacing the pin. Replace shear pins with same size and type.

Additional shear pins can be found in the storage area located in the end of the front toolbar.

To prevent future binding or breakage of components, check drive line alignment and follow prescribed lubrication schedules.

69797-9

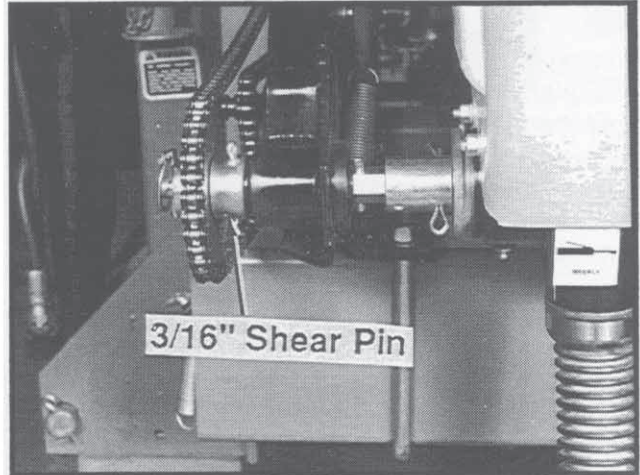

Dry Fertilizer Attachment Transmission

61658-27

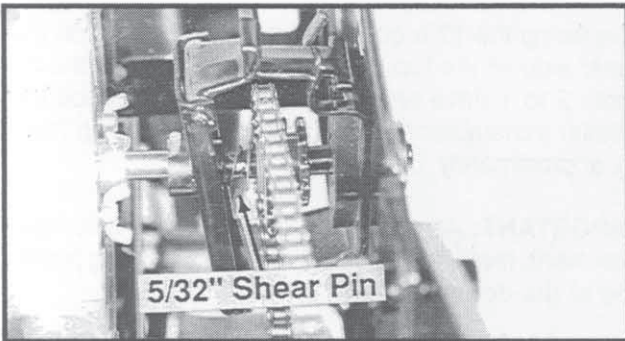

Row Unit Seed Meter Drive

55702-10

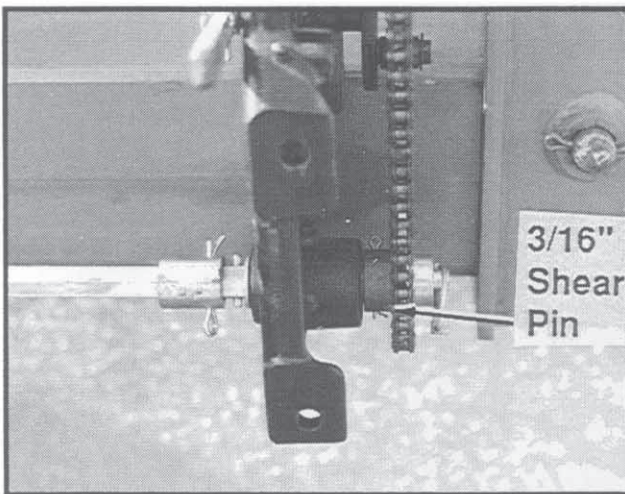

Transmission Shaft

69922-6

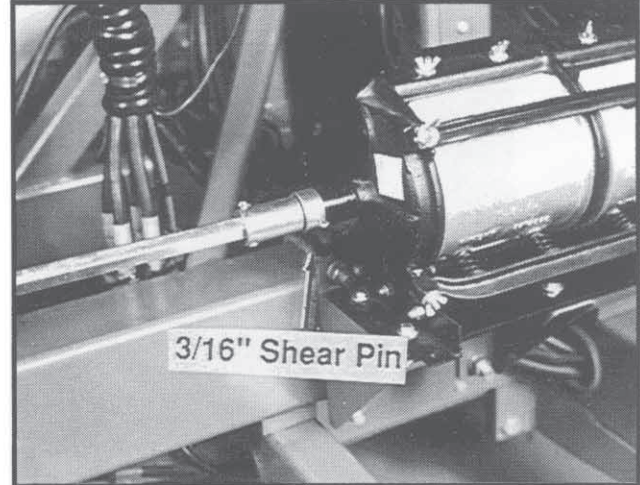

Liquid Fertilizer Squeeze Pump Drive

MACHINE OPERATION

HYDRAULIC OPERATION

All 2500 Planters are equipped for operation from two dual remote hydraulic outlets (SCV).

One set of outlets is used to raise and lower the planter and one set is used to operate the markers and fold functions. A hand operated selector valve on the hitch allows selection of marker or fold functions.

NOTE: Release hydraulic pressure from the system before moving the selector handle.

69797-67

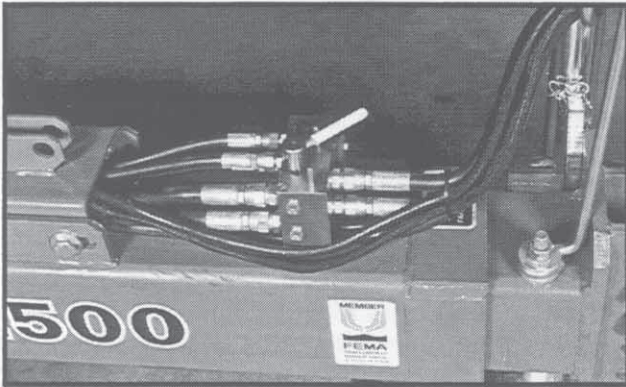

PLANTER LIFT SYSTEM OPERATION

The planter lift system consists of one lift cylinder located at the center of the machine. Mounts for this cylinder are located ahead and behind the rotation post. For planters with rear mounted row units only, the cylinder must be installed in the rear position. For planters with front mounted options (push units, fertilizer, etc.), the cylinder must be installed in the front position.

NOTE: The planter lift cylinder is equipped with a counter balance valve. Hydraulic pressure is required to lower the planter.

69797-74

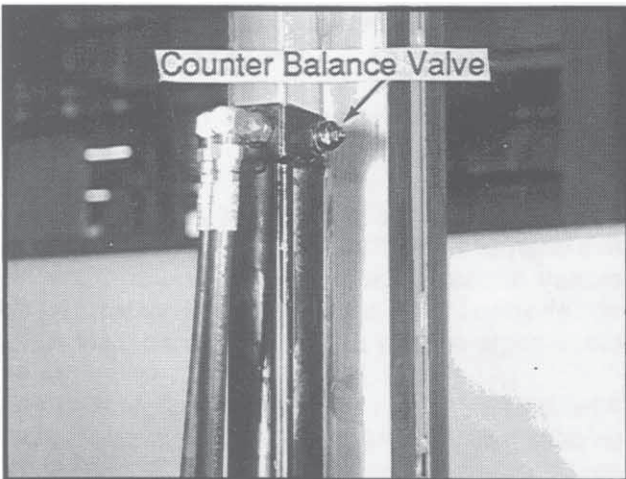

Raised Field Position

74056-2

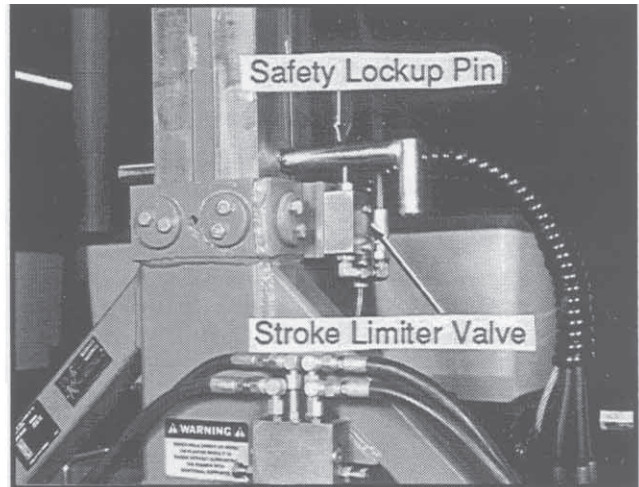

There are two raised positions on the planter. The first position is with the safety lockup pin installed above the frame assembly to make contact with the stroke limiter valve. This will allow the row units to raise approximately 14 inches off the ground and the toolbar approximately 40 inches. This position is used in making turns or passing over waterways during field operation.

Raised Transport Position

74056-7

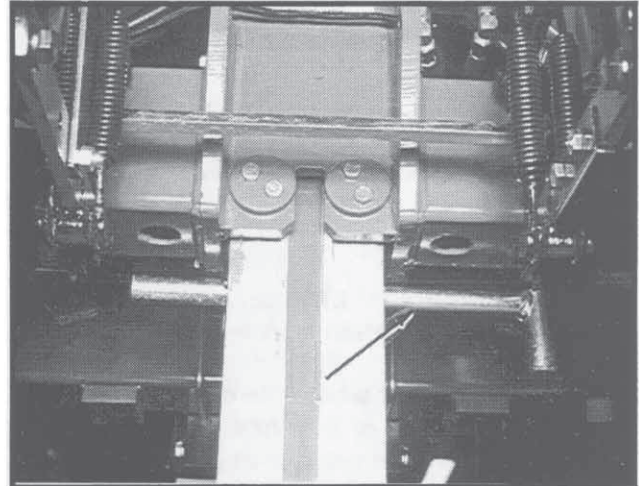

The second raised position is the raised transport position. In this position the planter is allowed to raise high enough to permit the row units to clear the transport wheels for the planter to rotate. To raise the planter to the raised transport position: (1) Remove the safety lockup pin. (2) Raise the planter until the lift cylinder is fully extended. (3) Reinstall the safety lockup pin in the same hole which is now below the frame structure.

⚠ DANGER: Never work under the planter while in raised position without installing safety lockups.

MACHINE OPERATION

MARKER SPEED ADJUSTMENT

The marker hydraulic system is equipped with two flow control valves. One flow control valve controls the lowering speed of both markers and one controls the raising speed of both markers. To adjust marker speed, loosen the jam nut and turn the control clockwise or IN to slow the travel speed and counterclockwise or OUT to increase the travel speed. The flow control determines the amount of oil flow restriction through the valve, therefore determining travel speed of the markers.

74056-9

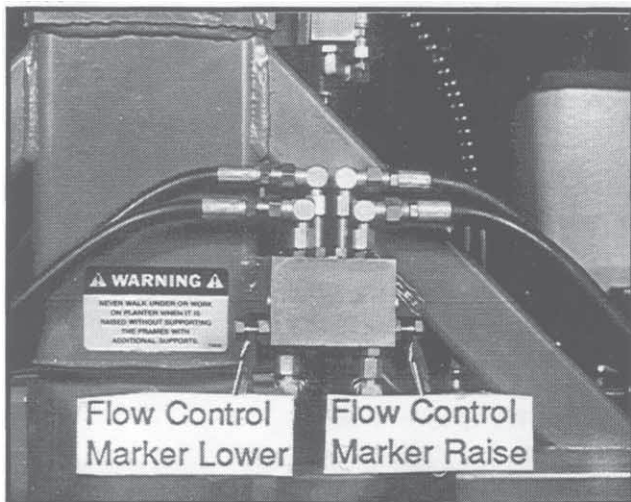

⚠ DANGER: The flow controls should be properly adjusted before the marker assembly is first put into use. Excessive travel speed of the markers can be dangerous and/or damage the marker assembly.

NOTE: When oil is cold, hydraulics operate slowly. Make sure all adjustments are made with warm oil.

NOTE: On a tractor where the oil flow can not be controlled, the rate of flow of oil from the tractor may be greater than the rate at which the marker cylinder can accept it. The tractor hydraulic control lever will have to be held until the cylinder reaches the end of its stroke. This occurs most often on tractors with an open center hydraulic system.

On tractors with a closed center hydraulic system, the tractor's hydraulic flow control should be adjusted to the full flow position. If oil is restricted, the sequencing valve may not shift properly.



MARKER ADJUSTMENT

To determine the correct length at which to set the marker assemblies, multiply the number of rows by the average row spacing in inches. This provides the total planting width. Adjust the marker extension so the distance from the marker blade to the center line of the planter is equal to the total planting width previously obtained. Both the planter and marker assembly should be lowered to the ground when measurements are being taken. The measurement should be taken from the point where the blade contacts the ground. Adjust right and left marker assemblies equally and securely tighten clamping bolts. An example of marker length adjustment follows:

Number of rows	X	Row spacing (Inches)	=	Dimension between planter center line and marker blade.
----------------	---	----------------------	---	---

8 Rows X 30" Spacing = 240" Marker Dimension

NOTE: To allow correct marker adjustment, 6 row 30" machines setup with 15" row spacing require the use of shorter marker extensions which are supplied in the interplant package

55712-6

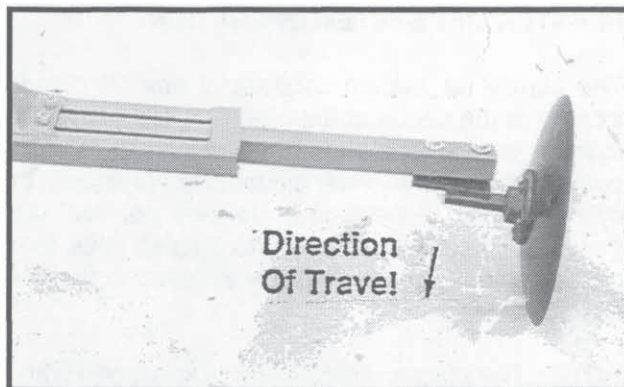

The marker blade is installed so the concave side of the blade is outward to throw dirt away from the grease seals. The spindle bracket is slotted so the hub and blade can be angled to throw more or less dirt. To adjust the hub and spindle, loosen the 1/2" x 3 1/2" cap screws and move the bracket as required. Tighten bolts to the specified torque.

IMPORTANT: A marker blade assembly that is set at a sharper angle than necessary will add unnecessary stress to the complete marker assembly and shorten the life of bearings and blades. Set the blade angle only as needed to leave a clear mark.

A field test is recommended to ensure the markers are properly adjusted. After the field test is made, make any minor adjustments necessary.

MACHINE OPERATION

MARKER LOCKUP

Install marker lockups over marker cylinder rods when transporting the planter or working around the planter. When not in use, store in the storage position provided as shown below.

 **DANGER:** To avoid serious injury, keep others away when raising or lowering markers.

69797-2

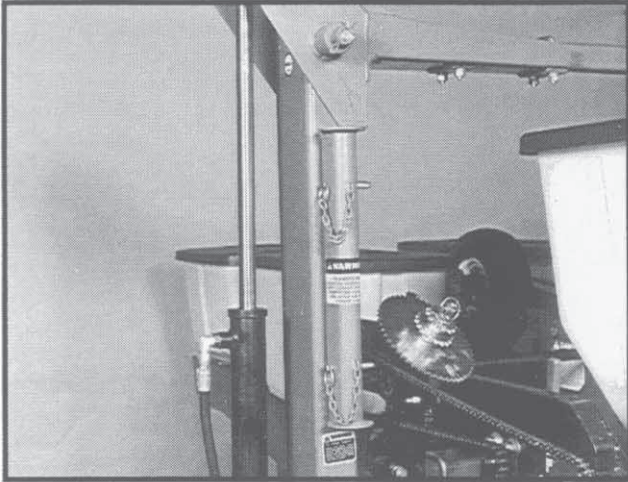

Lockup stored for marker operation.

69797-83

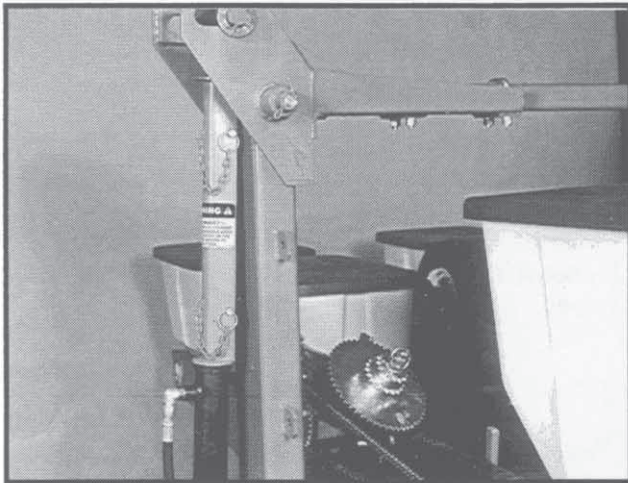

Marker locked up for transport or working around the machine.

TRANSPORT LATCH LOCKING PIN

When the planter is rotated to the transport position, the transport latch located on the hitch of the planter locks in place under the marker mount.

Prior to transporting the planter, install the transport latch locking pin to lock the latch.

66337-27

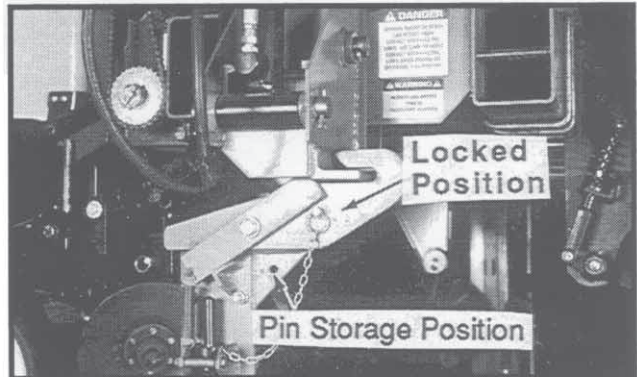

Pin in locking position to secure planter during transport.

SAFETY LOCKUP PIN

The safety lockup pin located on the center frame structure is an added safety device. Never allow anyone to work around or under the planter without first installing the manual safety lockup in place. When transporting the planter use the safety lockup for added safety.

74056-7

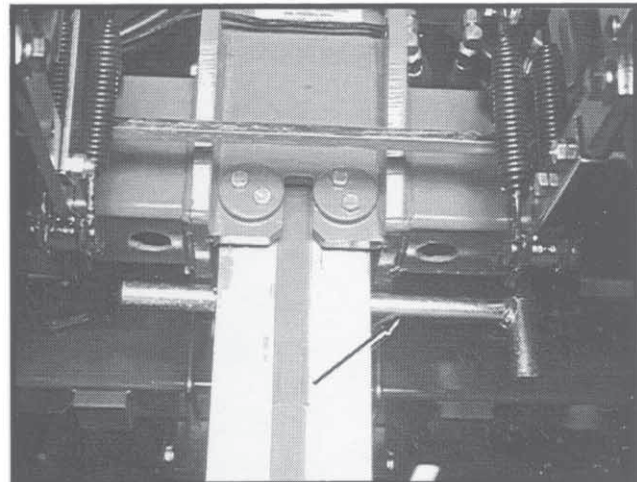

NOTE: The center post is clad with stainless steel. To prolong service life keep stainless steel surface clean and free of any lubrication.

CENTER POST AND POLY WEAR PADS REQUIRE NO LUBRICATION. ANY OIL OR GREASE WILL ATTRACT DIRT AND ACCELERATE WEAR ON THE CENTER POST AND ON THE POLY WEAR PADS.

MACHINE OPERATION

ADJUSTABLE WEAR PADS

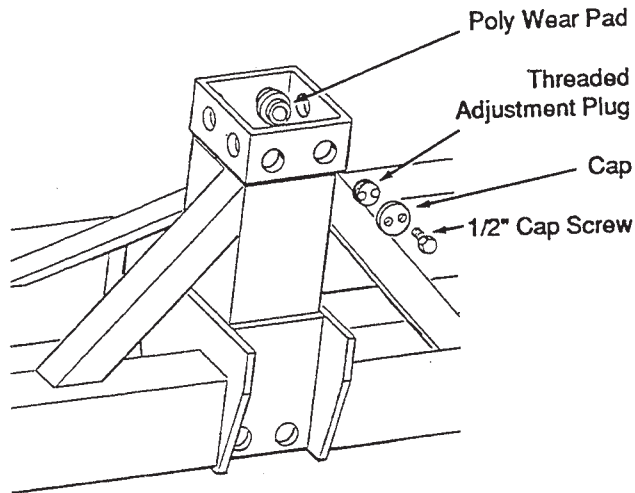

The center section of the planter consists of a steel tubular frame equipped with 16 adjustable wear pad assemblies which travel up and down over a stainless steel clad center post. Each adjustable wear pad assembly consists of a poly wear pad, a threaded adjustment plug and a cap. The assembly is held in place by the threaded adjustment plug and locked in place by the cap and two 1/2" hex head cap screws.

Check pad adjustment and wear annually. See "Wear Pad Replacement/Adjustment" for additional information.

HITCH LENGTH SETTING

The hitch length can be adjusted in 15" increments to match the tractor being used and options installed on the planter.

AB4392

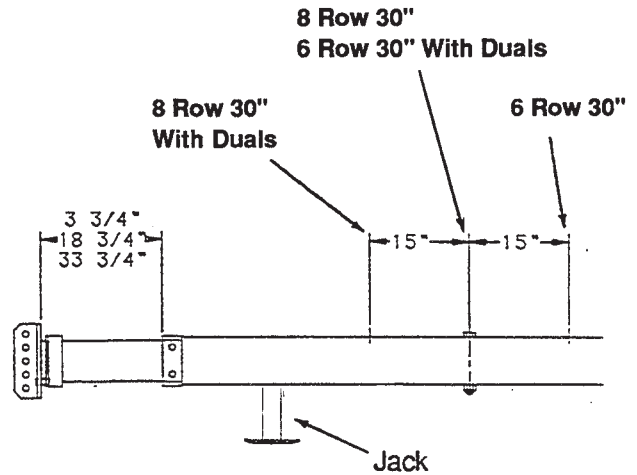

The hitch consists of a rear section of 7" square tube and a front section of 6" square tube. To adjust the length, lower the machine to the field position and block the transport wheels. Support the 7" square tube with a minimum 5000 pound rated jack to take the weight off the 6" square tube. Remove the 1 1/4" x 9" hex head cap screw, loosen the two 5/8" hex head cap screws on the front end of the 7" square section and reposition the 6" square section to the desired length.

CAUTION: DO NOT set the hitch so short that turning ability is limited when the machine is in road transport position.

Reinstall and tighten hardware to specified torque values.

MACHINE OPERATION

ELECTRONIC SEED MONITOR SYSTEM

The electronic seed monitor system consists of a console, which is mounted on the tractor; seed tubes with sensors, one of which is installed in each planter row unit; and a planter harness (harness, Y-connector and/or extension cable where applicable), which connects the individual seed tube sensors to the console.

The monitor is powered by the tractor battery (requires 12 volts DC).

KM1000 MONITOR

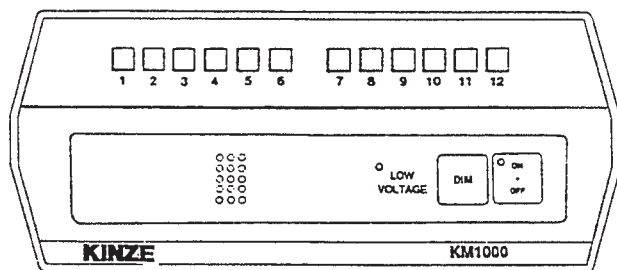

The console receives information from each of the sensors and translates this information for the operator, to let him know whether or not all rows are planting.

Turn the console ON by pressing the ON-OFF switch.

Each time the console is powered up it performs a sensor check and self-check. All row indicator lamps are turned on, the alarm sounds momentarily and then the console enters the operate mode. If a row indicator lamp does not come on when the console is powered up, it indicates that a problem exists with either the sensor, planter harness or a burned out row indicator lamp. See Troubleshooting in the Maintenance Section of this manual.

Begin planting and observe the row indicator lamps. All indicator lamps should be flashing at approximately the same rate. If one of the row lamps is flashing at a slower rate than the others it would indicate that row is planting at a slower rate and it should be checked for proper seed population.

The monitor continuously checks for seed flow while planting, as indicated by the flashing row indicator lamps on the console. If any planter unit seed sensor is not detecting seeds, the alarm will sound continuously and the row indicator lamp corresponding to the planter row unit will stop flashing. When this happens, stop planting and check to see what is wrong with the row unit.

When you lift your planter at the end of a row and seed flow stops in all planter units, the alarm will sound and all row indicator lamps will stop flashing. After approximately 2-4 seconds the alarm will stop sounding.

The intensity of the Row Indicator Lamps can be controlled by pressing and holding the switch labeled DIM. To set the intensity, press and hold the DIM switch until the lamps are at the desired intensity, release the switch. Holding the DIM switch will cause the intensity to decrease to its lowest level and then increase to its maximum level. This cycle will continue as long as the switch is depressed. When the console is turned OFF and then ON the row lamp intensity will return to maximum.

If you are only using a portion of the number of rows on your planter, the alarm can be silenced by disconnecting the seed sensors of the unused rows and turning the monitor OFF then back ON. The monitor will then ignore these unused rows and monitor the other rows normally.

When disabling planter rows, the monitor may look at the system as a different planter setup. Example, if you have an 8 row planter and you disable the right four rows (for planting point rows, etc.) by unplugging the seed sensors and turning the monitor OFF and back to ON, the monitor will look at it as a 4 row planter and shift the row indicator lamps to the center four positions. Therefore, planter row 1 will be indicated on the monitor as row 3, planter row 2 as row 4, etc. Row lamps 1, 2, 7 and 8 will be off.

If you disable the left four rows (planter rows 1, 2, 3 and 4) the monitor will operate normally as an 8 row system. Row indicators 1, 2, 3 and 4 will be off.

MACHINE OPERATION

10/92

KM1000 Bezel Decal Selection Chart

NO. ROWS	BEZEL DECAL	ROW LAMPS															
		1	2	3	4	5	6	7	8	9	10	11	12	13	14	15	16
4	12					■	■	■	■	■	■	■	■	■	■	■	■
6	6																
8	16									■	■	■	■	■	■	■	
*8	16									■	■	■	■	■	■	■	
10	12													■	■		
12	12																
*12	12																
16	16																
*4 & 3 Solid Interplant	16					■	■	■	■				■	■	■	■	
*6 & 3 Skip Row Interplant	16							■	■		■		■		■	■	
*6 & 5 Solid Interplant	16							■	■					■	■	■	
*8 & 5 Skip Row Interplant	16										■		■			■	
*8 & 7 Solid Interplant	16															■	

Row lamp indicates planter row in use.

Row lamp not used.

* With "Y" connector.

NOTE: Interplant diagrams assume that first interplant row is connected to row 1 of harness and harness is connected to R.H. half of "Y" connector.

MACHINE OPERATION

KM3000 MONITOR

D-0841-0001

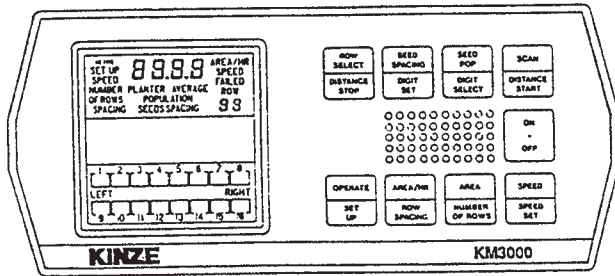

The KM3000 console may be equipped with one of two optional distance sensor features, a radar sensor which is mounted on the tractor or a pulse wheel (magnetic distance sensor) which is installed on the planter drive.

The operator's controls on the front panel of the console consist of nine pressure sensitive switches. Eight of the nine switches are dual function switches, performing one function during the OPERATE MODE and another function during the SET UP MODE. All switch functions are color coded to define between the OPERATE and SET UP modes. The upper half of each dual function switch is olive brown in color and contains the Operate functions. The lower half of each dual function switch is tan in color and contains the Set Up functions.

Turn console ON by pressing the ON-OFF switch. Note that the upper display shows random segments for a short time then sequences through all entered SET UP constants (SPEED, NUMBER OF ROWS and ROW SPACING). If the constants are not valid the alarm will sound for approximately four seconds and the monitor will enter the SET UP mode. See "Entering Constants". If all constants are valid (as previously entered) the alarm will sound momentarily and the monitor will enter the OPERATE mode.

Select the desired OPERATE function to be displayed by pressing the labelled switch.

SEED POP displays the seed population of each planter row in thousands of seeds per acre or hectare. In the SCAN mode the display will sequence through all planter rows. After the population for the highest planter row number is displayed, the average population for the total planter is shown. In the ROW SELECT mode a specific row can be selected and continuously monitored.

SEED SPACING displays the seed spacing of each planter row in inches or centimeters. In the SCAN mode the display will sequence through all planter rows. After the seed spacing for the highest planter row number is displayed, the average seed spacing for the total planter is shown. In the ROW SELECT mode a specific row can be selected and continuously monitored.

AREA/HR displays the predicted area in acres or hectares that will be covered in the next hour if the same planting rate is maintained. This prediction is based on the last 10 seconds of operation.

AREA displays the actual area covered in acres or hectares since the last reset. To reset area to 0000, press and hold the AREA switch for approximately 5 seconds.

SPEED displays current vehicle ground speed in MPH or KmPH.

A row failure will be indicated by the FAILED ROW number being displayed in the lower right hand corner of the upper display, the corresponding segment in the lower display will be blank, and the alarm will sound continuously. Failures of more than one row will be indicated by the FAILED ROW number in the upper display sequencing through all failed rows, the corresponding segments of all failed rows in the lower display will be blank, and the alarm will sound continuously. When you lift your planter at the end of a row or stop in the field and seed flow stops in all planter units, the alarm will sound for approximately four seconds and all row indicator segments (lower display) will stop flashing. The upper display will show the FAILED ROW message and will sequence through all planter row numbers.

In the all row failure mode or immediately following power up, the operate functions (population, seed spacing and area) can be displayed by pressing the touch switch labeled with the desired function. This display condition will remain for one minute after the last time a switch is pressed or until seeds are detected by the seed sensors.

MACHINE OPERATION

A ground speed failure will be indicated by the SPEED FAILED message being displayed in the upper display. To continue using the monitor system until a replacement ground speed sensor is obtained, disconnect the ground speed sensor cable, enter the SET UP mode and enter your normal planting speed in MPH or KmPH in place of the SPEED SET calibration number. **IMPORTANT:** The accuracy of the POPULATION, SEED SPACING and AREA readouts will depend on the vehicle ground speed. If you do not drive at the speed entered in SPEED SET memory these functions will not be accurate. AREA will not accumulate in this mode.

IMPORTANT: Under normal use the monitor will accumulate area whenever there is seed flow in at least one seed sensor. In the all rows failed condition, such as when turning around at the end of the field, the area accumulation will stop.

The monitor can be used to count seeds in a selected row by performing the following:

1. Place console in SET UP mode. (Before performing Step 2 make sure you have recorded the SPEED constant.)
2. Set the SPEED constant to 0000. This can be done by manually setting each digit to zero using the DIGIT SELECT and DIGIT SET switches or by pressing and holding the SPEED SET switch for approximately 5 seconds.
3. Enter the OPERATE mode by pressing the OPERATE switch.
4. Press and release the ROW SELECT switch until the desired planter row number is displayed in the lower right corner of the upper display. The monitor will now show seed counts for the selected row.

To reset the display to zero and continue to monitor the same row unit, press the SCAN switch then the ROW SELECT.

To select another row unit, press the ROW SELECT switch until the desired planter row number is displayed. Each time the ROW SELECT switch is pressed the row number will be incremented one unit and the four digit display will be reset to zero.

IMPORTANT: To return to normal operation, enter the SET UP mode and re-enter the SPEED constant.

NOTE: The KM3000 is shipped from the factory setup for use with American measures. To convert the console to Metric measures, cut the wire loop (red wire) adjacent to the signal cable on the back of the console and tape the ends of the cut wire to prevent the two ends making contact with each other or the vehicle.

LOWER DISPLAY

The lower visual display contains up to sixteen segments and each one corresponds to a planter row unit. When the monitor is turned on the console senses the number of seed sensors connected to the planter harness and activates a segment for each one which flashes dark each time a seed is detected by the seed sensor. If up to 16 seed sensors are sensed the display will show segments for all sensors all the time. If more than 16 (17-32) seed sensors are sensed, then the display is split and up to 16 sensors are shown for the LEFT and RIGHT side of the planter.

EXAMPLE: If a 24 row planter is being used and the display message LEFT is on, the segments are showing seed flow for planter rows 1 through 12. When the display message RIGHT is on, the segments are showing seed flow for planter rows 13 through 24. When the RIGHT planter half is shown, the segment numbers 1 through 12 will represent planter rows 13 through 24 (segment 1 is planter row 13, segment 2 is row 14, up to segment 12 which is row 24).

ENTERING CONSTANTS (KM3000 Only)

Upon initial power-up or whenever memory is lost the following three constants must be entered before the system will enter the "operate" mode. The following examples are for an 8 row planter with 30" row spacing.

1. ROW SPACING - The distance between the rows on your planter.

Press the "row spacing" switch. The upper display will show "set up", "row spacing" and "000.0".

Press the "digit select" switch (a short alarm burst will be heard each time the switch activates) until the second "0" to the left of the decimal point is flashing. Press the "digit set" switch until a "3" is shown in this location: 030.0.

NOTE: Holding the "digit set" switch will cause the digit to increment from 0 through 9.

NOTE: If you have a solid row planter of 15", 18", 19", 30", 36" or 38" row spacing, program that number in for row spacing. If you have a skip row planter, determine row spacing by taking the total distance between the two outside rows (in inches) and divide by the number of planter rows minus 1.

MACHINE OPERATION

EXAMPLE: 8 row 30" planter with 13 row 15" skip row interplant

Step 1. Total distance between center of outside row on left end of planter to center of outside row on right end of planter = 210"

Step 2. 13 rows (number of total rows) minus 1 = 12

Step 3. 210" ÷ 12 = 17.5" average row spacing

Step 4. Program 17.5 (round to closest tenth)

2. NUMBER OF ROWS - The number of active rows on your planter. (Example for 8 row planter)

Press the "number of rows" switch. The upper display will show "set up", number of rows" and "00".

Press the "digit set" switch until the right hand "0" is flashing.

Press the "digit set" switch until a 8 is shown in this location: 08.

3. SPEED - A number that is the result of the speed calibration procedure. Used with both radar and magnetic distance sensors.

The speed set calibration number matches the console to the ground speed sensor when calibrated over a specified measured distance. When the calibration procedure is completed and the speed set constant established, the value should be written down and retained in the event battery voltage is removed from the console and the information in memory is lost. In this event, the constant may be re-entered manually using the "digit select" and "digit set" switches. The speed set calibration procedure must be repeated and new speed set number established if the radar or magnetic distance sensor mounting is changed for any reason.

NOTE: When obtaining the following speed set number, actual in-field conditions should be simulated as close as possible.

A. Measure an accurate 400 foot (150 meter) in-field course, preferably on level ground. Mark the "start" and "finish" of the course so it will be plainly visible from the cab as you drive past.

B. With the upper display showing messages "set up" and "speed" and the four digit display showing all zeros (to reset four digit display to zeros, press and hold the "speed set" switch for approximately 5 seconds), drive up to the marked course at normal planting speed.

C. When even with the "start" marker, press the "distance start" switch. Four dashes will appear on the console display.

D. Drive at a steady speed through the entire course. When even with the "finish" marker, press the "distance stop" switch.

E. The speed set number will be displayed. Record this number for future reference.

SPEED SET NUMBER _____

IMPORTANT: This procedure may have to be repeated after performing the Radar Vibration Test. See Radar Vibration Test.

NOTE: The accuracy of the area computations, population, seed spacing and vehicle ground speed readout are dependent upon the accuracy of the operator entered constants. Use care when determining the constants which describe your planter.

RADAR VIBRATION TEST (KM3000 With Radar Sensor Only)

To check for vibration, start vehicle engine and slowly increase engine RPM (while watching the ground speed readout) to approximately 1800 RPM. If the ground speed readings are above zero, the radar sensor must be mounted in an alternate, more stable location.

INTERPLANT ROWS

The half of the "Y" connector marked row 1 is used for the main rows on the planter and the other half for interplant rows. When interplant rows are not being used, switch the console to the OFF position and disconnect the interplant rows at the "Y" connector. Switch the console back ON. It will be necessary to reprogram "row spacing" and "number of rows" on the KM3000 console.

To activate the interplant rows, switch the console to the OFF position and reconnect the interplant rows at the "Y" connector. Switch the console ON. Reprogram "row spacing" and "number of rows" on the KM3000 console.

MACHINE OPERATION

ROCK GUARDS

69797-65

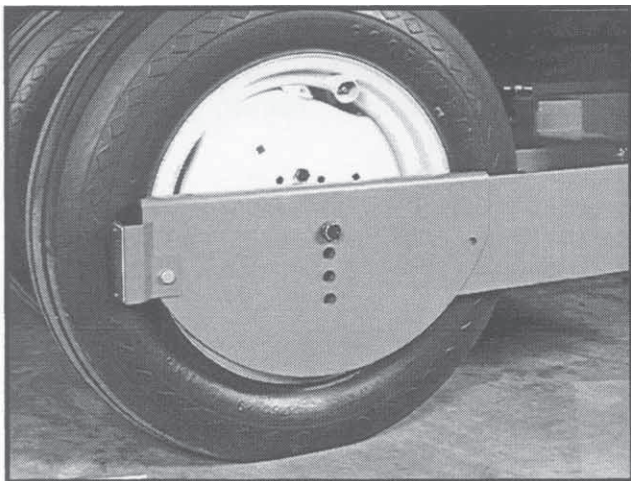

Transport wheel rock guards are designed for use on both sides of each of the four center transport wheels when the planter is used in rocky conditions. Rock guards will help prevent rocks from being picked up by the wheel causing damage to the row unit.

60607-37

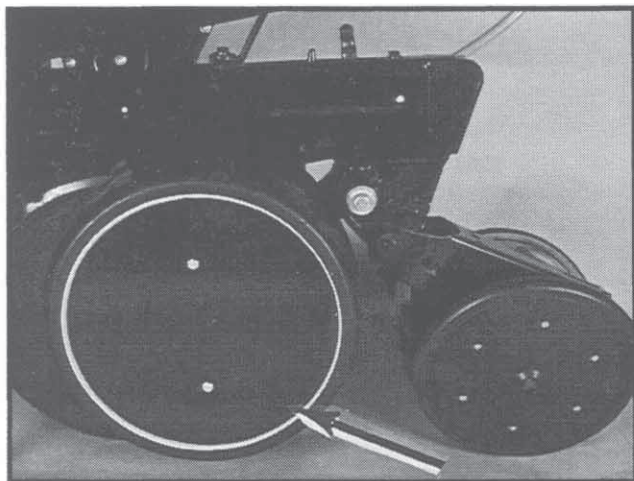

Row unit gauge wheel covers may be used in conjunction with transport wheel rock guards on row unit gauge wheels next to transport wheels.

RIDGE PLANTING

When ridge planting, the transport wheels can be lowered to the lower mounting holes in the wheel arms to increase the planter bar height. Hitch height should be raised accordingly to ensure level operation.

66337-3

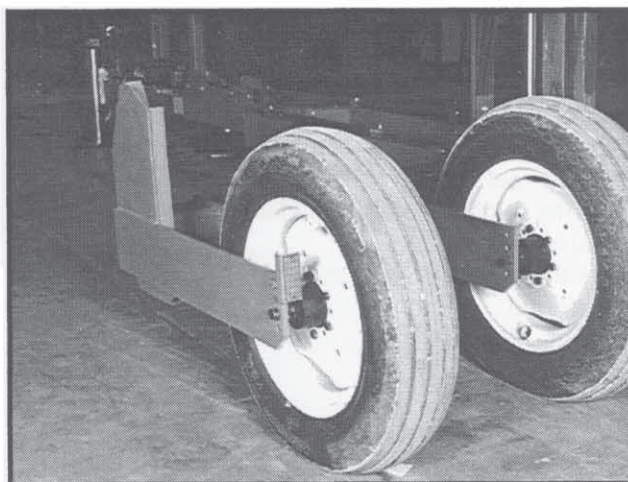

MACHINE OPERATION

TRANSPORTING THE PLANTER



WARNING: Always make sure flashing safety lights, reflectors and SMV emblem are in place and visible prior to transporting the machine on public roads. In this regard, check federal, state and local regulations.

CAUTION: Avoid transporting planter with hoppers loaded whenever possible. When it is necessary to transport the planter with the hoppers loaded, the added weight should be distributed evenly on the planter frame before rotating the planter.



Install all safety lockups and safety lock pins.

TRACTOR SPEED

Planters are designed to operate within a speed range of 2 to 8 MPH. Variations in ground speed will produce variations in rates. Finger pickup corn meter populations will tend to be disproportionately higher at high ground speeds.

FIELD TEST

With any change of field and/or planting conditions or seed size, we recommend a field test be made to ensure proper seed placement and operation of row units. See "Rate Charts", "Checking Seed Population", and "Checking Granular Chemical Application Rate" at end of this section.

Also check for any marker adjustment that may be needed.

After the planter has been field tested, reinspect the unit.

- Hoses - Fittings
- Bolts - Nuts
- Drive Chains

MACHINE OPERATION

METRIC CONVERSION TABLE

Multiply	By	To Get
Inches (in.)	x 2.54	= centimeters (cm)
Inches (in.)	x 25.4	= millimeters (mm)
Feet (ft.)	x 30.48	= centimeters (cm)
Acres	x 0.405	= hectares (ha)
Miles per hour (mph)	x 1.609	= kilometers per hour (kmph)
Pounds (lbs.)	x 0.453	= kilograms (kg)
Bushels (bu.)	x 35.238	= liters (l)
Gallons (gal.)	x 3.785	= liters (l)
Pounds per square inch (psi)	x 6.894	= kilopascals (kPa) (100 kPa = 1 bar)
Inch pounds (in. lbs.)	x 0.113	= newton-meters (N·m)
Foot pounds (ft. lbs.)	x 1.356	= newton-meters (N·m)
Centimeters (cm)	x .394	= inches (in.)
Millimeters (mm)	x .0394	= inches (in.)
Centimeters (cm)	x .0328	= feet (ft.)
Hectares (ha)	x 2.469	= acres
Kilometers per hour (kmph)	x 0.621	= miles per hour (mph)
Kilograms (kg)	x 2.208	= pounds (lbs.)
Liters (l)	x 0.028	= bushels (bu.)
Liters (l)	x 0.264	= gallons (gal.)
Kilopascals (kPa) (100 kPa = 1 bar)	x 0.145	= pounds per square inch (psi)
Newton-meters (N·m)	x 8.85	= inch pounds (in. lbs.)
Newton-meters (N·m)	x 0.738	= foot pounds (ft. lbs.)

DOUBLE DISC FERTILIZER OPENER

The double disc fertilizer openers should be positioned during assembly to place the fertilizer no closer than 2" to either side of the row. If planter frame is level and at proper planting height, fertilizer depth will be approximately 4". Soil conditions can affect depth slightly.

The down pressure spring is factory preset at 250 pounds down pressure but may be adjusted for various soil conditions. To adjust spring tension, loosen the jam nut with 15/16" wrench and use a 1" wrench to turn the adjustment bolt clockwise to increase tension or counter-clockwise to decrease tension. Securely tighten the jam nut upon completion of tension adjustment. Do not attempt to set opener depth with spring pressure. The opener is designed to operate against depth stop and spring up when encountering a foreign object or hard ground.

CAUTION: Do not operate the double disc openers at full down pressure tension when planting in rocky ground. Chipping of the blades will occur.

A gap of 1/32" to 1/16" should be maintained between the opener blades at the closest point. Blade adjustment can be made by moving inside spacer washers to the outer side of the blade. After making this adjustment, check to be sure bearing assembly rivets are not hitting shank.

60389-23

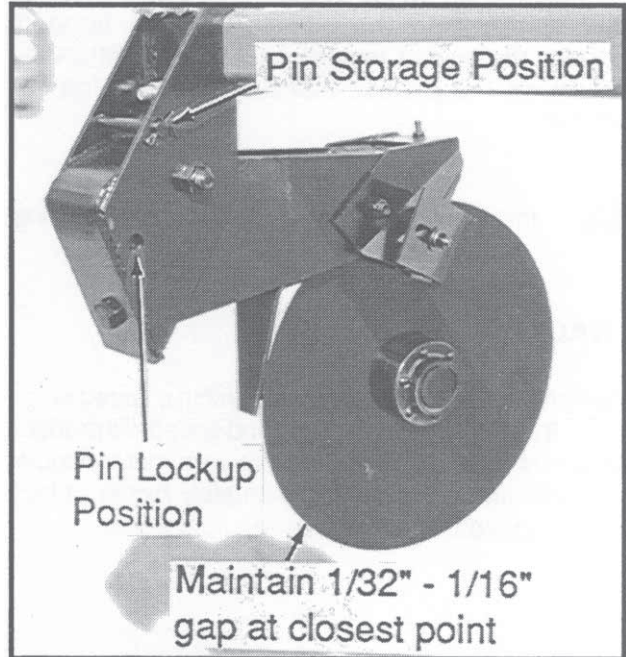

The outer scrapers on each blade may also be adjusted to make up for wear that may occur. Make sure the scraper is adjusted to allow only slight contact with the blade.

The opener assembly is designed to be locked in a raised position when the fertilizer attachment is not in use or during storage. To lock the opener, first raise the planter and place blocks under the openers. Then lower the planter until the hole in the pivot section aligns with the hole in the mounting bracket. Remove the lockup pin from the storage position in the mounting bracket and install it through the lockup hole and secure with cotter pins.



DANGER: Always install all cylinder lockup brackets before working under the unit.

MACHINE OPERATION

SINGLE DISC FERTILIZER OPENER

60389-49

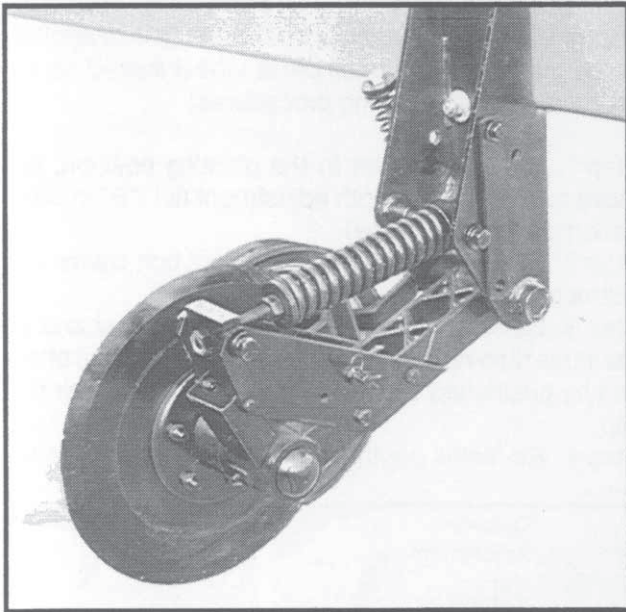

Placement of fertilizer with the single disc fertilizer opener is recommended at 3 1/2" - 4" from the row. **Never locate the opener to place fertilizer closer than 3"**. With the single disc fertilizer opener mount located centered ahead of the row unit and the rear of the blade angled away from the row, the opener will place the fertilizer 3 1/2" beside the row.

If planter frame is level and at approximately 20" planting height, maximum blade depth for placement of fertilizer is approximately 5". Soil conditions can affect depth slightly.

To adjust blade depth, raise planter to remove weight from the fertilizer opener. Loosen inside adjustment nut (A) with 1 1/8" wrench. Turn outside nut (B) clockwise to decrease blade depth or counterclockwise to increase blade depth. One full turn of blade depth adjustment nuts changes blade depth 3/8". Tighten inside nut tight against block (C). Adjust all fertilizer openers to the same depth.

L0114

(Overhead View)

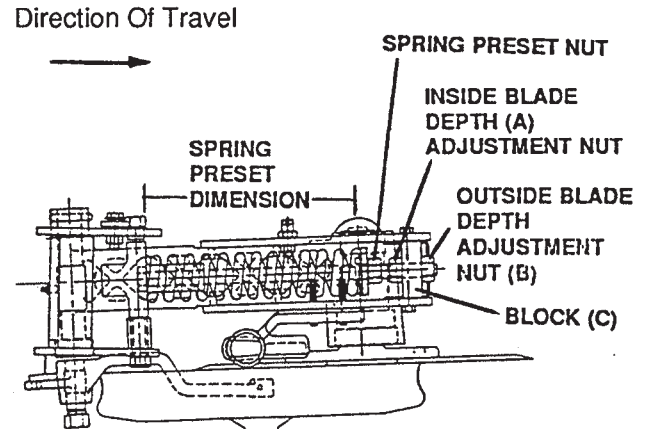

R.H. Configuration Shown

Fertilizer opener down pressure can be adjusted from 250 pounds to 640 pounds. **To make down pressure adjustments**, raise planter to remove weight from the fertilizer opener and turn spring preset nut clockwise to increase down pressure and counterclockwise to decrease down pressure. Adjust all rows to a similar setting. Minimal spring pressure for acceptable operation is recommended. See chart for setting spring length specifications.

SPRING PRESET DIMENSION	DOWN PRESSURE
11"	250 Pounds
10 3/4"	320 Pounds
*10 1/2"	370 Pounds
10 1/4"	450 Pounds
10"	520 Pounds
9 3/4"	580 Pounds
9 1/2"	640 Pounds

* Suggested initial setting.

CAUTION: DO NOT adjust spring preset dimension to less than 9 1/2"

IMPORTANT: Excessive down pressure can cause up-lift on the planter frame and affect performance of the machine. When lowered to planting position, planter frame should be at a height of approximately 20". In loose ground conditions, excessive down pressure can cause openers to run too deep and push dirt ahead of opener and may stop soil press wheel and/or opener blade from turning.



DANGER: Always install all lockup brackets before working under the machine.

MACHINE OPERATION

CAUTION: Do not operate the single disc openers at full down pressure tension when planting in rocky ground. Chipping or breakage of the blade will occur.

The spring loaded scraper should be adjusted periodically to maintain 1/8" between drop tube and opener blade. If this dimension is not maintained the fertilizer may not drop into the proper location.

60607-32

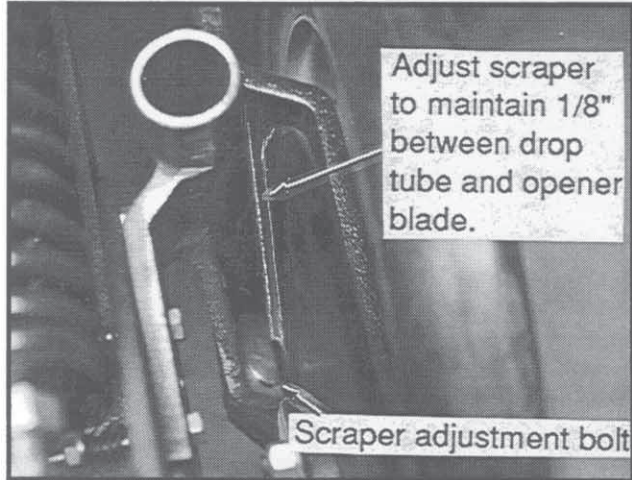

Additional press wheel down pressure may be desirable in heavy moist soils. **To increase press wheel spring pressure** turn press wheel spring adjustment bolt clockwise.

60389-63

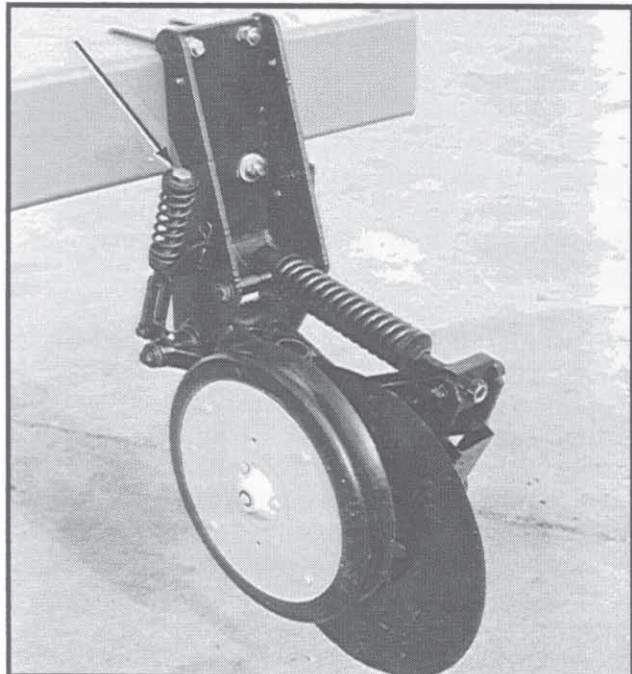

NOTE: The soil press wheel is not intended to be used for gauging fertilizer opener operating depth.

The single disc fertilizer opener is designed to be locked in a raised position when the fertilizer attachment is not in use or during storage. To accomplish this the fertilizer opener blade is raised out of the ground and the soil press wheel locked up as instructed in the following procedures:

Step 1. With the planter in the planting position, remove outside blade depth adjustment nut ("B" in illustration on previous page).

Step 2. Raise planter until adjustment bolt clears adjustment block.

Step 3. Raise spring to clear blade assembly and at the same time raise blade assembly until storage strap can be positioned onto lockup pin and install hair pin clip.

Step 4. Re-install depth adjustment nut and tighten.

60356-4

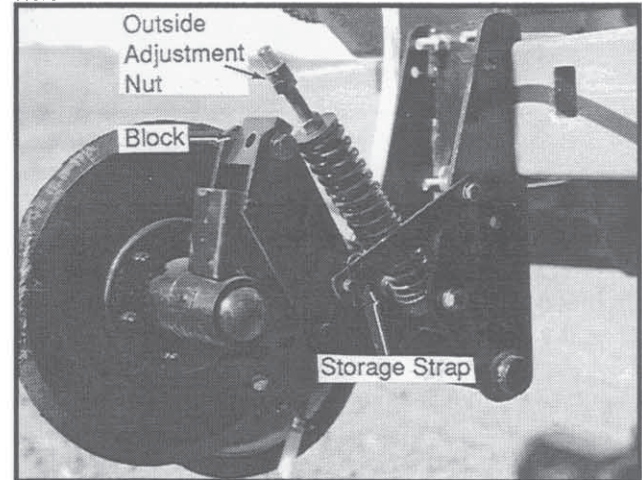

Step 5. Raise soil press wheel until lockup hole in soil press wheel spring adjustment bolt is visible. Remove hair pin clip from storage position and install in lockup hole.

60389-63



60355-32



MACHINE OPERATION

DRY FERTILIZER ATTACHMENT

69797-89

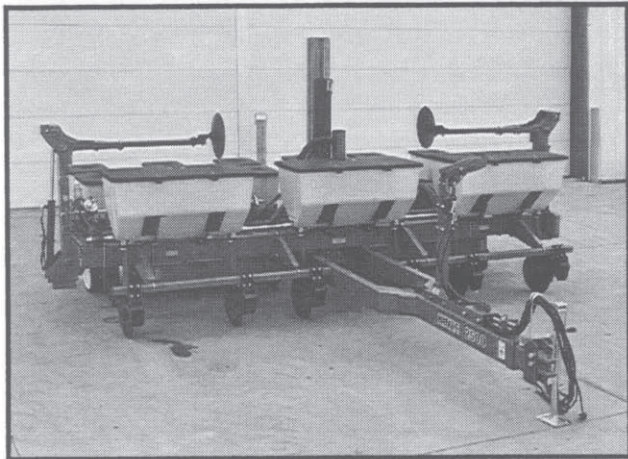

Shown with optional double disc fertilizer openers

The rate of fertilizer application is determined by the drive/driven sprocket combination on the fertilizer drive and by the auger position in the hopper.

69797-4

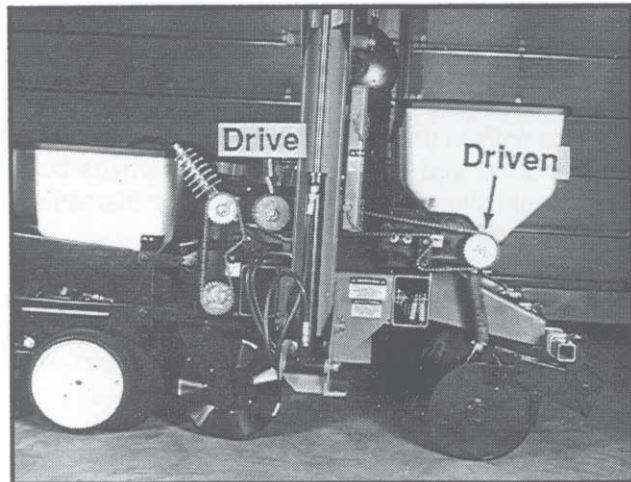

Shown with augers positioned for low rate delivery

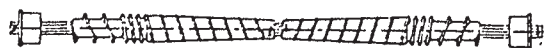

Shown with augers positioned for high rate delivery

Remove 1/4" stainless steel cap screws holding augers in place on shaft and reposition augers to change delivery rate.

See Dry Fertilizer Application Rate Chart at the end of this section. Uneven delivery of fertilizer will occur if the high rate position is used at too low a rate setting.

A fertilizer transmission is located on the end of the planter directly ahead of the row unit transmission. This transmission is designed to allow simple, rapid changes in sprockets to obtain the desired fertilizer application rates. By removing the pins on the hexagon shafts, sprockets can be interchanged with those on the sprocket storage rod bolted to the transmission plate. Chain tension is controlled by a spring loaded idler. This idler is adjusted with a ratchet arm located to the inside of the transmission. This arm has a release position to remove spring tension for replacing sprockets. The amount of spring tension on the chain can be controlled by the ratchet arm. The fertilizer application charts found at the end of this section will aid you in selecting the correct sprocket combinations.

IMPORTANT: After each sprocket combination adjustment, make a field check to be sure you are applying fertilizer at the desired rate.

The dry fertilizer attachment meters granules by volume rather than weight. For this reason, and given the variances in brands and fertilizer analysis, the weight metered during actual application may vary considerably. Use the chart for reference only. It is suggested that a container be used to catch and measure application (as explained following the application chart) to obtain a closer estimate.

Since most fertilizers easily absorb moisture, it is important that fertilizer be kept dry during use and storage. In addition to waste, deposits of fertilizer left in the hopper can cause metal corrosion. Hoppers should be emptied at the end of each day's use.

IMPORTANT: Certain analysis of fertilizer, if placed too close to the seed, may cause germination or seedling damage especially if used in amounts in excess of fertilizer manufacturer's recommendations. Check with your fertilizer dealer or manufacturer for the correct amount and placement.



WARNING: Agricultural chemicals can be dangerous if not selected and handled with care. Always read and follow directions supplied by the chemical manufacturer.

MACHINE OPERATION

CLEANING

The dry fertilizer hoppers are designed to tip forward for dumping and ease of cleaning. To dump hoppers, first disconnect the drive shaft from the transmission or adjacent hopper. Remove the two rear 1/2" cap screws from between hopper mount and mnting angle. Rotate hopper lids to the back side of the hopper and carefully tip hopper forward. After dumping contents, flush all loose fertilizer from the hopper and hoses.

69797-85

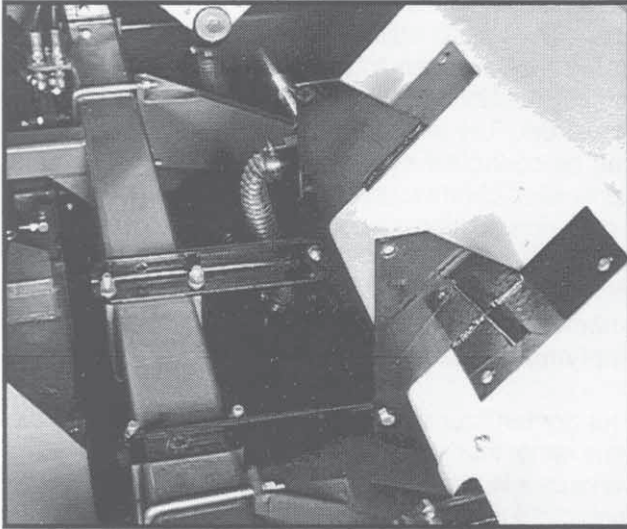

At the end of the planting season, or when fertilizer attachment is not going to be used for a period of time, the hoppers should be disassembled, cleaned and coated with a rust preventative.

To disassemble auger assemblies, remove 1/4" cotter pin and bearing from one end of the shaft. Pull auger assembly from opposite end of hopper. Remove stainless steel cap screws from auger shaft and remove all auger components for cleaning. Coat all parts with rust preventative before reassembly. Reinstall auger halves in proper low rate or high rate position.

To reassemble, slide auger assembly through the outlet housing back into the hopper. Secure in place by reinstalling the bearing and cotter pin.

59542-38

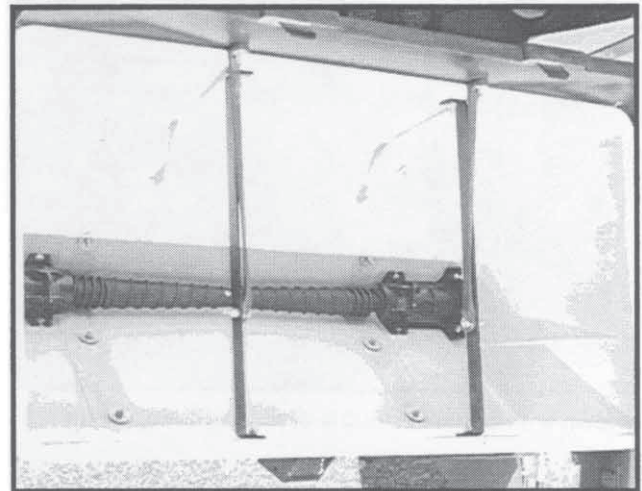

Check auger installation by rotating shaft in the direction of planter travel to see that the spirals on the auger move toward the ends of the hopper. If not, remove auger assembly, turn 180° and reinstall.

Be certain augers turn freely. If not, loosen the 5/16" carriage bolts in the outlet housings, rotate the auger several times and retighten the 5/16" carriage bolts. This should allow the housings to realign themselves with the auger.

Install auger baffles over the augers and secure in place with two hair pin clips in each hopper. Do not operate fertilizer attachment without auger baffles in place.

IMPORTANT: Frequent lubrication of auger bearings is critical to ensure that the augers will turn freely. Check lubrication section for frequency.

NOTE: Be sure the auger assembly is installed so the flighting on the augers move material to the outer openings in the hopper when the augers are rotated in the direction they will turn when the planter is in operation.

MACHINE OPERATION

LIQUID FERTILIZER ATTACHMENT

OPTIONAL SQUEEZE PUMP

69922-26

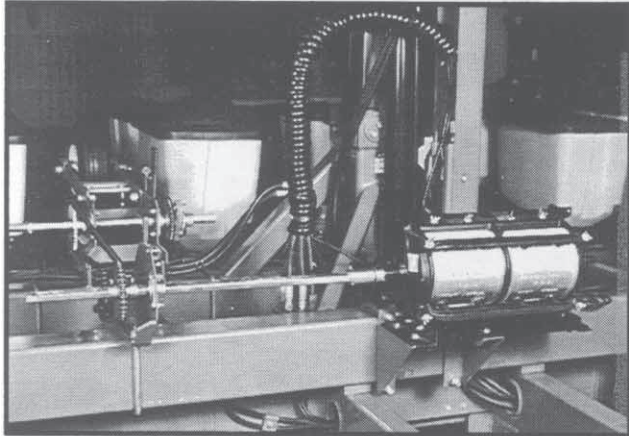

On machines equipped with the squeeze pump option, the rate of liquid fertilizer application is determined by the combination of sprockets on the squeeze pump driven and drive shafts. When changing sprocket combinations, make sure sprockets are in alignment, sprocket retaining collars are tight and chain tension is sufficiently restored.

The delivery rate chart found at the end of this section provides an approximate application rate only. Actual delivery will vary with temperature and the particular fertilizer being used.

IMPORTANT: Certain analysis of fertilizer, if placed too close to the seed, may cause germination or seedling damage especially if used in amounts in excess of fertilizer manufacturers recommendations. Check with your fertilizer dealer or manufacturer for the correct amount and placement.

! **WARNING:** Agricultural chemicals can be dangerous if not selected and handled with care. Always read and follow directions supplied by the chemical manufacturer.

Shut-off valves provided at various locations should be closed to shut off flow when the planter sets overnight or for extended periods of time. It is also important to close the tank valves whenever service on the pump or hoses is being performed. To prolong the life of the hoses in the squeeze pump, the discharge manifold must be repositioned to the rearward position when not in use to prevent hose distortion.

00137-6

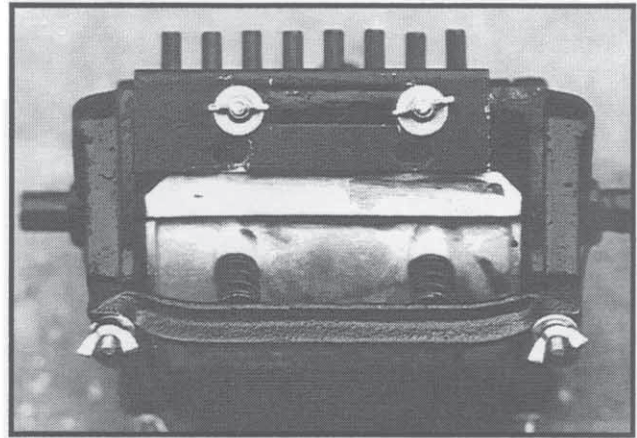

Discharge Manifold Rearward

00137-7

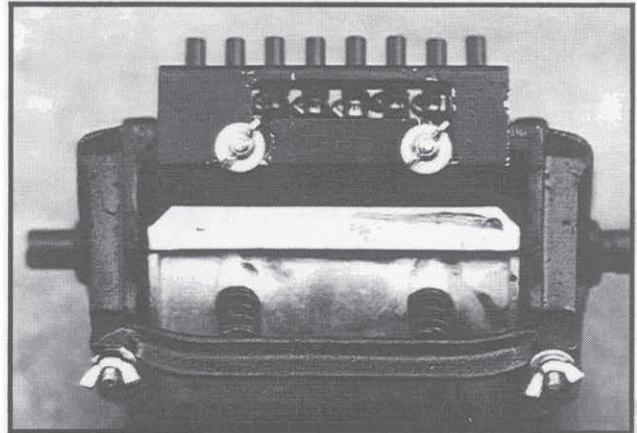

Discharge Manifold Forward

The discharge manifold must be in the forward position when the pump is in operation. To reposition the manifold, loosen the wing nuts and slide the manifold forward and sideways or rearward as required and retighten nuts.

CAUTION: Avoid excessive pressure when using the quick fill attachment. The rubber plugs installed in the manifold may be forced out under pressure.

MACHINE OPERATION

If either of the end pump hoses should run off the back plate, loosen the hose clamp on the intake manifold and rotate the hose as follows:

61010-5

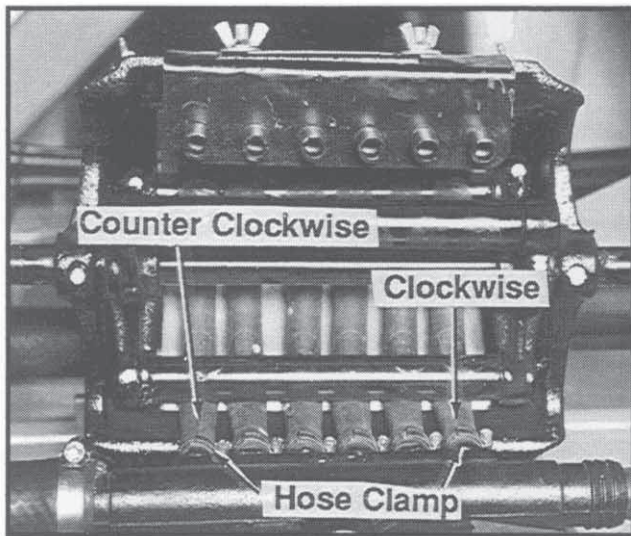

For the right hand hose (facing the pump from front of planter) twist the hose 1/4 turn in the clockwise direction.

For the left hand hose (facing front of pump) twist the hose 1/4 turn in the counter-clockwise direction.

Retighten hose clamp.

OPTIONAL PISTON PUMP

69922-31

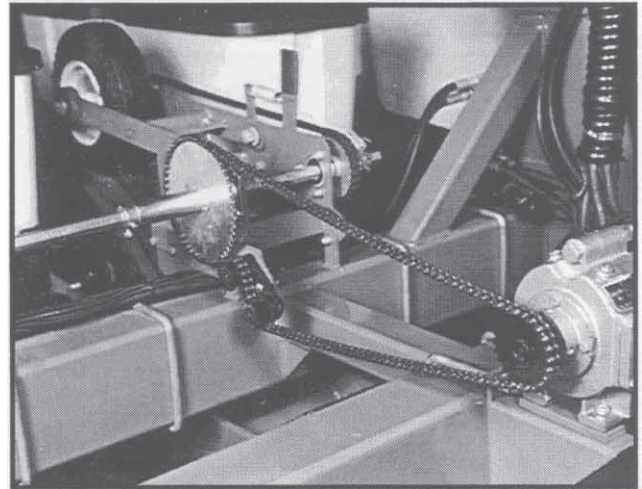

If the machine is equipped with the piston pump option, the rate of liquid fertilizer application is determined by the piston pump settings.

The delivery rate chart found at the end of this section provides an approximate application rate only. Actual delivery will vary with temperature and the particular fertilizer being used.

The operator and instruction manual shipped with the pump and flow divider should be kept and stored with this manual for future reference.

CLEANING

The tanks and all hoses are made of sturdy plastic and rubber to resist corrosion. However, the tanks, hoses and metering pump should be thoroughly cleaned with water at the end of the planting season or prior to an extended period of non-use. Do not allow fertilizer to crystalize due to cold temperature or evaporation.

MACHINE OPERATION

CHECKING SEED POPULATION

1. Tie up one or more sets of closing wheels by running a light chain between the hopper support panel and closing wheels. It may be necessary to decrease closing wheel arm spring tension.

L0069

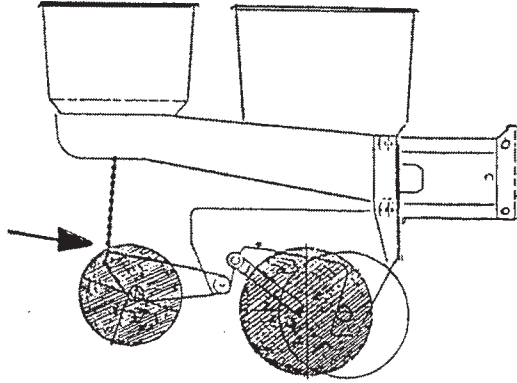

2. Plant a short distance and check to see if seed is visible in the seed trench. Adjust planting depth to a shallower setting if seed is not visible and recheck.

50677-13

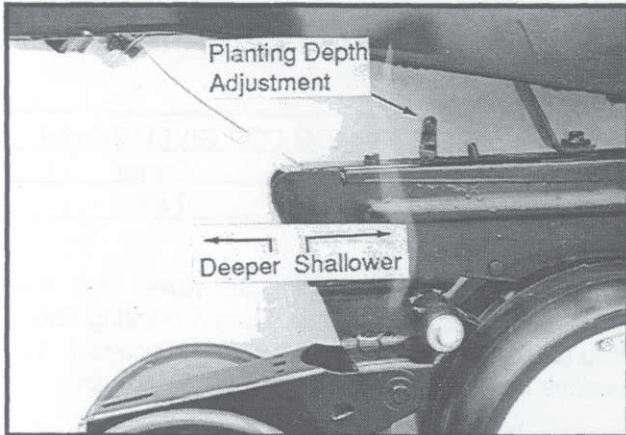

3. Measure 1/1000 of an acre. See chart for correct distance for row width spacing being planted. For example, if planting 30" rows 1/1000 of an acre would be 17'5".

LENGTH OF ROW IN FEET AND INCHES		
Fraction Of Acre	Row Width	
	15"	30"
1/1000	34'10"	17'5"

NOTE: When planting with closing wheels raised and planting depth set shallow, seeds may bounce or roll affecting seed spacing accuracy.

4. Count seeds in measured distance.

5. Multiply the number of seeds placed in the 1/1000 of an acre by 1000. This will give you total population.

EXAMPLE: With 30" row spacing 17'5" equals 1/1000 acre.

26 Seeds Counted	x	1000	=	26,000 Seeds Per Acre
---------------------	---	------	---	-----------------------

Seed count can be affected by drive ratio between drive wheel and seed meter, tire pressure and/or seed meter malfunction.

If seed check shows the average distance between seeds in inches is significantly different than the seed rate chart indicates, first check drive ratio between drive wheel and seed meter. Check drive wheel air pressure, check for incorrect sprocket(s) in drive line and check drive and driven sprockets in transmission for proper selection.

Second, check for seed meter malfunction. For example, if spacing between kernels of corn at the transmission setting being used is 8" and a gap of 16" is observed, a finger has lost its seed and not functioned properly. If two seeds are found within a short distance of each other, the finger has metered two seeds instead of one.

See "Finger Pickup Corn Meter Troubleshooting" and/or "Brush-Type Seed Meter Troubleshooting" in the Row Unit Operation Section of this manual.

MACHINE OPERATION

Determining Pounds Per Acre (Brush-Type Seed Meter)

To determine pounds per acre:

Seeds Per Acre On Chart	+	Seeds Per Pound From Seed Tag On Bag	=	Pounds Per Acre
-------------------------------	---	---	---	-----------------------

To determine bushels per acre:

Pounds Per Acre	+	Unit Weight Of Seed	=	Bushels Per Acre
--------------------	---	------------------------	---	---------------------

The unit weight of:

- 1 Bushel Soybeans = 60 Pounds
- 1 Bushel Cottonseed = 32 Pounds
- 1 Bushel Milo = 56 Pounds

If seeds per pound information is not available the following is an average:

- 2,600 seeds per pound for medium size soybeans
- 15,000 seeds per pound for medium size milo
- 4,500 seeds per pound for medium size cotton

If seed check shows planting rate is significantly different than seed rate chart shows or if a particular meter is not planting accurately, remove seed disc and check meter for buildup of foreign material in the meter or the brush. Check the brush for damaged bristles. Remove foreign material from meter and replace upper and lower brushes if necessary.

CHECKING GRANULAR CHEMICAL APPLICATION RATE

Many things can affect the rate of delivery of granular chemicals. Temperature, humidity, speed, ground conditions, flowability of different material or any obstruction in the meter.

A field check is important to determine correct application rates.

60569-39

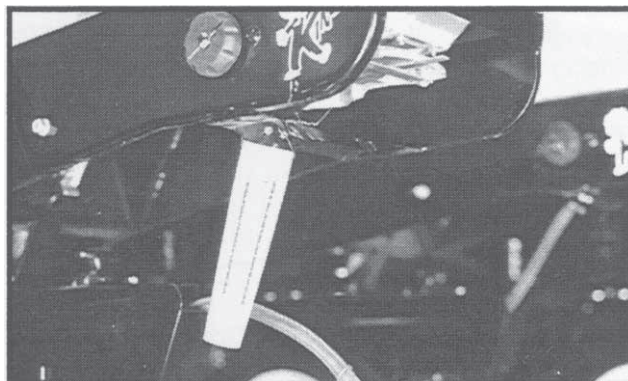

To check, fill insecticide and/or herbicide hoppers. Attach a calibrated vial to each granular diffuser. Lower the planter and proceed as follows.

NOTE: It is not necessary for seed meter clutch to be engaged during test. Disengage clutch to avoid dropping seed.

Drive 1320 feet at planting speed. Weigh the chemical in ounces that was caught in one vial. Multiply that amount by the factor shown to determine pounds per acre.

LBS. PER ACRE FACTOR FOR GIVEN WIDTH	
Row Width	Factor
30 Inch	0.83

EXAMPLE: You are planting 30" rows. You have planted for 1320 feet at the desired planting speed. You caught 12.0 ounces of chemical in one vial. 12.0 ounces times 0.83 equals 9.96 pounds per acre.

NOTE: It is important to check calibration of all rows.

Metering Gate

Use the metering gate setting for distributing insecticide or herbicide as a starting point. The chart is based on a 5 miles per hour planting speed. For speeds faster than 5 miles per hour a higher gate setting should be used. For speeds slower than 5 miles per hour a lower gate setting should be used.



WARNING: Agricultural chemicals can be dangerous if not selected and handled with care. Always read and follow directions supplied by the chemical manufacturer.

MACHINE OPERATION

GENERAL PLANTING RATE INFORMATION

These planting rate charts are applicable to KINZE Model 2500 Planters. See "Tire Pressure" for recommended tire pressures.

IMPORTANT: The sprocket combinations listed in these charts are best for average conditions. Changes in sprocket combinations may be required to obtain desired planting population. TO PREVENT PLANTING MISCALCULATIONS, MAKE FIELD CHECKS TO BE SURE YOU ARE PLANTING AT THE DESIRED RATE.

The size and shape of seed may affect the planting rate.

Finger Pickup Corn Meter

Larger grades will generally plant more accurately at the high end of the ground speed range than small grades. Higher than optimum speeds may result in population rate increase or higher incidence of doubles, particularly with small seed.

Brush-Type Seed Meter (Soybean, Milo/Sorghum, Acid-delinted Cotton)

Rate charts are given in seeds per acre as well as seed spacing in inches rounded off to the nearest tenth of an inch. Because of the large range in seed size, pounds per acre is not a suggested method of selecting transmission settings. When using smaller size seeds it may appear the pounds per acre is below what was expected and vice versa on large seed. To determine pounds per acre, use the formula given in "Determining Pounds Per Acre (Brush-Type Seed Meter)" in the "Checking Seed Population" section of this manual.

Seed population per acre with 15" rows will be double the rate for 30" rows at the listed sprocket combination.

In some cases when planting in 15" rows, a 2 to 1 drive reduction package may be required to obtain the desired population and seed spacing.

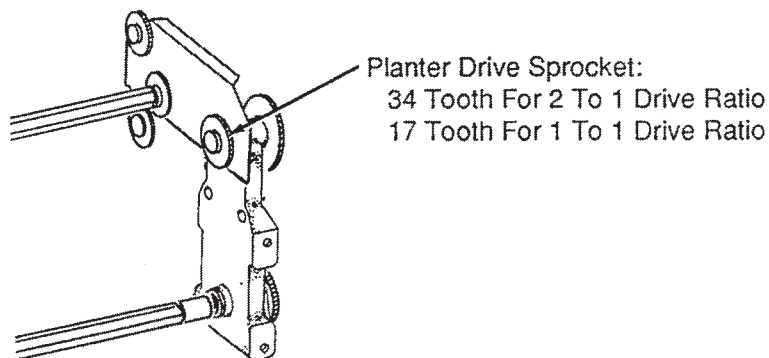

NOTE: Use of the 2 to 1 drive reduction package will reduce the planter transmission speed. The seeding rate will be approximately 1/2 of the chart reading when using the 2 to 1 drive reduction package. Planting speed can affect actual seeding rate. Make a field check and adjust setting in the transmission as needed to obtain the desired seed drop.

MACHINE OPERATION

Z202

PLANTING RATES FOR FINGER PICKUP CORN METERS APPROXIMATE SEED POPULATIONS/ACRE FOR 30" ROW WIDTH

30 Inch Row	Transmission Sprockets		Recommended Speed Range (MPH)	Average Seed Spacing In Inches
	Drive	Driven		
16,186	17	28	4 to 8	12.9
16,785	17	27	4 to 8	12.5
17,431	17	26	4 to 8	12.0
18,090	19	28	4 to 8	11.6
18,128	17	25	4 to 8	11.5
18,760	19	27	4 to 8	11.1
18,883	17	24	4 to 8	11.1
19,481	19	26	4 to 8	10.7
19,704	17	23	4 to 8	10.6
20,261	19	25	4 to 8	10.3
21,104	19	24	4 to 8	9.9
21,898	23	28	4 to 8	9.5
22,022	19	23	4 to 8	9.5
22,709	23	27	4 to 8	9.2
22,850	24	28	4 to 8	9.2
23,583	23	26	4 to 8	8.9
23,697	24	27	4 to 8	8.8
23,802	25	28	4 to 8	8.8
23,853	17	19	4 to 7.5	8.8
24,526	23	25	4 to 7.5	8.5
24,608	24	26	4 to 7.5	8.5
24,684	25	27	4 to 7.5	8.5
24,755	26	28	4 to 7.5	8.4
25,548	23	24	4 to 7.5	8.2
25,592	24	25	4 to 7.5	8.2
25,633	25	26	4 to 7.5	8.2
25,671	26	27	4 to 7.5	8.1
25,707	27	28	4 to 7.5	8.1
26,659	23	23	4 to 7	7.8
27,646	28	27	4 to 7	7.6
27,684	27	26	4 to 7	7.6
27,770	25	24	4 to 7	7.5
27,818	24	23	4 to 7	7.5
28,709	28	26	4 to 6.5	7.3
28,791	27	25	4 to 6.5	7.3
28,977	25	23	4 to 6.5	7.2
29,795	19	17	4 to 6.5	7.0
29,858	28	25	4 to 6.5	7.0
29,991	27	24	4 to 6.5	7.0
30,136	26	23	4 to 6.5	7.0
31,102	28	24	3 to 6	6.7
31,295	27	23	3 to 6	6.7
32,271	23	19	3 to 5.5	6.5
32,454	28	23	3 to 5.5	6.5
33,674	24	19	3 to 5.5	6.2
35,077	25	19	3 to 5	6.0
36,068	23	17	3 to 5	5.8
36,480	26	19	3 to 5	5.7
37,636	24	17	3 to 5	5.6
37,883	27	19	3 to 5	5.5
39,204	25	17	3 to 4.5	5.3
39,287	28	19	3 to 4.5	5.3
40,772	26	17	3 to 4.5	5.1
42,340	27	17	3 to 4.5	4.9
43,908	28	17	3 to 4.5	4.8

IMPORTANT: See "General Planting Rate Information" and "Checking Seed Population" pages for additional information. Always check seed population in the field to ensure planting rates are correct.

MACHINE OPERATION

Z214/RH

PLANTING RATES FOR BRUSH-TYPE SEED METERS

APPROXIMATE SEEDS/ACRE FOR 30" ROW WIDTH

Transmission Sprockets		60 Cell Soybean Or High Rate Milo/ Grain Sorghum	Average Seed Spacing In Inches	48 Cell Specialty Soybean Or High Rate Acid-delinted Cotton	Average Seed Spacing In Inches	Speed Range (MPH)
Drive	Driven					
17	28	80,928	2.6	64,742	3.2	2 to 8
17	27	83,926	2.5	67,141	3.1	2 to 8
17	26	87,154	2.4	69,723	3.0	2 to 8
19	28	90,449	2.3	72,359	2.9	2 to 8
19	27	93,799	2.2	75,039	2.8	2 to 8
17	24	94,416	2.2	75,533	2.8	2 to 8
17	23	98,521	2.1	78,817	2.7	2 to 8
19	25	101,303	2.1	81,042	2.6	2 to 8
19	24	105,524	2.0	84,419	2.5	2 to 8
23	28	109,491	1.9	87,593	2.4	2 to 8
19	23	110,112	1.9	88,090	2.4	2 to 8
24	28	114,252	1.8	91,402	2.3	2 to 8
24	27	118,483	1.8	94,786	2.2	2 to 8
17	19	119,263	1.8	95,410	2.2	2 to 8
24	26	123,040	1.7	98,432	2.1	2 to 8
26	28	123,773	1.7	99,018	2.1	2 to 8
24	25	127,962	1.6	102,370	2.0	2 to 8
26	27	128,357	1.6	102,686	2.0	2 to 8
23	23	133,294	1.6	106,635	2.0	2 to 8
27	26	138,420	1.5	110,736	1.9	2 to 8
24	23	139,089	1.5	111,271	1.9	2 to 8
25	23	144,884	1.4	115,907	1.8	2 to 8
19	17	148,975	1.4	119,180	1.8	2 to 8
27	24	149,955	1.4	119,964	1.7	2 to 8
28	24	155,509	1.3	124,407	1.7	2 to 8
23	19	161,355	1.3	129,084	1.6	2 to 8
28	23	162,270	1.3	129,816	1.6	2 to 8
24	19	168,371	1.2	134,696	1.6	2 to 8
25	19	175,386	1.2	140,309	1.5	2 to 8
23	17	180,338	1.2	144,270	1.5	2 to 8
26	19	182,402	1.1	145,922	1.4	2 to 7
27	19	189,417	1.1	151,534	1.4	2 to 7
28	19	196,433	1.1	157,146	1.3	2 to 7
26	17	203,861	1.0	163,089	1.3	2 to 7
27	17	211,702	0.9	169,362	1.2	2 to 7
28	17	219,542	0.9	175,634	1.2	2 to 7

IMPORTANT: See "General Planting Rate Information" and "Checking Seed Population" pages for additional information.

NOTE: When using the 2 to 1 Drive Reduction Package, rates will be approximately 1/2 of given numbers.

IMPORTANT: Always check seed population in the field to ensure planting rates are correct.

MACHINE OPERATION

RH/Z215

PLANTING RATES FOR BRUSH-TYPE SEED METERS (Continued)

APPROXIMATE SEEDS/ACRE FOR 30" ROW WIDTH

Transmission Sprockets		36 Cell Acid-delinted Large Cotton	Average Seed Spacing In Inches	30 Cell Milo/Grain Sorghum Or Acid-delinted Cotton	Average Seed Spacing In Inches	Speed Range (MPH)
Drive	Driven	30 Inch Row		30 Inch Row		
17	28	48,557	4.3	40,464	5.2	2 to 8
17	27	50,356	4.2	41,963	5.0	2 to 8
17	26	52,292	4.0	43,577	4.8	2 to 8
19	28	54,269	3.9	45,225	4.6	2 to 8
19	27	56,279	3.7	46,900	4.5	2 to 8
17	24	56,650	3.7	47,208	4.4	2 to 8
17	23	59,113	3.5	49,261	4.2	2 to 8
19	25	60,782	3.4	50,652	4.1	2 to 8
19	24	63,314	3.3	52,762	4.0	2 to 8
23	28	65,695	3.2	54,746	3.8	2 to 8
19	23	66,067	3.2	55,056	3.8	2 to 8
24	28	68,551	3.0	57,126	3.7	2 to 8
24	27	71,090	2.9	59,242	3.5	2 to 8
17	19	71,558	2.9	59,631	3.5	2 to 8
24	26	73,824	2.8	61,520	3.4	2 to 8
26	28	74,264	2.8	61,886	3.4	2 to 8
24	25	76,772	2.7	63,981	3.3	2 to 8
26	27	77,014	2.7	64,178	3.3	2 to 8
23	23	79,976	2.6	66,647	3.1	2 to 8
27	26	83,052	2.5	69,210	3.0	2 to 8
24	23	83,453	2.5	69,544	3.0	2 to 8
25	23	86,930	2.4	72,442	2.9	2 to 8
19	17	89,385	2.3	74,488	2.8	2 to 8
27	24	89,973	2.3	74,978	2.8	2 to 8
28	24	93,305	2.2	77,755	2.7	2 to 8
23	19	96,813	2.2	80,678	2.6	2 to 8
28	23	97,362	2.1	81,135	2.6	2 to 8
24	19	101,023	2.1	84,185	2.5	2 to 8
25	19	105,232	2.0	87,693	2.4	2 to 8
23	17	108,233	1.9	90,169	2.3	2 to 8
26	19	109,441	1.9	91,201	2.3	2 to 7
27	19	113,650	1.8	94,709	2.2	2 to 7
28	19	117,860	1.8	98,216	2.1	2 to 7
26	17	122,317	1.7	101,930	2.1	2 to 7
27	17	127,021	1.6	105,851	2.0	2 to 7
28	17	131,725	1.6	109,771	1.9	2 to 7

IMPORTANT: See "General Planting Rate Information" and "Checking Seed Population" pages for additional information.

NOTE: When using the 2 to 1 Drive Reduction Package, rates will be approximately 1/2 of given numbers.

IMPORTANT: Always check seed population in the field to ensure planting rates are correct.

MACHINE OPERATION

Z202

PLANTING RATES FOR BRUSH TYPE SEED METERS (Continued) APPROXIMATE HILLS/ACRE FOR 30" ROW WIDTH

Due to variations in cotton seed size, meters equipped with the 12 cell acid-delinted hill-drop cotton disc will plant from 3 to 6 seeds per cell.

To determine planter transmission setting: determine desired hill spacing and select the transmission ratio closest to the hill spacing in inches on the chart. To decrease population increase spacing. To increase population decrease spacing.

To determine population per acre: determine average seeds per hill and hills per acre by doing a field check. Measure 1/1000 of an acre (1/1000 acre = Length of row 17' 5" for 30" row width). Multiply average seeds per hill by hills per acre. **EXAMPLE:** 4 seeds per hill x (13 hills x 1000) = 52,000

Transmission Sprockets		NUMBER OF HILLS PER ACRE 12 Cell Hill-drop Cotton, Acid-delinted	Average Hill Spacing In Inches	Speed Range (MPH)
Drive	Drive	30 Inch Row		
17	28	16,186	12.9	2 to 8
17	27	16,785	12.5	2 to 8
17	26	17,431	12.0	2 to 8
19	28	18,090	11.6	2 to 8
19	27	18,760	11.1	2 to 8
17	24	18,883	11.1	2 to 8
17	23	19,704	10.6	2 to 8
19	25	20,261	10.3	2 to 8
19	24	21,105	9.9	2 to 8
23	28	21,898	9.5	2 to 8
19	23	22,022	9.5	2 to 8
24	28	22,850	9.2	2 to 8
24	27	23,697	8.8	2 to 8
17	19	23,853	8.8	2 to 8
24	26	24,608	8.5	2 to 8
26	28	24,755	8.4	2 to 8
24	25	25,592	8.2	2 to 8
26	27	25,671	8.1	2 to 8
23	23	26,659	7.8	2 to 8
27	26	27,684	7.6	2 to 8
24	23	27,818	7.5	2 to 8
25	23	28,977	7.2	2 to 8
19	17	29,795	7.0	2 to 8
27	24	29,991	7.0	2 to 8
28	24	31,102	6.7	2 to 8
23	19	32,271	6.5	2 to 8
28	23	32,454	6.5	2 to 8
24	19	33,674	6.2	2 to 8
25	19	35,077	6.0	2 to 8
23	17	36,068	5.8	2 to 8
26	19	36,480	5.7	2 to 7
27	19	37,883	5.5	2 to 7
28	19	39,287	5.3	2 to 7
26	17	40,772	5.1	2 to 7
27	17	42,340	4.9	2 to 7
28	17	43,908	4.8	2 to 7

IMPORTANT: See "General Planting Rate Information" and "Checking Seed Population" pages for additional information.

NOTE: When using the 2 to 1 Drive Reduction Package, rates will be approximately 1/2 of given numbers.

IMPORTANT: Always check seed population in the field to ensure planting rates are correct.

MACHINE OPERATION

DRY INSECTICIDE APPLICATION RATES APPROXIMATE POUNDS/ACRE AT 5 MPH FOR 30" ROW WIDTH

Meter Setting	30 Inch Row
CLAY GRANULES	
10	4.9
11	5.4
12	6.1
13	6.9
14	7.7
15	8.5
16	9.6
17	10.7
18	11.4
19	13.1
20	14.2
21	15.5
22	16.4
23	17.2
24	18.8
25	20.9
26	23.0
27	24.1
28	25.4
29	27.8
30	29.6
SAND GRANULES	
5	2.9
6	4.9
7	5.3
8	6.3
9	7.8
10	8.9
11	10.2
12	11.2
13	12.6
14	14.1
15	15.5
16	17.5
17	19.4
18	21.8
19	24.3
20	25.7
21	27.6
22	29.6
23	32.0
24	34.4
25	36.9

IMPORTANT: The above chart represents average values and should be used only as a starting point. The granular chemical flows through the given meter opening at a nearly uniform rate regardless of roller speed. Your actual rate will vary depending upon the insecticide you are using, your planting speed and your plant population. Planting speed/ground speed has the greatest affect on application rate.

Your actual rate must be checked in the field with the actual insecticide that you are using and at the speed and population at which you will be planting.

MACHINE OPERATION

DRY HERBICIDE APPLICATION RATES

APPROXIMATE POUNDS/ACRE AT 5 MPH FOR 30" ROW WIDTH

CLAY GRANULES

Meter Setting	30 Inch Row
10	4.7
11	5.2
12	5.8
13	6.5
14	7.3
15	8.2
16	9.0
17	9.9
18	10.7
19	11.6
20	12.6
21	13.6
22	14.6
23	15.7
24	17.0
25	18.1
26	19.4
27	20.9
28	22.6
29	24.3
30	26.7

IMPORTANT: The above chart represents average values and should be used only as a starting point. The granular chemical flows through the given meter opening at a nearly uniform rate regardless of roller speed. Your actual rate will vary depending upon the herbicide you are using, your planting speed and your plant population. Planting speed/ground speed has the greatest affect on application rate.

Your actual rate must be checked in the field with the actual herbicide that you are using and at the speed and population at which you will be planting.

MACHINE OPERATION

DRY FERTILIZER APPLICATION RATES

APPROXIMATE RATE IN POUNDS PER ACRE

Drive Sprocket	Driven Sprocket	Low Rate Setting	High Rate Setting
		30 Inch Row	30 Inch Row
15	33	36	109
15	30	39	120
30	50	47	144
19	30	50	153
33	50	52	158
15	19	58	174
30	33	67	200
33	30	81	241
19	15	93	278
50	33	111	332
30	19	116	347
50	30	122	365
33	19	127	382
30	15	146	440
33	15	161	482
50	19	193	578
50	15	244	730

NOTE: Uneven delivery may result in attempting to use lower rates than indicated by the chart.

Direction
Of Rotation



High Rate Position



Low Rate Position

Above chart for planters equipped with contact drive. See "Tire Pressure" for recommended tire pressures.

This chart was calculated with a bulk density of 65 pounds per cubic foot.

IMPORTANT: Fertilizer application rates can vary from the weights calculated in the above chart. To prevent application miscalculations, make field checks to be sure you are applying fertilizer at the desired rate.

To check the exact number of pounds your fertilizer attachment will actually deliver on a 30 inch row spacing, proceed as follows:

Remove one spout from one of the fertilizer hoppers and attach a container under the opening. Engage the fertilizer attachment and drive forward for 174 feet. Weigh the amount of fertilizer caught in the container and multiply that amount by 100. The result will be the pounds of fertilizer delivered per acre when planting in 30 inch rows.

MACHINE OPERATION

LIQUID FERTILIZER SQUEEZE PUMP APPLICATION RATES

GALLONS PER ACRE

Drive	Driven	30 Inch Row
15	*62	6.9
19	*62	8.8
15	46	9.3
19	46	11.8
15	34	12.6
15	32	13.4
32	*62	14.7
19	34	16.0
19	32	17.0
32	46	19.9
34	46	21.1
46	*62	21.2
15	19	22.5
32	34	26.9
34	32	30.3
19	15	36.2
46	34	38.6
46	32	41.0
32	19	48.1
34	19	51.1
*62	34	52.1

*Optional sprocket.

Above chart for planters equipped with contact drive. See "Tire Pressure" for recommended tire pressures.

This chart was calculated based on a solution weighing ten pounds per gallon.

IMPORTANT: Fertilizer application rates can vary from the above chart. To prevent application miscalculations, make field checks to be sure you are applying fertilizer at the desired rate.

MACHINE OPERATION

LIQUID FERTILIZER PISTON PUMP APPLICATION RATES

GALLONS PER ACRE

Pump Setting	1	2	3	4	5	6	7	8	9	10
6 Row 30	6.9	13.9	20.8	27.7	34.7	41.6	48.5	55.5	62.4	69.3
8 Row 30	5.2	10.4	15.6	20.8	26.0	31.2	36.4	41.6	46.8	52.0

Above chart for planters equipped with contact drive and 50 tooth drive sprocket and 23 tooth driven sprocket. See "Tire Pressure" for recommended tire pressures. Chart is based on average wheel slippage and liquid viscosities.

This chart was calculated based on a solution weighing ten pounds per gallon.

IMPORTANT: Fertilizer application rates can vary from the above chart. To prevent application miscalculations, make field checks to be sure you are applying fertilizer at the desired rate.

ROW UNIT OPERATION

PLANTING DEPTH

Planting depth is maintained by the row unit gauge wheels. To increase or decrease the planting depth, first raise the planter to remove weight from the wheels. Then lift the depth adjustment handle and reposition it forward to decrease depth or rearward to increase planting depth. Adjust all units to the same depth initially. Then lower the planter and check operation and planting depth of all row units. It may be necessary to readjust some rows to obtain uniform operation.

! **WARNING: Never work under the planter while in raised position without using safety lock-ups.**

50677-13

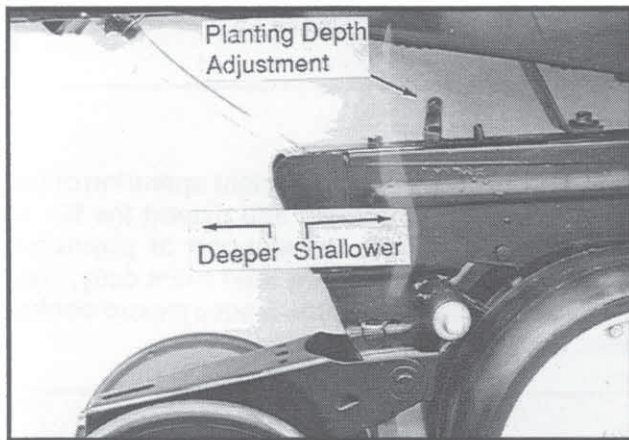

CLOSING WHEEL PRESSURE

After adjusting for planting depth, check the operation of the closing wheels. The closing wheels should gently close the row without sinking in or compacting the soil. To increase spring pressure on the closing wheels, turn the adjustment bolt located at the rear of the closing wheel arm in a clockwise direction. Turning the bolt counterclockwise decreases spring tension.

Adjust all row units to a similar setting. Tension setting can be determined by checking the position of the tension spring through the viewing slot on top of the closing wheel arm. When planting in light soil at average depth (approximately 2") start by setting the dimension between the bolt head and the rear edge of the spring plug at 2 inches. For medium soil at average depth, increase spring tension to obtain 1 1/2" between the bolt head and spring plug. For heavy soil and average planting depths of 2 to 3 inches, set the bolt dimension at approximately 1".

IMPORTANT: In field conditions that require a light soil setting of more than 2", it is recommended that a jam nut be placed on the bolt and tightened against the spring plug. This will prevent bolt loss when operating with minimum spring tension.

50677-13

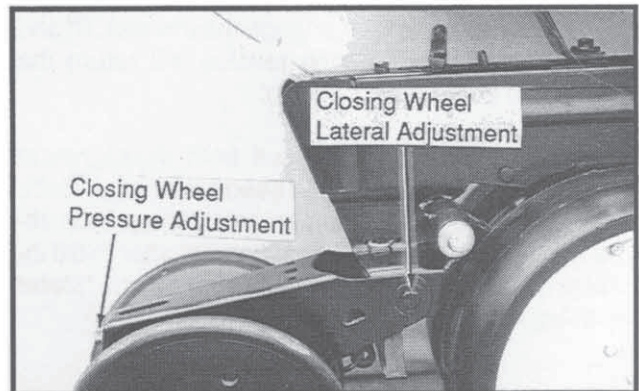

CLOSING WHEEL LATERAL ADJUSTMENT

Slotted holes in the wheel arm stop allow for lateral adjustment of the closing wheel assembly.

Loosen hardware which attaches the closing wheel arm to the wheel arm stop. Shift the closing wheel assembly within the limits of the adjustment slots until the closing wheels are aligned with the row unit. Tighten hardware.

! **WARNING: Raise planter and install cylinder lockups before making closing wheel adjustments.**

ROW UNIT OPERATION

SEED METER DRIVE RELEASE

The seed meter drive is equipped with a clutch release mechanism that allows the drive to be disconnected from the seed metering unit. Disconnecting the drive allows the operator to check granular chemical application rates without dropping seed. It also allows one or more of the rows to be disconnected when finishing fields.

60569-43

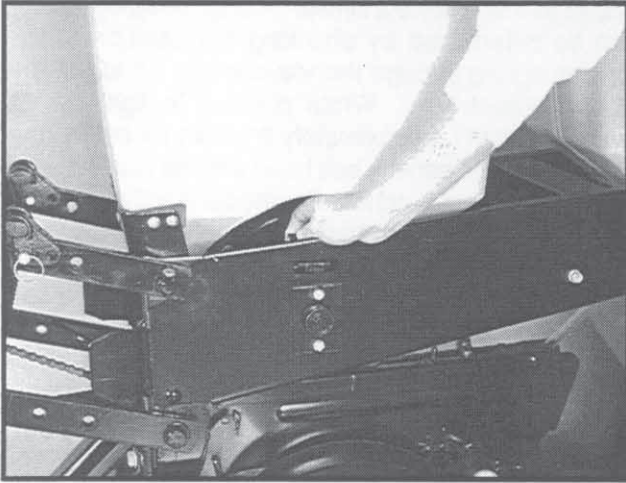

To disengage the drive, lift the release handle and pull outward until the handle locks in the slot in the side of the hopper side panel. To engage the row unit, lift and unlatch the handle. Spring tension will return the mechanism to the drive position.

Erratic seed spacing may result from misalignment between the drive coupler and seed meter input shaft. Misalignment may cause momentary stoppage of brush-type meter seed disc. Check alignment after initial installation. If adjustment is required, refer to "Meter Drive Adjustment" for correct procedure.

FINGER PICKUP CORN METER

Refer to the planting rate charts for recommended seed drive transmission sprocket combinations.

60620-14

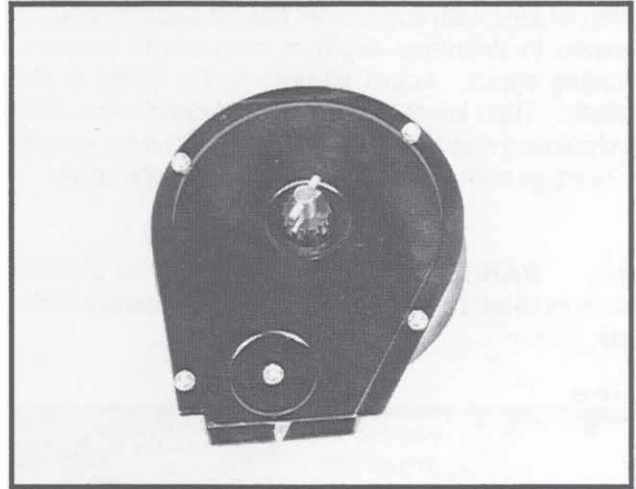

IMPORTANT: To provide efficient operation of the finger pickup corn meters and extend the life of components, sprinkle a teaspoon of powdered graphite over the top of the seed twice daily. The graphite will filter down into the seed pickup mechanism and provide lubrication.

53761-1



See "Finger Pickup Corn Meter Troubleshooting" and "Finger Pickup Corn Meter Inspection/Adjustment" for additional information.

ROW UNIT OPERATION

BRUSH-TYPE SEED METER

60607-40

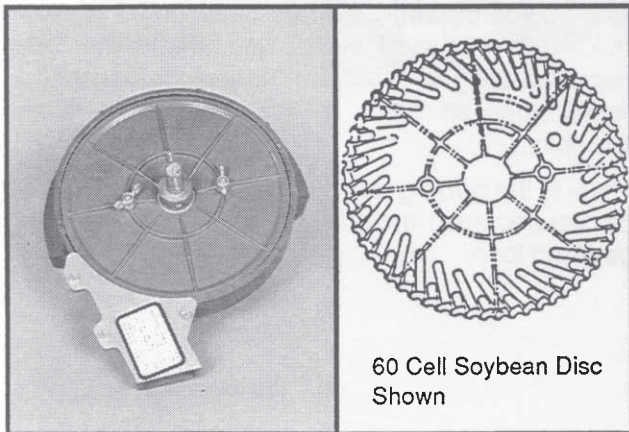

60 Cell Soybean Disc Shown

The following seed discs are available for use with the brush-type seed meter:

Soybean: 60 cells to meter seed sizes from 2200 to 4000 seeds per pound (Black color-coded).

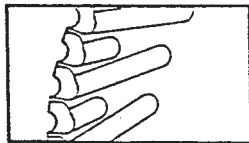

Specialty soybean: 48 cells to meter seed sizes from 1400 to 2200 seeds per pound (Dark blue color-coded).

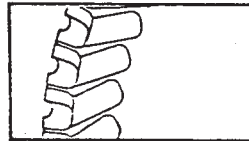

Small milo/grain sorghum: 30 cells to meter seed sizes from 14,000 to 20,000 seeds per pound (Red color-coded).

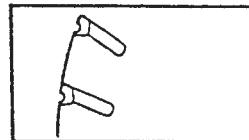

Large milo/grain sorghum: 30 cells to meter seed sizes from 10,000 to 16,000 seeds per pound (Light blue color-coded).

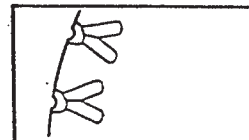

High rate milo/grain sorghum: 60 cells to meter seed sizes from 12,000 to 18,000 seeds per pound (Red color-coded).

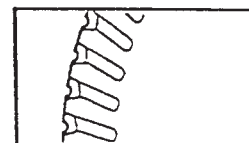

High rate large milo/grain sorghum: 60 cells to meter seed sizes from 10,000 to 14,000 seeds per pound (Yellow color-coded).

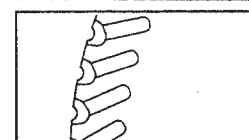

Cotton, acid-delinted: 30 cells to meter seed sizes from 4200 to 5200 seeds per pound (White color-coded).

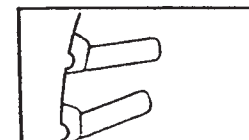

Large cotton, acid-delinted: 36 cells to meter seed sizes 3800 to 4400 seeds per pound (Tan color-coded).

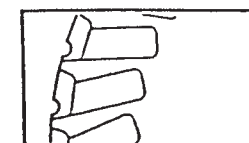

High Rate cotton, acid-delinted: 48 cells to meter seed sizes 4200 to 5200 seeds per pound (Light green color-coded).

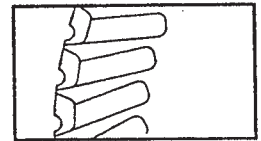

Hill-drop cotton, acid-delinted: 12 cells, 3 to 6 seeds/cell, to meter seed sizes from 4000 to 5200 seeds per pound (Brown color-coded).

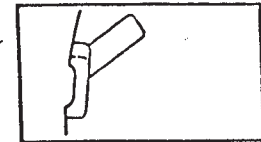

When installing the seed disc onto the meter hub, turn the disc counterclockwise while tightening the two wing nuts that retain the disc. The seed disc should have only slight resistance when rotated counterclockwise after wing nuts are tight.

The brush-type seed meter attaches to the seed hopper in the same manner as the finger pickup corn meter. Secure to bottom of seed hopper with two 5/16" flanged hex nuts. DO NOT OVER TIGHTEN.

Erratic seed spacing may result from misalignment between the drive coupler and seed meter input shaft. Misalignment may cause momentary stoppage of seed disc. Check alignment after initial installation. If adjustment is required, refer to "Meter Drive Adjustment" for correct procedure.

ROW UNIT OPERATION

IMPORTANT: Use powdered graphite or talc with each hopper fill of seed. Additional graphite or talc may be required to retard buildup of seed treatments on meter components. Frequency of monitor seed tube cleaning may be affected due to use of additional graphite or talc.

53761-1

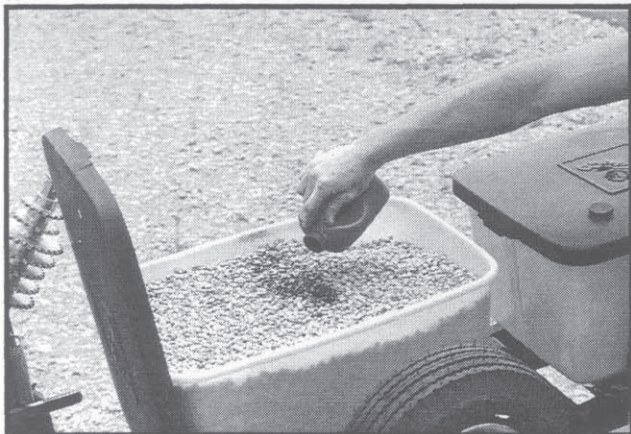

One tablespoon of **powdered graphite** per hopper fill of seed should be added to the seed each time the hopper is filled. This prolongs the life of the seed meter components, reduces buildup of seed treatment on components in the meter and improves seed spacing.

Talc seed lubricant may be used in lieu of graphite to reduce seed treatment buildup on seed disc and meter components and will improve meter performance. Coat seed disc and brushes with talc before installing meter. Fill hopper 1/2 full of seed, add 1/4 cup of talc and mix in thoroughly. Finish filling hopper, add another 1/4 cup of talc and mix thoroughly. Adjust rate of talc use as needed so all seeds are coated, while avoiding a buildup of talc in the bottom of the hopper. Humid conditions and/or small sized seeds with extra seed treatment may require as much as one cup of talc per hopper to prevent seed treatment buildup on seed discs and/or brushes.

CAUTION: Some liquid seed treatments or inoculants may cause buildup on the seed disc or brush. Check frequently for proper population and/or seed delivery when using any liquid seed treatment. All seed treatment should be thoroughly mixed with the seed per the manufacturer's recommendations. Seed treatment dumped on top of the seed after the hopper is filled, and not mixed properly will cause bridging of the seed in the meter, reducing population or stopping the meter from planting. Additional graphite or talc may be required to retard buildup of seed treatments on meter components.

IMPORTANT: Foreign material, such as hulls, stems, etc., may affect seed delivery. Clean seed is required to ensure accurate seed metering from the brush-type seed meter. Seed discs should be removed daily to check for buildup of foreign material, such as hulls, in the seed meter or the brushes.

Refer to the planting rate charts in this manual for recommended seed meter drive transmission sprocket combinations.

ROW UNIT OPERATION

SEED HOPPER

60620-69



The seed hopper has a capacity of 1.6 bushels.

When filling the seed hopper use clean seed and make certain there are no foreign objects in the hopper. **Replace hopper lids after hoppers are filled to prevent the accumulation of dust or dirt in the seed meter which will cause premature wear.** See "Finger Pickup Corn Meter Lubrication" and/or "Brush-Type Seed Meter Lubrication".

Periodically empty the hoppers completely to remove any foreign objects and ensure proper seed meter operation. To empty hopper disengage drive release and hopper latch and lift hopper off the hopper support. See "Meter Drive Release".

GRANULAR CHEMICAL HOPPER

61766-2

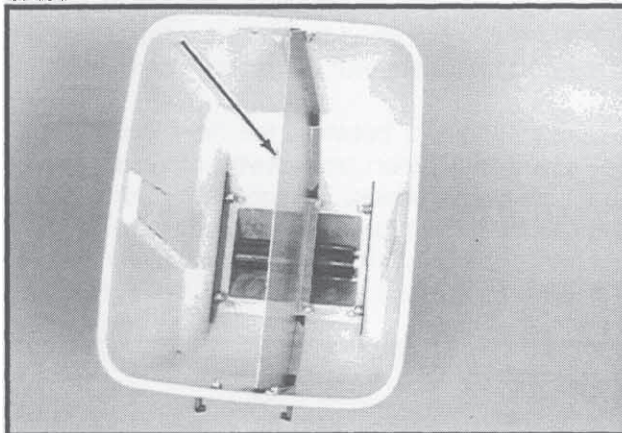

The granular chemical hopper has a 70 pound capacity. With the use of a hopper divider the hopper has two compartments with a 35 pound capacity in each.

Be sure no foreign objects get into the hopper when it is being filled. Replace the hopper lids after filling the hoppers to prevent the accumulation of dirt and moisture buildup.

The metering gate located to the bottom of the hopper regulates the application rate. See "Dry Insecticide and Dry Herbicide Application Rate Charts" in this manual. Calibrate using the chemical manufacturer's instructions.

⚠ DANGER: Agricultural chemicals can be dangerous. Improper selection or use can seriously injure persons, animals, plants, soil or other property. BE SAFE: Select the right chemical for the job. Handle it with care. Follow the instructions on the container label.

The granular chemical clutch drive coupler and meter shaft can be disengaged and engaged by turning the throwout knob located at the rear of the hopper support panel. To engage the drive turn the knob 1/4 turn clockwise. To disengage the drive turn the knob 1/4 turn counterclockwise. Slotted holes in the hopper support panel and clutch housing allow for alignment adjustment between the clutch drive coupler and meter shaft.

54948-18

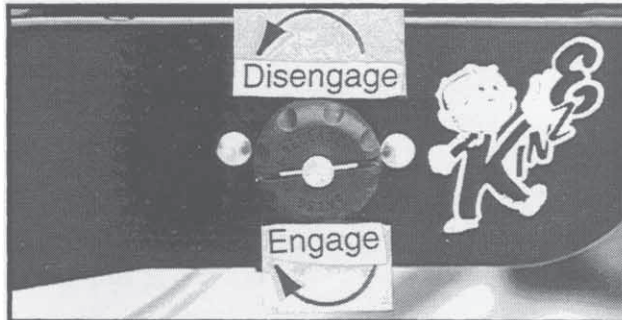

ROW UNIT OPERATION

SEED METER DRIVE ADJUSTMENT

IMPORTANT: The seed meter drive coupler must be properly aligned with the meter input shaft.

Improper alignment between the drive coupler and input shaft of the meter can cause the meter housing to flex as the meter rotates. This continual flexing of the meter housing can cause damage to the housing. Any time the hopper support panel is removed or replaced vertical and horizontal alignment should be checked.

61658-27

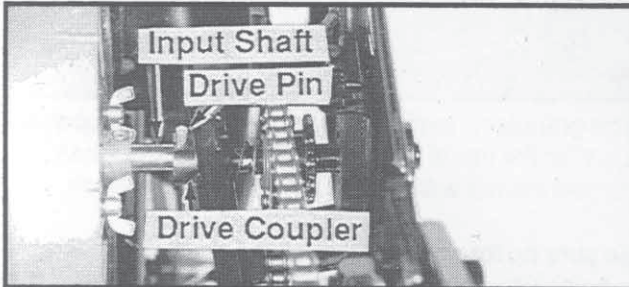

To check alignment:

- Inspect meter input shaft to make sure drive pin is centered.
- Install hopper with meter onto support panel. Latch hopper.
- Rotate meter input shaft so drive pin is vertical.
- Rotate drive clutch so slots in coupler are vertical.
- Engage clutch.
- Clutch coupler should engage meter shaft freely with equal amount of pin extending beyond each side of drive coupler.
- Disengage clutch.
- Rotate both meter shaft and drive clutch to the horizontal position.
- Re-engage clutch.
- Clutch coupler should engage meter shaft freely with equal amount of pin extending beyond each side of drive coupler.

To adjust drive clutch:

- Slightly loosen both 5/16" cap screws.
- Move clutch assembly to correct any misalignment.
- Tighten both 5/16" cap screws.

60569-12

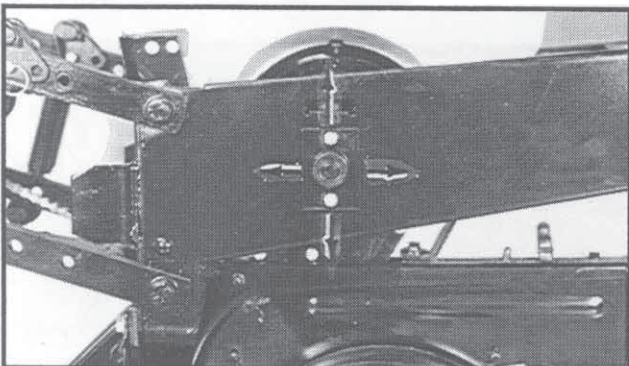

PUSH UNIT LOCKUPS

Push unit lockups are designed to allow the push units to be locked in the raised position.

60569-6

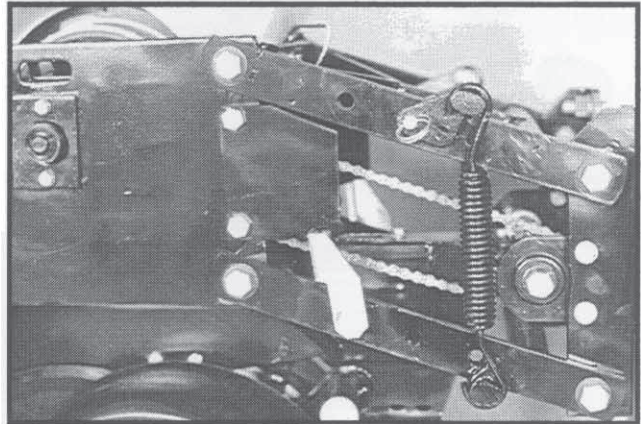

Raised Position

To lock in raised position:

1. With the planter in the raised position, place a wooden (approximately 8") block under the disc opener assembly of each push unit. (Or use other means of raising each push unit.)
2. Lower the planter until the push unit is in the extreme raised position.
3. Rotate both right hand and left hand lockups into place under the push unit stops as shown in the "Raised Position" photo.
4. Raise planter.
5. Remove wooden blocks.

60569-9

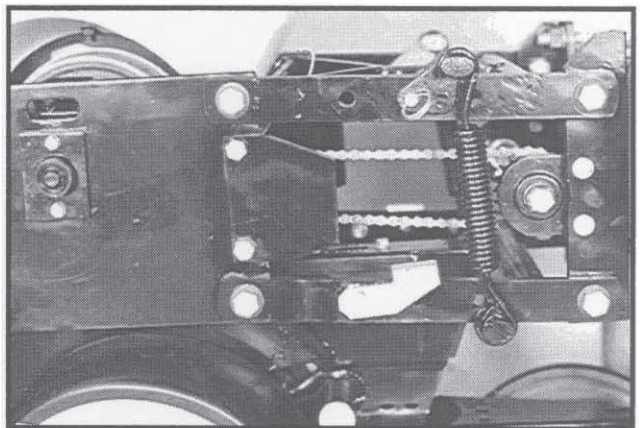

Planting Position

To release lockups:

Reverse of above procedure. At Step 3, rotate lockups out from under the push unit stops as shown in "Planting Position" photo.

⚠ DANGER: Always install all safety lockups or lower planter to the ground before working under or around the machine.

ROW UNIT OPERATION

ROW UNIT CHAIN ROUTING

For proper operation and to minimize wear, the row unit drive chains must be properly tensioned and aligned.

Inspect and replace weak, worn or broken springs and/or idlers and idler bushings.

60569-56

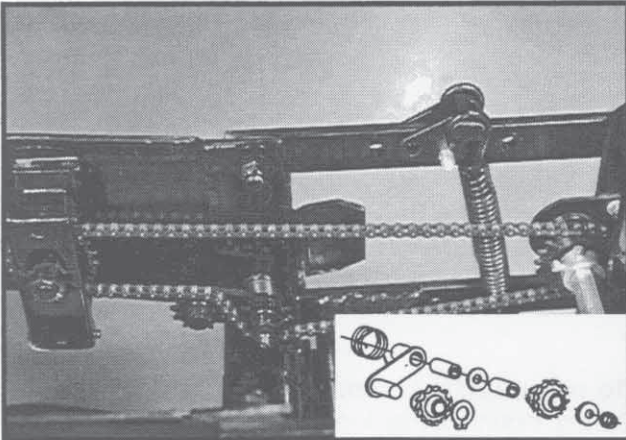

Row Unit Meter Drive

54948-12

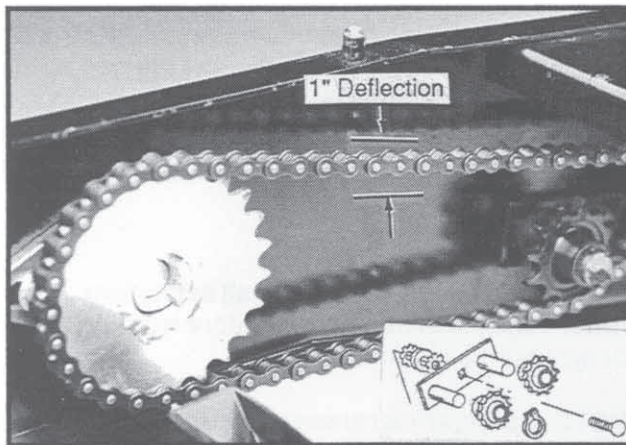

Row Unit Granular Chemical Drive

60569-46

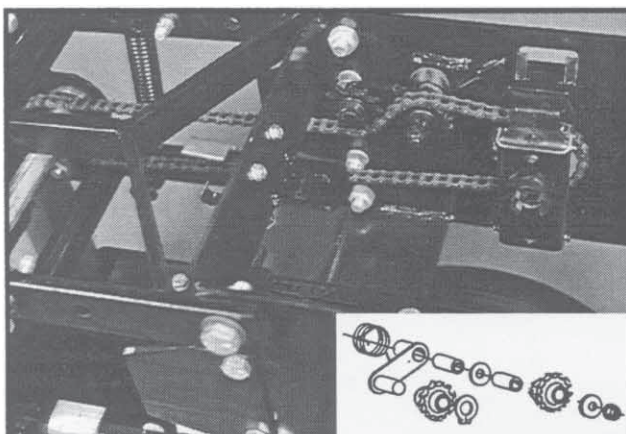

Push Unit Meter Drive

QUICK ADJUSTABLE DOWN FORCE SPRINGS

Quick adjustable down force springs are designed to increase penetration in hard soil and keep the row unit from bouncing in rough field conditions.

Two springs per row, one on the L.H. parallel arms and one on the R.H. parallel arms, are used unless equipped with row unit mounted no till coulters. Four springs per row are used with row unit mounted no till coulters. Two springs per row are used with frame mounted coulters, row unit mounted and frame mounted disc furrowers and row unit mounted bed levelers.

60569-36

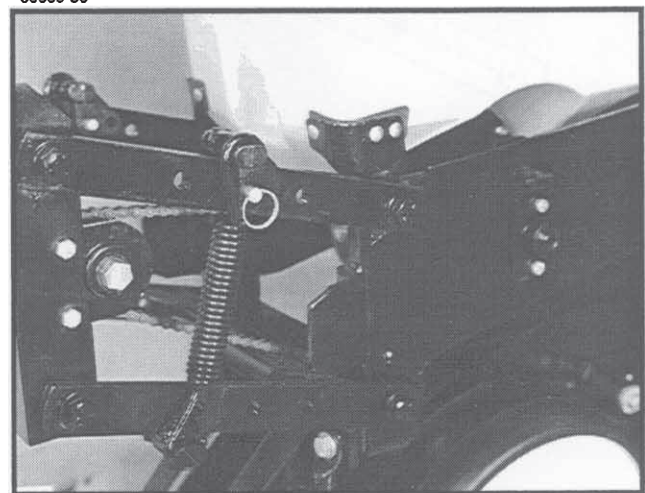

Two Springs Per Row (Dual)

60569-33

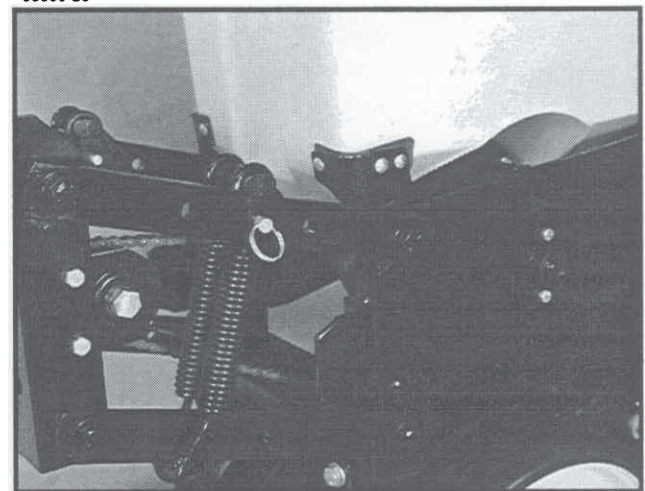

Four Springs Per Row (Quad)
(Used only in conjunction with row unit mounted no till coulters)

ROW UNIT OPERATION

There are four positions for spring tension adjustment. Position one allows for minimum down pressure and position four for maximum down pressure.

L0096

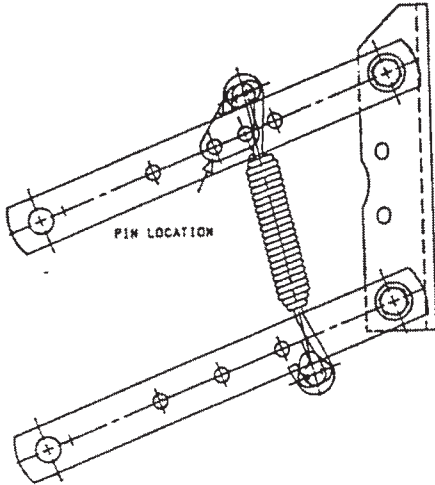

Position 1

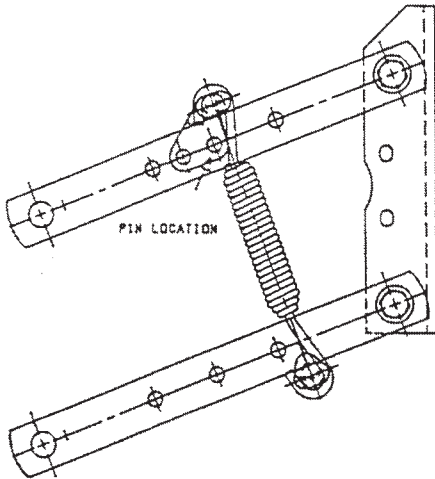

Position 2

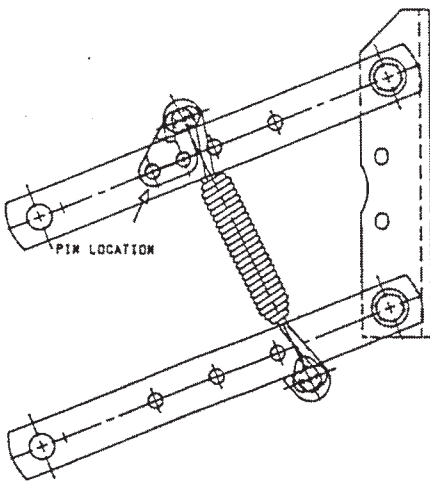

Position 3

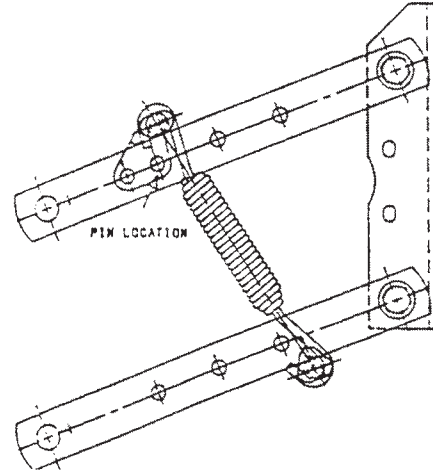

Position 4

To adjust spring tension, raise planter and remove spring mount pin at top of spring. Slide mount to desired position and install pin.

NOTE: It is necessary for the operator to adjust springs according to field conditions. If springs are adjusted for too much down pressure for field conditions, it is possible for the row units to lift the planter to the extent that the drive wheels do not make sufficient contact. Too much down pressure in soft field conditions can cause the row unit to run too deep.

! **DANGER:** Always install safety lockups or lower machine to the ground before working under or around the machine.

NOTE: Springs must always be installed with open side of spring hooks toward seed hopper to prevent binding on spring mount adjustment pin.

ROW UNIT OPERATION

FRAME MOUNTED COULTER

The frame mounted coulters are designed to allow required spring down pressure on the coulters for maximum penetration while exerting less load shock on the row unit.

The frame mounted coulters can be used with or without the depth control bar installed. In most applications, especially in rocky planting conditions, the depth control bar **should not be used**. Use of the depth control bar transfers down force from the coulters to the row unit making less down force available to the coulters blade.

56314-14

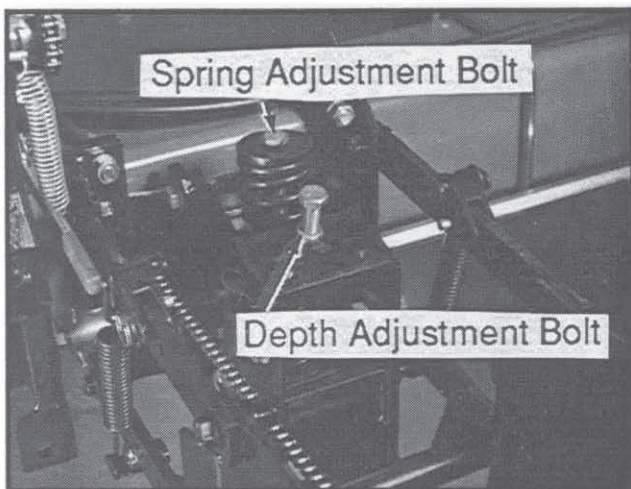

DEPTH ADJUSTMENT (Without Depth Control Bar Installed)

When the depth control bar is not used, operating depth of the coulters blade is determined by adjusting the depth adjustment bolt and positioning of the blade assembly in the fork mount. The depth adjustment bolt will stop downward travel of the coulters arm assembly. One turn of the adjusting bolt will change depth setting approximately 1/4". Initial setting of the depth adjustment bolt should be with approximately 1 3/8" of thread showing. With this setting and the bar height at 21", the coulters depth will be approximately 2" with coulters mounting spindle in top hole. Turn the adjustment bolt clockwise to decrease operating depth. Turn the depth adjustment bolt counterclockwise to increase operating depth.

56314-16

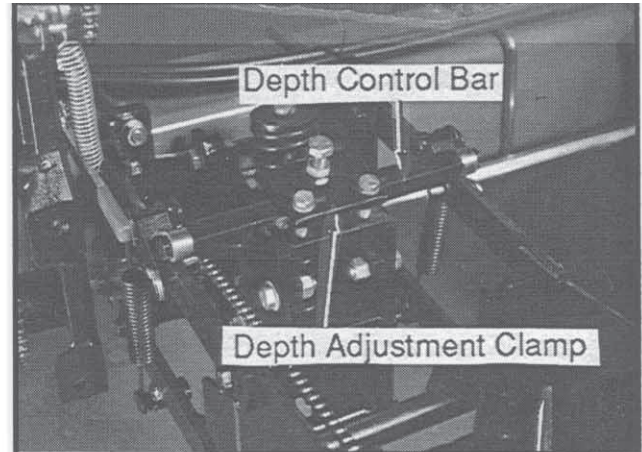

In certain applications it is desirable to use the depth control bar. In uneven terrain, use of the depth control bar allows greater depth control. The up and down movement of the row unit allows the coulters to move up and down at a rate of approximately 1/2 that of the row unit, maintaining a more uniform operating depth. When using the disc furrower attachment, the depth control bar should always be used as operating depth of the coulters is critical for the disc furrowers to operate with minimal gouging.

DEPTH ADJUSTMENT (With Depth Control Bar Installed)

When using the depth control bar, down force springs must be located in the forward position and the depth adjustment bolt used only to attach the depth adjustment clamp to the coulters assembly. Operating depth of the coulters blade is adjusted by positioning the blade assembly in the fork mount. Four blade mounting adjustment positions are available at 1/2" increments. Initial position of the blade assembly should be the top hole. This position will locate the coulters blade approximately 1/4" shallower than the row unit opener blade. In heavy residue it may be desirable to position the blade assembly in the second position to insure that the residue is cut and not forced down into the seed zone. Additional holes are used to compensate for coulters blade wear.

56314-1

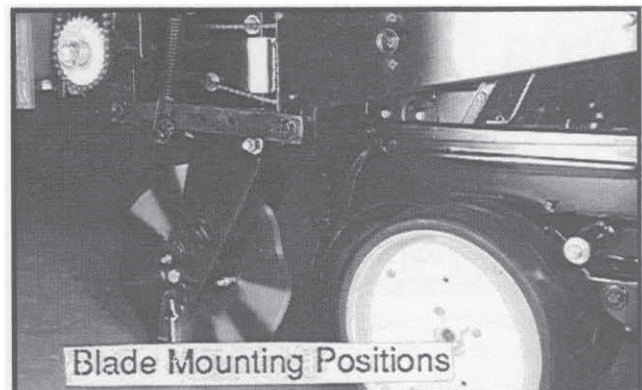

ROW UNIT OPERATION

Down force adjustment is made by tightening or loosening the spring adjustment bolt. With the planter in the raised position, turn the bolt clockwise to increase down force or counterclockwise to decrease down force. Set all rows equally.

Compressed Spring Length (Including Washer)	Pounds Down Pressure With Blade 1/2" Above Maximum Down Position	Pounds Down Pressure With Blade 4" Above Maximum Down Position
13 5/16"	90	230
12 5/16"	190	330
Suggested initial setting.		
11 5/16"	300	430

A5649rev

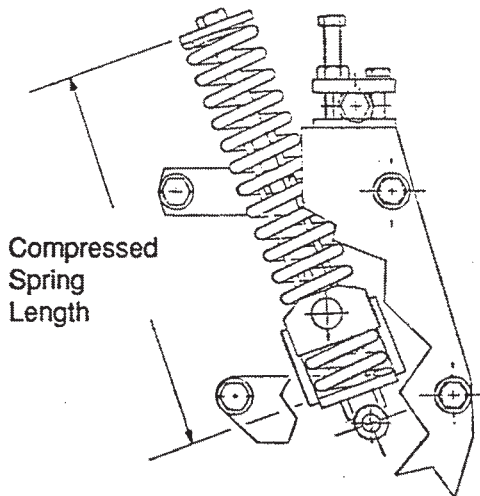

NOTE: Excessive down force may cause increased wear on components.

The coultter blade can be aligned with the row unit disc opener by moving the spacer washers from one side of the coultter blade hub to the other.

56314-12

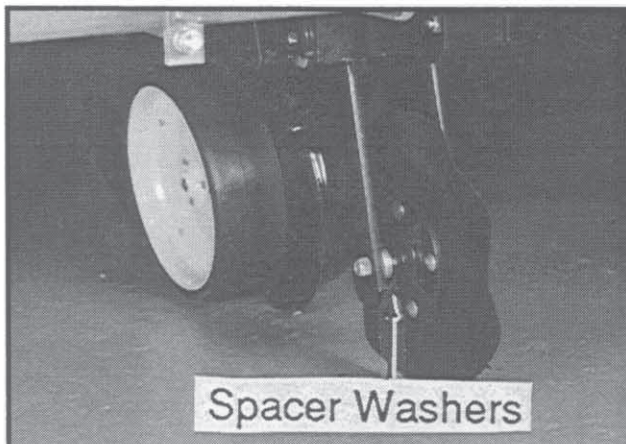

Field adjustment should be made as needed. Operating height of the planter frame will affect operating depth of the frame mounted coultter.

DISC FURROWERS

(For use with Frame Mounted Coultter)

Disc furrowers for use with the frame mounted coultter may be equipped with either 12" solid blades or 12" notched blades.

Disc furrowers are used to clear crop trash, dirt clods and dry soil from in front of the row units for a clean and smooth seed bed. Notched blades are used for heavier trash conditions. The notched blades cut crop residue and move it aside to prevent plugging or pushing the soil.

56314-19

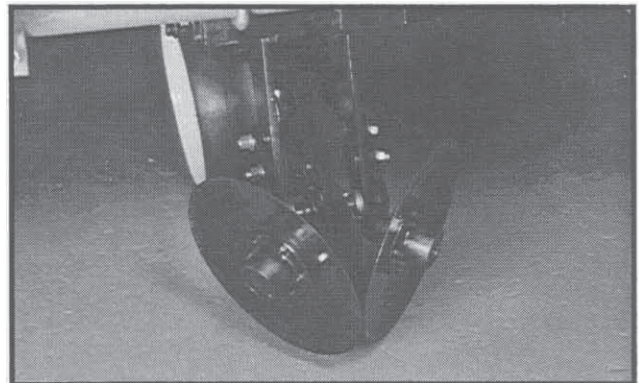

Discs can be adjusted so front edges meet by adding spacer washers between the disc furrower arm and frame mounted coultter fork mount.

Slotted holes in the frame mounted coultter fork mount and in the disc furrower arm allow for vertical and horizontal adjustment. Discs can be adjusted so the front edges meet or one disc can be moved to the rear and the other to the front of the slot so cutting edge of one disc overlaps the edge of the other disc.

56314-17

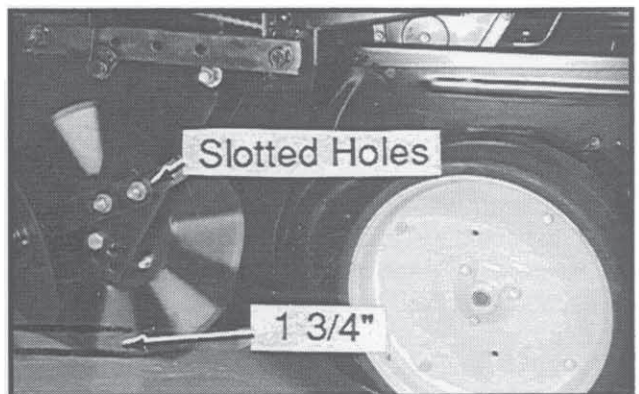

Initial setting for the disc furrowers is 1 3/4" shallower than the coultter blade. Further adjustment may be desired for various applications.

NOTE: The depth control bar should always be used when the frame mounted coultter is equipped with disc furrowers.

ROW UNIT OPERATION

ROW UNIT MOUNTED DISC FURROWER

The row unit mounted disc furrower may be equipped with either 12" solid blades or 12" notched blades.

Disc furrowers are used to clear crop trash, dirt clods and dry soil from in front of the row units for a clean and smooth seed bed. Notched blades are used for heavier trash conditions. The notched blades cut crop residue and move it aside to prevent plugging or pushing the soil.

59386-23

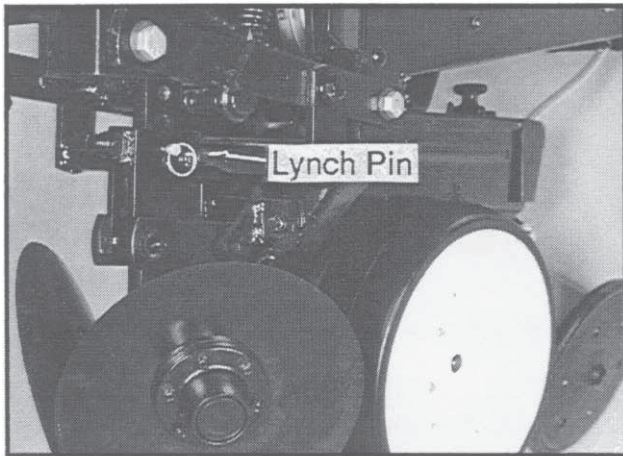

59386-20

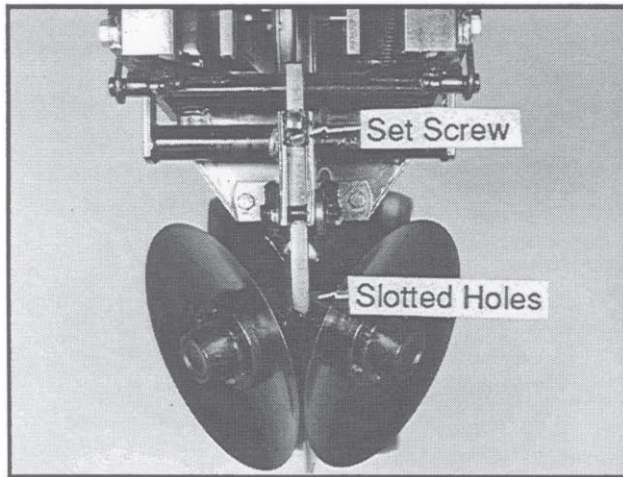

Vertical adjustment in 1/3" increments is possible by removing the lynch pin which secures the vertical support arm and moving the support arm up or down as required. Re-install lynch pin. Finer adjustment can be attained by removing the lynch pin and using the 5/8" x 2 1/4" set screw to clamp the support arm in the required position.

Slotted holes in the support arm where the discs are mounted allow fore and aft adjustment of the discs. Discs can be adjusted so the front edges meet or one disc can be moved to the rear and the other to the front of the slot so cutting edge of one disc overlaps the edge of the other disc. The dust cap must be removed to make these adjustments.

ROW UNIT CHAIN SHIELD

RUB015/RUB016

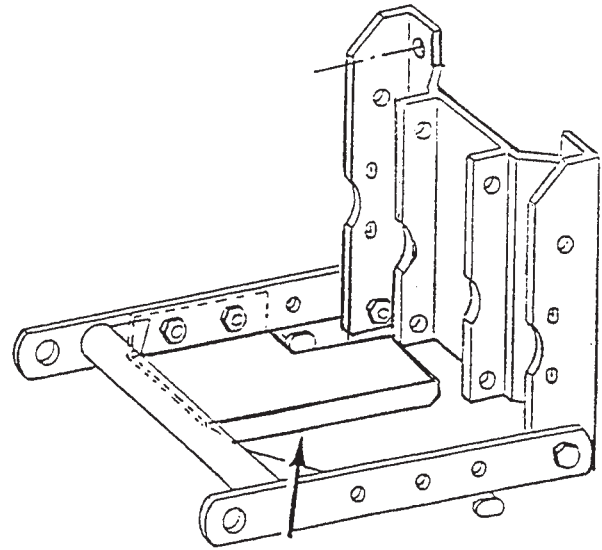

Row unit chain shields are designed for use on conventional row units when row unit mounted no till coulters are used. The shields **CAN NOT BE USED** on inter-plant push units or row units equipped with frame mounted coulters, row unit mounted disc furrowers or row unit mounted bed levelers.

The shield protects the row unit drive chain from damage caused by residue in no till conditions.

ROW UNIT OPERATION

ROW UNIT MOUNTED NO TILL COULTER

60569-42

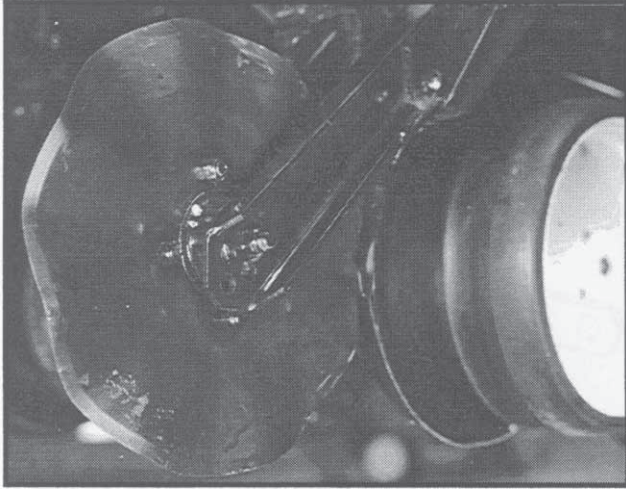

Row unit mounted no till coulters with 1" rippled, 1" fluted or 3/4" fluted blades may be used on plateless row units and interplant push row units. (1" fluted shown)

Four quick adjustable down force springs are required per row when using row unit mounted no till coulters. See "Quick Adjustable Down Force Springs".

For proper operation the coulters blade should be aligned in relation to the row unit double disc openers. The coulters assembly can be adjusted by loosening the four attaching bolts, moving coulters arm to align and tightening the four attaching bolts.

The coulters blade can be adjusted to one of four 1/2" incremental settings in the forked arm. Using the top adjustment hole places the 16" coulters blade approximately 1/4" shallower than the row unit disc opener. Using the second adjustment hole from the top places the coulters blade approximately 1/4" below the row unit disc opener. Using the third adjustment hole places the coulters blade approximately 3/4" below the row unit disc opener and using the bottom adjustment hole places the coulters blade approximately 1 1/4" below the row unit disc opener. Initially the blade should be set in the highest position. As the coulters blade wears or the disc opener blades wear or for various planting conditions the blade may be adjusted to one of the three lower settings.

It is most desirable to run the coulters blade 1/4" shallower than the row unit disc opener so it won't disturb the seed bed below the seed trench opened by the double disc opener.

In heavy residue it may be necessary to run the coulters blade deeper to insure cutting of residue and prevent pushing residue into the seed zone.

Operating depth can be checked by setting the planter down on a level concrete floor and checking the relationship between the coulters blade and row unit opener blade. Make sure the planter is level and coulters is square with the planter frame and aligned with the row unit disc opener.

ROW UNIT OPERATION

ROW UNIT GAUGE WHEEL COVER

60607-37

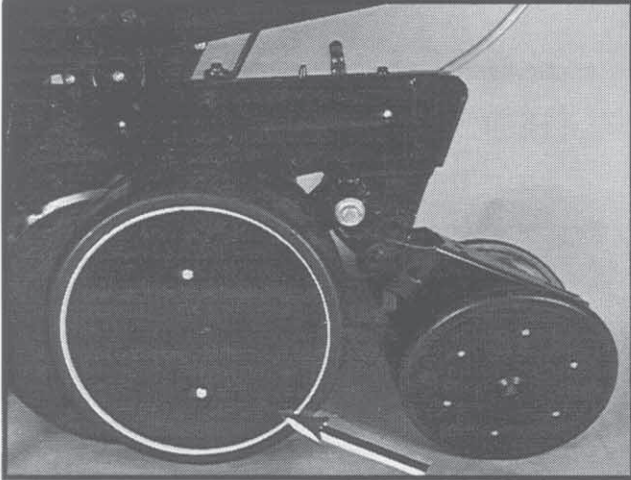

The row unit gauge wheel cover when installed on the gauge wheel next to the transport and/or drive wheels of the planter will aid in protecting the row unit from rock damage.

GRANULAR CHEMICAL RESTRICTOR PLATE

65249-18



The granular chemical restrictor plate is designed for use in the granular chemical hopper when granular chemical application rates below 4 pounds are desired.

IMPORTANT: Check application rate of all rows in the field with the granular chemical you are using and at the speed and population at which you will be planting. See "Checking Granular Chemical Application Rate".

! **DANGER:** Agricultural chemicals can be dangerous. Improper selection or use can seriously injure persons, animals, plants, soil or other property. **BE SAFE:** Select the right chemical for the job. Handle it with care. Follow the instructions on the container label.

SPRING TOOTH INCORPORATOR

The spring tooth incorporator smooths the soil behind the row unit and incorporates granular chemicals. The two mounting chains on each spring tooth incorporator should be adjusted so there is approximately 1/8" slack in the chain when the unit is lowered to planting position.

00138-17

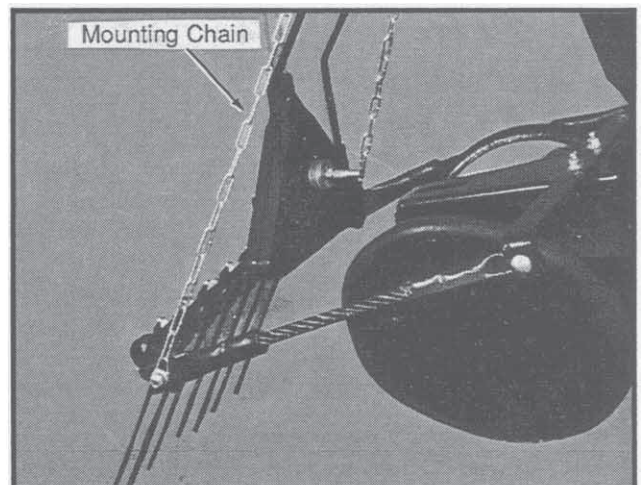

ROW UNIT OPERATION

CLOSING WHEEL TROUBLESHOOTING

Problem	Possible Cause	Solution
Closing wheels leave severe imprint in soil.	Too much closing wheel down pressure.	Adjust closing wheel pressure.
Closing wheels not firming soil around seed.	Insufficient closing wheel down pressure.	Adjust closing wheel pressure.
Closing wheel running on top of seed furrow.	Improper centering.	Align. See "Closing Wheel Lateral Adjustment".

BRUSH-TYPE SEED METER TROUBLESHOOTING

Problem	Possible Cause	Solution
Low count.	Meter RPM's too high.	Reduce planting speed.
	Misalignment between drive clutch and meter.	See "Meter Drive Adjustment".
	Seed sensor not picking up all seeds dropped.	Clean seed tube. Switch meter to different row. If problem stays with same row, replace sensor.
	Lack of lubrication causing seeds not to release from disc properly.	Use graphite or talc as recommended.
Low count at low RPMs and higher count at higher RPMs.	Seed size too large for seed disc being used.	Switch to smaller seed or appropriate seed disc. See "Brush-Type Seed Meter" for proper disc for size of seed being used.
	Seed treatment buildup in meter.	Reduce amount of treatment used and/or thoroughly mix treatment with seed.
	Foreign material lodged in upper brush.	Remove seed disc and remove foreign material from between brush holder and bristles. Clean with compressed air
Low count at higher RPMs and normal count at low RPMs.	Worn upper brush.	Replace.
	Seed disc worn in the agitation groove area.	Replace disc.
High count.	Seed size too small for seed disc.	Switch to larger seed or appropriate seed disc.
	Incorrect seed rate transmission setting.	Reset transmission.
Upper brush layed back.	Seed treatment buildup on brush.	Remove brush. Wash with soap and water. Dry thoroughly before reinstalling.
	Buildup of foreign material at base of brush.	Remove brush holder and brush. Clean with compressed air. Reinstall.

ROW UNIT OPERATION

FINGER PICKUP CORN METER TROUBLESHOOTING

Problem	Possible Cause	Solution
One row not planting seed.	Drive release not engaged. Foreign material in hopper. Seed hopper empty. Pin sheared in drive release sprocket.	Engage drive release mechanism. Clean hopper and finger carrier mechanism. Fill seed hopper Replace pin. Inspect meter for obstructions or defective parts.
	Row unit drive chain off of sprocket or broken.	Check drive chain.
Drive release does not engage properly.	Drive release shaft is not aligned properly with meter drive shaft.	Align drive mechanism. See "Meter Drive Adjustment".
Unit is skipping.	Foreign material or obstruction in meter. Finger holder improperly adjusted. Broken fingers.	Clean out and inspect. Adjust to proper setting. (22 to 25 in. lbs. torque) Replace fingers and/or springs as required.
	Planting too slowly.	Increase planting speed to within recommended range.
Planting too many doubles.	Planting too fast. Loose finger holder. Worn brush in carrier plate.	Stay within recommended speed range. Adjust to specs. (22 to 25 in. lbs. torque) Inspect and replace if necessary.
Over planting.	Worn carrier plate.	Inspect and replace if necessary.
Under planting.	Belt installed backwards. Weak springs. Spring not properly installed. Seed belt catching or dragging. Brush dislodging seed.	Remove and install correctly. Replace. Remove finger holder and correct. Replace belt. Replace brush.
Irregular or incorrect seed spacing.	Driving too fast. Wrong tire pressure. Drive wheels slipping.	Check chart for correct speed. Inflate tires to correct air pressure. Reduce down pressure on row unit down force springs.
	Wrong sprockets.	Check seed rate charts for correct sprocket combinations.
Seed spacing not as indicated in charts.	Wrong tire pressure. Inconsistent seed size. Wrong sprockets. Charts are approximate.	Inflate tires to correct air pressure. Do field check and adjust sprockets accordingly. Check chart for correct sprocket combination. Slight variations due to wear may produce seed spacing variations.
Scattering of seeds.	Planting too fast. Seed tube improperly installed. Seed tube worn or damaged.	Reduce planting speed. Check seed tube installation. Replace seed tube.
Seed tubes and/or openers plugging.	Allowing planter to roll backward when lowering.	Lower planter only when tractor is moving forward.
Inconsistent seed depth.	Rough seed bed. Partially plugged seed tube. Seed tube improperly installed.	Adjust down pressure springs. Reduce planting speed. Inspect and clean. Install properly.

ROW UNIT OPERATION

LUBRICATION

The following pages show the locations of all lubrication points. Proper lubrication of all moving parts will help ensure efficient operation of your KINZE planter and prolong the life of friction producing parts.

⚠ DANGER: Always install safety lockups or lower to the ground before working under the machine.

LUBRICATION SYMBOLS



Lubricate at frequency indicated with an SAE multipurpose type grease.



Lubricate at frequency indicated with a high quality SAE 10 weight oil or a quality spray lubricant.

SEALED BEARINGS

60569-33

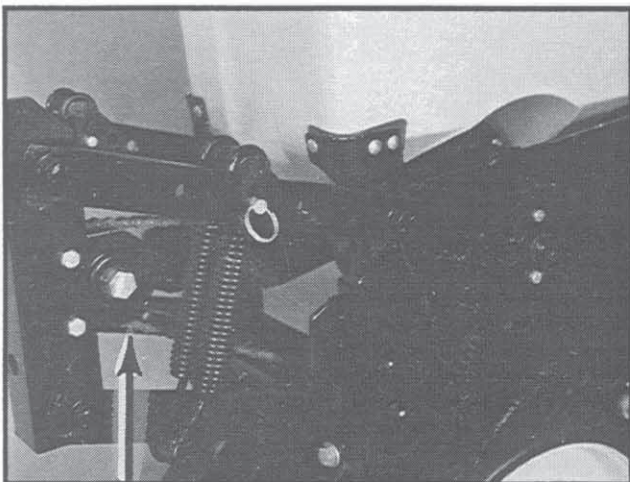

A number of sealed bearings are used on your KINZE planter to provide trouble free operation. These are located in such areas as the drive shaft, row units and transmission bearings. Sealed bearings are lubricated for life, and due to the seals, relubrication is not practical.

CENTER POST

67976-13

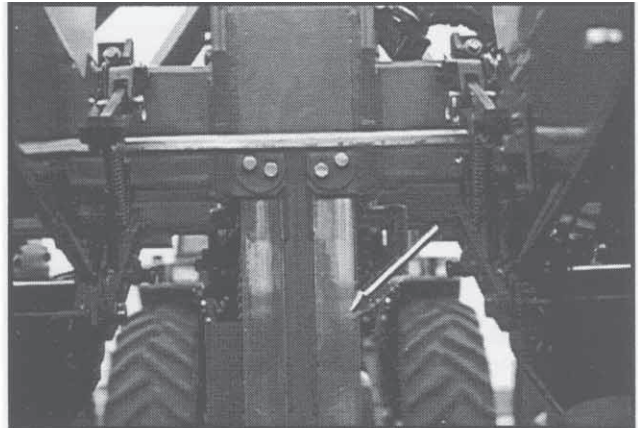

The center post is clad with stainless steel. To prolong service life keep stainless steel surface clean and free of any lubrication.

CENTER POST AND POLY WEAR PAD REQUIRES NO LUBRICATION. ANY OIL OR GREASE WILL ATTRACT DIRT AND ACCELERATE WEAR ON THE CENTER POST AND ON THE POLY WEAR PAD.

DRIVE CHAINS

All transmission and drive chains should be lubricated daily with a high quality SAE 10 weight oil or a quality spray lubricant. Extreme operating conditions such as dirt, temperature or speed may require more frequent lubrication. If a chain becomes stiff, it should be removed, soaked and washed in solvent to loosen and remove dirt from the joints. Then soak the chain in oil so the lubricant can penetrate between the rollers and bushings.

66337-12

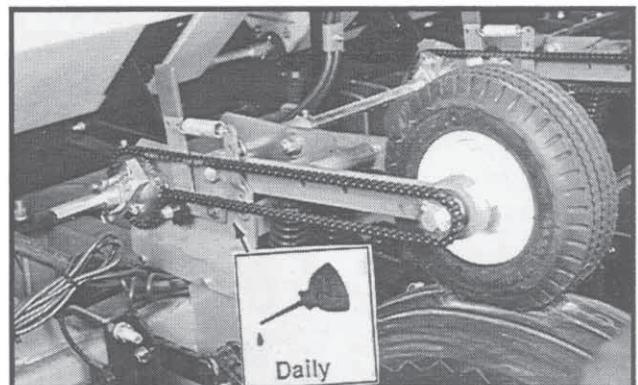

Contact Wheel Drive Chain

LUBRICATION

69797-26

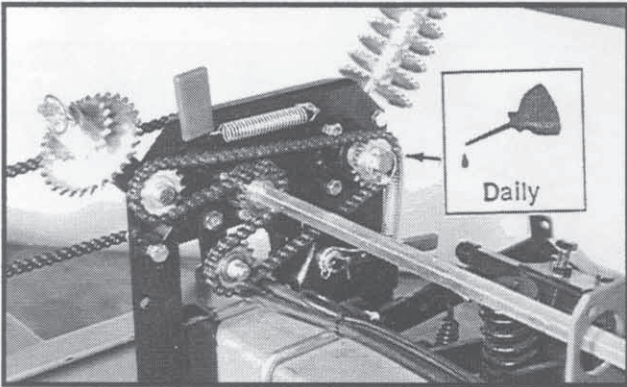

Reverser Plate Drive Chain

69797-7

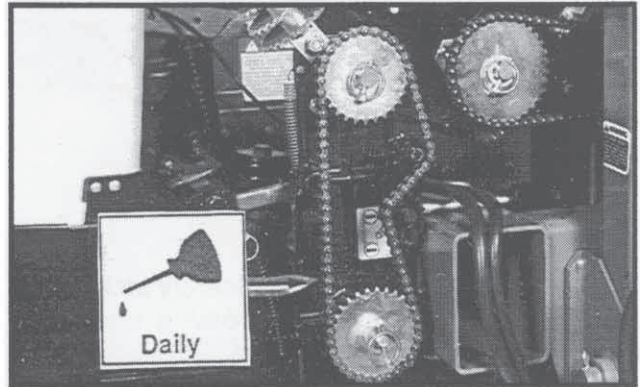

Planter Transmission Drive Chain

60569-56

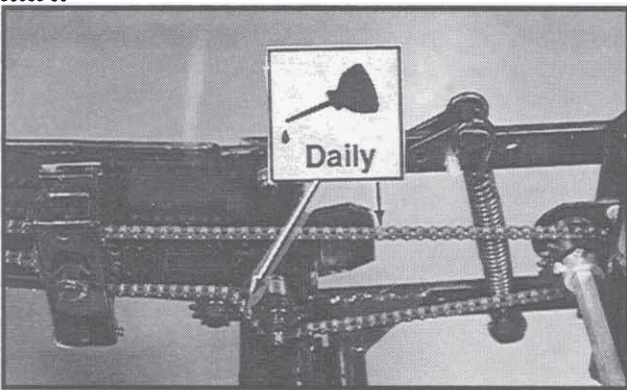

Row Unit Meter Drive Chain

69797-18

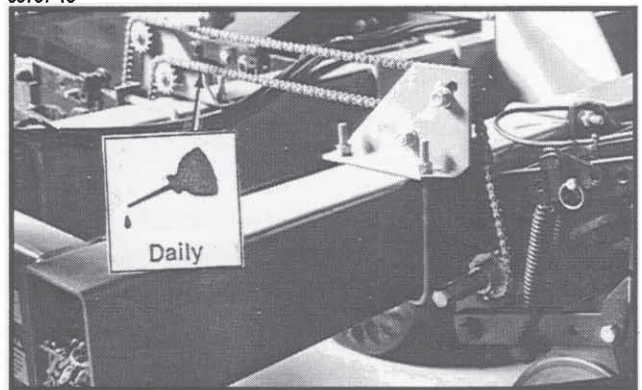

Interplant Drive Chain

54948-12

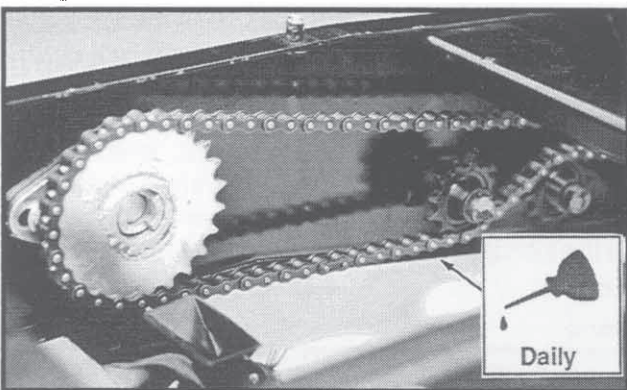

Row Unit Granular Chemical Drive Chain

69797-20

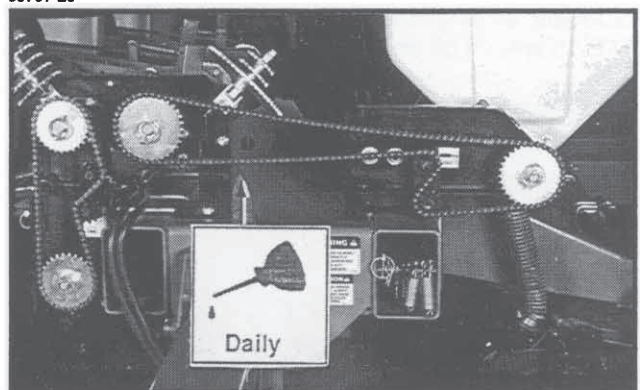

Dry Fertilizer Drive Chain

60569-46

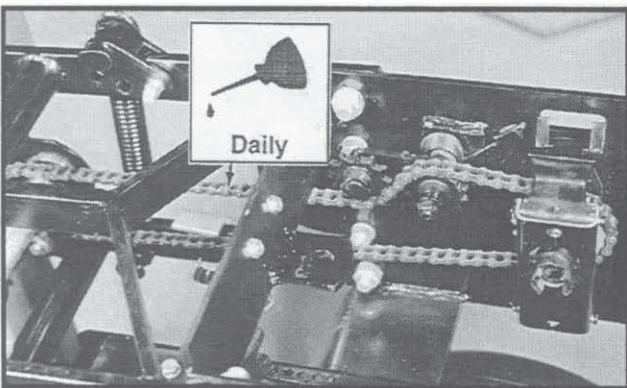

Push Unit Meter Drive Chain

69922-32

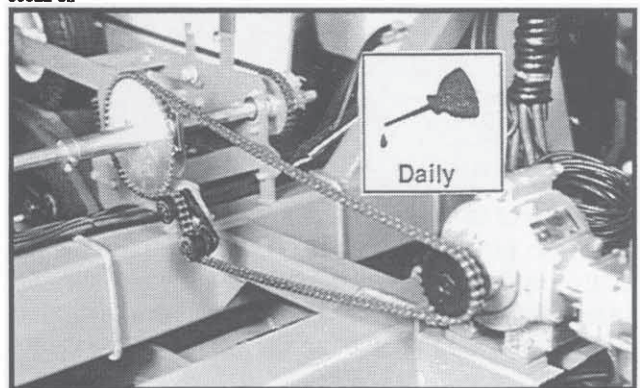

Liquid Fertilizer Drive Chain (Optional Piston Pump)

LUBRICATION

69922-21

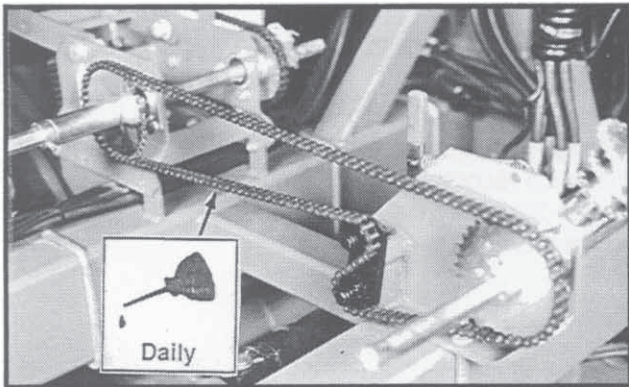

Liquid Fertilizer Drive Chain (Optional Squeeze Pump)

BUSHINGS

Lubricate bushings at the frequency indicated.

Using a wrench, check each bolt for looseness. If bolt is loose, it should be removed and the bushing inspected for cracks and wear. Replace bushing if necessary. **Only hardened flat washers should be used. Replace damaged flat washers with proper part. Torque bolt to 130 ft. lbs.**

56314-8

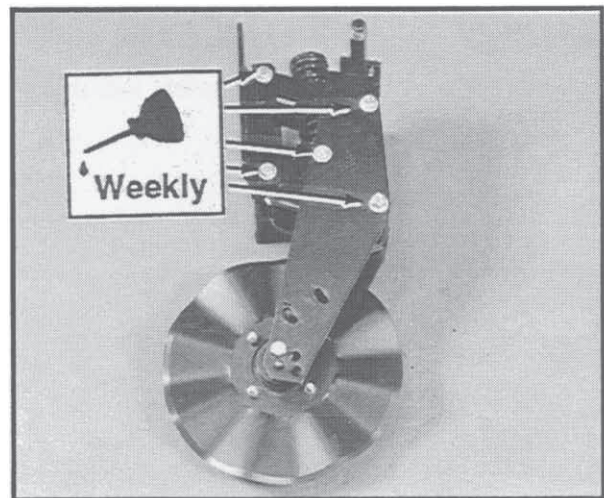

Frame Mounted Coulter Parallel Linkage (10 per row)

Shown not installed on row unit for visual clarity.

59386-43

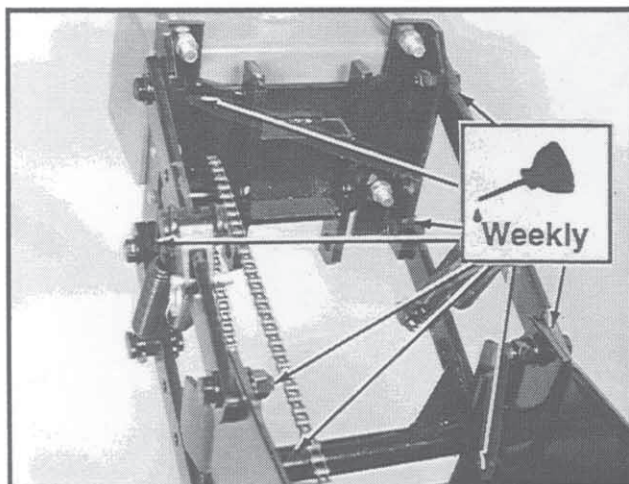

Row Unit and/or Push Unit Parallel Linkage (8 per row)

59386-18

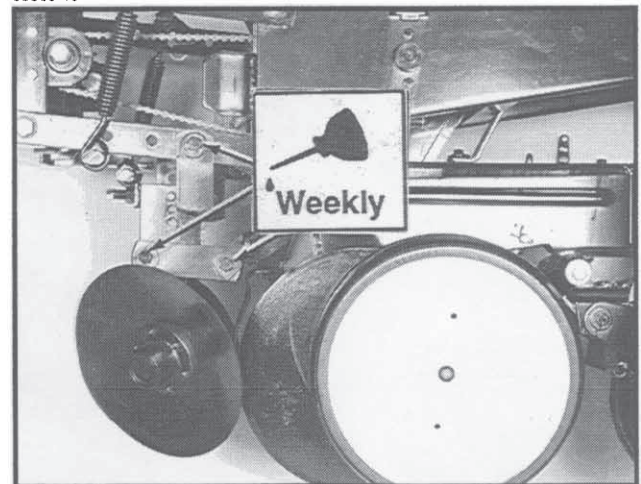

Row Unit Mounted Disc Furrower Parallel Linkage (6 per row)

LUBRICATION

WHEEL BEARINGS

Wheel bearings should be repacked with clean, heavy duty axle grease approximately once a year or at the beginning of each planting season. This applies to all drive wheels, transport wheels and marker hubs. Follow the procedure outlined for wheel bearing replacement with the exception that bearings and bearing cups are reused.

GREASE FITTINGS

Those parts equipped with grease fittings should be lubricated at the frequency indicated with an SAE multipurpose type grease. Be sure to clean the fitting thoroughly before using grease gun. The frequency of lubrication recommended is based on normal operating conditions. Severe or unusual conditions may require more frequent attention.



DANGER: Always install safety lockups or lower to the ground before working under or around the machine.

67999-38

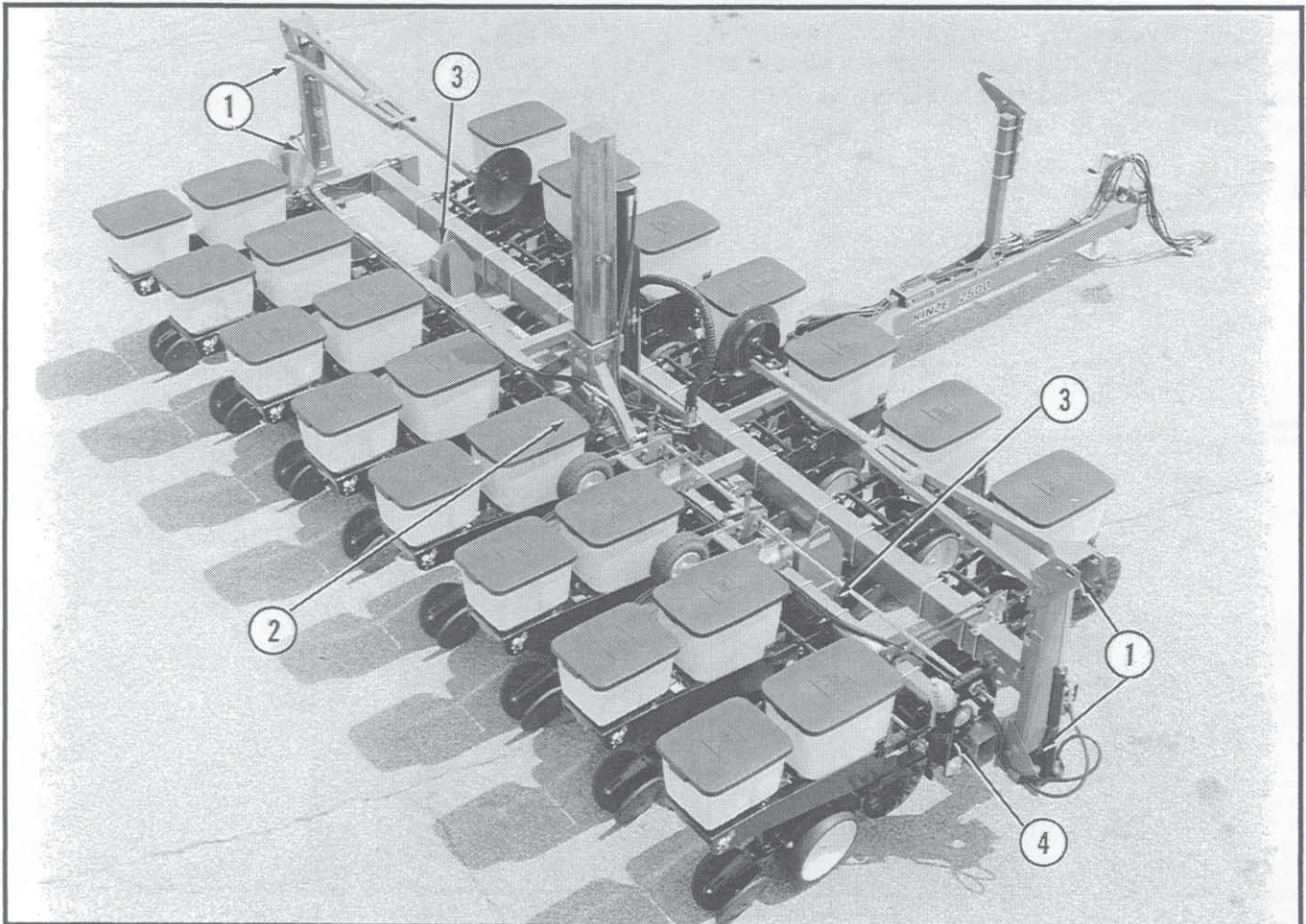

LUBRICATION

Base Machine

69797-38

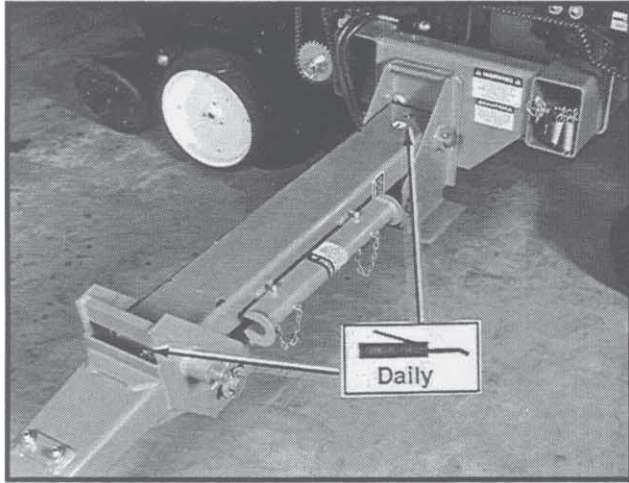

1. Marker Assembly - 2 Zerks Per Assembly

69797-40

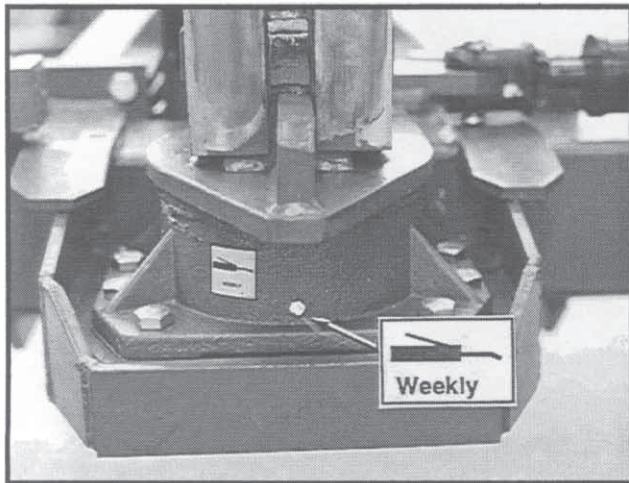

2. Center Pivot - 1 Zerk

67999-22

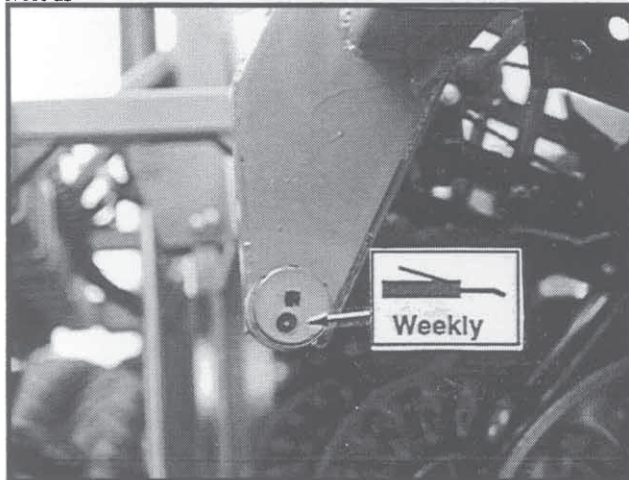

3. Cam Follower - 1 Zerk Per Cam Follower

69797-7

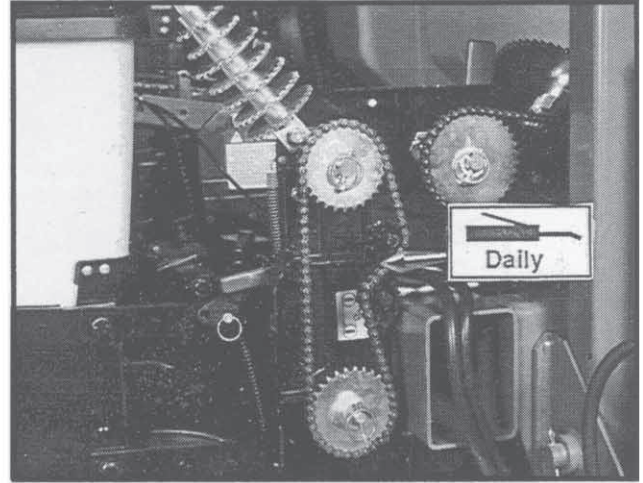

4. Transmission Assembly - 1 Zerk (Idler)

LUBRICATION

Row Unit

50677-13

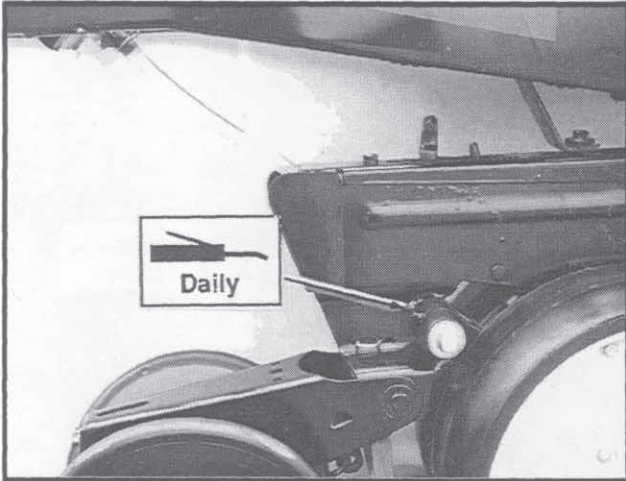

Gauge Wheel Arm - 1 Zerk Per Arm

56673-6

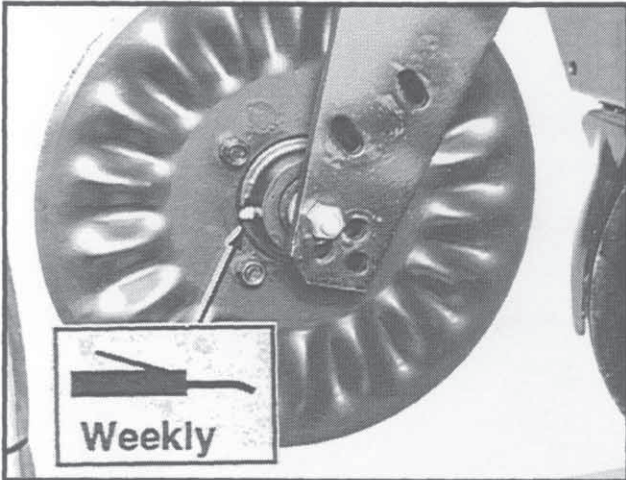

Frame Mounted Coulter Hub - 1 Zerk Per Hub

60569-42

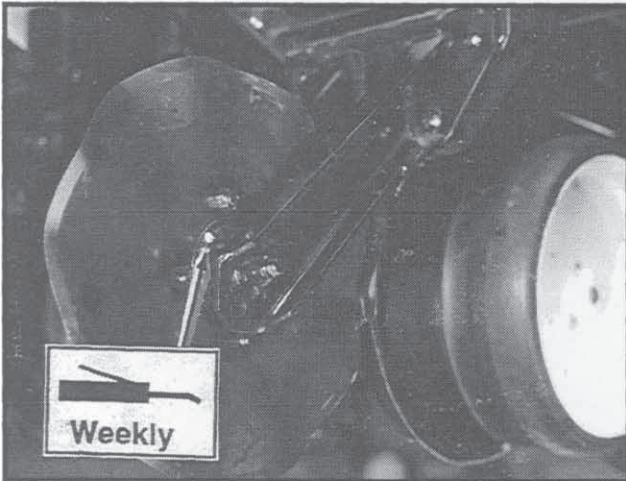

Row Unit Mounted No Till Coulter Hub - 1 Zerk Per Hub

Dry Fertilizer Attachment

61111-28

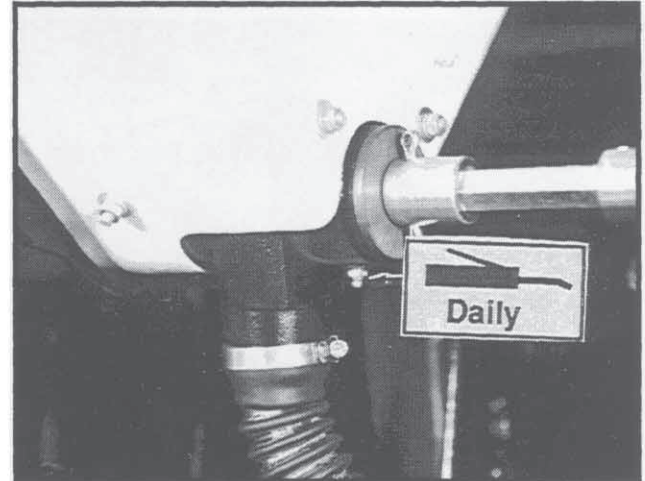

Fertilizer Hopper - 2 Zerks Per Hopper

69797-21

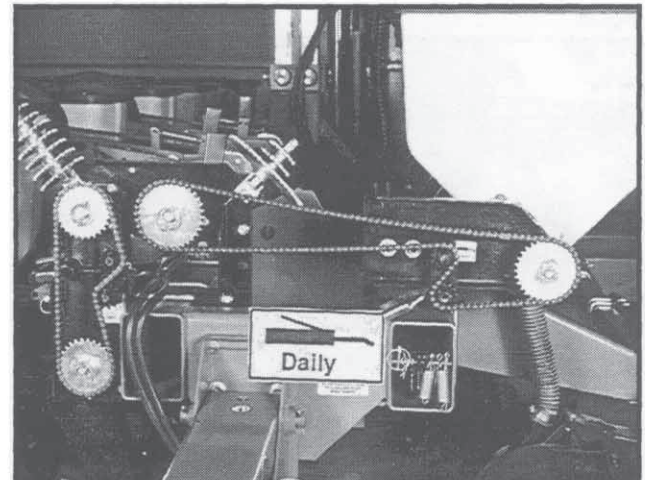

Fertilizer Transmission - 1 Zerk Per Transmission

LUBRICATION

Liquid Fertilizer Attachment

61010-6

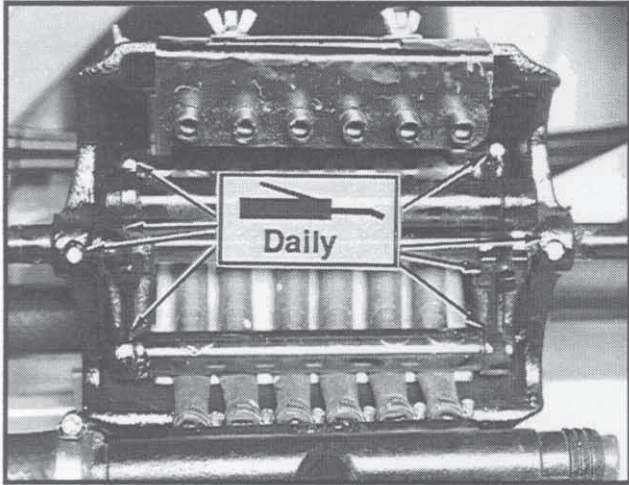

Squeeze Pump - 8 Zerks Per Pump

69922-20

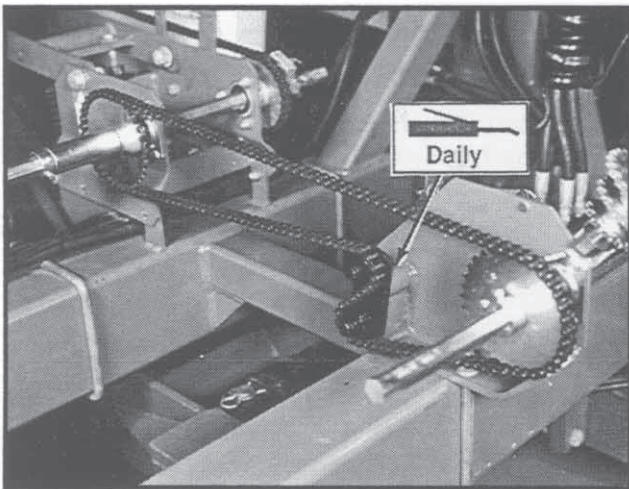

Squeeze Pump Drive Plate - 1 Zerk

Single Disc Fertilizer Opener

60389-58

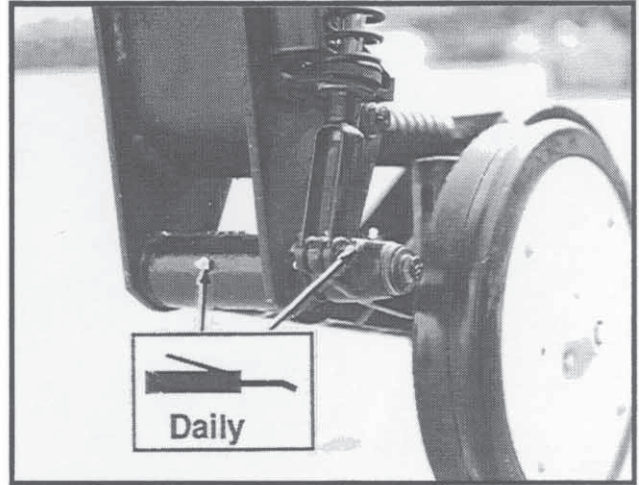

60389-60

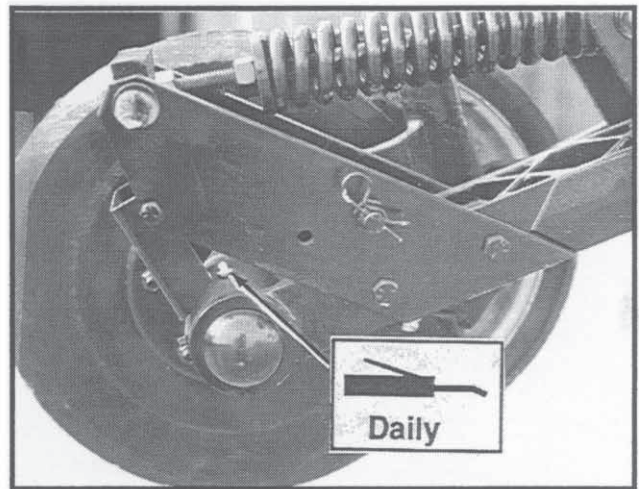

Single Disc Fertilizer Opener - 3 Zerks Per Opener

LUBRICATION

MAINTENANCE

MOUNTING BOLTS AND HARDWARE

Before operating the planter for the first time, check to be sure all nuts and bolts are tight. Check all nuts and bolts again after approximately the first 50 hours of operation and at the beginning of each planting season thereafter.

All bolts used on the KINZE planter are Grade 5 (high strength) unless otherwise noted. Refer to the torque values chart when tightening bolts.

Pivot linkage bushing bolts - 130 Ft. Lbs. (See "Bushings" in the Lubrication Section of this manual.)

NOTE: Over tightening bolts can cause as much damage as under tightening. Tightening a bolt beyond the recommended range can reduce its shock load capacity.

WARNING: Before operating the planter for the first time and periodically thereafter, check to be sure the lug nuts on the transport wheels are tight. This is especially important if the planter is to be transported for a long distance.

TORQUE VALUES CHART - PLATED HARDWARE

Bolt Diameter	Grade 2		Grade 5		Grade 8	
	Coarse	Fine	Coarse	Fine	Coarse	Fine
1/4"	50 In. Lbs.	56 In. Lbs.	76 In. Lbs.	87 In. Lbs.	9 Ft. Lbs.	10 Ft. Lbs.
5/16"	8 Ft. Lbs.	9 Ft. Lbs.	13 Ft. Lbs.	14 Ft. Lbs.	18 Ft. Lbs.	20 Ft. Lbs.
3/8"	15 Ft. Lbs.	17 Ft. Lbs.	23 Ft. Lbs.	26 Ft. Lbs.	33 Ft. Lbs.	37 Ft. Lbs.
7/16"	25 Ft. Lbs.	27 Ft. Lbs.	37 Ft. Lbs.	41 Ft. Lbs.	52 Ft. Lbs.	58 Ft. Lbs.
1/2"	35 Ft. Lbs.	40 Ft. Lbs.	57 Ft. Lbs.	64 Ft. Lbs.	80 Ft. Lbs.	90 Ft. Lbs.
9/16"	50 Ft. Lbs.	60 Ft. Lbs.	80 Ft. Lbs.	90 Ft. Lbs.	115 Ft. Lbs.	130 Ft. Lbs.
5/8"	70 Ft. Lbs.	80 Ft. Lbs.	110 Ft. Lbs.	125 Ft. Lbs.	160 Ft. Lbs.	180 Ft. Lbs.
3/4"	130 Ft. Lbs.	145 Ft. Lbs.	200 Ft. Lbs.	220 Ft. Lbs.	280 Ft. Lbs.	315 Ft. Lbs.
7/8"	125 Ft. Lbs.	140 Ft. Lbs.	320 Ft. Lbs.	350 Ft. Lbs.	450 Ft. Lbs.	500 Ft. Lbs.
1"	190 Ft. Lbs.	205 Ft. Lbs.	480 Ft. Lbs.	530 Ft. Lbs.	675 Ft. Lbs.	750 Ft. Lbs.
1 1/8"	265 Ft. Lbs.	300 Ft. Lbs.	600 Ft. Lbs.	670 Ft. Lbs.	960 Ft. Lbs.	1075 Ft. Lbs.
1 1/4"	375 Ft. Lbs.	415 Ft. Lbs.	840 Ft. Lbs.	930 Ft. Lbs.	1360 Ft. Lbs.	1500 Ft. Lbs.
1 3/8"	490 Ft. Lbs.	560 Ft. Lbs.	1100 Ft. Lbs.	1250 Ft. Lbs.	1780 Ft. Lbs.	2030 Ft. Lbs.
1 1/2"	650 Ft. Lbs.	730 Ft. Lbs.	1450 Ft. Lbs.	1650 Ft. Lbs.	2307 Ft. Lbs.	2670 Ft. Lbs.

NOTE: Unplated bolts should be torqued approximately 1/3 higher than the above values. Bolts having lock nuts should be tightened to approximately 50% of amounts shown in chart. Bolts lubricated prior to installation should be torqued to 70% of value shown on chart.



GRADE 2
No Marks



GRADE 5
3 Marks



GRADE 8
6 Marks

CHAIN TENSION ADJUSTMENT

The drive chains are spring loaded and therefore self-adjusting. The only adjustment needed is to shorten the chain if wear stretches the chain and reduces spring tension. The pivot point of these idlers should be checked periodically to ensure they will rotate freely.

Additional chain links can be found in the storage area inside the front planter frame.

69797-23

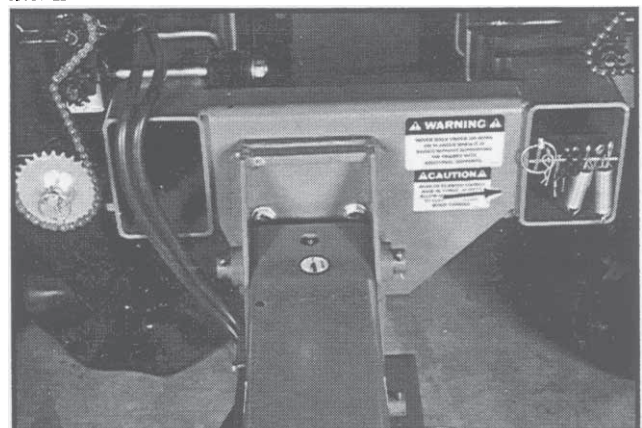

MAINTENANCE

FINGER PICKUP CORN METER INSPECTION/ADJUSTMENT

To inspect or service the finger pickup corn meter, remove the meter from the seed hopper by removing the two nuts which secure the mechanism to the hopper. Remove the baffle from the meter assembly by removing three cap screws. This will permit access to the finger pickup.

60620-8

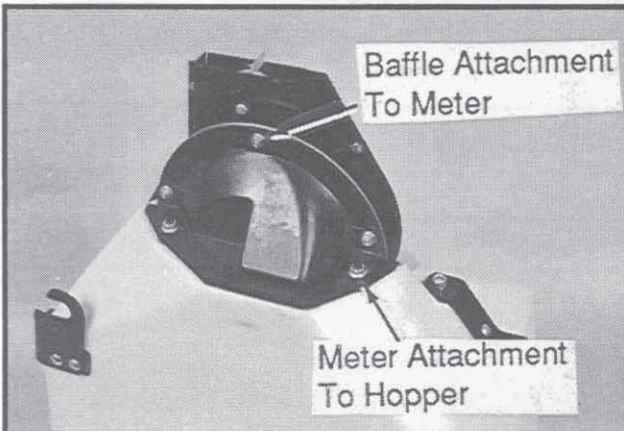

Rotate the seed meter drive by hand to ensure that the springs are holding the tabs of the fingers against the carrier plate where indicated in the photo and that the fingers are being raised in the correct area.

60620-17

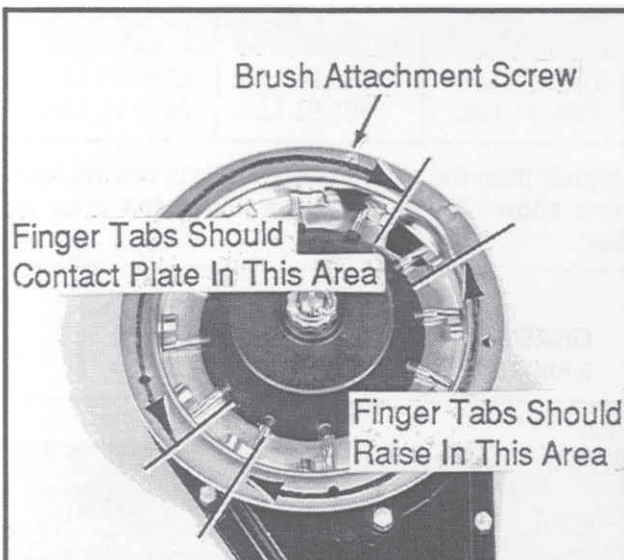

A build-up of debris or chaff may prevent proper finger operation and will require disassembly and cleaning of the corn meter as follows:

1. Remove cotter pin, cage nut and adjusting nut from drive shaft.
2. Carefully lift finger holder, along with fingers and cam, off of the shaft and clean.

60620-3

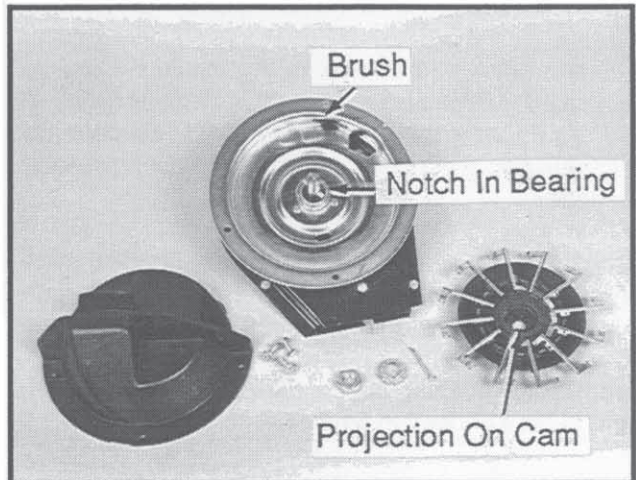

3. Check brush for wear and replace if necessary or following every 100 acres per row of operation.

EXAMPLE: Approximately 600 acres of corn on a 6 row machine or 800 acres on an 8 row machine.

NOTE: It is not necessary to remove finger holder to remove brush.

4. To replace fingers or springs, remove springs from fingers and remove finger from holder by lifting it out of the friction fit slot. Under average conditions, life expectancy of these parts should be 600-900 acres per row of operation.

5. After cleaning and/or replacing defective parts, reassemble the meter in the reverse order. When replacing fingers, make sure the open end of the spring loop is toward the inside of the finger holder.

60620-22

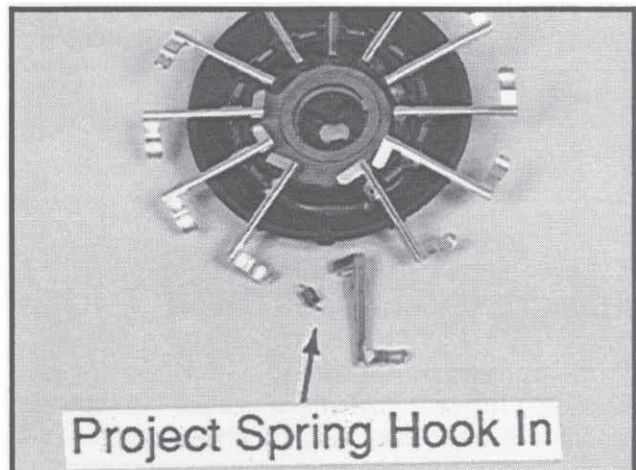

6. Make sure fingers are installed in holder so that holder will be positioned flush with the carrier plate when assembled. A projection on the cam is designed to align with a mating notch in the bearing housing to ensure proper operation when assembled.

MAINTENANCE

50725-4

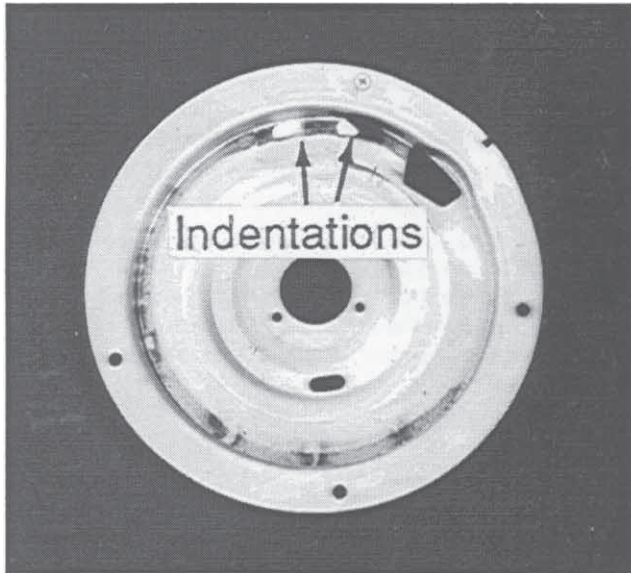

Photo shows worn plate

7. Before installing the finger holder on the carrier plate, check the indentations on the carrier plate for wear. Excessive wear of the carrier plate at the indentations will cause over planting especially when using small sizes of seed corn.

Inspect the carrier plate annually. Under average conditions, the life expectancy of the carrier plate should be 250-300 acres per row of operation.

8. With finger holder flush against the carrier, install adjusting nut until it contacts the finger holder with a slight resistance. Continue to turn the nut an additional 1/3 turn or torque to 22 to 25 inch pounds of rolling torque on input shaft.

9. Turn finger holder by hand to make sure it is positioned firmly against the carrier, but is not over tightened and can be rotated with moderate force.

10. Install cage nut and cotter pin and reinstall housing.

NOTE: Check tightness of adjusting nut on each unit after first day of use and periodically thereafter.

To inspect or replace the seed belt, remove the four cap screws around the edge of the housing cover and the nut from the belt idler mounting bolt.

60620-13

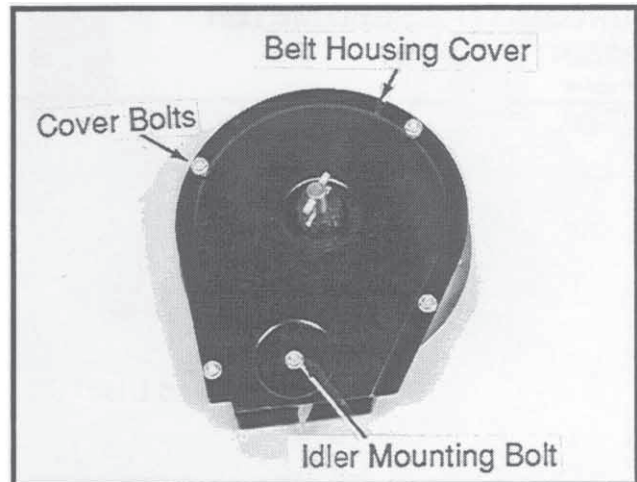

60887-97

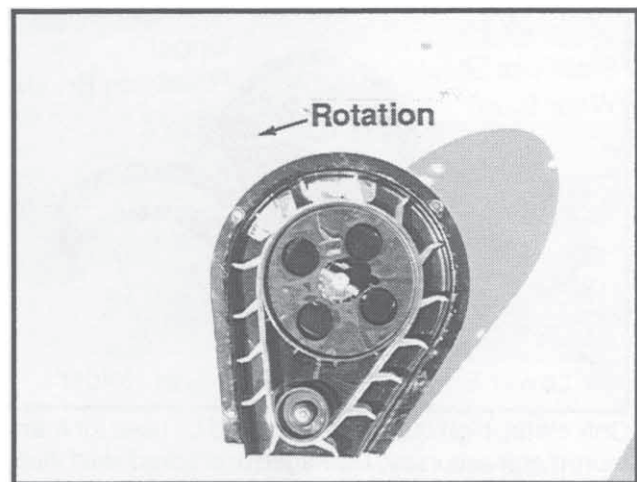

If the belt is being replaced, make sure it is reinstalled to correctly orient the paddles as shown. A diagram molded into the drive sprocket also illustrates the correct orientation.

CAUTION: Do not over tighten hardware.

FINGER PICKUP CORN METER CLEANING

1. Disassemble meter.
2. Blow out any foreign material present in the meter mechanism.
3. Wash in mild soap and water. **DO NOT USE GASOLINE, KEROSENE OR ANY OTHER PETROLEUM BASED PRODUCT.**
4. Dry thoroughly.
5. Coat lightly with a rust inhibitor.
6. Store in a dry place.

MAINTENANCE

BRUSH-TYPE SEED METER MAINTENANCE

60607-10

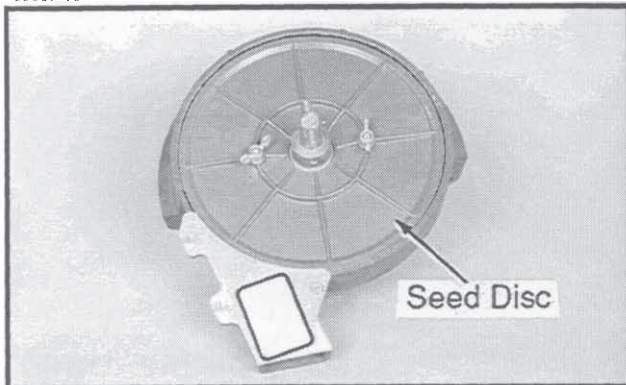

60607-3

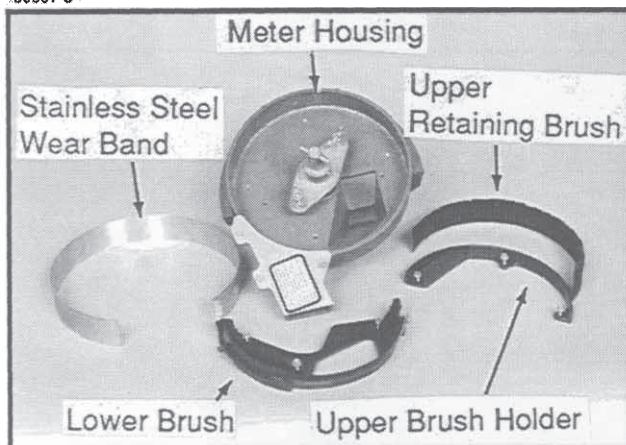

Only clean, high quality seed should be used for maximum meter accuracy. Damaged or cracked seed, hulls or foreign materials may become lodged in the upper seed retaining brush and greatly reduce meter accuracy. It is suggested that the seed disc be removed daily, inspected and cleaned. Check for buildup of foreign material on the seed disc, particularly in the seed loading slots. Clean the disc by washing it with soap and water. Check for cracked seed, hulls, etc. lodged between the brush holder and stainless steel wear band which can greatly reduce the accuracy of the meter because the retaining brush will not be able to retain the seed in the seed disc pocket. Use compressed air to clean the brush areas of the meter housing.

60607-8

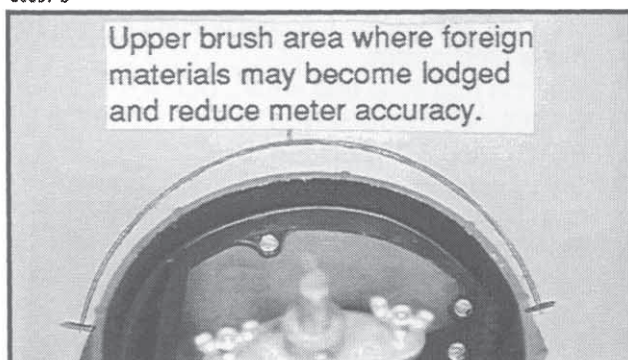

Estimated life expectancies of the upper and lower brushes, stainless steel wear strip and seed disc are 200-300 acres per row.

NOTE: Replace hopper lids after hoppers are filled to prevent accumulation of dust or dirt in the seed meter which will cause premature wear.

Cleaning brush-type seed meter for storage:

1. Remove meter from seed hopper by removing the two nuts which secure the meter to the hopper.
2. Remove seed disc and wash with soap and water and dry thoroughly.
3. Remove upper retaining brush by removing the three hex head screws from the brush holder and removing brush holder and retaining brush.
4. Remove the three hex head screws from the lower brush and remove lower brush and stainless steel wear band.
5. Wash all parts and meter housing with soap and water and dry thoroughly.
6. Inspect all parts for wear and replace worn parts.
7. Reassemble meter except for seed disc. **Meter should be stored without seed disc installed.**

Installation Of Upper Retaining Brush

Position retaining brush into inner perimeter of seed retention area. Make sure the base of the brush is tight against the bottom of the meter housing. Install brush holder and three hex head screws and tighten.

Seed Disc Wear

HD112690

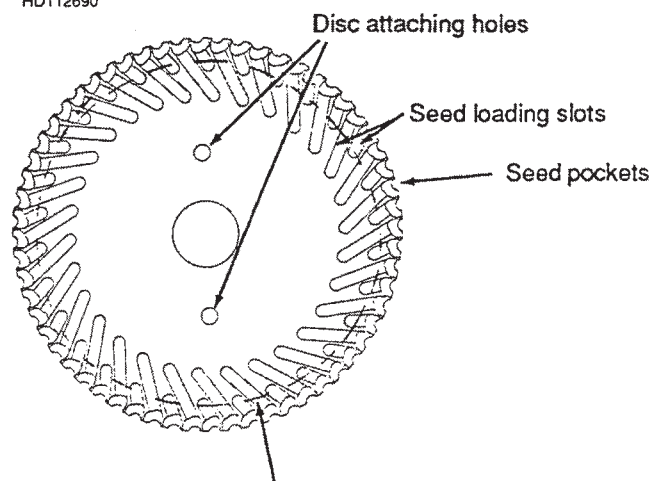

Most wear on the seed disc will be found in the area between the seed loading slots. If wear in this area is greater than .075" and accuracy starts to drop off at higher meter RPMs, the seed disc should be replaced. Wear will affect planting accuracy at high RPMs. To measure for wear lay a straight edge across the surface of the disc and measure the gap between the disc and the straight edge.

MAINTENANCE

Stainless Steel Wear Band

60607-38



The purpose of the stainless steel wear band is to protect the meter housing from wear. The band is .030" thick and should be replaced when approximately .020" of wear is found in the primary area of wear. If the wear band is allowed to wear through or if the meter is used without the wear band in place, damage to the meter housing may occur.

Upper Retaining Brush

60607-21

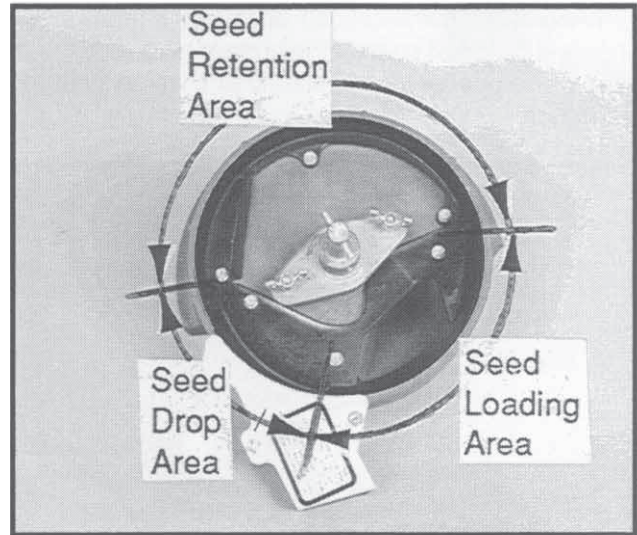

The upper retaining brush holds seed in the disc seed pocket in the seed retention area.

The retaining brush must apply enough pressure against the seed in the disc seed pocket as the disc rotates through the seed retention area to prevent the seed from dropping out of the disc pocket. A damaged spot, excessive wear on the brush or foreign material lodged in the brush may greatly reduce meter performance.

The retaining brush should be replaced at approximately 200-300 acres per row of use or sooner if damage or excessive wear is found.

MAINTENANCE

GAUGE WHEEL ADJUSTMENT

To prevent an accumulation of dirt or trash, gauge wheels should just contact the opener blades. Gauge wheels and opener blades should turn with only slight resistance.

50677-13

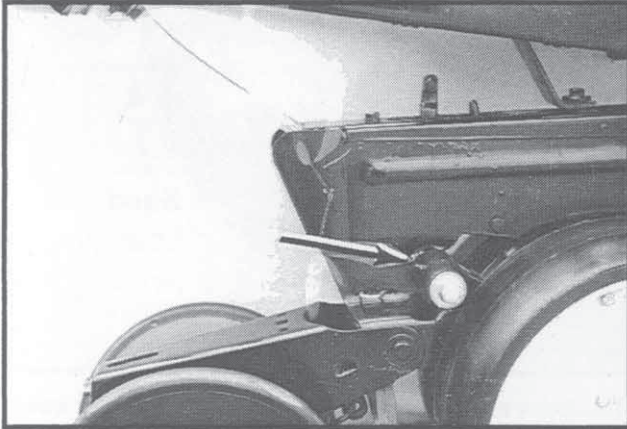

To adjust clearance between gauge wheels and opener blades, add or remove 1 1/64" spacer washers between the shank and gauge wheel arm. Store remaining spacer washers between gauge wheel arm and flat washer on outer side of gauge wheel arm.

NOTE: It may be desirable to space gauge wheel further from blade when operating in sticky soils.

15" SEED OPENER DISC/BEARING ASSEMBLY

60569-48

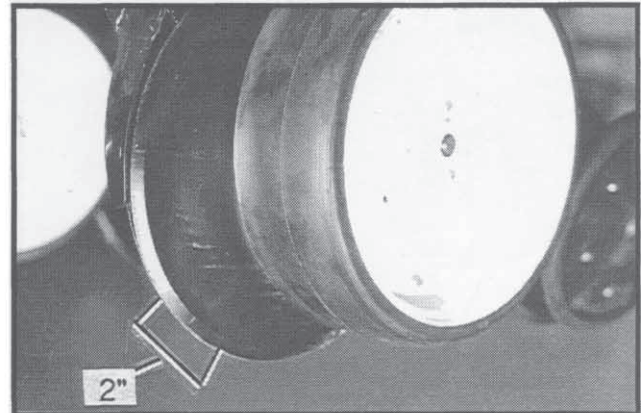

If 2" of blade contact cannot be maintained after removing spacer washers, the blade should be replaced.

To replace disc/bearing assembly:

1. Remove gauge wheel.
2. Remove bearing dust cap.
3. Remove jam nut and washer from outside of disc/bearing assembly.

NOTE: Left hand side of opener uses a left hand threaded nut. **DO NOT OVER TIGHTEN.** Damage to mounting spindle will require replacement of row unit shank assembly.

4. Remove disc/bearing assembly. The spacer bushings between the shank and disc are used to maintain the blade to blade contact at 2".
5. After installing new disc/bearing assembly, install washer and jam nut to secure disc/bearing assembly. Torque 5/8"-11 Grade 2 nut to value shown in Torque Values Chart.
6. Replace bearing dust cap.

It may be necessary to replace only the bearing if the bearing sounds rough when the disc is rotated.

To replace bearing:

1. Remove gauge wheel, bearing cap, jam nut, washer and disc/bearing assembly.
2. Remove 1/4" rivets from bearing housing to expose bearing.
3. After installing new bearing, install three evenly spaced 1/4" bolts into three of the six holes in the bearing housing to hold the bearing and bearing housing in place. Install rivets in the other three holes. Remove 1/4" bolts and install rivets in those three holes..
4. Reinstall disc/bearing assembly, washer and jam nut. Torque 5/8"-11 Grade 2 nut to value shown in Torque Values Chart at end of this section.
5. Replace bearing dust cap.

MAINTENANCE

SEED TUBE GUARD

The seed tube guard protects the seed tube and acts as the inner scraper for the disc opener blades.

Remove the seed tube and check for wear. Excessive wear on the seed tube indicates a worn seed tube guard.

50881-9

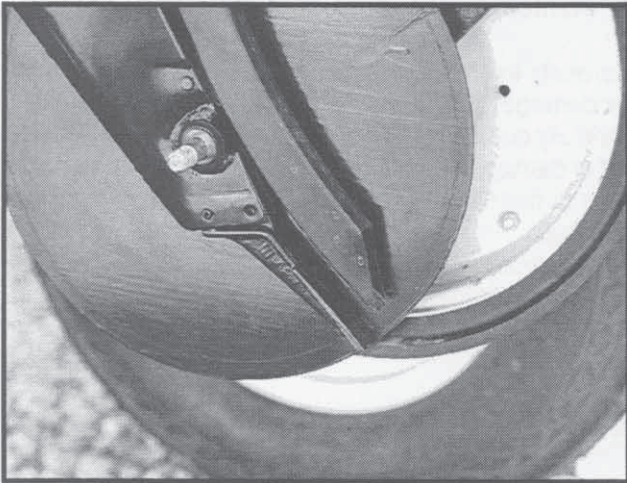

No till planting or planting in hard ground conditions will increase seed tube guard wear and necessitate more frequent inspection.

The gauge wheel and seed opener discs must be removed before the seed tube guard can be replaced.

ROW UNIT MOUNTED NO TILL COULTER

59386-40

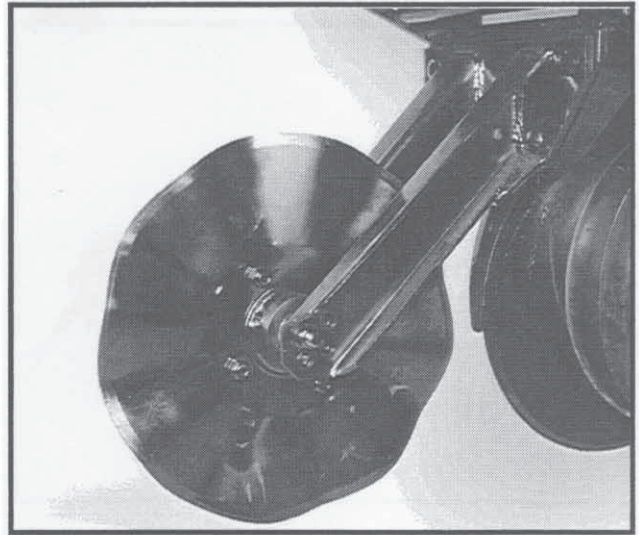

If properly maintained and lubricated the bearings in the row unit mounted no till coulters hub may never need to be replaced. Lubricate at frequency indicated in the Lubrication Section of this manual. Check periodically to be sure nuts and hardware are tightened to proper torque specification. Be sure the coulters is positioned square with the planter frame and aligned in front of row unit disc opener.

The coulters blade can be adjusted to one of four settings. Initially the blade is set in the highest position. As the blade wears it can be adjusted to one of the three lower settings. See "Row Unit Mounted No Till Coulters" in Operation Section of this manual.

When the 16" diameter coulters blade is worn to a 14 1/2" diameter (maximum allowable wear), it should be replaced.

Timely lubrication at the frequency indicated in the lubrication section of this manual is necessary to purge moisture and dirt from bearing and seal. This will also lubricate the seal. Add grease until it comes out around the seal.

MAINTENANCE

ELECTRONIC SEED MONITOR SYSTEM TROUBLESHOOTING

60656-5

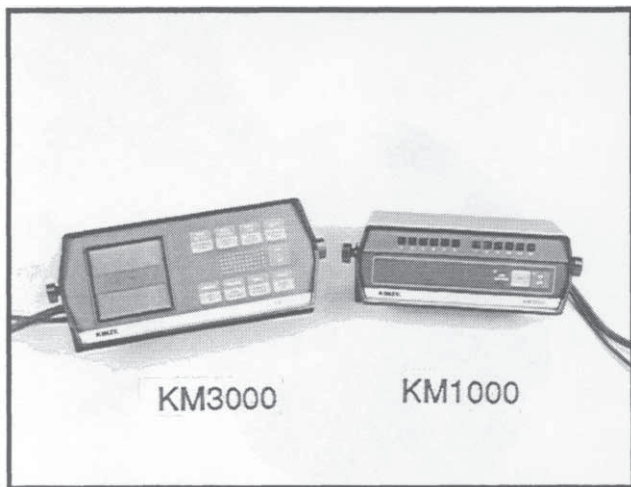

The general procedure to use, if a problem occurs, is to isolate the cause to a sensor, sensor lead, planter harness, console cable or the console, in that order. Make necessary repairs after problem has been isolated.

1. Sensors

Check for excessive dirt inside sensor. Check for cut or damaged wires. Connect sensor to the planter harness in a row that is operating properly. If it then operates correctly, sensor is good.

In some cases static electricity may cause dust and seed treatment to accumulate on the sensing elements in the sensor. Enough may accumulate to cause the sensor to malfunction, which can cause monitor to indicate a fault condition. Low humidity and dry soil conditions tend to cause this condition. When this occurs, clean the inside of the sensors, using a dry bottle brush.

If, for any reason a sensor becomes inoperative and a replacement sensor is not immediately available, disconnect the sensor lead connector from the planter harness, turn monitor OFF and then back ON. This will keep the alarm from sounding for this row only. Replace the defective seed sensor (using high rate seed sensor only) as soon as possible. After sensor is replaced make certain the monitor is turned OFF and back ON to reactivate the sensor position.

If sensor leads are damaged, carefully cut away the cable covering at the damaged area. Repair damaged wire or wires by soldering wires together, being sure to match wire colors, then tape each repaired wire. Finally, tape over cut portion of the cable cover. If necessary, relocate and secure cable so that the same type of damage will not occur again.

2. Planter Harness And Console Cable

Carefully examine planter harness and console cable for damage. If harness and/or cable is cut or pinched, carefully cut away the harness/cable covering. Repair cut or damaged wire by soldering wires together, being sure to match wire colors. Tape each repaired wire, then tape over cut harness/cable covering. If necessary, relocate and secure harness/cable so that the same type damage will not occur again.

3. Console

Check for a blown fuse, located on the console rear panel. Check battery connections and make certain they are clean and tight. Make certain battery is fully charged.

If console fuse is blown replace with a 5-amp type AGC. If fuse blows again, console needs repair or replacement.

CAUTION: DO NOT REPLACE FUSE WITH A FUSE HAVING A HIGHER AMPERAGE RATING.

If the battery cable is not damaged, battery connections are clean and tight and the battery is fully charged, the console is defective and needs to be repaired or replaced.

MAINTENANCE

KM1000 TROUBLESHOOTING CHART

SYMPTOM	PROBABLE CAUSE	ACTION REQUIRED
1. Low Voltage Indicator is ON.	<p>Connected to 6 volt battery. System voltage insufficient. Battery connection corroded.</p> <p>Console defective.</p>	<p>Connect to 12 volt battery. Insure greater than 11.0 volts. Inspect battery connections. If console power cable terminals or battery terminals are dirty or corroded, clean terminals as required. Repair or replace console. Contact your KINZE Dealer.</p>
2. One row indicator lamp fails to flash when planting. Alarm does not sound.	Burned out row indicator lamp.	Replace row indicator lamp with a 1892 lamp only. (Part No. R0595).
3. One row indicator lamp fails to flash when planting. Alarm sounds continuously. Seeds are being planted by the row unit.	<p>Sensing elements inside seed sensor.</p> <p>Defective sensor.</p>	<p>Clean sensing elements using a dry bottle brush. NOTE: Some seed treatment chemicals are detrimental to the operation of seed sensors and refuse to be removed by dry brushing. To remove such treatment from the inside of a sensor, proceed as follows: Wet a bottle brush with water, then apply a moderate amount of kitchen cleanser (such as Ajax® or Comet®) to the brush. Scrub inside of sensor until treatment is removed, then rinse sensor in clear cold water. Dry thoroughly.</p> <p>Plug suspect sensor cable into an adjacent row that is operating correctly. If sensor does not operate, sensor is defective.</p> <p>If you wish to continue planting and a replacement sensor is not available, disconnect the defective sensor cable from the planter harness, turn the monitor OFF and then back ON. The monitor will ignore the disconnected row sensor and you can continue to monitor all other rows.</p>

MAINTENANCE

KM1000 TROUBLESHOOTING CHART (Continued)

SYMPTOM	PROBABLE CAUSE	ACTION REQUIRED
<p>4. One row indicator lamp fails to come on when the console is powered up.</p>	<p>Burned out row indicator lamp.</p> <p>Defective seed sensor or planter harness.</p> <p>Defective seed sensor or planter harness.</p> <p>Console defective.</p>	<p>Replace row indicator lamp with a number 1892 lamp only. (Part No. R0595)</p> <p>Disconnect the suspected sensor from the planter harness row lead. Disconnect the sensor from the planter harness of an adjacent row. Reverse the harness row leads to the sensors (connect the suspected sensor to the adjacent row planter harness lead and the adjacent sensor to the suspected row harness lead).</p> <p>Turn console power OFF then back ON. If the symptom moves to the adjacent row, the seed sensor is defective and needs replaced. If the symptom does not move, the planter harness or console is defective and needs repaired. Visually inspect the planter harness for cuts, pinching, etc., if damage is found, repair by cutting away the cable covering and splicing the wires (being sure to match wire colors). Solder the splices and tape each wire individually. Tape over repaired cable.</p> <p>Repair or replace console. Contact your KINZE Dealer.</p>
<p>5. Monitor completely "dead".</p>	<p>Blown fuse.</p> <p>Poor battery connections.</p>	<p>Check fuse, located on rear panel of console. If fuse is blown, replace with a 5-amp, type AGC. If fuse blows again, check power connection to battery. If connections are reversed fuse will blow. If battery connections are correct, console needs repair or replacement. Contact your KINZE Dealer.</p> <p>Check battery connections. Connections must be clean and tight.</p>

MAINTENANCE

KM1000 TROUBLESHOOTING CHART (Continued)

SYMPTOM	PROBABLE CAUSE	ACTION REQUIRED
5. (Cont'd.)	<p>Cut or broken battery cable.</p> <p>Console defective.</p>	<p>Visually inspect the battery cable for a cut or broken wire. If wires are cut or broken, splice the wires being sure to match wire colors. Solder the splices and tape each wire individually. USE ONLY ROSIN CORE SOLDER.</p> <p>Repair or replace console. Contact your KINZE Dealer.</p>
6. When monitor is turned ON, row indicator lamps are dark, green power indicator is ON and monitor will not enter operate mode.	<p>Defective seed sensor.</p> <p>Planter harness shorted.</p> <p>Console defective.</p>	<p>Leave monitor turned on. Unplug seed sensors one at a time starting with row 1. When you disconnect a sensor and the remaining row indicator lamps come on, the sensor or its cable is defective. Visually inspect the sensor cable. If damaged, repair. If no cable damage is found, the sensor is defective and needs to be replaced.</p> <p>If all but the last sensor is disconnected and the problem still exists, reconnect a sensor before disconnecting the last sensor. If the last sensor is disconnected and the problem still exists, the planter harness, console cable or console is at fault.</p> <p>Visually inspect the planter harness (including all row unit cables) for cuts, pinching and other types of damage. If damage is found, cut away cable covering and repair the individual wires. Tape over repaired wire and cable.</p> <p>If the console cable, planter harness, and seed sensors are normal, the console is at fault and needs to be repaired or replaced. Contact your KINZE Dealer.</p>

MAINTENANCE

KM3000 TROUBLESHOOTING CHART

SYMPTOM	PROBABLE CAUSE	ACTION REQUIRED
<p>1. Display readout incomplete (fragmented) alarm sounds continuously.</p>	<p>Low battery voltage.</p> <p>Battery connections corroded.</p> <p>Console defective.</p>	<p>Recharge or replace battery.</p> <p>Inspect battery connection. If console power cable terminals or battery terminals are dirty or corroded, clean terminals as required.</p> <p>Repair or replace console. Contact your KINZE Dealer.</p>
<p>2. One row indicator segment (lower display) fails to flash when planting. Population readout for the planter row is .0. Alarm sounds continuously. Seeds are being planted by the row unit.</p>	<p>Sensing elements inside of seed sensor are dirty.</p> <p>Defective sensor.</p>	<p>Clean sensing elements using a dry bottle brush.</p> <p>NOTE: Some seed treatment chemicals are detrimental to the operation of seed sensors and refuse to be removed by dry brushing. To remove such treatment from the inside of a sensor proceed as follows: Wet a bottle brush with water, then apply a moderate amount of kitchen cleanser (such as Ajax® or Comet®) to the brush. Scrub inside of sensor until treatment is removed, then rinse sensor in clear cold water. Dry thoroughly.</p> <p>Plug suspect sensor cable into an adjacent row that is operating correctly. If sensor does not operate, sensor is defective.</p> <p>If you wish to continue planting and a replacement sensor is not available, disconnect the defective sensor cable from the planter harness, turn the monitor OFF and then back ON. The monitor will ignore the disconnected row sensor and you can continue to monitor all other rows.</p>

MAINTENANCE

KM3000 TROUBLESHOOTING CHART (Continued)

SYMPTOM	PROBABLE CAUSE	ACTION REQUIRED
<p>3. Monitor completely "dead".</p>	<p>Blown console fuse.</p> <p>Poor battery connections.</p> <p>Cut or broken battery cable.</p> <p>Low battery voltage.</p> <p>Console defective.</p>	<p>Check fuse, located on rear panel of console. If fuse is blown, replace with a 5-amp, type AGC. If fuse blows again, check power connection to battery. If connections are reversed fuse will blow. If battery connections are correct, console needs to be repaired or replaced. Contact your KINZE Dealer.</p> <p>Check battery connections. Connections must be clean and tight.</p> <p>Visually inspect the battery cable for a cut or broken wire. If wires are cut or broken, splice the wires being sure to match wire colors. Solder the splices and tape each wire individually. USE ONLY ROSIN CORE SOLDER.</p> <p>Check battery voltage. Must be at least 12 volts. If not, recharge or replace battery.</p> <p>Repair or replace console. Contact your KINZE Dealer.</p>
<p>4. When monitor is turned ON, row display (lower display) remains blank. Upper display shows SPEED, NUMBER OF ROWS, and ROW SPACING constants. Monitor will not enter OPERATE mode.</p>	<p>Defective (shorted) seed sensor.</p>	<p>Leave monitor turned ON. Unplug seed sensors one at a time starting with row 1. When you disconnect a sensor and the remaining row display segments come on and the monitor enters the operate mode, the sensor or its cable is defective. Visually inspect the sensor cable, if damaged repair. If no cable damage is found, the sensor is defective and needs replaced. If all sensors are disconnected and problem still exists, the planter harness, console cable or console is at fault.</p>

MAINTENANCE

KM3000 TROUBLESHOOTING CHART (Continued)

SYMPTOM	PROBABLE CAUSE	ACTION REQUIRED
4. (Cont'd.)	Planter harness shorted.	Visually inspect the planter harness (including all row unit cables) for cuts, pinching and other types of damage. If damage is found, cut away cable covering and repair the individual wires. Tape over repaired wire and cable.
	Console cable shorted.	Visually inspect the console cable for cuts, pinching and other types of damage. If damage is found, cut away cable covering and repair the individual wires. Tape over repaired wire and cable.
	Console defective.	If the console cable, planter harness and seed sensors are normal, the console is at fault and needs to be repaired or replaced. Contact your KINZE Dealer.

SEED MONITOR ROW INDICATOR BULB REPLACEMENT (KM1000 Only)

D-0802-0002/D-0802-0003

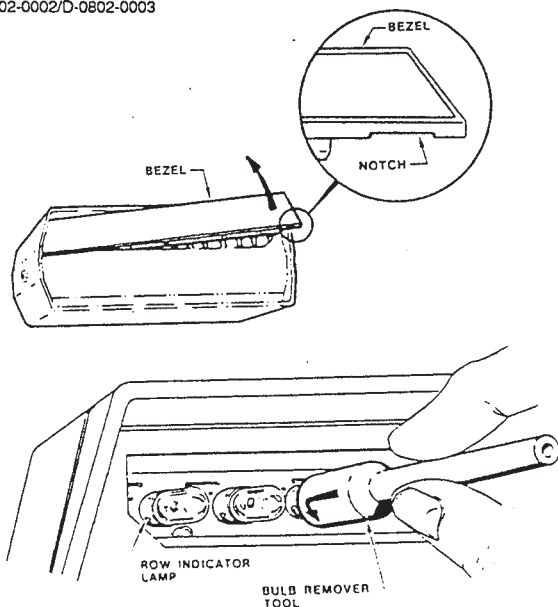

Carefully remove the row indicator bezel as shown. Use your fingernail to pry up along the lower outside edge of the bezel. Remove bezel. Remove burned out bulb using a bulb remover tool. Press in on bulb, turn 1/4 turn counterclockwise and remove bulb. Replace bulb with a No. 1892 (Part No. R0595) only. Replace bezel.

SEED MONITOR DISPLAY BACKLITE BULB REPLACEMENT (KM3000 Only)

D-0841-0006

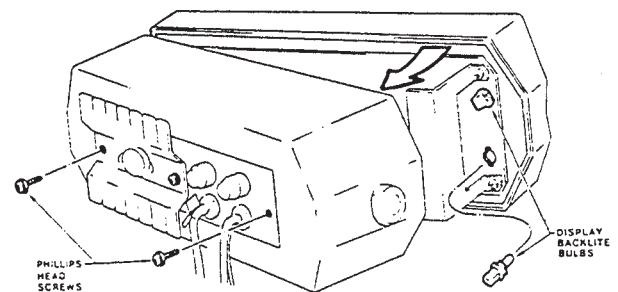

Remove the two outside Phillips head screws. **NOTE: DO NOT REMOVE THE CENTER PHILLIPS HEAD SCREW.** Carefully separate the console case from the front panel. Remove the defective bulb by turning the lamp assembly 1/4 turn counterclockwise and pulling straight out. Replace bulb with a GE #73 bulb (Part No. R1084). Carefully assemble the console front panel, case and rear panel and install the two Phillips head screws. **CAUTION: Make sure that all wires are located where they will not be pinched or cut.**

MAINTENANCE

WEAR PAD REPLACEMENT/ ADJUSTMENT

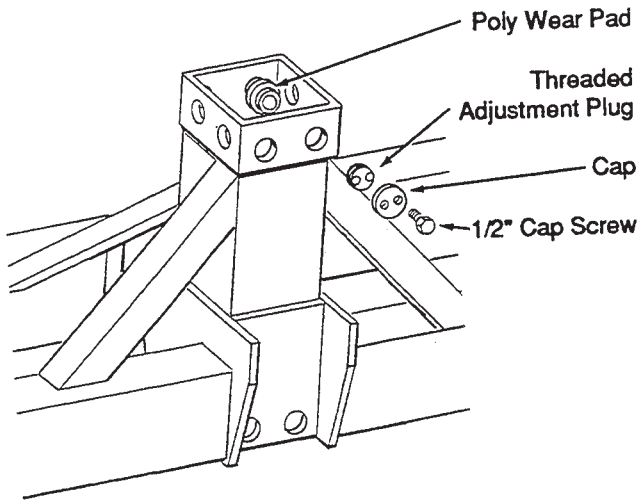

The center section of the planter consists of a steel tubular frame equipped with 16 adjustable wear pad assemblies which travel up and down against a stainless steel clad center post. Each adjustable wear pad assembly consists of a poly wear pad, a threaded adjustment plug and a cap. The assembly is held in place by the threaded adjustment plug and locked in place by the cap and two 1/2" hex head cap screws.

Check pad adjustment and wear annually.

To check adjustment and wear, park the planter on a level surface. Raise the planter to the raised field position. Visually check all 16 adjustable wear pad assemblies. Each wear pad assembly should lightly contact the stainless steel clad center post. The maximum allowable gap, when checked using a thickness gauge, should be no more than .060".

⚠ DANGER: Always install all safety lockups and safety lock pins before working under the unit.

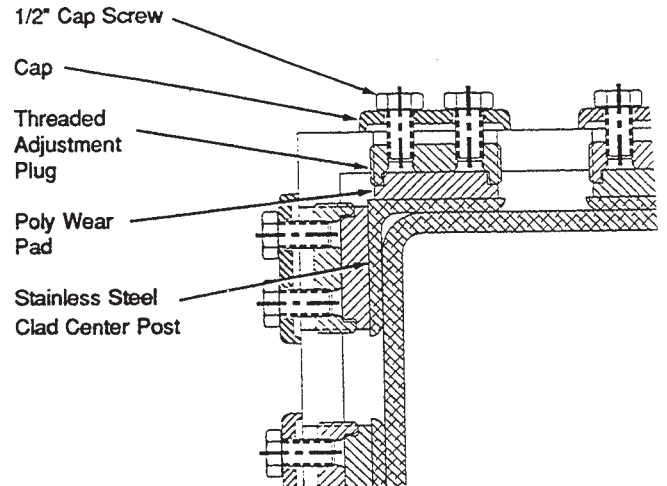

If adjustment is necessary proceed as follows: (a) Support the frame with safety stands at a comfortable working height with all row units off the ground. (b) Level the planter frame side to side and fore and aft with the planter axle. (c) To remove each wear pad assembly for inspection, remove the two 1/2" cap screws and cap. Reinstall the cap screws into the adjustment pad and remove the threaded adjustment plug and poly wear pad using the cap screws as a handle. (d) If a poly wear pad is worn to less than 1/8" as shown below, replace the wear pad.

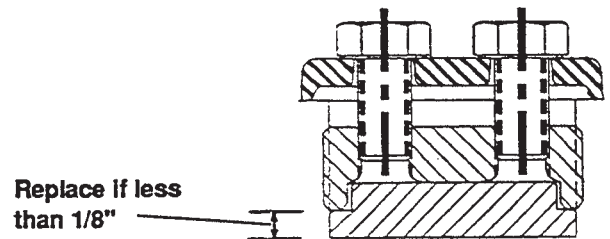

(e) Reinstall the wear pad assembly. (f) Hand tighten poly wear pad and adjustment plug until the poly wear pad lightly contacts the stainless steel clad center post. (g) Install cap using two 1/2" cap screws. Torque cap screws to 25-30 ft. lbs.

CAUTION: DO NOT OVER TIGHTEN WEAR PADS. OVER TIGHTENING WILL CAUSE PREMATURE WEAR.

MAINTENANCE

PISTON PUMP STORAGE

KEEP AIR OUT OF PUMP! This is the only way to prevent corrosion. Even for short periods of storage, the entrance of air into the pump, will cause RAPID AND SEVERE CORROSION.

Overnight Storage

SUSPENSION FERTILIZER must be flushed from the pump for ANY storage period.

Winter Storage

1. Flush pump thoroughly with 5 to 10 gallons of fresh water and circulate until all corrosive salts are dissolved in the pump.
2. With the pump set on 10, draw in a mixture of half diesel fuel and half 10 weight oil until the discharge is clean. Then plug inlet and outlet.

69045-6

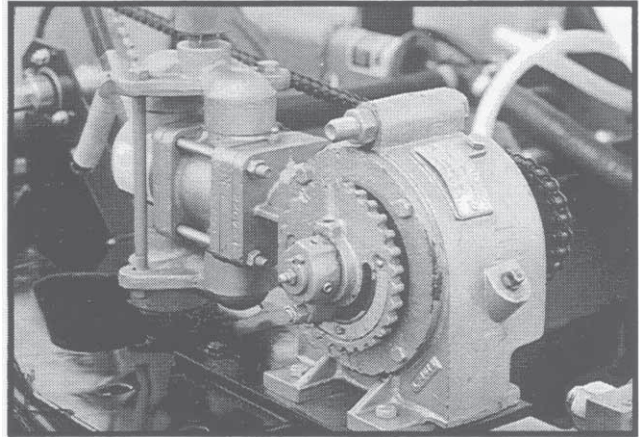

PISTON PUMP TROUBLESHOOTING		
Problem	Possible Cause	Solution
Pump hard or impossible to prime.	Valves fouled or in wrong place.	Inspect and clean valves.
	Air leak in suction line.	Repair leak.
	Pump set too low.	Adjust pump setting.
	Packing washers worn out.	Replace.
Low metering.	Valves fouled or in wrong place.	Inspect and clean valves.
	Air leak in suction line.	Repair leak.
	Pump set too low.	Adjust pump setting.
	Broken valve spring.	Replace spring.
Over meters.	Broken discharge valve spring.	Replace spring.
	Trash under valves.	Inspect and clean valves.
	Improper rate setting.	Adjust pump setting.
Leaks through when stopped.	Broken discharge valve spring.	Replace spring.
	Trash under valves.	Inspect and clean valves.
Fertilizer solution leaking under stuffing box.	Packing washers worn out.	Replace.
Pump using excessive oil.	Oil seals or o-ring worn and leaking.	Replace.
Pump operates noisily.	Crankcase components worn excessively.	Inspect and replace if necessary.

MAINTENANCE

VALVE BLOCK ASSEMBLY INSPECTION

The valve block assembly consists of the marker sequencing and flow control valves in one assembly.

The sequencing valve portion consists of a chambered body containing a spool and series of check valves to direct hydraulic oil flow. Should the valve malfunction, the components may be removed for inspection.

1. Remove valve block assembly from planter.
2. Remove detent assembly and port adapter assemblies from rear of valve block.
3. Remove plug from both sides of valve block and remove spool.
4. Inspect all parts for pitting, contamination or foreign material. Also check seating surfaces inside the valve. Replace any parts found to be defective.
5. Lubricate spool with a light oil and reinstall. Check to be sure spool moves freely in valve body.

IMPORTANT: Make sure correct check ball(s) and spring are installed in each valve bore upon reassembly.

A flow control valve is located on each side of the block assembly. The flow control valves should be adjusted for raise and lower speed as part of the assembly procedure or upon initial operation. If the valve fails to function properly or requires frequent adjustment, the needle valve should be removed for inspection. Check for foreign material and contamination. Be sure needle moves freely in adjustment screw. Replace any components found to be defective.

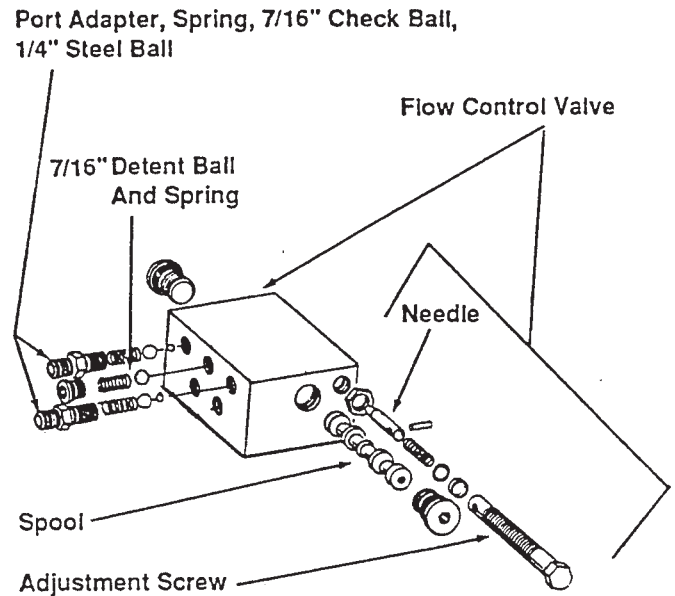

MAINTENANCE

MARKER OPERATION TROUBLESHOOTING		
PROBLEM	POSSIBLE CAUSE	POSSIBLE SOLUTION
Both markers lowering and only one raising at a time.	Hoses from cylinders to valve connected backwards.	Check hosing diagram in manual and correct.
Same marker always operating.	Spool in sequencing valve not shifting.	Remove spool, inspect for foreign material, making sure all ports in spool are open. Clean and re-install.
Both markers lower and raise at same time.	Foreign material under check ball in sequencing valve. Check ball missing or installed incorrectly in sequencing valve.	Remove hose fitting, spring and balls and clean. May be desirable to remove spool and clean as well. Disassemble and correct. See illustration in Parts Section.
Marker (in raised position) settling down.	Damaged o-ring in marker cylinder or cracked piston. Spool in sequencing valve not shifting completely because detent ball or spring is missing. Spool in sequencing valve shifting back toward center position.	Disassemble cylinder and inspect for damage and repair. Check valve assembly and install parts as needed. Restrict flow of hydraulic oil from tractor to sequencing valve.
Neither marker will move.	Flow control closed too far. Hand-operated selector valve in "transport functions" position.	Loosen locking nut and turn flow control adjustment bolt out or counterclockwise until desired speed is set. Remove hydraulic pressure from the system and move selector handle to "marker function" position.
Markers moving too fast.	Flow control open too far.	Loosen locking nut and turn flow control adjustment bolt in or clockwise until desired speed is set.
Sporadic marker operation speed.	Needle sticking open in flow control valve.	Remove flow control, inspect and repair or replace.

MAINTENANCE

MARKER BEARING LUBRICATION OR REPLACEMENT

1. Remove marker blade.
2. Remove hub cap from hub.
3. Remove cotter pin, nut and washer.
4. Slide hub from spindle.
5. Remove bearings and cups and discard if bearings are being replaced. Clean hub and dry. Remove bearings only if repacking.
6. Press in new bearing cups with thickest edge facing in. (Bearing replacement procedure only.)
7. Pack bearings with heavy duty wheel bearing grease thoroughly forcing grease between roller cone and bearing cage. Also, fill the space between the bearing cups in the hub with grease.
8. Place inner bearing in place and press in new rubber seal and grease seal.
9. Clean spindle and install hub.
10. Install outer bearing, washer and slotted hex nut. Tighten slotted hex nut while rotating hub until there is some drag. This assures that all bearing surfaces are in contact. Back off slotted nut to nearest locking slot and install cotter pin.
11. Fill hub caps approximately 3/4 full of wheel bearing grease and install on hub.
12. Install blade and hub cap retainer on hub and tighten evenly and securely.

MKR020

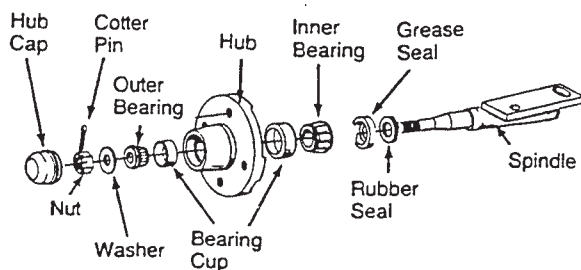

WHEEL BEARING LUBRICATION OR REPLACEMENT

1. Raise tire clear of ground and remove wheel.
2. Remove double jam nuts and slide hub from spindle.
3. Remove bearings and cups and discard if bearings are being replaced. Clean hub and dry. Remove bearings only if repacking.
4. Press in new bearing cups with thickest edge facing in. (Bearing replacement procedure only.)
5. Pack bearings with heavy duty wheel bearing grease thoroughly forcing grease between roller cone and bearing cage. Also fill the space between the bearing cups in the hub with grease.
6. Place inner bearing in place.
7. Clean spindle and install hub.
8. Install outer bearing and nut. Tighten jam nut while rotating hub until there is some drag. This assures that all bearing surfaces are in contact. Back off jam nut 1/4 turn or until there is only slight drag when rotating the hub. Install second jam nut to lock against first.
9. Install wheel on hub and tighten evenly and securely.

PTD057

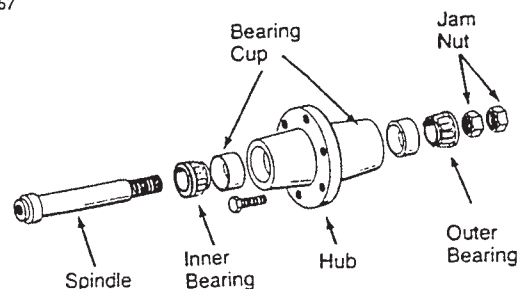

MAINTENANCE

PREPARATION FOR STORAGE

Store the planter in a dry sheltered area if possible.

Remove all trash that may be wrapped on sprockets or shafts and remove dirt that can draw and hold moisture.

Clean all drive chains and coat with a rust preventative spray, or remove chains and submerge in oil.

Lubricate planter and row units at all lubrication points.

If possible, remove weight from all tires particularly if the unit is stored outdoors, in which case it is best to remove wheels and tires for storage in a cool dry area.

Inspect the planter for parts that are in need of replacement and order during the "off" season.

Make sure all seed, herbicide and insecticide hoppers are empty and clean.

Clean seed meters and store in a dry area.

Remove seed discs from brush-type seed meter, clean and store meters with discs removed.

Grease exposed areas of cylinder rods before storing planter.

Grease or paint disc openers and marker blades to prevent rust.

Flush liquid fertilizer tanks, hoses and pump with clean water.

Empty dry fertilizer hoppers, clean hoppers, disassemble and clean metering augers, reassemble coating all metal parts with rust preventative.

The center post is clad with stainless steel. To prolong service life keep stainless steel surface clean and free of any lubrication. CENTER POST AND POLY WEAR PAD REQUIRES NO LUBRICATION. ANY OIL OR GREASE WILL ATTRACT DIRT AND ACCELERATE WEAR ON THE CENTER POST AND ON THE POLY WEAR PAD.

WIRING DIAGRAM

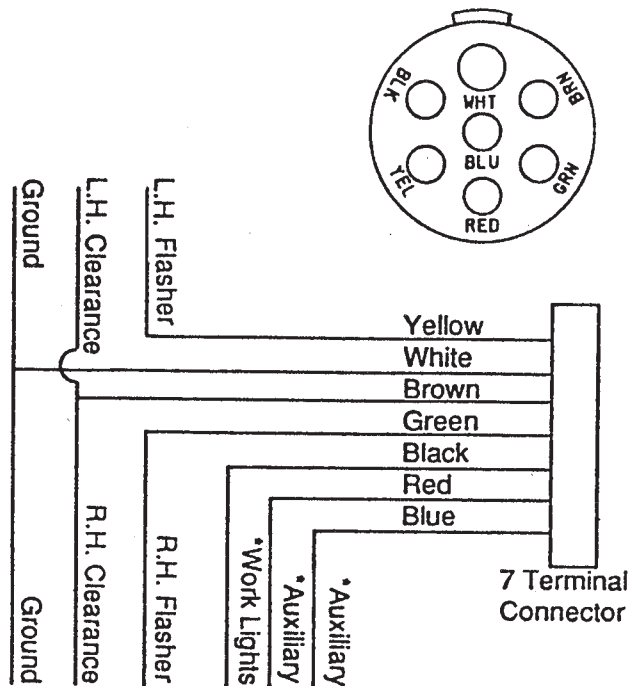

* Optional lights and wires (to be supplied by customer) may be wired into existing plug terminals.

Light package supplied on the Model 2500 planter meets ASAE standards. For the correct wiring harness to be wired into the lights on your tractor, check with the tractor manufacturer.

69922-35

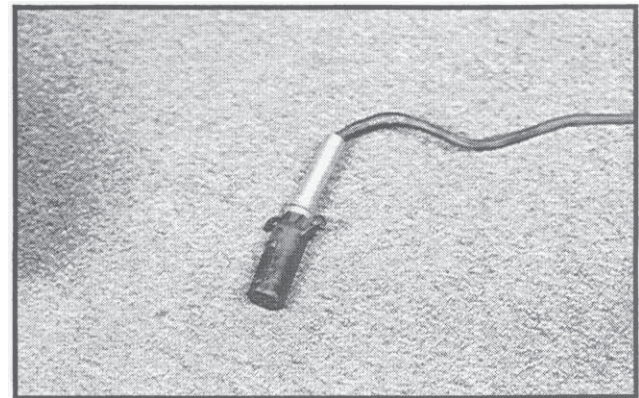

PARTS LIST INDEX

ROW UNIT

Shank Assembly	P2/P3
Parallel Arms, Mounting Bracket And Quick Adjustable Down Force Springs	P4
Gauge Wheel	P5
Closing Wheel	P6
Hopper Support And Meter Drive	P7
Seed Hopper	P8
Finger Pickup Corn Meter	P9
Brush-Type Seed Meter	P10
Granular Chemical Banders	P11
Granular Chemical Hopper With Meter(s) And Throwout	P12/P13
No Till Coulter, Row Unit Mounted	P14
Disc Furrower, Row Unit Mounted	P15
Frame Mounted Coulter W/Disc Furrower	P16/P17
Spring Tooth Incorporator	P18/P19

BASE MACHINE

Inner Hitch	P22/P23
Outer Hitch	P24/P25
Frame Assembly	P26/P27
Axle/Pivot And Wheel Assembly	P28/P29
Contact Drive Wheel And Arm Assembly	P30/P31
Drive Line	P32/P33
Transmission Assembly	P34/P35
Marker Assembly	P36/P39
Marker Spindle/Hub/Blade	P40
Cylinders	P41/P42
Marker Sequencing/Flow Control Valve	P43
Selector Valve	P43
Hydraulic System	P44/P45

ELECTRONIC SEED MONITOR

Electronic Seed Monitor	P46/P47
-------------------------------	---------

INTERPLANT

Interplant Drive	P48/P49
Interplant Push Unit	P20/P21

FERTILIZER

Double Disc Fertilizer Opener And Mounting Bar	P50/P51
Single Disc Fertilizer Opener	P52/P53
Dry Fertilizer Transmission Assembly	P54
Dry Fertilizer Couplers/Shafts	P55
Dry Fertilizer Hopper And Mounts	P56/P57
Liquid Fertilizer Tanks, Saddles, Mounts, Hoses And Fittings	P58/P59
Liquid Fertilizer Squeeze Pump Mounting Brackets And Drive Line	P60/P61
Liquid Fertilizer Squeeze Pump	P62/P63
Liquid Fertilizer Piston Pump Mounting Brackets And Drive Line	P64/P65
Liquid Fertilizer Piston Pump	P66/P69
Liquid Fertilizer Piston Pump Flow Divider	P70/P71

Decals, Reflectors And Tie Straps	P72/P73
---	---------

Numerical Index	a
-----------------------	---

SHANK ASSEMBLY

RUB006/RUA004

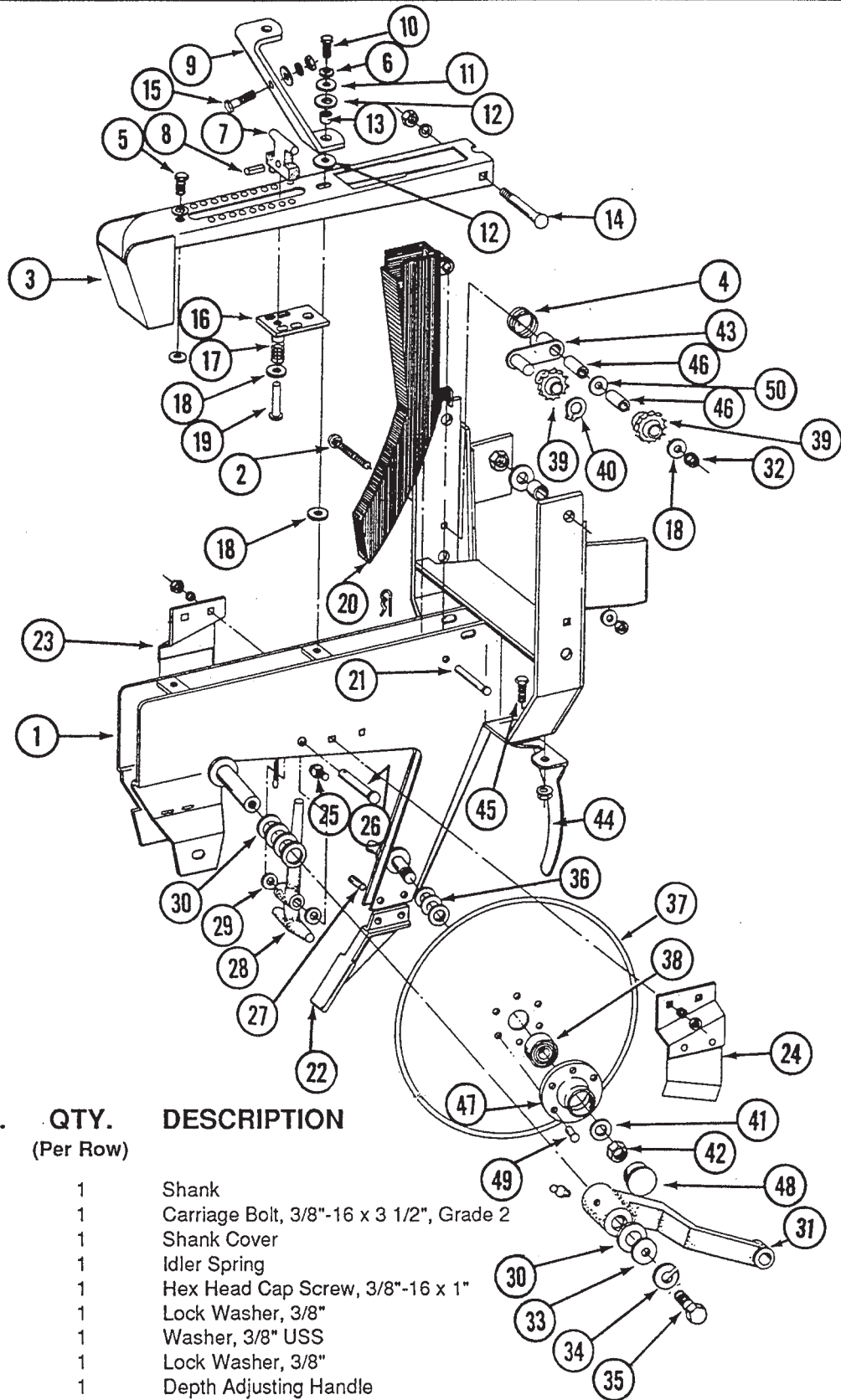

ITEM	PART NO.	QTY. (Per Row)	DESCRIPTION
1.	GA0860	1	Shank
2.	G10307	1	Carriage Bolt, 3/8"-16 x 3 1/2", Grade 2
3.	GA0811	1	Shank Cover
4.	GD1065	1	Idler Spring
5.	G10001	1	Hex Head Cap Screw, 3/8"-16 x 1"
	G10229	1	Lock Washer, 3/8"
	G10210	1	Washer, 3/8" USS
6.	G10229	1	Lock Washer, 3/8"
7.	GB0102	1	Depth Adjusting Handle
8.	G10605	1	Spring Pin, 5/32" x 3/4"
9.	GD1027	1	Stabilizer Bracket
10.	G10003	1	Hex Head Cap Screw, 3/8"-16 x 1 1/2"
11.	G10208	1	Special Washer, 13/32"
12.	GD1120	2	Rubber Washer

SHANK ASSEMBLY

ITEM	PART NO.	QTY. (Per Row)	DESCRIPTION
13.	GD1110	1	Bushing
14.	G10304	1	Carriage Bolt, 3/8"-16 x 3", Grade 2
	G10229	1	Lock Washer, 3/8"
	G10101	1	Hex Nut, 3/8"-16
15.	G10305	1	Carriage Bolt, 3/8"-16 x 1", Grade 2
	G10210	1	Washer, 3/8" USS
	G10229	1	Lock Washer, 3/8"
	G10101	1	Hex Nut, 3/8"-16
16.	GB0105	1	Depth Adjusting Slide
17.	GD1066	1	Compression Spring
18.	G10210	1	Washer, 3/8" USS
19.	G10552	1	Clevis Pin, 3/8" x 2"
20.	GD1130	-	Seed Tube, Regular
	GA5880	-	Seed Tube W/High Rate Sensor
	GR1062	-	Seed Tube (With holes for high rate sensor installation)
	GR1087	-	Sensor Only (For GA5880)
21.	G10551	1	Clevis Pin, 1/4" x 2 1/2"
	G10669	1	Hair Pin Clip, No. 22
22.	GB0103	1	Seed Tube Guard
23.	GA2012L	1	Disc Scraper, Left Hand
24.	GA2012R	1	Disc Scraper, Right Hand
25.	G10328	4	Hex Head Cap Screw, 3/8"-16 x 5/8"
	G10229	4	Lock Washer, 3/8"
	G10101	4	Hex Nut, 3/8"-16
26.	G10555	1	Clevis Pin, 1/2" x 2 1/2"
	G10451	1	Cotter Pin, 1/8" x 1"
27.	G10601	2	Spring Pin, 1/4" x 3/4"
28.	GB0104	1	Depth Adjusting Stop
29.	G10206	2	Washer, 1/2"
30.	G10526	-	Spacer Washer, 1 1/64" (As Required)
31.	GA2116	2	Wheel Arm With Grease Fitting
	G10640	2	Grease Fitting, 1/4"-20
32.	G10108	1	Lock Nut, 3/8"-16
33.	G10216	2	Washer, 1/2" USS
34.	G10228	2	Lock Washer, 1/2"
35.	G10014	2	Hex Head Cap Screw, 1/2"-13 x 1"
36.	G10213	-	Machine Bushing, 1 3/64" (As Required)
37.	GD1030	2	Disc, 15"
38.	GA2014	2	Bearing
39.	GD7426	2	Idler Sprocket
40.	G10435	1	Retaining Ring
41.	G10204	2	Washer, 21/32"
42.	G10503	1	Jam Nut, 5/8"-11, Right Hand
	G10504	1	Jam Nut, 5/8"-11, Left Hand
43.	GA2056	1	Idler Arm
44.	GD1033	1	Shield
45.	G10303	2	Carriage Bolt, 5/16"-18 x 1", Grade 2
	G10620	2	Flange Nut, 5/16"-18
46.	GD1026	2	Spacer
47.	GD1031	2	Housing
48.	GD6533	2	Bearing Cap
49.	G10427	12	Rivet, 1/4" x 1/2"
50.	G10384	1	Special Washer, 3/8"
A.	GA2013	-	Disc And Bearing Assembly, Less Bearing Cap (Items 37-38, 47 and 49)

PARALLEL ARMS, MOUNTING BRACKET AND QUICK ADJUSTABLE DOWN FORCE SPRINGS

RUB007/RUB015/RUB016/RUB013

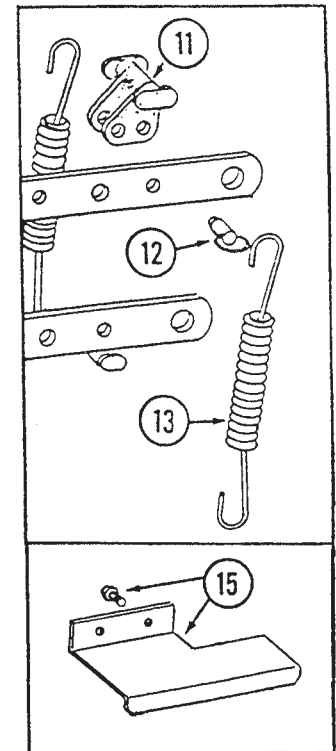
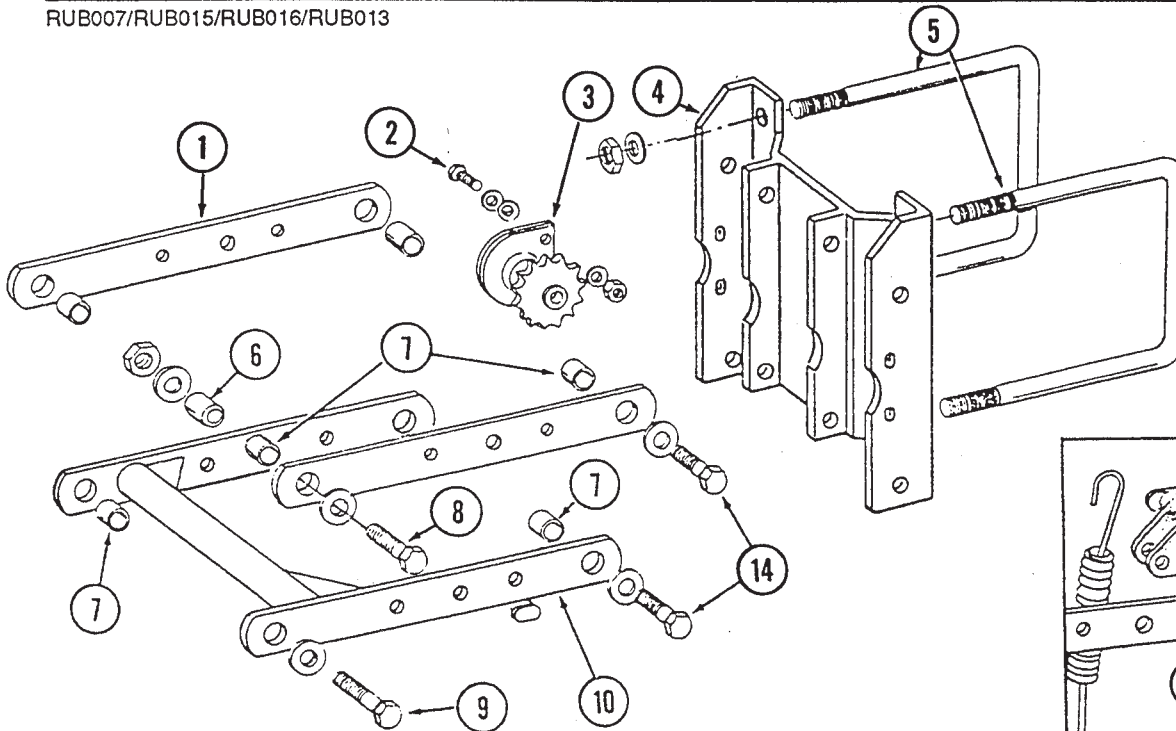

ITEM	PART NO.	QTY. (Per Row)	DESCRIPTION
1.	GD7619	2	Upper Arm
2.	G10004	2	Hex Head Cap Screw, 3/8"-16 x 1 1/4"
	G10210	-	Washer, 3/8" USS (As Required)
	G10229	2	Lock Washer, 3/8"
	G10101	2	Hex Nut, 3/8"-16
3.	GA1720	1	Bearing/Sprocket, 7/8" Bore
4.	GA5798	1	Support Plate
5.	GD1113	2	U-Bolt, 5" x 7" x 5/8"-11
	G10230	4	Lock Washer, 5/8"
	G10104	4	Hex Nut, 5/8"-11
6.	GD1109	2	Pivot Bushing
7.	GB0218	8	Bushing
8.	G10006	2	Hex Head Cap Screw, 5/8"-11 x 2 1/4"
	GD7805	4	Special Washer
	G10107	2	Lock Nut, 5/8"-11
9.	G10005	2	Hex Head Cap Screw, 5/8"-11 x 1 3/4"
	GD7805	2	Washer, Special
	G10107	2	Lock Nut, 5/8"-11
10.	GA5651	1	Lower Arm
11.	GB0186	2	Spring Anchor
12.	G10545	2	Detent Pin, 1" Grip
13.	GD8249	2/4	Spring
14.	G10008	4	Hex Head Cap Screw, 5/8"-11 x 2"
	GD7805	4	Washer, Special
	G10107	4	Lock Nut, 5/8"-11
15.	G7192X	-	Chain Shield Package With Hardware (Used with Row Unit Mounted No Till Coulters)
	G10037	-	Hex Head Cap Screw, 1/2"-13 x 1 1/4"
	G10228	-	Lock Washer, 1/2"
	G10102	-	Hex Nut, 1/2"-13

GAUGE WHEEL

RUB001/RUA039/RUB018

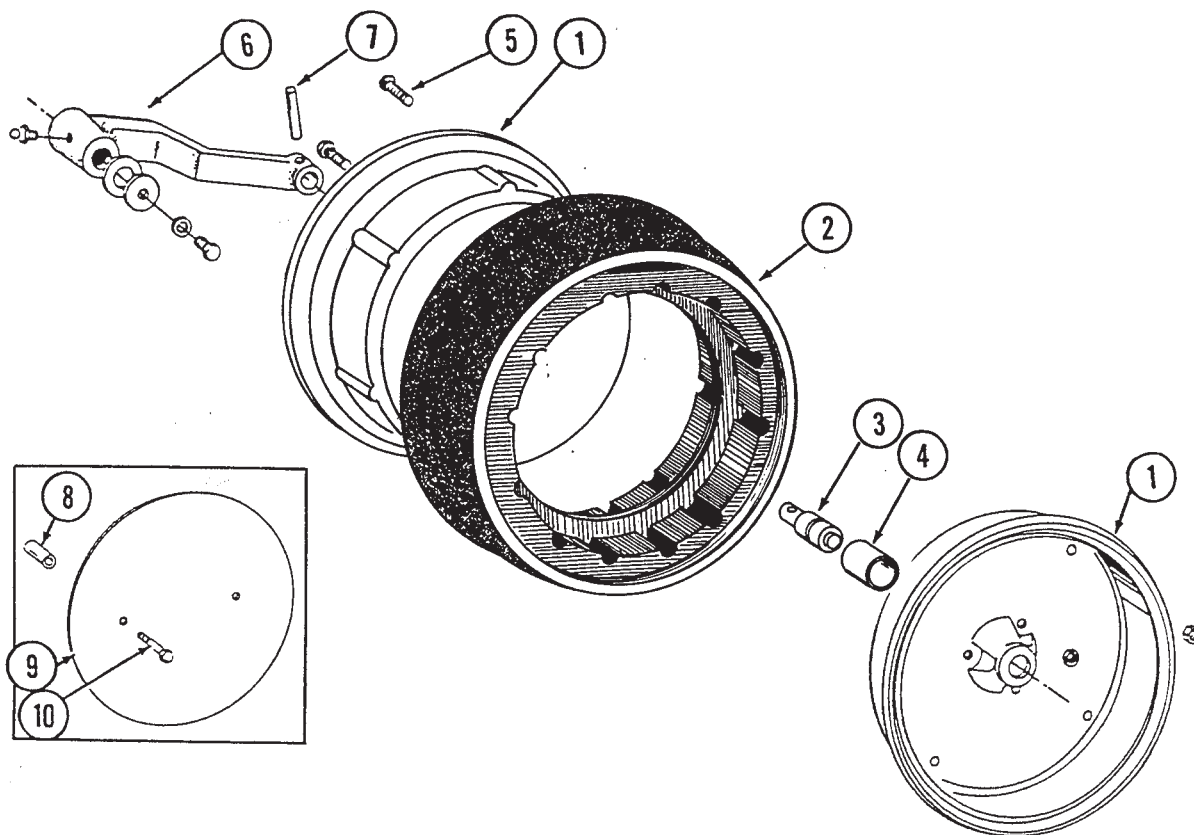

ITEM	PART NO.	QTY. (Per Row)	DESCRIPTION
1.	GD1048	4	Half Wheel
2.	GD1086	2	Tire
3.	GA2022	2	Bearing
4.	GB0118	2	Bearing Sleeve
5.	G10018	4	Hex Head Cap Screw, 5/16"-18 x 5/8"
	G10109	4	Lock Nut, 5/16"-18
6.	GA2116	2	Wheel Arm With Grease Fitting
	G10640	2	Grease Fitting, 1/4"-20
7.	G10603	2	Spiral Pin, 1/4" x 1 1/4"
8.	GD0973	4	Sleeve, 1 1/2"
9.	GD1353	2	Wheel Cover (Optional)
10.	G10069	4	Hex Head Cap Screw, 5/16"-18 x 2 1/4"
	G10232	4	Lock Washer, 5/16"
	G10106	4	Hex Nut, 5/16"-18
A.	GA2021	-	Gauge Wheel Complete (Items 1-5)

CLOSING WHEEL

RUB004

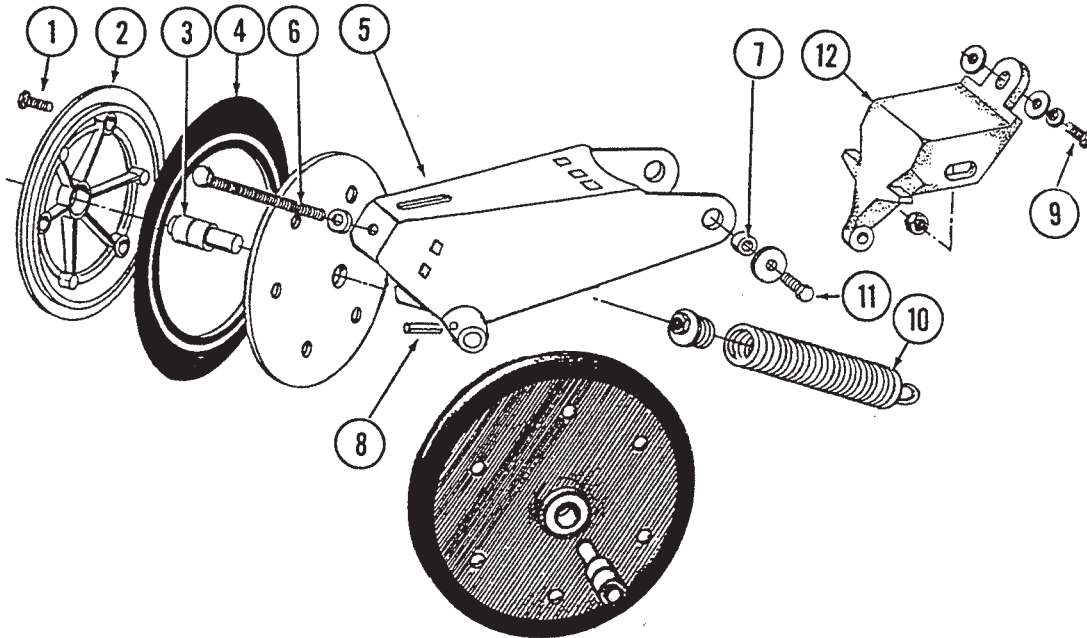

ITEM	PART NO.	QTY. (Per Row)	DESCRIPTION
1.	G10064	6	Hex Head Cap Screw, 1/4"-20 x 1"
	G10103	6	Hex Nut, 1/4"-20
2.	GR1180	4	Half Wheel Kit, Nylon, Includes (2) Half Wheels
3.	GA2022	2	Bearing
4.	GD1085	2	Tire, 1" x 15"
5.	GA6056	1	Arm With Spindles
6.	G10015	1	Hex Head Cap Screw, 1/2"-13 x 5", Grade 2 Full Thread
	G10525	1	Internal Tooth Lock Washer, 1/2"
7.	GD1111	2	Bushing
8.	G10603	2	Spiral Spring Pin, 1/4" x 1 1/4"
9.	G10003	1	Hex Head Cap Screw, 3/8"-16 x 1 1/2"
	G10229	1	Lock Washer, 3/8"
	G10210	2	Washer, 3/8" USS
10.	GA2054	1	Spring With Plug
11.	G10016	2	Hex Head Cap Screw, 1/2"-13 x 2"
	G10216	2	Washer, 1/2" USS
	G10111	2	Lock Nut, 1/2"-13
12.	GB0113	1	Wheel Arm Stop
A.	GA3086	-	Standard Closing Wheel Complete With Bearing, Nylon (Items 1-4)

HOPPER SUPPORT AND METER DRIVE

RUB005

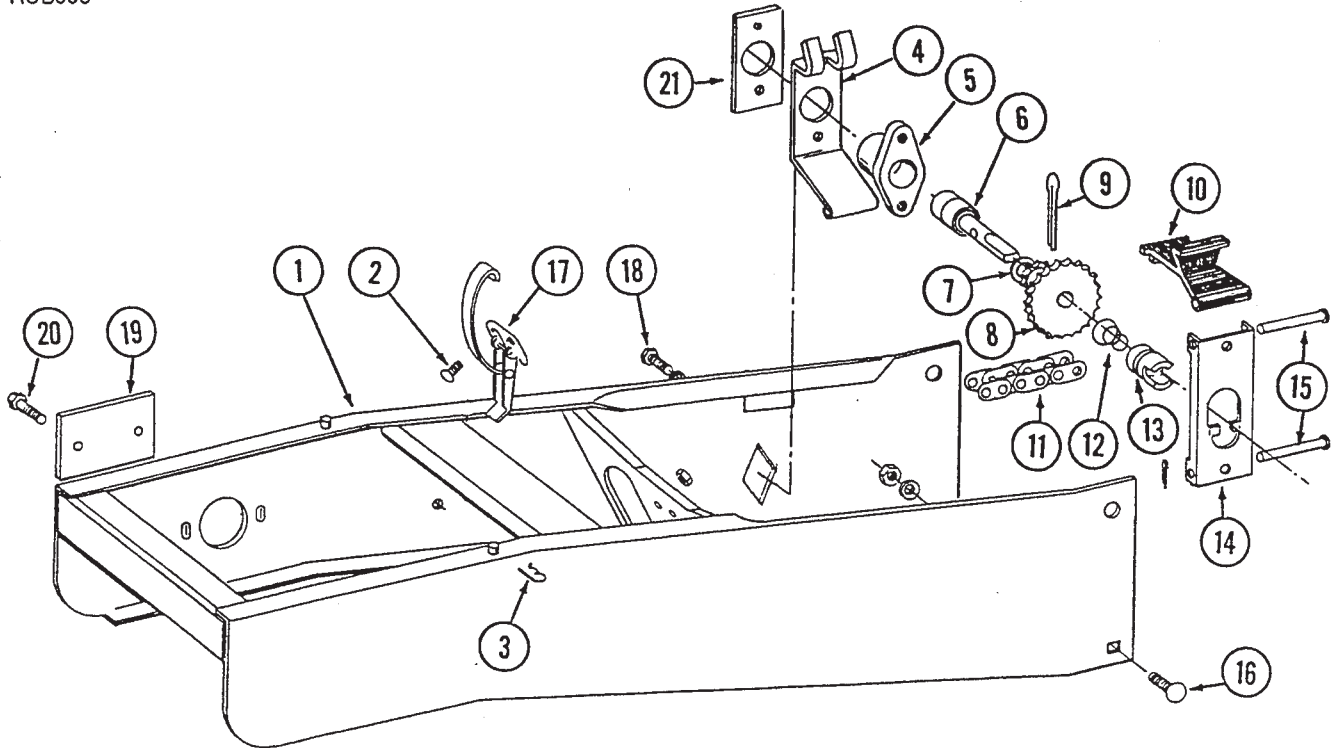

ITEM	PART NO.	QTY. (Per Row)	DESCRIPTION
1.	GA5906	1	Hopper Support
2.	G10309	2	Carriage Bolt, 1/4"-20 x 5/8", Grade 2
	G10621	2	Flange Nut, 1/4"-20
3.	G10670	2	Spring Locking Pin, No. 3
4.	GD1037	1	Bearing Support
5.	GB0108	1	Bearing Housing
6.	GA2016	1	Bearing
7.	G10204	-	Machinery Bushing, 21/32" (As Required)
8.	GB0107	1	Sprocket, 11/19 Tooth
9.	G10457	1	Cotter Pin, 5/32" x 1 1/2"
10.	GD1035	1	Release Handle
11.	G3303-98	1	Roller Chain, No. 41, 98 Links Including Connector Link
	GR0196	1	Connector Link, No. 41
12.	GD8458	1	Compression Spring
13.	GB0109	1	Drive Coupler
14.	GD1036	1	Drive Release Lever
15.	G10553	2	Clevis Pin, 1/4" x 2 5/8"
	G10455	2	Cotter Pin, 1/16" x 1/2"
16.	G10305	1	Carriage Bolt, 3/8"-16 x 1", Grade 2
	G10229	1	Lock Washer, 3/8"
	G10101	1	Hex Nut, 3/8"-16
17.	GA2007	1	Hopper Hold Down Latch
18.	G10019	2	Hex Head Cap Screw, 5/16"-18 x 1"
	G10232	2	Lock Washer, 5/16"
19.	GD7618	1	Cover
20.	G10312	2	Carriage Bolt, 5/16"-18 x 3/4"
	G10620	2	Flange Nut, 5/16"-18
21.	GD2128	1	Plate
A.	GA4822	-	Meter Drive Assembly Complete (Items 4-10,12-15, 18 And 21)

SEED HOPPER

RUA015

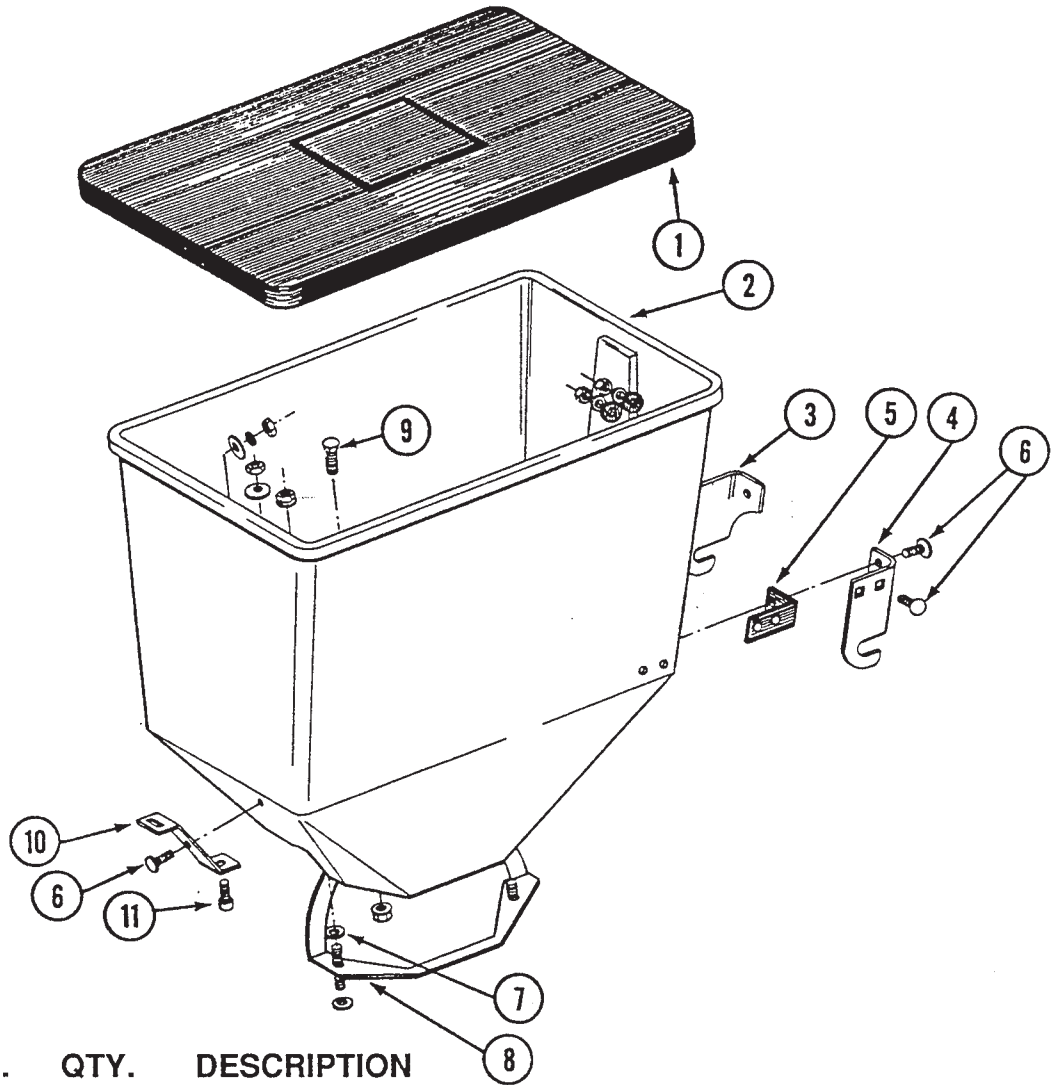

ITEM	PART NO.	QTY. (Per Row)	DESCRIPTION
1.	GA2327	1	Lid With Clip
2.	GD1053	1	Seed Hopper
3.	GD1051L	1	Bracket, Left Hand
4.	GD1051R	1	Bracket, Right Hand
5.	GD1054	2	Mounting Pad
6.	G10310	7	Carriage Bolt, 1/4"-20 x 3/4", Grade 2
	GD1121	7	Rubber Washer
	G10209	7	Washer, 1/4" USS
	G10110	7	Self Locking Nut, 1/4"-20
7.	GD1121	2	Rubber Washer
8.	GA2027	1	Retainer
9.	G10310	1	Carriage Bolt, 1/4"-20 x 3/4", Grade 2
	G10621	1	Whiz Lock Nut, 1/4"
10.	GD1055	1	Clip
11.	G10520	1	Hex Head Cap Screw, 3/8"-16 x 3/4", Grade 8
	G10210	1	Washer, 3/8" USS
	G10229	1	Lock Washer, 3/8"
	G10101	1	Hex Nut, 3/8"-16
A.	GA2058	-	Seed Hopper With Hardware, Less Lid (Items 2-11)

FINGER PICKUP CORN METER

RUA015

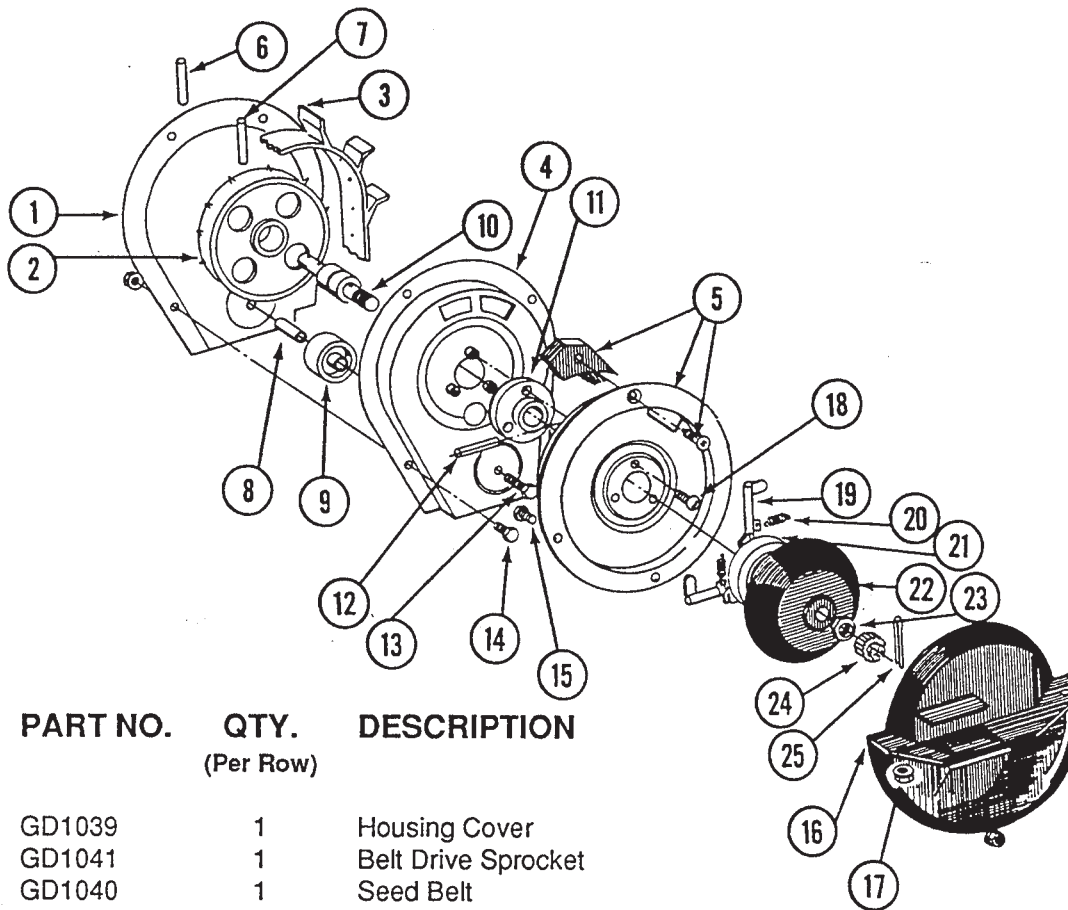

ITEM	PART NO.	QTY. (Per Row)	DESCRIPTION
1.	GD1039	1	Housing Cover
2.	GD1041	1	Belt Drive Sprocket
3.	GD1040	1	Seed Belt
4.	GA2018	1	Conveyor Housing
5.	GR0664	1	Carrier With Brush And Screw
	GA2020	-	Brush
	G10690	-	Rolling Thread Screw, No. 10 x 3/4"
6.	G10602	1	Spring Pin, 1/4" x 1 1/2"
7.	G10604	1	Spring Pin, 3/16" x 1 1/2"
8.	GB0120	1	Bushing
9.	GD1042	1	Idler
10.	GA2019	1	Bearing
11.	GB0110	1	Bearing Housing
12.	G10603	1	Spring Pin, 1/4" x 1 1/4"
13.	G10021	1	Hex Head Cap Screw, 1/4"-20 x 1 1/2"
	G10621	1	Flange Nut, 1/4"
14.	G10022	4	Hex Head Cap Screw, 1/4"-20 x 1/2"
	G10621	4	Flange Nut, 1/4"
15.	G10020	3	Hex Head Cap Screw, 1/4"-20 x 5/8"
	G10323	3	Hex Flange Nut, 1/4"-20
16.	GD1046	3	Seed Baffle
17.	G10620	2	Flange Nut, 5/16"-18
18.	G10401	3	Machine Screw, No. 10-32 x 5/8"
19.	GD1044	-	Finger (12 Per Meter)
20.	GD6501	12	Spring
21.	GB0111	1	Cam
22.	GD1045	1	Finger Holder
23.	G10500	1	Jam Nut, 5/8"-18 UNF
24.	GD1083	1	Cage Nut, 5/8"
25.	G10470	1	Cotter Pin, 5/32" x 1"
A.	GR0933	-	Finger Assembly (Items 19-22)

BRUSH-TYPE SEED METER

RUA037

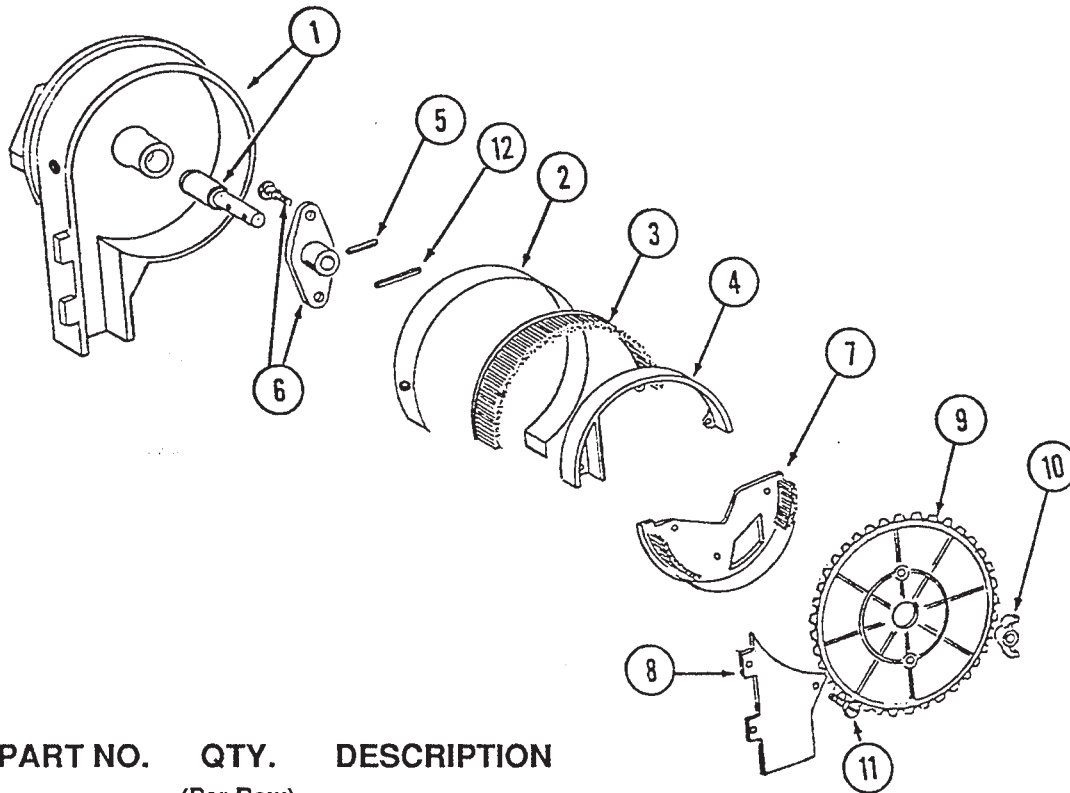

ITEM	PART NO.	QTY. (Per Row)	DESCRIPTION
1.	GA6027	1	Housing W/Bearing
	GA5698	-	Bearing
2.	GD8778	1	Wear Strip
3.	GA5699	1	Retaining Brush
4.	GD8237	1	Upper Brush Holder
5.	G10603	1	Spring Pin, 1/4" x 1 1/4"
6.	GA6038	1	Hub W/Shoulder Bolts
	GD1755	-	Shoulder Bolt, 1/4" (2 Used)
7.	GA5834	1	Lower Brush Holder
8.	GD7878	1	Cover
9.	GA5794	-	Seed Disc, Soybean , 60 Cell, Black Color-coded
	GA6184	-	Seed Disc, Specialty Soybean, 48 Cell, Dark Blue Color-coded
	GA5982	-	Seed Disc, Small Milo/Grain Sorghum, 30 Cell, Red Color-coded
	GA6187	-	Seed Disc, Large Milo/Grain Sorghum, 30 Cell, Light Blue Color-coded
	GA5795	-	Seed Disc, High Rate Milo/Grain Sorghum, 60 Cell, Red Color-coded
	GA6633	-	Seed Disc, High Rate Large Milo/Grain Sorghum, 60 Cell, Yellow Color-Coded
	GA5796	-	Seed Disc, Cotton, Acid-delinted, 30 Cell, White Color-coded
	GA6168	-	Seed Disc, Large Cotton, Acid-delinted, 36 Cell, Tan Color-coded
	GA6478	-	Seed Disc, High Rate Cotton, Acid-delinted, 48 Cell, Light Green Color-coded
	GA6182	-	Seed Disc, Hill-drop Cotton, Acid-delinted, 12 Cell, Brown Color-coded
10.	G10531	2	Nylon Insert Wing Nut, 1/4"-20
11.	G10584	9	Slotted Tap Screw, No. 10-24 x 1/2"
12.	G10602	1	Spring Pin, 1/4" x 1 1/2"

GRANULAR CHEMICAL BANDERS

RUA013/RUA012/RUA016

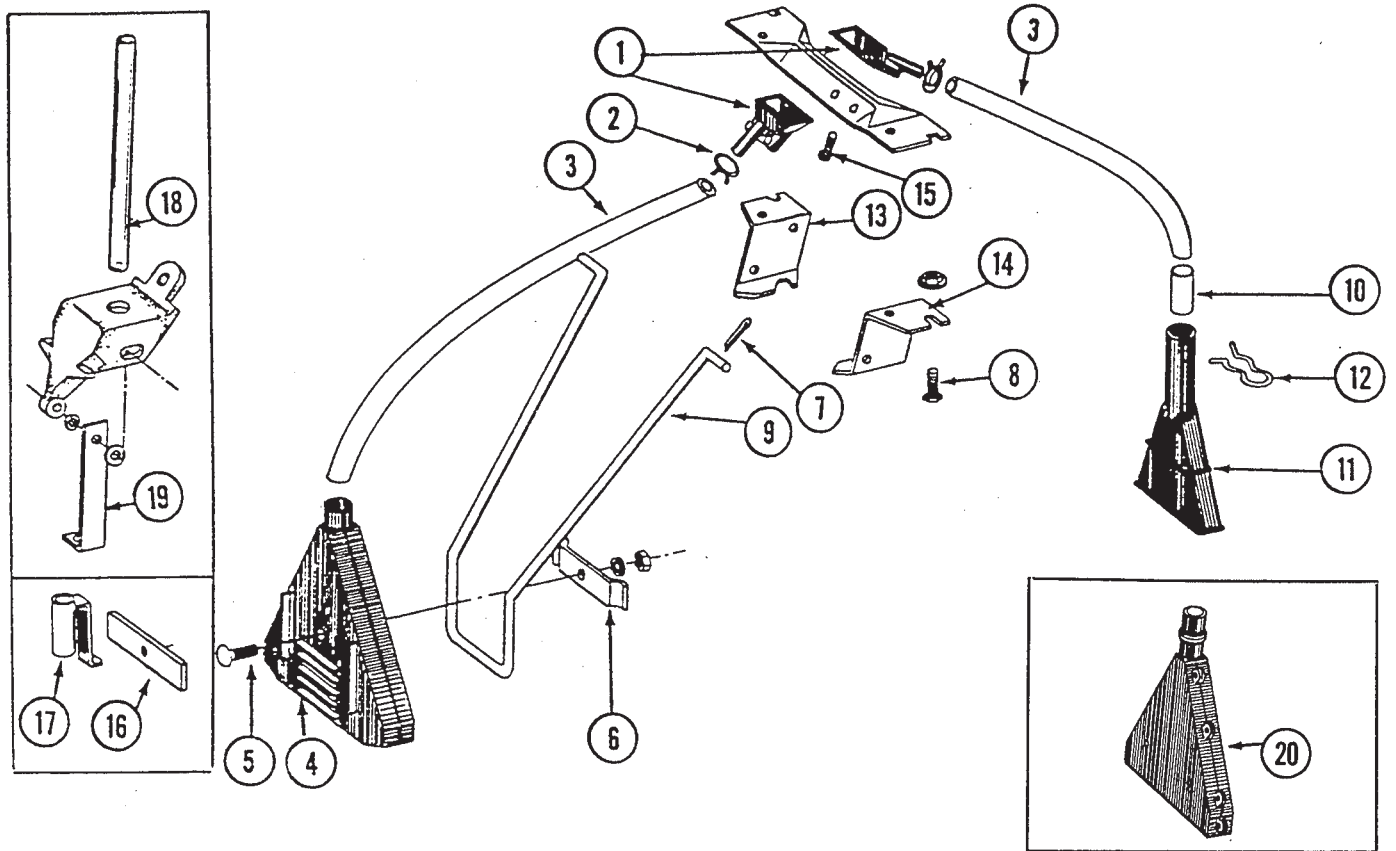

ITEM	PART NO.	QTY.	DESCRIPTION
1.	GD2423	-	Funnel
2.	G10680	-	Hose Clamp, 7/16"
3.	GD1128	-	Hose, 7/16" x 18"
4.	GA2075	-	Diffuser, 14" Band
5.	G10306	-	Carriage Bolt, 3/8"-16 x 2", Grade 2
	G10229	-	Lock Washer, 3/8"
	G10101	-	Hex Nut, 3/8"-16
6.	GD1118	-	Clamp
7.	G10452	-	Cotter Pin, 1/8" x 1/2"
8.	G10310	-	Carriage Bolt, 1/4"-20 x 3/4", Grade 2
	G10227	-	Lock Washer, 1/4"
	G10103	-	Hex Nut, 1/4"-20
9.	GD1116	-	Hanger
10.	GD1082	-	Tube
11.	GD1081	-	Spreader, 7" Band
12.	GD1090	-	Spring Clip
13.	GD1115L	-	Hanger Bracket, L.H.
14.	GD1115R	-	Hanger Bracket, R.H.
15.	G10523	-	Self Tapping Screw, No. 10 x 1/2"
16.	GD1323	-	Strap (Rear Mount)
17.	GA0485	-	Tube With Bracket (Rear Mount)
18.	GD2947	-	Hose, 7/16" x 28" (Direct Drop)
19.	GD2864	-	Bracket (Direct Drop)
20.	GA6476	-	Slope-compensating Spreader (3" or 7" Band)

GRANULAR CHEMICAL HOPPER WITH METER(S) & THROWOUT

RUA008/RUB005/RUB014/RUA033/RUA034/RUA006

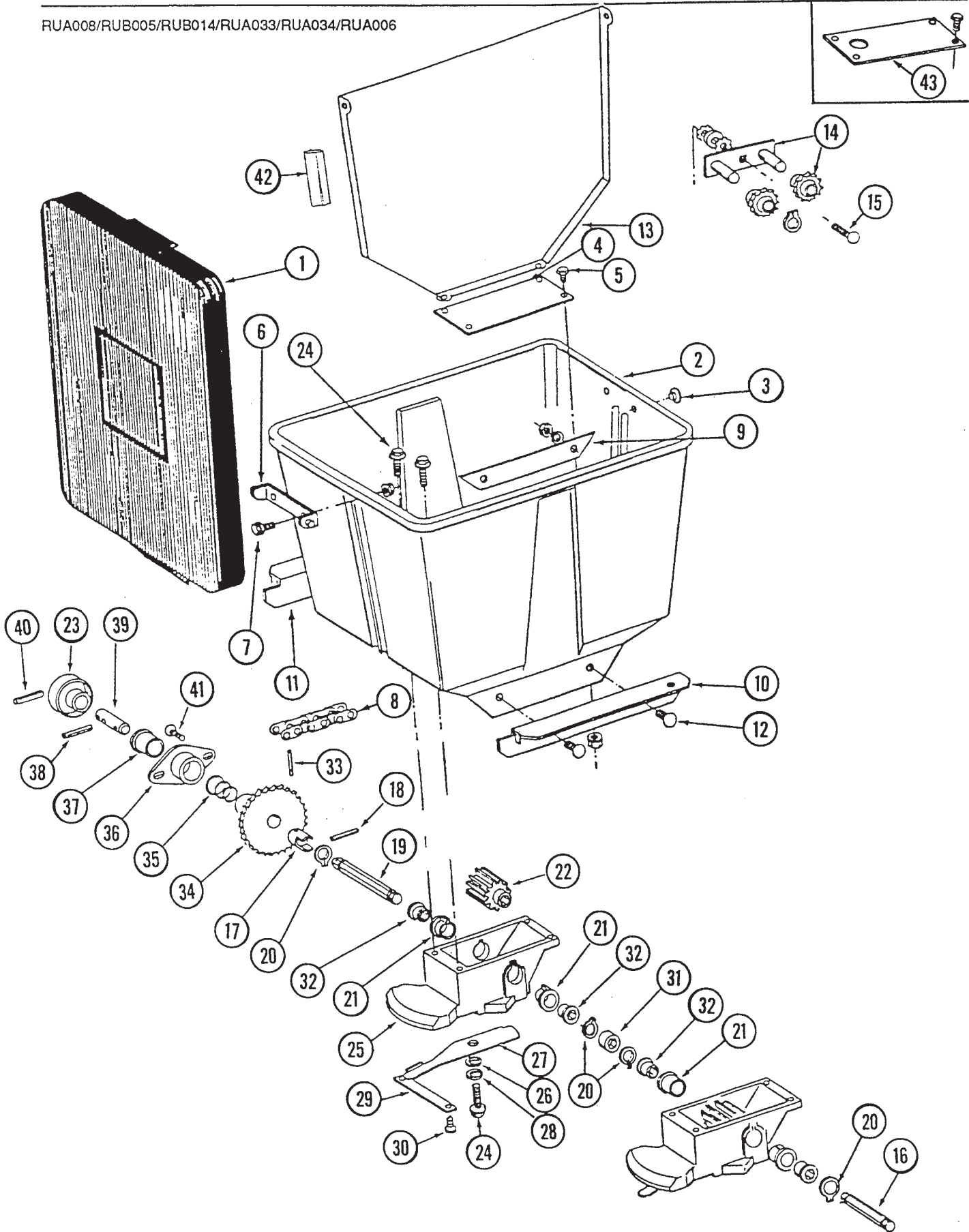

GRANULAR CHEMICAL HOPPER WITH METER(S) & THROWOUT

ITEM	PART NO.	QTY. (Per Row)	DESCRIPTION
1.	GA4444	1	Lid
2.	GD1058	1	Hopper
3.	GD1089	2	Plug
4.	GD1056	-	Cover Plate (1 Used With One Meter)
5.	G10022	4	Hex Head Cap Screw, 1/4"-20 x 1/2"
	G10621	4	Flange Nut, 1/4"-20
6.	GD1060	1	Hinge
7.	G10023	2	Hex Head Cap Screw, 1/4"-20 x 3/4"
	G10621	2	Flange Nut, 1/4"-20
8.	G3303-114	1	Roller Chain, No. 41, 114 Pitch Including Connector Link
	GR0196	1	Connector Link, No. 41
9.	GD1072	2	Strap
10.	GD1059R	1	Support, Right Hand
11.	GD1059L	1	Support, Left Hand
12.	G10311	4	Carriage Bolt, 3/8"-16 x 3/4" Short Necked, Grade 2
	G10229	4	Lock Washer, 3/8"
	G10101	4	Hex Nut, 3/8"-16
13.	GA2076	1	Divider (Used With Two Meters)
14.	GA2008	1	Idler Arm With Sprockets And Rings
	GD7426	-	Sprocket (2 Used)
	G10435	-	Ring (2 Used)
15.	G10305	1	Carriage Bolt, 3/8"-16 x 1", Grade 2
	G10524	2	Internal-External Lock Washer, 3/8"
	G10207	1	Washer, 3/8"
	G10229	1	Lock Washer, 3/8"
	G10101	1	Hex Nut, 3/8"-16
16.	GD7591	-	Shaft (1 Used On 2nd Meter)
17.	GB0184	1	Coupling
18.	G10546	1	Spring Pin, 3/16" x 1 1/4"
19.	GD7588	1	Shaft
20.	G10567	1	Retaining Ring
21.	GB0115	-	Bearing (2 Used Per Meter)
22.	GD7148	-	Feed Roller, Hex Bore (1 Used Per Meter)
23.	GD7587	1	Knob
24.	G10570	-	Self Tapping Screw, 1/4" x 3/4" (1 Used Per Meter)
25.	GB0116	-	Granular Housing (1 Used Per Meter)
26.	G10660	-	Wave Washer (1 Used Per Meter)
27.	GD1063	-	Metering Gate (1 Used Per Meter)
28.	G10209	-	Washer, 1/4" USS (1 Used Per Meter)
29.	GD1061	-	Support Strap (1 Used Per Meter)
30.	G10521	1	Self Tapping Screw, No. 10 x 3/8" (2 Per Meter)
31.	GD7592	1	Coupler, Hex Bore (With 2nd Meter)
32.	GD7258	-	Hex Bushing (2 Per Meter)
33.	G10609	1	Spring Pin, 5/32" x 1"
34.	GA5533	1	Sprocket, 24 Tooth
35.	GD8458	1	Spring
36.	GB0183	1	Bearing Mount
37.	GB0121	1	Bearing
38.	G10602	1	Spring Pin, 1/4" x 1 1/2"
39.	GD7589	1	Throwout Pin
40.	G10637	1	Spring Pin, 1/8" x 1 1/2"
41.	G10312	2	Carriage Bolt, 5/16"-18 x 3/4"
	G10620	2	Flange Nut, 5/16"-18
42.	G3314-40	-	Foam Strip, 40"
43.	GD8750	-	Restrictor Plate (Optional)

NO TILL COULTER, ROW UNIT MOUNTED

(Plateless Row Unit & Interplant Push Row Unit)

RUA036

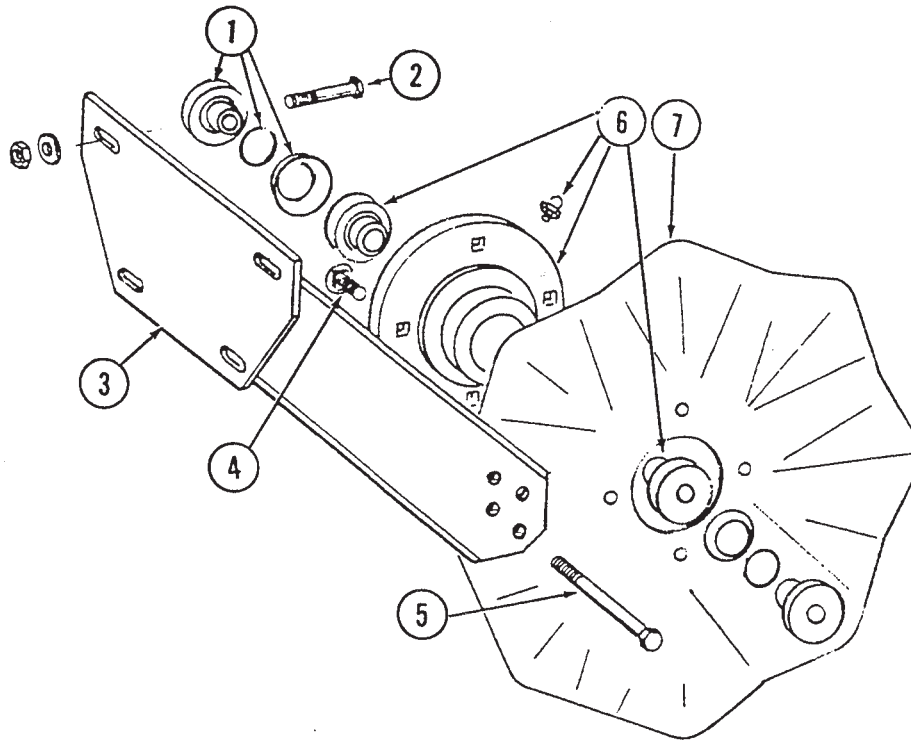

ITEM	PART NO.	QTY.	DESCRIPTION
		(Per Row)	
1.	GB0227	2	Adapter W/O-Ring And Spring Washer
	GD8844	2	O-Ring
	GD8843	2	Spring Washer
2.	G10574	4	Carriage Bolt, 1/2"-13 x 1 1/4"
	G10216	4	Washer, 1/2" USS
	G10111	4	Lock Nut, 1/2"-13
3.	GA5625	1	Arm
4.	G10574	4	Carriage Bolt, 1/2"-13 x 1 1/4"
	G10111	4	Lock Nut, 1/2"-13
5.	G10036	1	Hex Head Cap Screw, 5/8"-11 x 4"
	G10107	1	Lock Nut, 5/8"-11
6.	GA5640	1	Hub W/Bearings And Grease Fitting
	GA5622	-	Bearing (2 used)
	G10640	1	Grease Fitting, 1/4"-20
7.	GD7803	-	Fluted Blade, 1" (Shown)
	GD7804	-	Rippled Blade, 1"
	GD9254	-	Fluted Blade, 3/4"

DISC FURROWER, ROW UNIT MOUNTED

RUA038

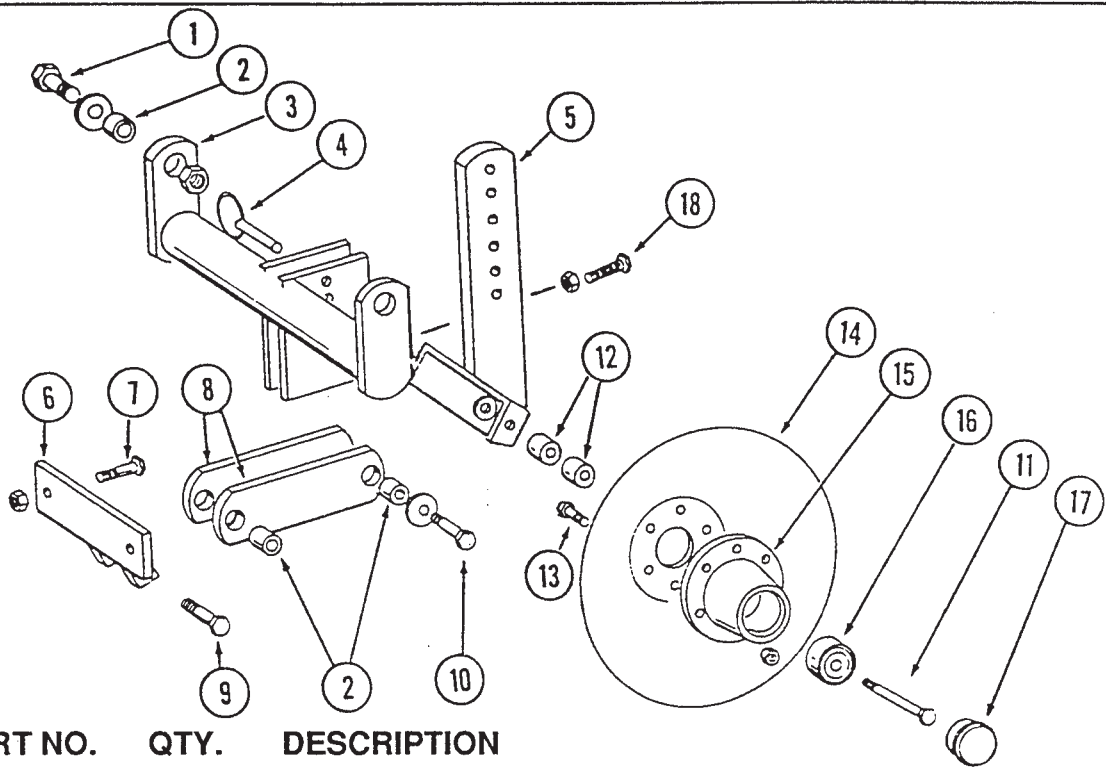

ITEM	PART NO.	QTY. (Per Row)	DESCRIPTION	
1.	G10039	2	Hex Head Cap Screw, 1/2"-13 x 1 3/4"	
	G10216	2	Washer, 1/2" USS	
	G10111	2	Lock Nut, 1/2"-13	
2.	GD7889	6	Bushing	
3.	GA5719	1	Mounting Bracket	
4.	G10536	1	Pin	
5.	GA5718	1	Support Arm	
6.	GA5715	1	Anchor	
	7.	G10017	2	Hex Head Cap Screw, 1/2"-13 x 1 1/2"
		G10111	2	Lock Nut, 1/2"-13
8.	GD7890	2	Link	
9.	G10017	2	Hex Head Cap Screw, 1/2"-13 x 1 1/2"	
	G10216	2	Washer, 1/2" USS	
	G10111	2	Lock Nut, 1/2"-13	
10.	G10585	1	Hex Head Cap Screw, 1/2"-13 x 3 1/4"	
	G10216	2	Washer, 1/2" USS	
	G10111	1	Lock Nut, 1/2"-13	
11.	G10318	2	Hex Head Cap Screw, 5/8"-11 x 4 1/2"	
	GD7805	2	Special Washer	
	G10107	2	Lock Nut, 5/8"-11	
12.	GD7817-01	2	Spacer, 3/4"	
	GD7817-04	2	Spacer, 1/2"	
13.	G10572	6	Truss Head Slotted Machine Screw, 5/16"-18 x 7/8"	
	G10106	6	Hex Nut, 5/16"-18	
14.	GD7823	-	Solid Disc, 12" (Shown)	
	GD8307	-	Notched Disc, 12"	
15.	GB0195	2	Hub	
16.	GA2014	4	Bearing	
17.	GD1132	2	Dust Cap	
18.	G10503	1	Jam Nut, 5/8"-11	
	G10597	1	Set Screw, 5/8"-11 x 2 1/4"	

FRAME MOUNTED COULTER W/DISC FURROWER

RUA035

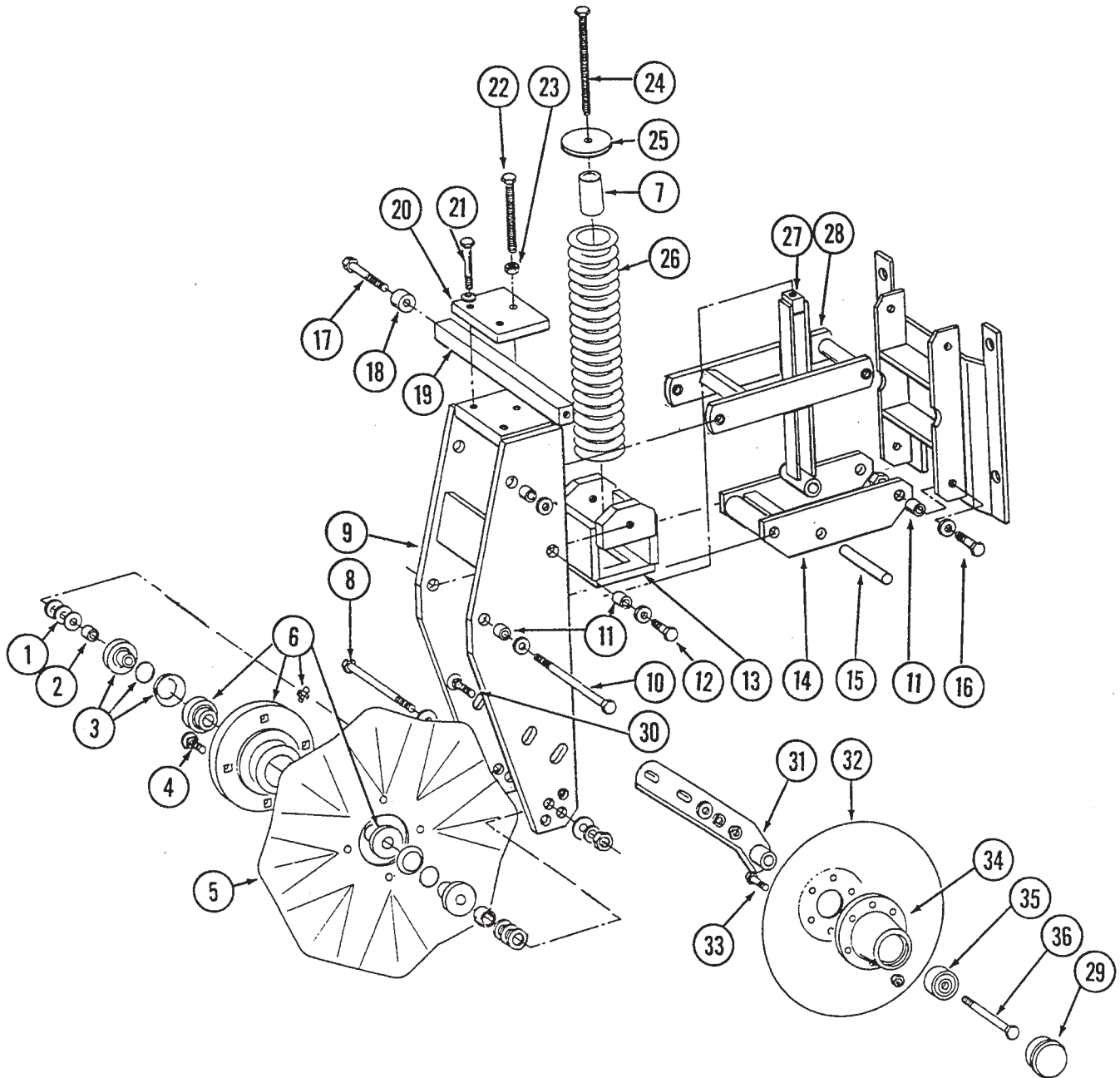

FRAME MOUNTED COULTER W/DISC FURROWER

ITEM	PART NO.	QTY. (Per Row)	DESCRIPTION
1.	G10217	-	Washer, 5/8" USS (As Required)
2.	GD7817-04	2	Spacer, 1/2"
3.	GB0227	2	Adapter W/O-Ring And Spring Washer
	GD8844	-	O-Ring
	GD8843	-	Spring Washer
4.	G10574	4	Carriage Bolt, 1/2"-13 x 1 1/4"
	G10111	4	Lock Nut, 1/2"-13
5.	GD7803	-	Fluted Blade, 1" (Shown)
	GD7804	-	Rippled Blade, 1"
	GD9254	-	Fluted Blade, 3/4"
6.	GA5640	1	Hub W/Bearings And Grease Fitting
	GA5622	-	Bearing (2 used per hub)
	G10640	-	Grease Fitting, 1/4"-20
7.	GD7817-09	1	Stop, 1 3/4"
8.	G10068	1	Hex Head Cap Screw, 5/8"-11 x 6"
	G10107	1	Lock Nut, 5/8"-11
9.	GA5643	1	Fork Mount
10.	G10012	1	Hex Head Cap Screw, 5/8"-11 x 6 1/2"
	GD7805	2	Washer
	G10107	1	Lock Nut, 5/8"-11
11.	GB0218	10	Bushing
12.	G10055	2	Hex Head Cap Screw, 5/8"-11 x 1 1/4"
	GD7805	2	Washer
13.	GA5637	1	Spring Socket
14.	GA5631	1	Lower Parallel Link
15.	GD7815	1	Pin, 5/8" x 4 1/4"
16.	G10008	6	Hex Head Cap Screw, 5/8"-11 x 2"
	GD7805	6	Washer
	G10107	6	Lock Nut, 5/8"-11
17.	GD7818	2	Special Bolt
18.	GD7817-01	2	Roller, 3/4"
19.	GD7816	1	Depth Control Bar
20.	GD7811	1	Depth Adjustment Clamp
21.	G10581	2	Hex Head Cap Screw, 1/2"-13 x 2 1/4"
	G10228	2	Lock Washer, 1/2"
22.	G10582	1	Hex Head Cap Screw, 5/8"-11 x 4", Full Thread
23.	G10104	1	Hex Nut, 5/8"-11
24.	G10573	1	Hex Head Cap Screw, 5/8"-11 x 5 1/2", Full Thread
25.	GB0196	1	Washer
26.	GD7831	1	Compression Spring
27.	GA5635	1	Spring Guide
28.	GA5630	1	Upper Parallel Link
29.	GD1132	2	Dust Cap
30.	G10197	4	Carriage Bolt, 1/2"-13 x 2"
	G10206	-	Washer, 1/2" SAE (As required)
	G10228	4	Lock Washer, 1/2"
	G10102	4	Hex Nut, 1/2"-13
31.	GA5636	2	Arm
32.	GD7823	-	Solid Disc, 12" (Shown)
	GD8307	-	Notched Disc, 12"
33.	G10572	12	Truss Head Slotted Machine Screw, 5/16"-18 x 7/8"
	G10106	12	Hex Nut, 5/16"-18
34.	GB0195	2	Hub
35.	GA2014	4	Bearing
36.	G10036	2	Hex Head Cap Screw, 5/8"-11 x 4"
	G10107	2	Lock Nut, 5/8"-11

SPRING TOOTH INCORPORATOR

RUA011

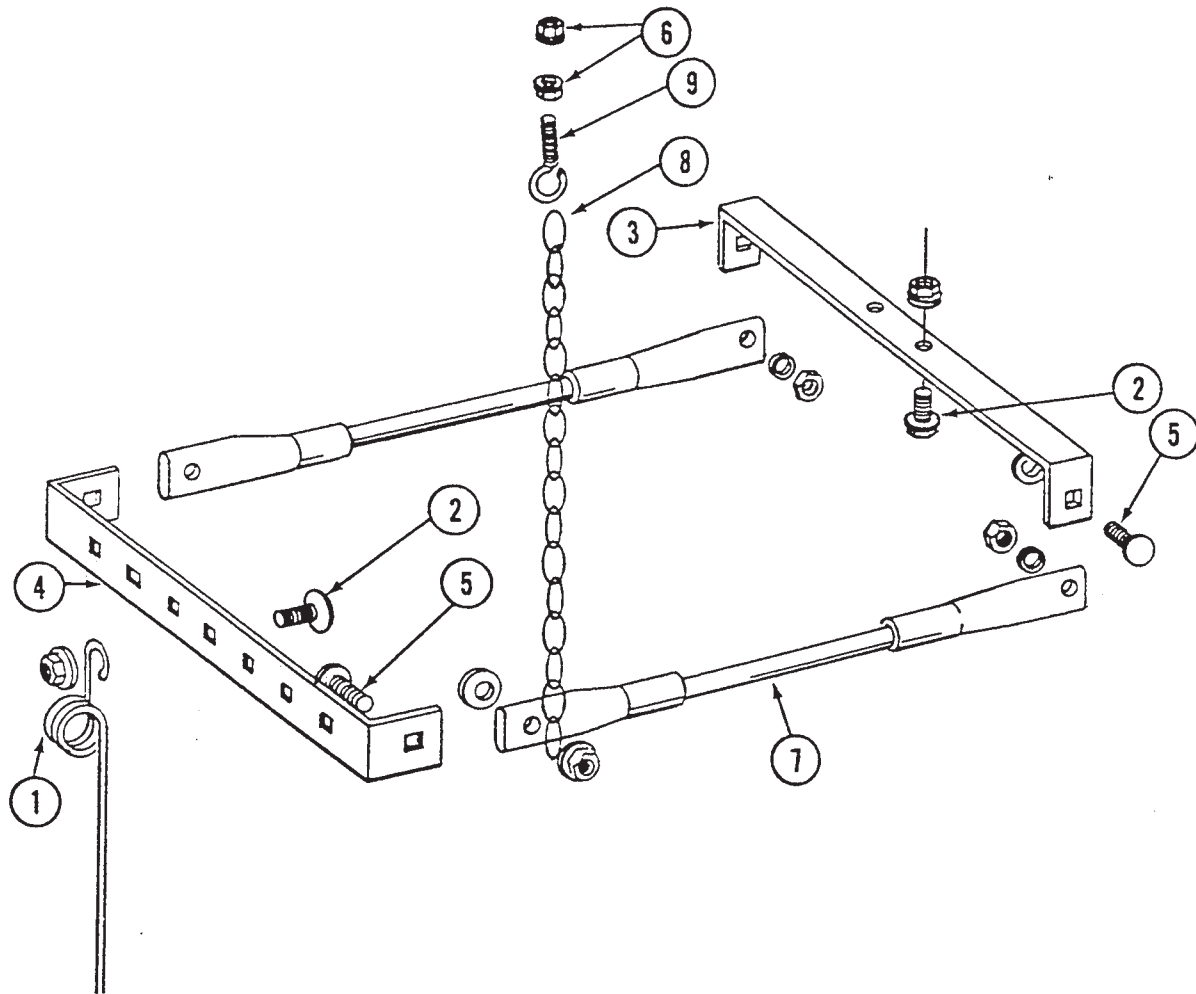

SPRING TOOTH INCORPORATOR

ITEM	PART NO.	QTY. (Per Row)	DESCRIPTION
1.	GD1145	7	Spring Tooth
2.	G10308	9	Carriage Bolt, 3/8"-16 x 3/4", Grade 2
	G10622	9	Flange Lock Nut, 3/8"-16
3.	GD1143	1	Front Bracket
4.	GD1144	1	Rear Bracket
5.	G10305	4	Carriage Bolt, 3/8"-16 x 1", Grade 2
	G10529	4	External Tooth Lock Washer, 3/8"
	G10622	4	Flange Lock Nut, 3/8"-16
6.	G10621	4	Flange Lock Nut, 1/4"-20
7.	GA2094	2	Cable Assembly
8.	G3305-01	4	Chain
9.	GD2460	2	Eyebolt, 1/4"-20

INTERPLANT PUSH UNIT

RPU001/RPU009

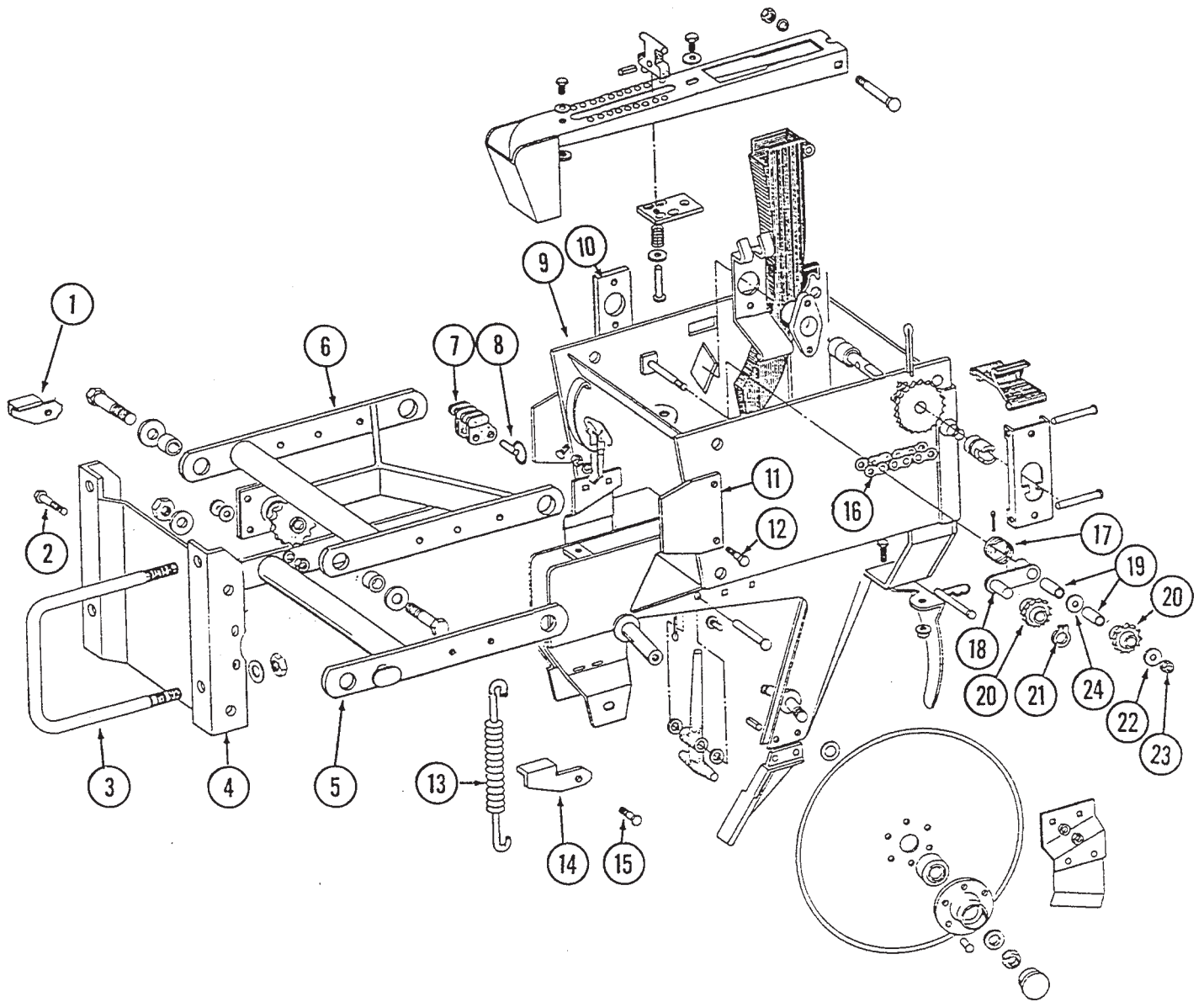

INTERPLANT PUSH UNIT

ITEM	PART NO.	QTY. (Per Row)	DESCRIPTION
1.	GD7627	1	Lockup, L.H.
2.	G10004	2	Hex Head Cap Screw, 3/8"-16 x 1 1/4"
	G10210	-	Washer, 3/8" USS (As Required)
	G10229	2	Lock Washer, 3/8"
	G10101	2	Hex Nut, 3/8"-16
3.	GD1113	2	U-Bolt, 5" x 7" x 5/8"-11
	G10230	4	Lock Washer, 5/8"
	G10104	4	Hex Nut, 5/8"-11
4.	GA5786	1	Mounting Plate
5.	GA5787	1	Lower Arm
6.	GA5788	1	Upper Arm
7.	GB0186	2	Spring Anchor
8.	G10545	2	Detent Pin, 1" Grip
9.	GA5846	1	Shank Assembly
10.	GD2128	1	Plate
11.	GD6161	2	Stop Bar
12.	G10036	4	Hex Head Cap Screw, 1/2"-13 x 2"
	G10216	4	Washer, 1/2" USS
	G10102	4	Hex Nut, 1/2"-13
13.	GD8249	-	Spring
14.	GD7626	1	Lockup, R.H.
15.	G10017	2	Hex Head Cap Screw, 1/2"-13 x 1 1/2"
	G10228	2	Lock Washer, 1/2"
	G10111	2	Lock Nut, 1/2"-13
16.	G3303-96	1	Roller Chain, No. 41, 96 Links Including Connector Link
	GR0196	1	Connector Link, No. 41
17.	GD2134	1	Idler Spring
18.	GA2056	1	Idler Arm
19.	GD1026	2	Spacer
20.	GD7426	2	Sprocket
21.	G10435	1	Retaining Ring
22.	G10210	1	Washer, 3/8" USS
23.	G10108	1	Lock Nut, 3/8"-16
24.	G10384	1	Special Washer, 3/8"
A.	GA5564	-	Lockup Package, Includes: (1) GD7627, (1) GD7626, (2) G10228, (2) G10017, (2) G10111

INNER HITCH

PHA021/PHA025

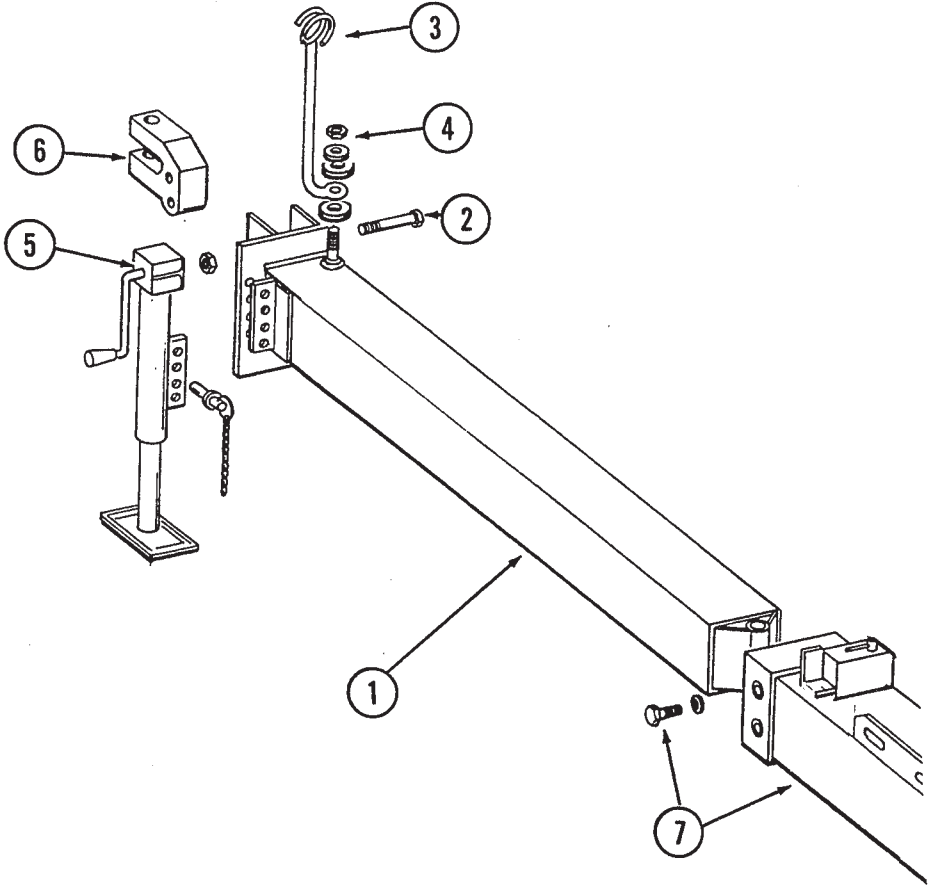

INNER HITCH

ITEM	PART NO.	QTY.	DESCRIPTION
1.		1	Inner Hitch, 65 1/4" (Non-stock Item)
2.	G10417	2	Hex Head Cap Screw, 7/8"-9 x 4 1/2"
	G10418	2	Lock Nut, 7/8"-9
3.	GD7140	1	Hose Holder
4.	G10217	2	Special Washer
	G10230	1	Lock Washer, 5/8"
	G10104	1	Hex Nut, 5/8"-11
5.	GA4994	1	Jack Assembly Complete
	GA4995	-	Detent Pin Assembly
	GR0517	-	Pin
	GR0516	-	Crank Assembly
	GR0515	-	Bevel Gear
6.	GB0181	1	Clevis
7.		-	See "Outer Hitch"

OUTER HITCH

PHA028

8 Row Shown

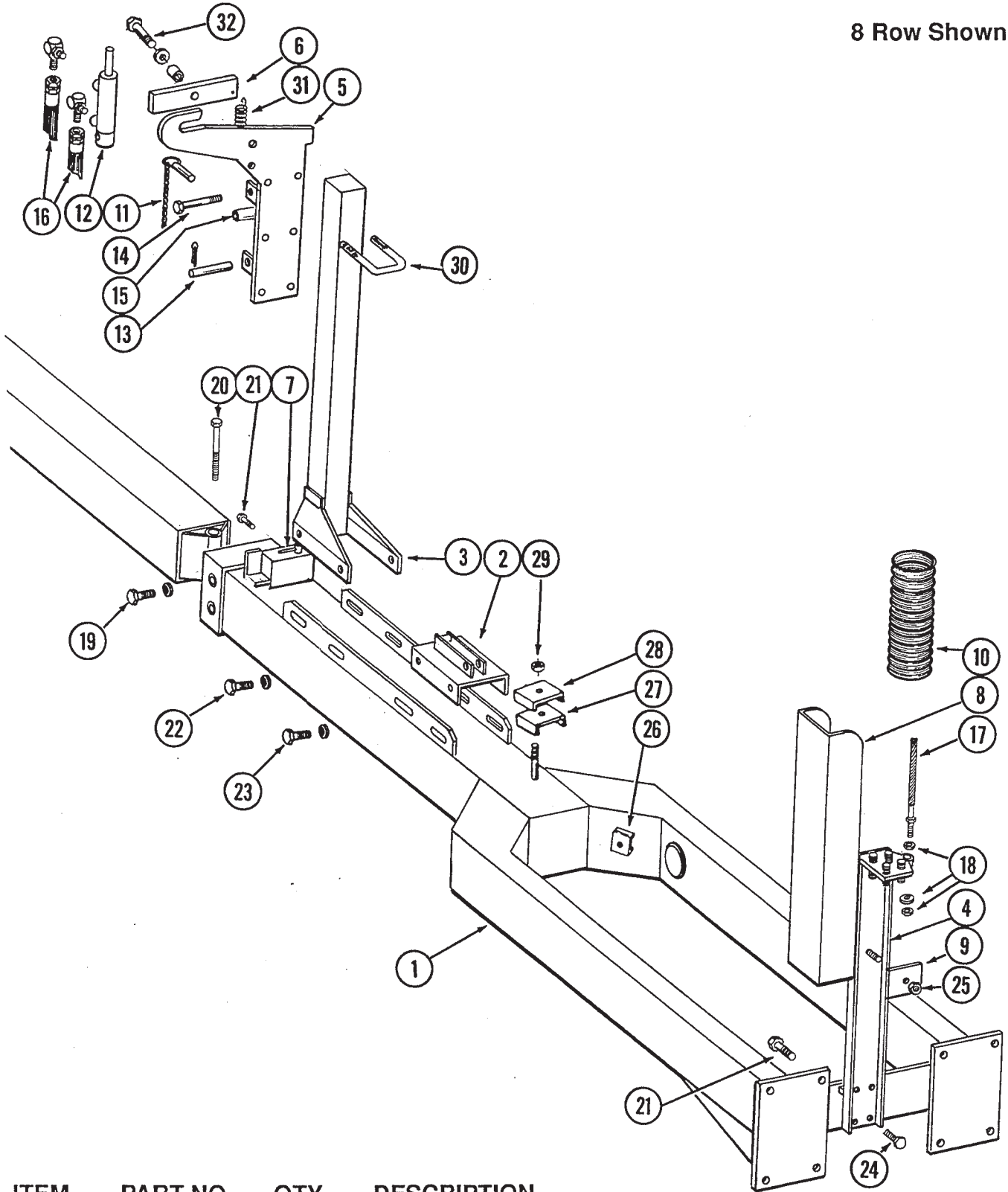

ITEM	PART NO.	QTY.	DESCRIPTION
1.		1	Outer Hitch, 125 1/2" (Non-stock Item)
2.	GA6404	1	Jack Storage Mount
3.	GA6623	-	Transport Post, 6 Row 30
	GA6418	-	Transport Post, 8 Row 30 (Shown)

OUTER HITCH

ITEM	PART NO.	QTY.	DESCRIPTION
4.	GA6402	1	Hose Support
5.	GA6420	1	Transport Catch
6.	GA6422	1	Catch Bar
7.		-	See "Selector Valve"
8.	GD9227	1	Channel
9.	GD9046	1	Hose Clamp
10.	GD9129-01	1	Hose Protector, 48"
11.	GA6498	1	Detent Pin
12.		-	See "Kickout Cylinder"
13.	GD7137	1	Pin, 3/4" x 3 1/4"
	G10457	2	Cotter Pin, 5/32" x 1 1/2"
14.	G10061	1	Hex Head Cap Screw, 3/8"-16 x 3 1/2"
	G10229	1	Lock Washer, 3/8"
	G10101	1	Hex Nut, 3/8"-16
15.	GD2971-09	1	Sleeve, 5/8" O.D. x 2"
	GD3180-03	-	Sleeve, 7/8" O.D. x 15/16" (As Required)
16.		-	See "Hydraulic System"
17.	GA6608	1	Cable Assembly
18.	G10228	4	Lock Washer, 1/2"
	G10102	4	Hex Nut, 1/2"-13
19.	G10716	2	Hex Head Cap Screw, 3/4"-10 x 1"
	G10231	2	Lock Washer, 3/4"
20.	G10717	1	Hex Head Cap Screw, 1 1/4"-7 x 9"
	G10236	1	Lock Washer, 1 1/4"
	G10239	1	Hex Nut, 1 1/4"-7
21.	G10027	8	Hex Head Cap Screw, 3/4"-10 x 2 1/2", Grade 5
	G10231	8	Lock Washer, 3/4"
	G10105	8	Hex Nut, 3/4"-10
22.	G10005	4	Hex Head Cap Screw, 5/8"-11 x 1 3/4"
	GD7805	4	Special Washer
	G10230	4	Lock Washer, 5/8"
	G10104	4	Hex Nut, 5/8"-11
23.	G10005	4	Hex Head Cap Screw, 5/8"-11 x 1 3/4"
	G10205	4	Washer, 5/8" SAE
	G10230	4	Lock Washer, 5/8"
	G10104	4	Hex Nut, 5/8"-11
24.	G10004	4	Hex Head Cap Screw, 3/8"-16 x 1 1/4"
	G10229	4	Lock Washer, 3/8"
	G10101	4	Hex Nut, 3/8"-16
25.	G10048	1	Hex Head Cap Screw, 3/8"-16 x 2"
	G10229	1	Lock Washer, 3/8"
	G10101	1	Hex Nut, 3/8"-16
26.	GD5875	3	Hose Clamp
27.	GD0740	2	Hose Clamp
28.	GD5892	2	Hose Clamp
29.	G10108	1	Lock Nut, 3/8"-16
30.	GD4743	3	U-Bolt, 3" x 3" x 1/2"-13
	G10228	6	Lock Washer, 1/2"
	G10102	6	Hex Nut, 1/2"-13
31.	GD5857	1	Spring
32.	G10006	1	Hex Head Cap Screw, 5/8"-11 x 2 1/4"
	GD7805	1	Special Washer
	GB0218	1	Bushing
	G10107	1	Lock Nut, 5/8"-11

FRAME ASSEMBLY

PFA054

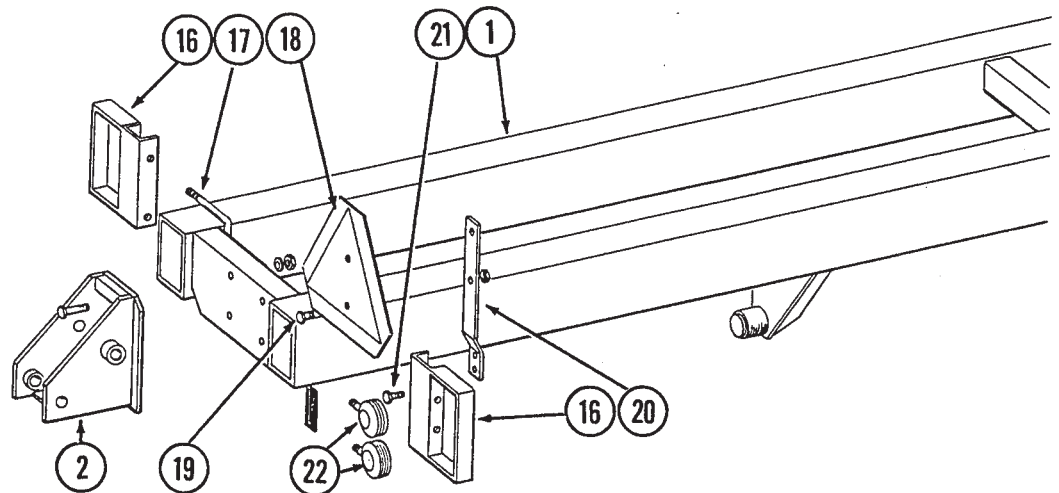

ITEM	PART NO.	QTY.	DESCRIPTION
1.		-	Frame, 180", 6 Row 30 (Non-stock Item)
		-	Frame, 240", 8 Row 30 (Non-stock Item)
2.		-	See "Marker Assembly"
3.	GD9093	16	Poly Wear Pad
4.	GB0234	16	Adjustment Pad
5.	GB0230	16	Cap
6.	G10025	2	Hex Head Cap Screw, 3/4"-10 x 1 1/2"
	G10231	2	Lock Washer, 3/4"
7.	GD9052	2	Washer
8.	GA6440	2	Sleeve W/Bronze Bushing
	GD9143	-	Bronze Bushing
9.	GA6497	2	Cam Follower W/Grease Fitting
	G10640	-	Grease Fitting, 1/4"-20
10.		-	See "Lift Cylinder"
11.		-	See "Hydraulic System"
12.		-	See "Marker Sequencing/Flow Control Valve"
13.	GR0375	1	Cylinder Pin
	GR0193	2	Hair Pin Clip
14.	GA5121	2	Pin
15.	G10037	2	Hex Head Cap Screw, 1/2"-13 x 1 1/4"
	G10228	2	Lock Washer, 1/2"
	G10102	2	Hex Nut, 1/2"-13

FRAME ASSEMBLY

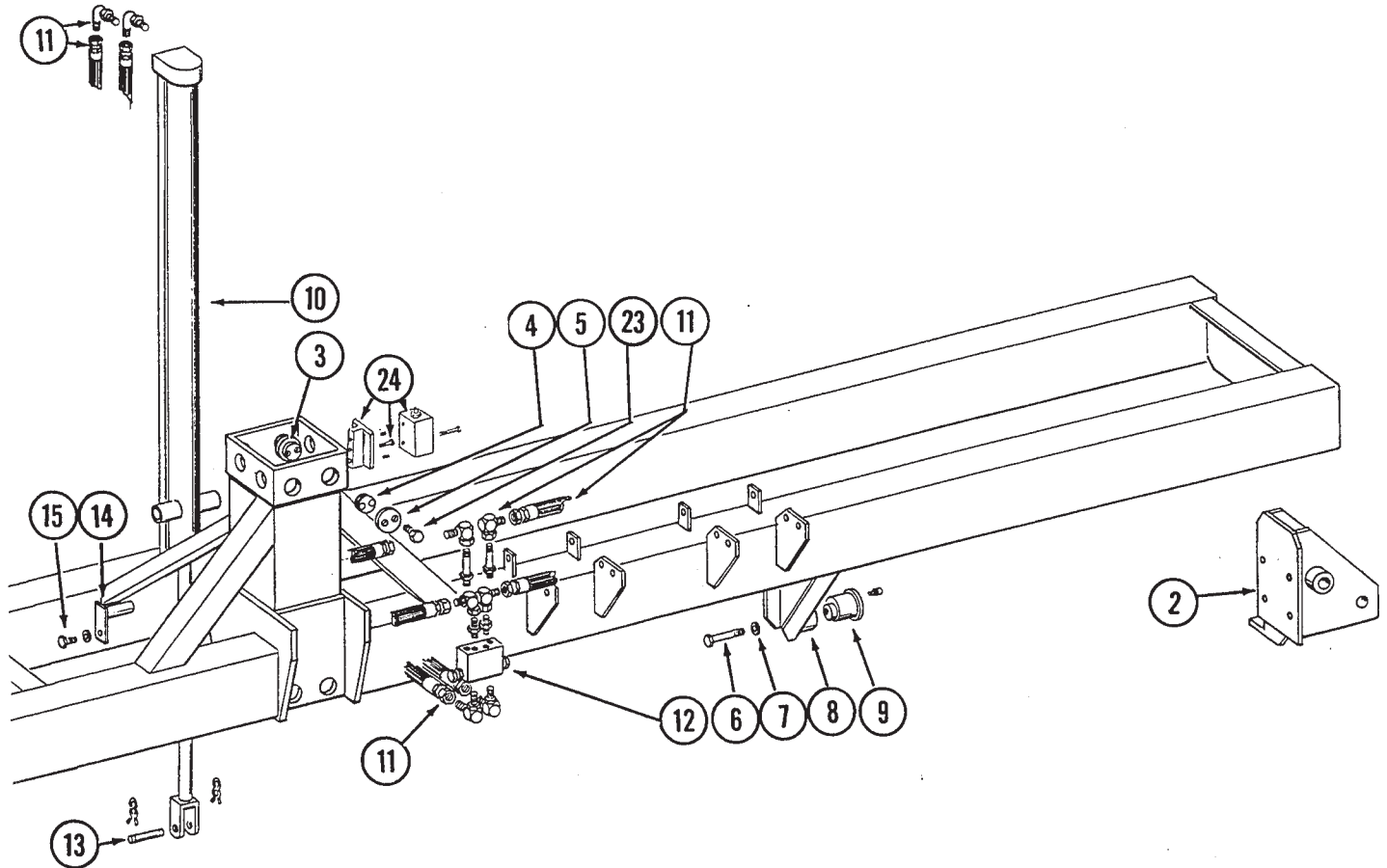

ITEM	PART NO.	QTY.	DESCRIPTION
16.	GA4431	2	Light Bracket
17.	GD1113	2	U-Bolt, 5" x 7" x 5/8"-11
	G10230	4	Lock Washer, 5/8"
	G10104	4	Hex Nut, 5/8"-11
18.	GD2199	1	SMV Sign
19.	G10022	2	Hex Head Cap Screw, 1/4"-20 x 1/2"
	G10227	2	Lock Washer, 1/4"
	G10103	2	Hex Nut, 1/4"-20
20.	GD6783	1	Bracket
21.	G10031	2	Hex Head Cap Screw, 5/16"-18 x 1 3/4"
	G10232	2	Lock Washer, 5/16"
	G10106	2	Hex Nut, 5/16"-18
22.	GA4122	2	Single Red Light Assembly Complete W/Female Terminal
	GA4123	2	Double Amber Light Assembly Complete W/Male Terminal
	GR0968	-	Bulb, No. 1156
	GR0970	-	Red Lens
	GR0969	-	Amber Lens
	G10289	-	Hex Nut, 1/2"-20
	G10525	-	Star Washer, 1/2"
		-	Rubber Washer (Non-stock Item)
	GR0971	-	O-Ring Gasket
	GR0972	-	Pigtail
	G10266	-	Female Terminal
	G10269	-	Male Terminal
23.	G10438	32	Hex Head Cap Screw, 1/2"-13 x 3/4"
24.		-	See "Axle/Pivot And Wheel Assembly"
A.	GA6398	-	Light Wiring Harness, 438" (Not Shown), 6 Row 30
	GA6397	-	Light Wiring Harness, 486" (Not Shown), 8 Row 30

AXLE/PIVOT AND WHEEL ASSEMBLY

PFA040/PLA015/HTA014

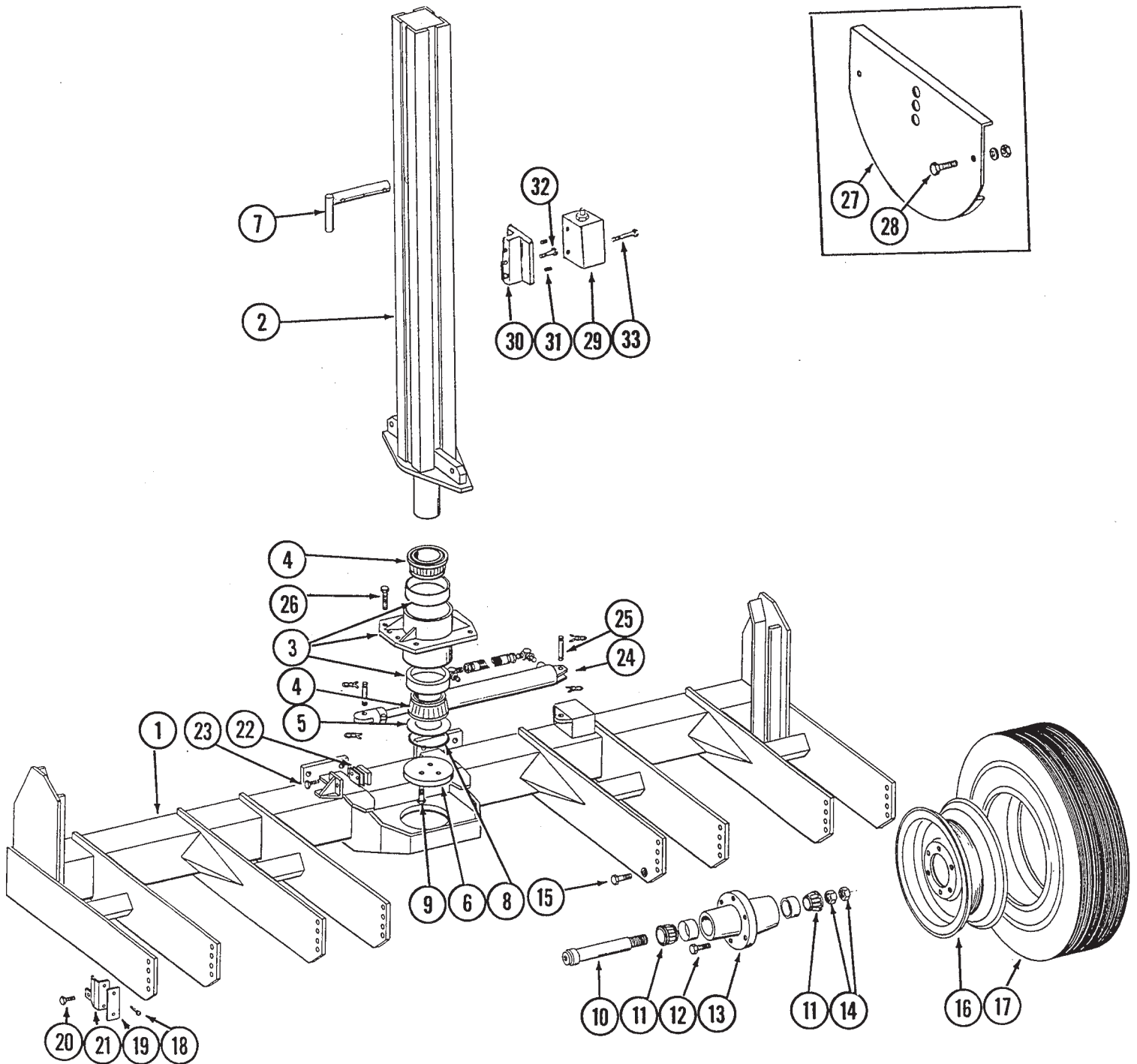

AXLE/PIVOT AND WHEEL ASSEMBLY

ITEM	PART NO.	QTY.	DESCRIPTION
		(Per Planter)	
1.		1	Axle (Non-stock Item)
2.	GA6360	1	Center Post
3.	GA6496	1	Bearing Housing W/Cups And Grease Fitting
	GD9121	-	Cup
	G10640	-	Grease Fitting, 1/4"-20
4.	GA6435	2	Cone
5.	GD9122	-	Shim, .005" thick (As Required)
	GD9123	-	Shim, .007" Thick (As Required)
	GD9124	-	Shim, .020" Thick (As Required)
6.	GD9051	1	Bearing Cap
7.	GA6849	1	Safety Lockup Pin, 11"
	G10671	1	Slotted Spring Pin, 3/16" x 3 1/4"
	G10606	1	Spring Pin, 1/4" x 2"
8.	GD9130	1	O-Ring
9.	G10008	3	Hex Head Cap Screw, 5/8"-11 x 2"
	G10230	3	Lock Washer, 5/8"
10.	GA4693	1	Spindle (Per Wheel)
11.	GA0895	2	Cone
12.	GR0270	6	Lug Bolt, 9/16"-12
13.	GA2148	1	Hub W/Cups, 6 Bolt
	GR0434	-	Cup
14.	G10087	2	Jam Nut, 1 1/2"-10
15.	G10026	2	Hex Head Cap Screw, 3/4"-10 x 2"
	G10231	2	Lock Washer, 3/4"
16.	GA2142	1	Rim W/Valve Protector, 20" x 5.50" (Per Wheel)
17.	GD6177	1	Tire, 7.50" x 20", Tube Type Less Tube, 6 Ply
	GD4167	1	Tube, 7.50" x 20"
18.	G10482	4	Slotted Screw, #8 x 3/4"
10.		-	See "Decals, Reflectors And Tie Straps"
20.	G10039	2	Hex Head Cap Screw, 1/2"-13 x 1 3/4"
	G10228	2	Lock Washer, 1/2"
	G10102	2	Hex Nut, 1/2"-13
21.	GD6957	1	Mount, L.H. (Shown)
	GD6958	1	Mount, R.H.
22.	GD3389	1	Tap Block
	GD3398	-	Shim, 16 Gauge (As Required)
	GD7888	-	Shim, 22 Gauge (As Required)
23.	G10016	2	Hex Head Cap Screw, 1/2"-13 x 2"
	G10228	2	Lock Washer, 1/2"
24.		-	See "Rotation Cylinder"
25.	GR0375	2	Cylinder Pin
	GR0193	4	Hair Pin Clip
26.	G10028	8	Hex Head Cap Screw, 3/4"-10 x 3"
	G10231	8	Lock Washer, 3/4"
	G10105	8	Hex Nut, 3/4"-10
27.	GA6529	-	Rock Guard (Optional)
28.	G10037	-	Hex Head Cap Screw, 1/2"-13 x 1 1/4"
	G10228	-	Lock Washer, 1/2"
	G10102	-	Hex Nut, 1/2"-13
29.		-	See "Stroke Limiter Valve"
30.	GA6850	1	Valve Mount
31.	G10120	2	Set Screw, 3/8" x 1/2"
32.	G10005	1	Hex Head Cap Screw, 5/8"-11 x 1 3/4"
33.	G10638	2	Hex Head Cap Screw, 1/4"-20 x 2"
	G10227	2	Lock Washer, 1/4"
A.	GA6428	-	Hub And Spindle Assembly (Items 10-15)

CONTACT DRIVE WHEEL AND ARM ASSEMBLY

PLA026

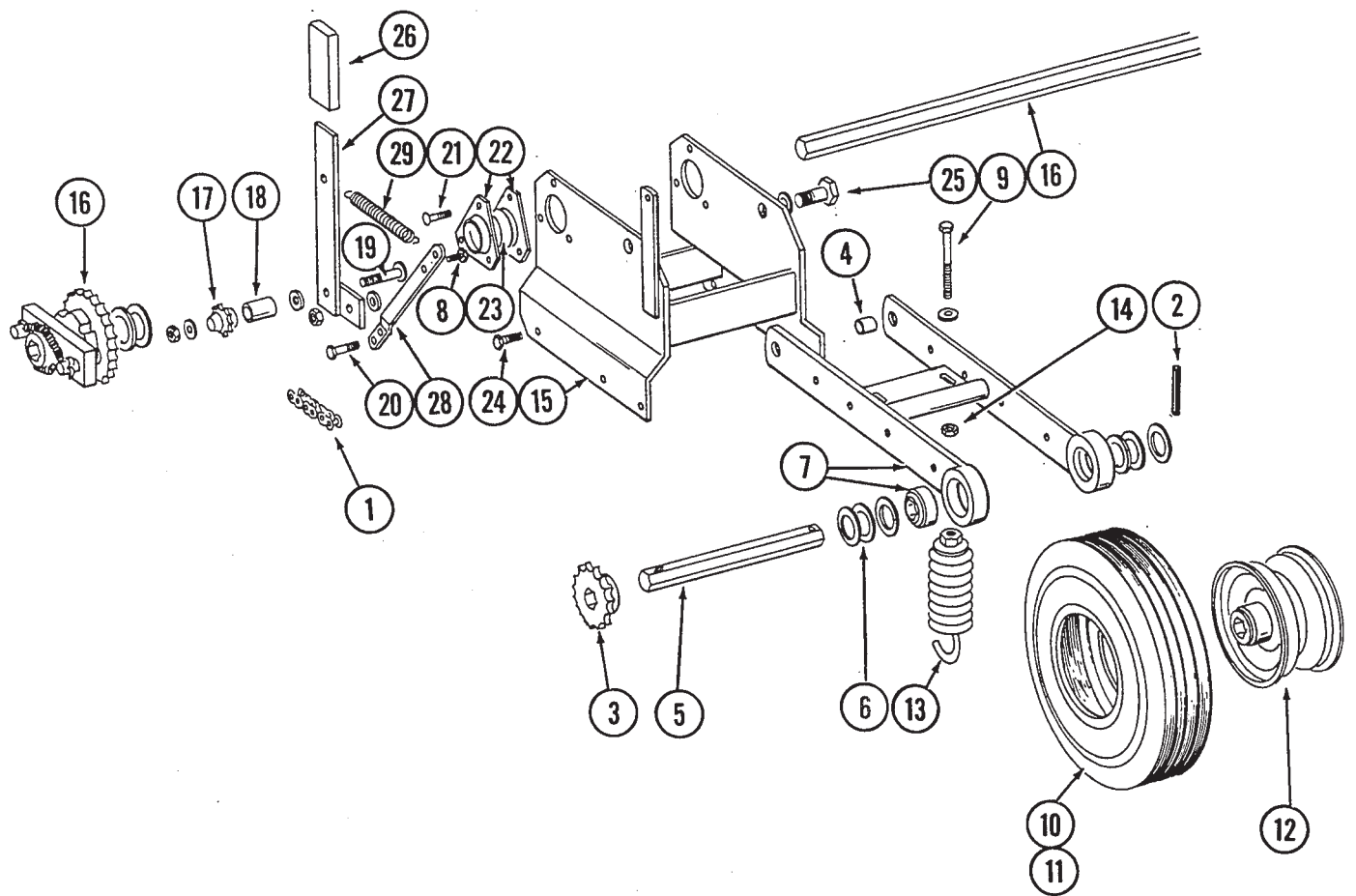

CONTACT DRIVE WHEEL AND ARM ASSEMBLY

ITEM	PART NO.	QTY.	DESCRIPTION
		(Per Wheel)	
1.	G3310-117	1	Chain, No. 40, 117 Pitch Including Connector Link And Offset Link
	GR0912	-	Connector Link, No. 40
	GR0911	-	Offset Link, NO. 40
2.	G10602	2	Spring Pin, 1/4" x 1 1/2"
3.	GA5105	1	Sprocket, 15 Tooth
4.	GB0218	2	Bushing
5.	GD5797	1	Shaft, 7/8" x 10"
6.	G10233	6	Machine Bushing, 1"
7.	GA6415	2	Wheel Arm W/Bearings
	GA5116	-	Bearing, 7/8" Hex Bore Cylindrical
8.	G10001	3	Hex Head Cap Screw, 3/8"-16 x 1"
	G10229	3	Lock Washer, 3/8"
	GD5756	3	Special Nut
9.	G10053	2	Hex Adjusting Bolt, 1/2"-13 x 2 1/2", Grade 5
	G10206	2	Washer, 1/2" SAE
10.	GD5753	1	Tire, 4.10" x 6"
11.	GD5752	2	Tube
12.	GA5089	1	Rim
13.	GA2068	2	Spring
14.	G10501	2	Jam Nut, 1/2"
15.	GA6417	1	Mount
16.		-	See "Drive Line"
17.	GD7426	1	Idler Sprocket, 12 Tooth
18.	GD1026	1	Sleeve
19.	G10306	1	Carriage Bolt, 3/8"-16 x 2"
	G10210	1	Washer, 3/8" USS
	G10108	1	Lock Nut, 3/8"-16
20.	G10023	1	Hex Head Cap Screw, 1/4"-20 x 3/4"
	G10227	1	Lock Washer, 1/4"
	G10103	1	Hex Nut, 1/4"-20
21.	G10312	3	Carriage Bolt, 5/16"-18 x 3/4"
	G10232	3	Lock Washer, 5/16"
	G10106	3	Hex Nut, 5/16"-18
22.	G3400-01	2	Flangette
23.	G2100-03	1	Bearing, 7/8" Hex Bore, Spherical
24.	G10001	6	Hex Head Cap Screw, 3/8"-16 x 1"
	G10229	6	Lock Washer, 3/8"
	G10101	6	Hex Nut, 3/8"-16
25.	G10005	2	Hex Head Cap Screw, 5/8"-11 x 1 3/4"
	G10235	2	Machine Bushing
	G10205	2	Washer, 5/8" SAE
	G10107	2	Lock Nut, 5/8"-11
26.	GD5827	1	Cover
27.	GA5157	1	Idler Arm
28.	GD5860	1	Bar
29.	GD5857	1	Spring
A.	GA5090	-	Tire And Rim Assembly, Includes: (1)GD5753, (1)GD5752, (1)GA5089

DRIVE LINE

PTD033/PLA026/PTD016/PTD066

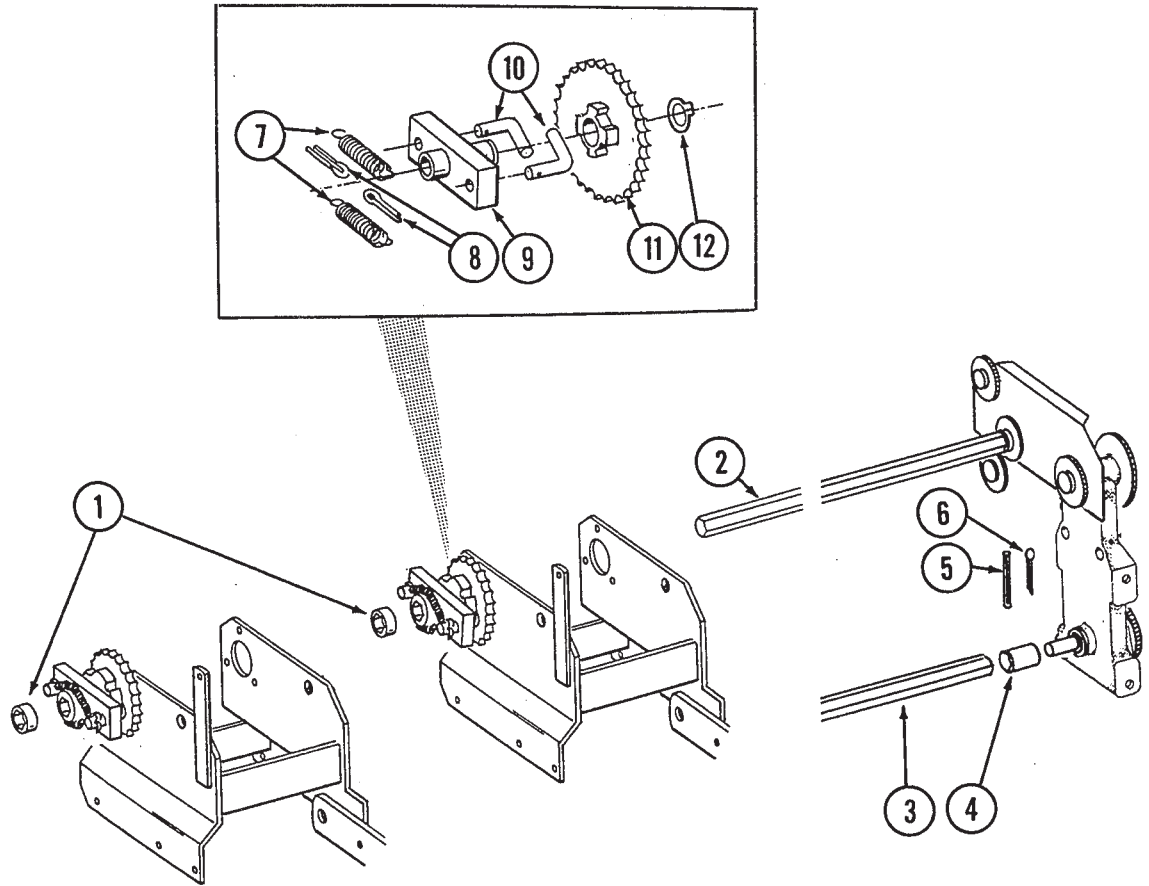

DRIVE LINE

ITEM	PART NO.	QTY.	DESCRIPTION
		(Per Planter)	
1.	GD0917	2	Lock Collar, Less Set Screws
	G10145	2	Set Screw, 5/16"-18 x 1/2"
2.	GD9078	-	Drive Shaft, 58" (4 holes), 6 Row 30
	GD9077	-	Drive Shaft, 98" (4 holes), 8 Row 30
3.	GD5887-165	-	Drill Shaft, 6 Row 30
	GD5887-225	-	Drill Shaft, 8 Row 30
4.	GD5886	1	Coupler
5.	G10602	1	Spring Pin, 1/4" x 2"
6.	G10460	1	Cotter Pin, 1/4" x 2"
7.	GD1256	4	Spring
8.	G10464	4	Cotter Pin, 3/16" x 1"
9.	GA0378	2	Block And Hub Assembly
10.	GD1255	4	"L" Pin
11.	GA5165	2	Hub/Sprocket Assembly, 30 Tooth
12.	G10430	2	Ring
A.	GA5164	-	Ratchet/Sprocket Assembly, Includes: (2)GD1256, (2)G10464, (1)GA0378, (2)GD1255, (1)GA5165, (1)G10430

TRANSMISSION ASSEMBLY

PTD040/PTD066/PTD041

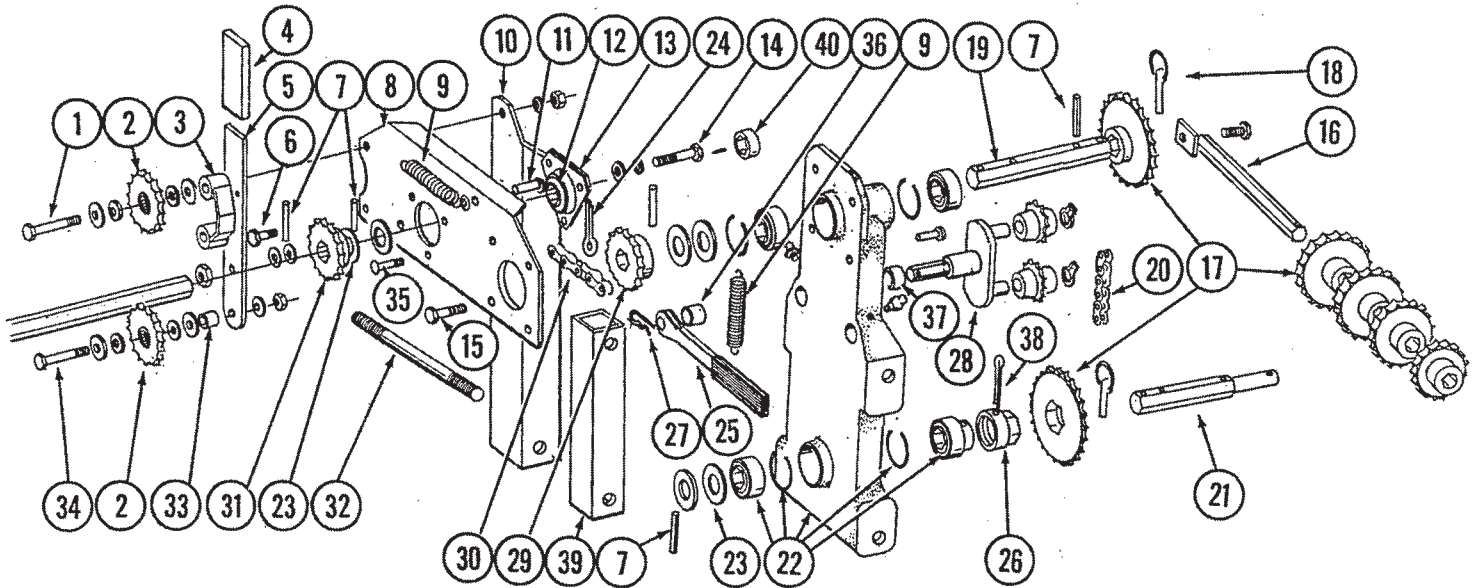

ITEM	PART NO.	QTY.	DESCRIPTION
1.	G10033	1	Hex Head Cap Screw, 1/2"-13 x 3 1/2"
	G10216	2	Washer, 1/2" USS (Large)
	G10128	1	Machine Bushing, 1/2" (Small)
	G10228	1	Lock Washer, 1/2"
	G10102	1	Hex Nut, 1/2"-13
2.	GA5103	2	Idler Sprocket W/Bearing, 15 Tooth
3.	GA4470	1	Idler Mount
4.	GD5827	1	Cover
5.	GD5829	1	Arm
6.	G10053	1	Hex Head Cap Screw, 1/2"-13 x 2 1/2"
	G10228	1	Lock Washer, 1/2"
	G10102	1	Hex Nut, 1/2"-13
7.	G10602	7	Spring Pin, 1/4" x 1 1/2"
8.	GD5824	1	Plate
9.	GD5857	2	Spring
10.	GD5830	1	Angle Support
11.	G10478	2	Clevis Pin, 5/16" x 1"
	G10409	2	Retaining Ring, 5/16"
12.	G2100-03	1	Bearing, 7/8" Hex Bore, Spherical
13.	G3400-01	2	Flangette
14.	G10001	1	Hex Head Cap Screw, 3/8"-16 x 1"
	G10210	2	Washer, 3/8" USS
	G10203	1	Washer, 3/8" SAE
	GD5756	1	Special Nut, 3/8"-16
15.	G10037	4	Hex Head Cap Screw, 1/2"-13 x 1 1/4"
	G10228	4	Lock Washer, 1/2"
	G10102	4	Hex Nut, 1/2"-13

TRANSMISSION ASSEMBLY

ITEM	PART NO.	QTY.	DESCRIPTION
16.	GA5146	1	Sprocket Storage Rod
17.	GA5106	-	Sprocket, 17 Tooth
	GA5107	-	Sprocket, 19 Tooth
	GA5108	-	Sprocket, 23 Tooth (Qty. 2)
	GA5109	-	Sprocket, 24 Tooth
	GA5110	-	Sprocket, 25 Tooth
	GA5111	-	Sprocket, 26 Tooth
	GA5112	-	Sprocket, 27 Tooth
	GA5113	-	Sprocket, 28 Tooth
18.	GD2558	4	Lynch Pin, 1/4"
19.	GD5835	1	Shaft, 7/8" x 7"
20.	G3310-80	1	Chain, No. 40, 80 Pitch Including Connector Link
	GR0912	-	Connector Link, No. 40
21.	GD7822	1	Shaft, 7/8" x 7"
22.	GA5629	1	Transmission Plate W/ Bearings, Grease Fitting And Retaining Rings
	GA5116	-	Bearing, 7/8" Hex Bore, Cylindrical
	GA5624	-	Special Bearing, 7/8" Hex Bore x 1.6"
	GD6551	-	Ring
	G10641	-	Grease Fitting, 1/8" NPT
23.	G10233	4	Machine Bushing
24.	G10460	1	Cotter Pin, 1/4" x 2"
25.	GA4235	1	Ratchet Wrench W/Protective Closure
	G10445	-	Protective Closure
26.	GD7127	1	Shear Coupler
27.	G10670	1	Hair Pin Clip, No. 3
28.	GA5628	1	Idler W/Sprockets And Rings
	GD7426	-	Sprocket
	G10435	-	Ring
29.	GA5106	1	Sprocket, 17 Tooth
	GA5202	-	Sprocket, 34 Tooth (2 To 1 Drive Reduction)
30.	G3310-89	1	Chain, No. 40, 89 Pitch Including Connector And Offset Link
	G3310-08	-	Chain, No. 40, Used With 2 To 1 Drive Reduction
	GR0911	-	Offset Link, No. 40
	GR0912	-	Connector Link, No. 40
31.	GA5105	1	Sprocket, 15 Tooth
32.	GD6793	2	Stud, 5/8"-11 x 9 1/2" (Threaded Both Ends)
	G10230	4	Lock Washer, 5/8"
	G10107	4	Hex Nut, 5/8"-11
33.	GD4887-03	1	Sleeve, 3/4"
34.	G10016	1	Hex Head Cap Screw, 1/2"-13 x 2"
	G10216	2	Washer, 1/2" USS (Large)
	G10128	1	Machine Bushing, 1/2" (Small)
	G10228	1	Lock Washer, 1/2"
	G10102	1	Hex Nut, 1/2"-13
35.	G10312	3	Carriage Bolt, 5/16"-18 x 3/4"
	G10232	3	Lock Washer, 5/16"
	G10106	3	Hex Nut, 5/16"-18
36.	GD6819	1	Idler Sleeve, 7/16"
37.	GD2734-01	1	Sleeve, 1/2"
38.	G10462	1	Cotter Pin, 3/16" x 2"
39.	GD9047	1	Spacer
40.	GD0917	1	Lock Collar, Less Set Screws
	G10145	1	Set Screw, 5/16"-18 x 1/2"

MARKER ASSEMBLY, 6 ROW 30

MKR025/PFA054

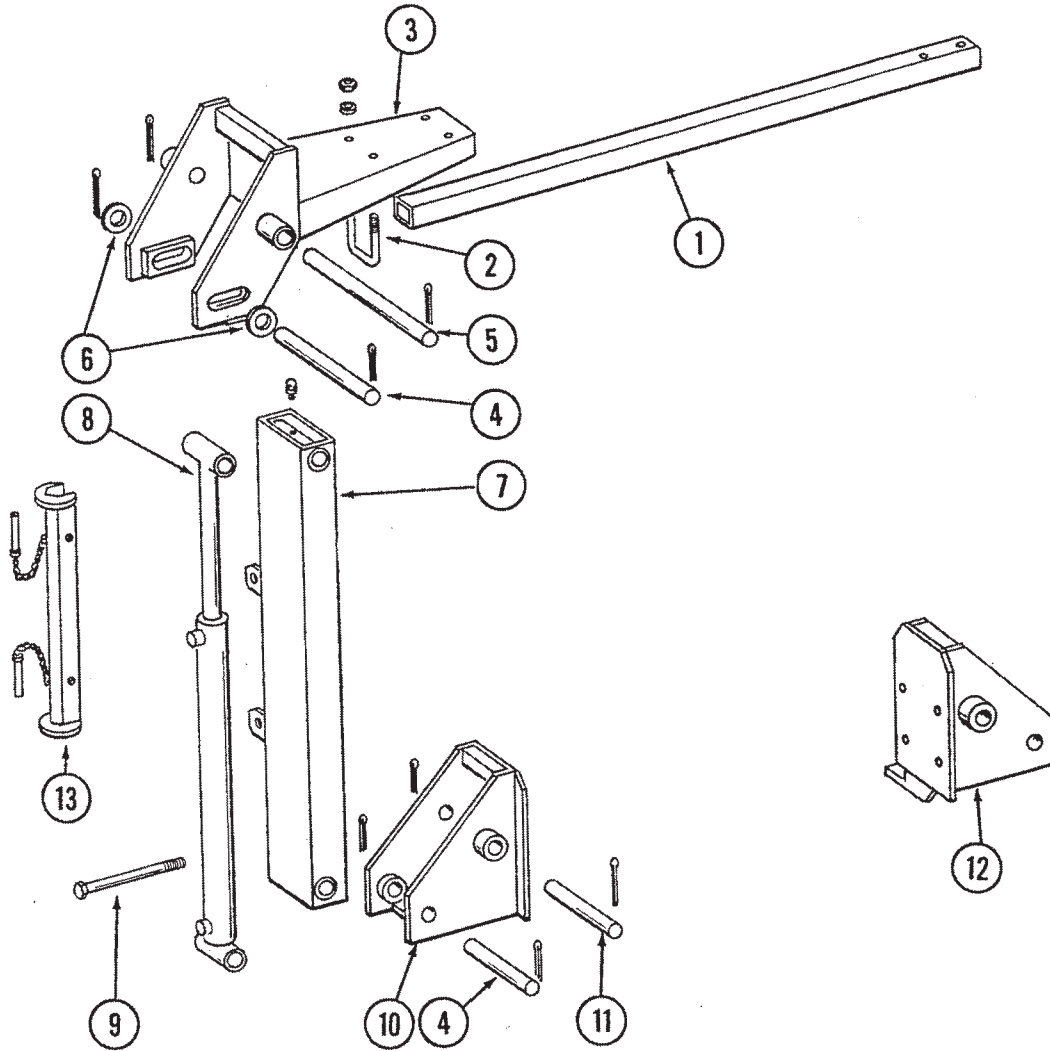

MARKER ASSEMBLY, 6 ROW 30

ITEM	PART NO.	QTY.	DESCRIPTION
		(Per Marker)	
1.	GD0453-02	1	Extension Tube, 40"
	GD0453-06	-	Extension Tube, 30" (Used With Interplant Option)
2.	GD2721	2	U-Bolt, 2" x 2" x 1/2"-13
	G10228	4	Lock Washer, 1/2"
	G10102	4	Hex Nut, 1/2"-13
3.	GA6442	1	Second Stage Arm, 20"
4.	GD2161	2	Pin, 1 1/4" x 8 1/4"
	G10460	4	Cotter Pin, 1/4" x 2"
5.	GD3214	1	Pin, 1 1/4" x 12" 1/4"
	G10460	2	Cotter Pin, 1/4" x 2"
6.	G10226	2	Washer, 1 1/4" SAE
7.	GA6585	1	First Stage Arm W/Grease Fittings, L.H. (Shown)
	GA6586	-	First Stage Arm W/Grease Fittings, R.H.
	G10641	-	Grease Fitting, 1/8"
8.		-	See "Marker Cylinder"
9.	G10008	4	Hex Head Cap Screw, 5/8"-11 x 2", Grade 2
	G10230	4	Lock Washer, 5/8"
10.	GA5130	1	Mount, L.H.
11.	GD0652	1	Pin, 1 1/4" x 9 1/2"
	G10460	2	Cotter Pin, 1/4" x 2"
12.	GA6409	-	Mount, R.H.
13.	GA5526	1	Lockup

MARKER ASSEMBLY, 8 ROW 30

MKR026/PFA054/MKR019

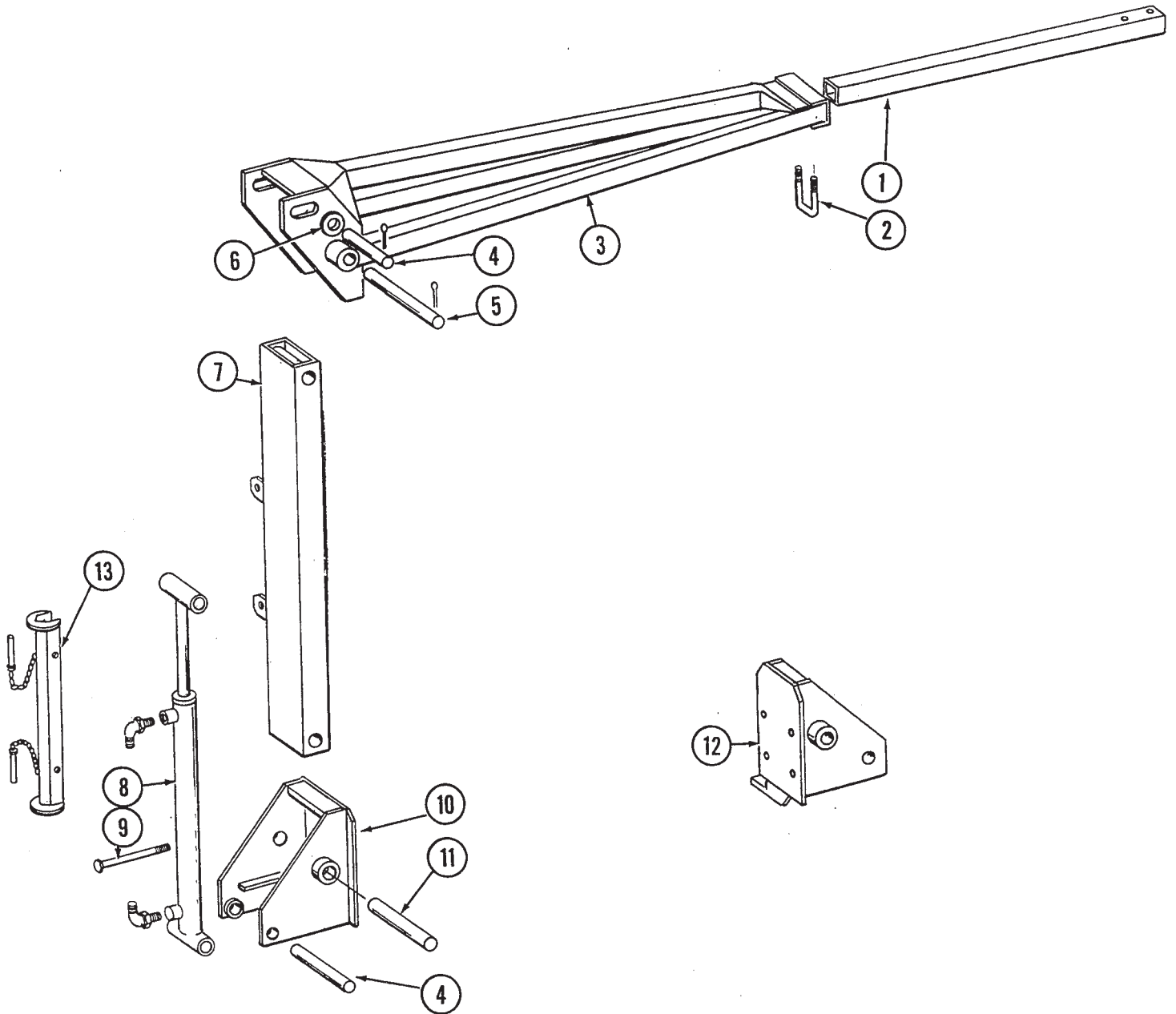

MARKER ASSEMBLY, 8 ROW 30

ITEM	PART NO.	QTY.	DESCRIPTION
		(Per Marker)	
1.	GD0453-03	1	Extension Tube, 50"
2.	GD2721	1	U-Bolt, 2" x 2" x 1/2"-13
	G10228	2	Lock Washer, 1/2"
	G10102	2	Hex Nut, 1/2"-13
3.	GA5188	1	Second Stage Arm, 46"
4.	GD2161	2	Pin, 1 1/4" x 8 1/4"
	G10460	4	Cotter Pin, 1/4" x 2"
5.	GD3214	1	Pin, 1 1/4" x 12" 1/4"
	G10460	2	Cotter Pin, 1/4" x 2"
6.	G10226	2	Washer, 1 1/4" SAE
7.	GA6585	1	First Stage Arm W/Grease Fittings, L.H. (Shown)
	GA6586	-	First Stage Arm W/Grease Fittings, R.H.
	G10641	-	Grease Fitting, 1/8"
8.		-	See "Marker Cylinder"
9.	G10008	4	Hex Head Cap Screw, 5/8"-11 x 2", Grade 2
	G10230	4	Lock Washer, 5/8"
10.	GA5130	1	Mount, L.H.
11.	GD0652	1	Pin, 1 1/4" x 9 1/2"
	G10460	2	Cotter Pin, 1/4" x 2"
12.	GA6409	-	Mount, R.H.
13.	GA5526	1	Lockup

MARKER SPINDLE/HUB/BLADE

MKR020

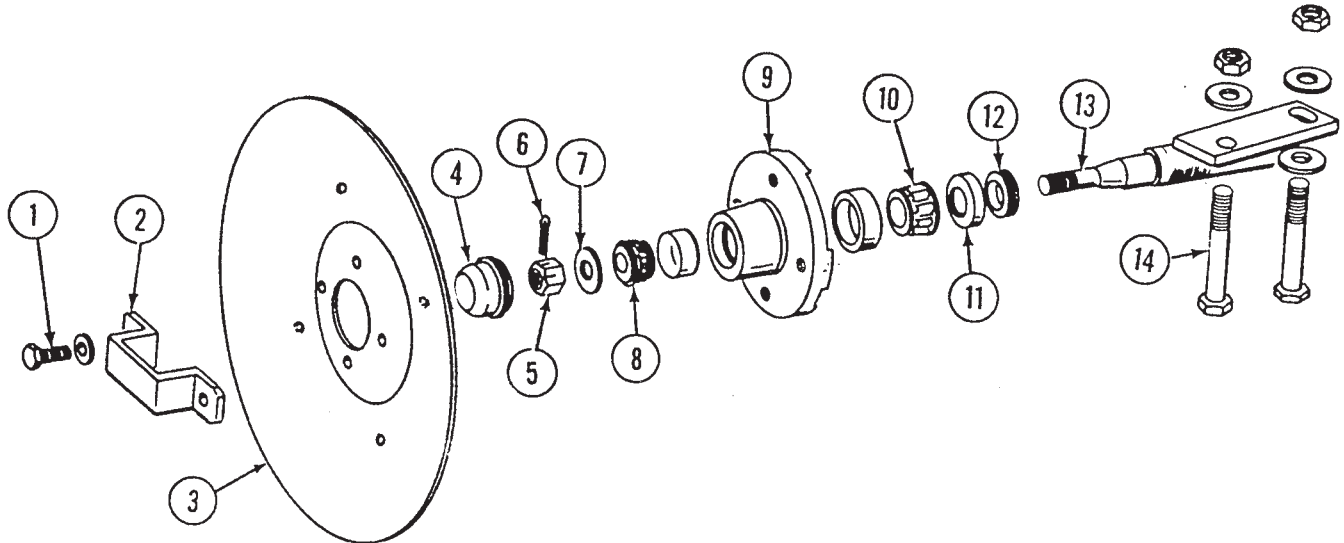

ITEM	PART NO.	QTY.	DESCRIPTION
		(Per Marker)	
1.	G10722	2	Hex Head Cap Screw, 1/2"-20 x 1"
	G10228	2	Lock Washer, 1/2"
2.	GD2597	1	Retainer
3.	GD0746	1	Blade, 16"
4.	GD0840	1	Cap
5.	G10725	1	Hex Slotted Nut, 5/8"-18
6.	G10544	1	Cotter Pin, 5/32" x 1"
7.	G10724	1	Washer, 5/8"
8.	GA0257	1	Outer Bearing
9.	GA0167	1	Hub With Cups
	GR0151	-	Outer Cup
	GR0150	-	Inner Cup
10.	GA0245	1	Inner Bearing
11.	GA0243	1	Grease Seal
12.	GA0899	1	Rubber Seal
13.	GA1677	1	Spindle, L.H. (Shown)
	GA1676	-	Spindle, R.H.
14.	G10033	2	Hex Head Cap Screw, 1/2"-13 x 3 1/2"
	G10168	2	Machine Bushing, 1/2", 7 Gauge
	G101022	2	Hex Nut, 1/2"-13
A.	GA1679	-	Hub And Spindle Assembly, L.H. (Items 1 And 4-13)
	GA1678	-	Hub And Spindle Assembly, R.H. (Items 1 And 4-13)

ROTATION CYLINDER

CYL032

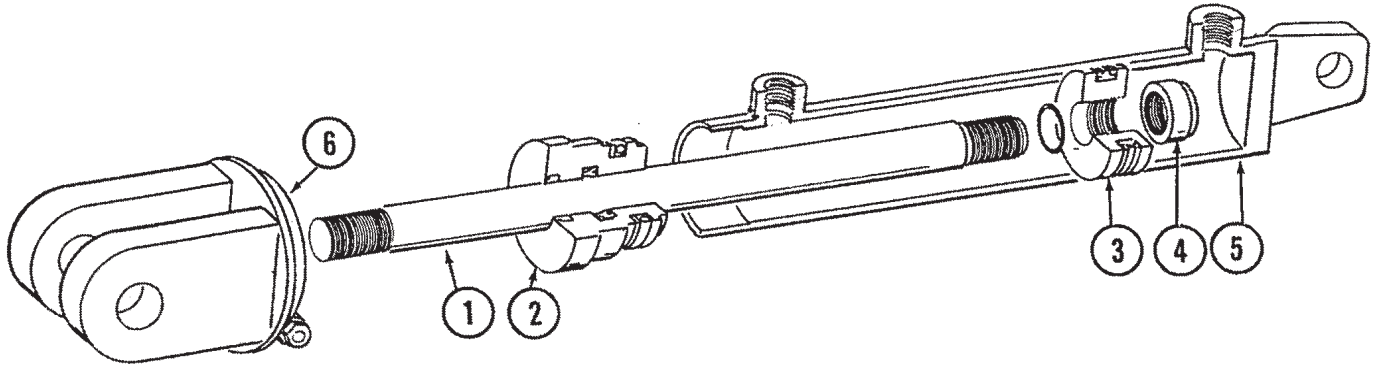

ITEM PART NO. QTY. DESCRIPTION
(Per Cylinder)

1.	GD9241	1	Rod
2.	GD5951	1	Gland
3.	GD9239	1	Piston
4.	GR0983	1	Lock Nut, 1 1/4"-12
5.	GA6524	1	Barrel
6.	GA6525	1	Clevis W/3/8"-16 x 1 3/4" Socket Head Cap Screw And Lock Nut
A.	GA6349	-	Cylinder Complete, 3" x 16"
B.	GR1185	-	Seal Kit, Includes: (1)Wear Ring, (1)Uniring, (2)O-Rings, (1)BU Ring, (1)U-Cup, (1)Wiper

LIFT CYLINDER

CYL054/RH

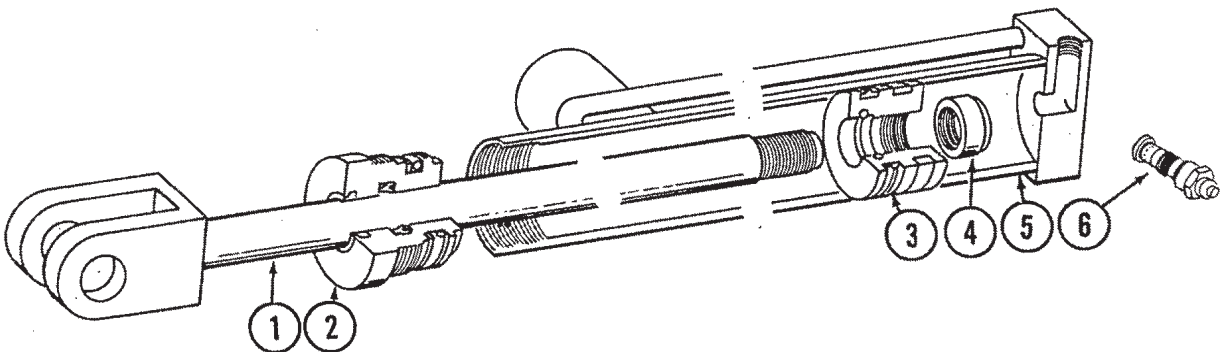

ITEM PART NO. QTY. DESCRIPTION
(Per Cylinder)

1.	GA6523	1	Rod
2.	GD6574	1	Gland
3.	GD9238	1	Piston
4.	GR0983	1	Lock Nut, 1 1/4"-12
5.	GA6522	1	Barrel
6.	GR1183	1	Counter Balance Valve
A.	GA6350	-	Cylinder Complete, 3" x 48"
B.	GR1184	-	Seal Kit, Includes: (1)Wear Ring, (1)Uniring, (2)O-Rings, (1)BU Ring, (1)U-Cup, (1)U-Cup, (1)Wiper

KICKOUT CYLINDER

CYL035/CYL050

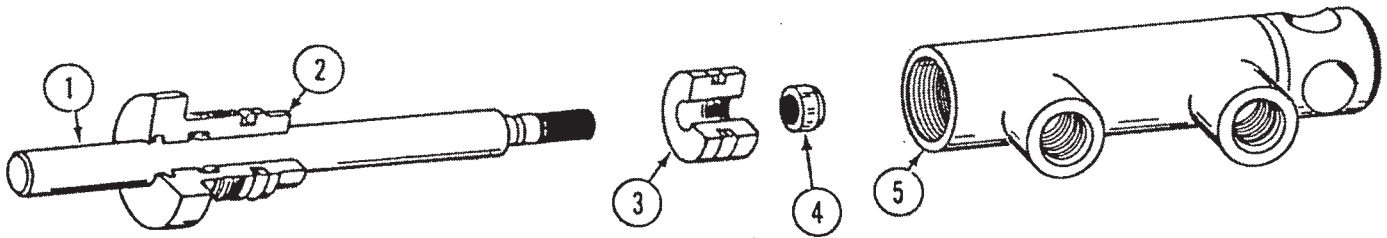

ITEM	PART NO.	QTY.	DESCRIPTION
(Per Cylinder)			
1.	GD7124	1	Rod
2.	GD7122	1	Gland
3.	GD7120	1	Piston
4.	GR0999	1	Lock Nut, 1/2"-20
5.	GA6020	1	Barrel
A.	GA4309	-	Cylinder Complete, 1 1/2" x 2 1/2"
B.	GR1001	-	Seal Kit, Includes: (2)O-Rings, (1)U-Cup, (1)Rod Wiper, (1)Seal

MARKER CYLINDER

CYL039

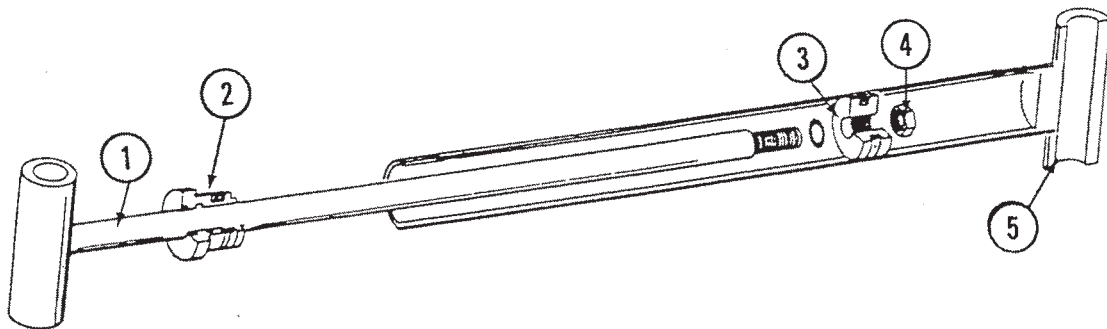

ITEM	PART NO.	QTY.	DESCRIPTION
(Per Cylinder)			
1.	GA5459	1	Rod
2.	GD5949	1	Gland
3.	GD4632	1	Piston
4.	GR0959	1	Lock Nut, 3/4"-16
5.	GA5460	1	Barrel
A.	GA5097	-	Cylinder Complete, 2" x 20"
B.	GR0927	-	Seal Kit, Includes: (1)T Seal, (2)O-Rings, (1)BU Ring, (1)U-Cup, (1)Wiper

MARKER SEQUENCING/FLOW CONTROL VALVE

ITEM	PART NO.	QTY.	DESCRIPTION
1.	G6400-06	4	Connector, 9/16"-18 Male 37° JIC to 9/16"-18 O-Ring *
	GR1045	-	O-Ring
2.	GR1034	2	Hex Socket O-Ring Plug
	GR1035	-	O-Ring
3.	GR1032	2	Port Adapter
	GR1045	-	O-Ring
4.	GR1033	1	Detent Spring
5.	GR1036	2	Spring
6.	GR1044	3	7/16" Check Ball
7.	GR1043	2	1/4" Steel Ball
8.		1	Valve Body (Non-stock Item)
9.	GR1047	2	Hex Socket Plug
	GR1037	-	O-Ring
10.		-	Spool (Non-stock Item)
11.	GR1042	2	Adjustment Screw
12.	GR1048	2	Hex Jam Nut, 1/2"-20
13.	GR1038	2	Needle
14.	GR1039	2	Spring Pin
15.	GR1046	2	Compression Spring
16.	GR1040	2	O-Ring
17.	GR1041	2	Teflon BU Ring
18.		-	See "Hydraulic System"
A.	GA5552	-	Valve Assembly Complete (Items 1-17)
B.	GA5572	-	Flow Control Portion Only (Items 11-17)

VVB025

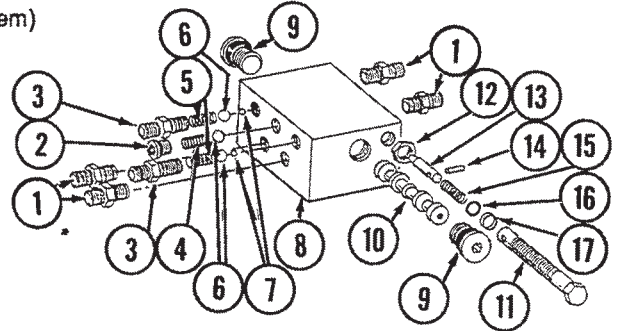
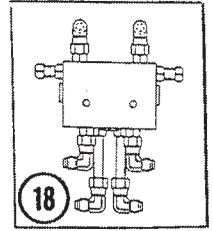

*Not used.

SELECTOR VALVE

ITEM	PART NO.	QTY.	DESCRIPTION
1.	GR1096	1	Seal Kit
2.		1	Block (Non-stock Item)
3.	GR1177	1	Spool W/Handle
4.	GR1178	1	Restrictor
A.	GA6438	-	Valve Assembly Complete

VVB028

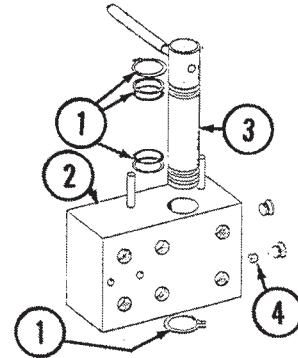

STROKE LIMITER VALVE

ITEM	PART NO.	QTY.	DESCRIPTION
1.		1	Block (Non-stock Item)
2.	GR1281	1	Adapter Plug
3.	GR1282	1	Piston Rod And Poppet Assembly
A.	GA6884	-	Stroke Limiter Valve Complete
B.	GR1289	-	Seal Kit Includes: (2)O-Rings, (1)BU Ring, (1)Rod Seal

VVB027rev

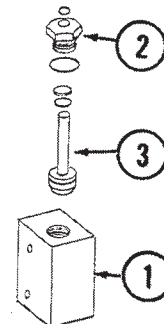

HYDRAULIC SYSTEM

L0133-35

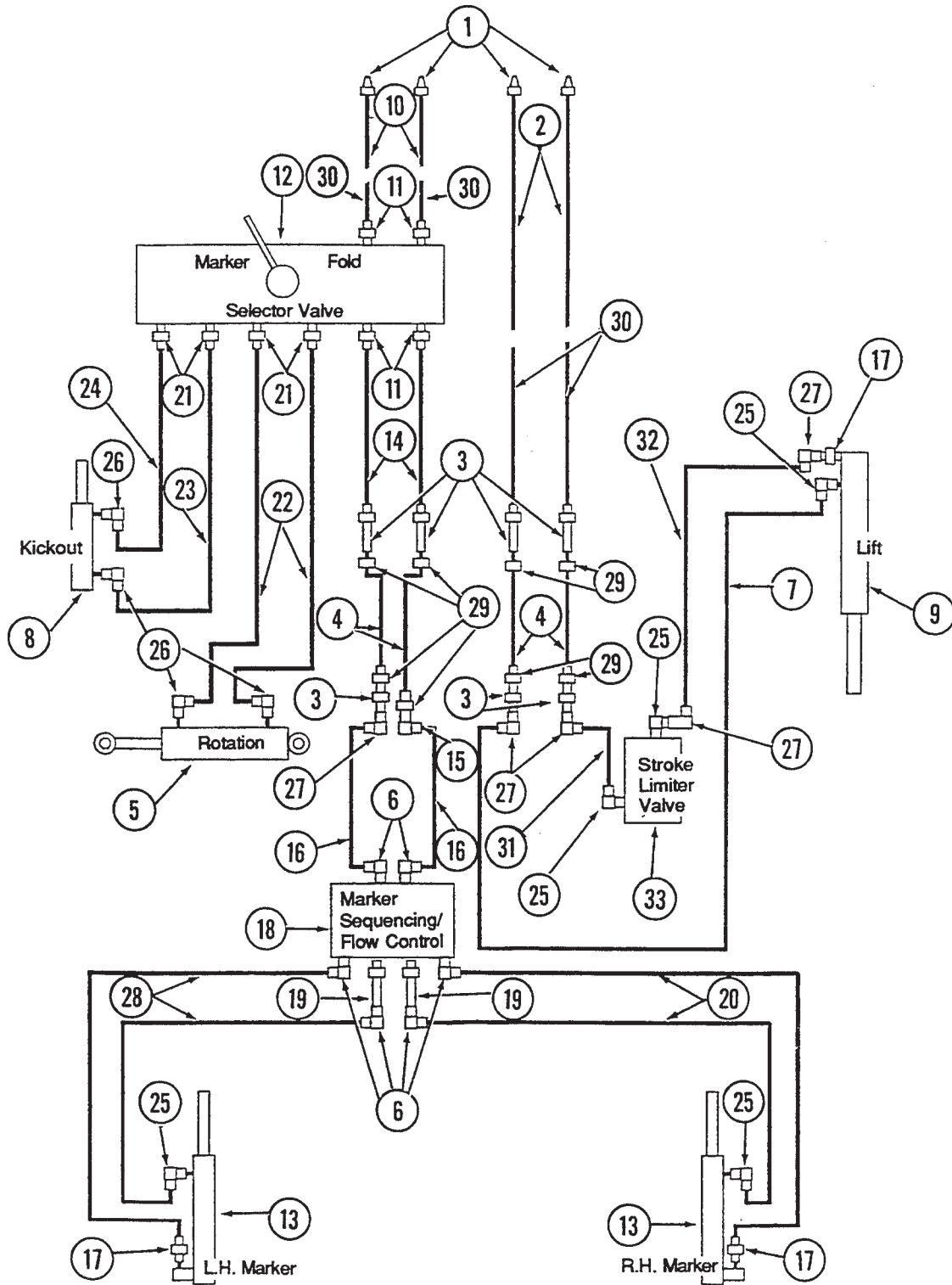

HYDRAULIC SYSTEM

ITEM	PART NO.	QTY.	DESCRIPTION
1.	GD4086	4	Pioneer (ISO) Tip
2.	GA3151	2	Hose Assembly, 3/8" x 234"
3.	G2700-08	7	Bulkhead, 3/4"-16 Male JIC
4.	GA1021	4	Hose Assembly, 3/8" x 56"
5.		-	See "Rotation Cylinder"
6.	G6500-08-06	6	Elbow, 3/4"-16 JIC Male To 9/16"-18 JIC Female
7.	GA1055	2	Hose Assembly, 3/8" x 66"
8.		-	See "Kickout Cylinder"
9.		-	See "Lift Cylinder"
10.	GA1023	2	Hose Assembly, 3/8" x 76"
11.	G6400-08-06	4	Connector, 3/4"-16 Male JIC To 9/16"-18 O-Ring
12.		-	See "Selector Valve"
13.		-	See "Marker Cylinder"
14.	GA1026	2	Hose Assembly, 3/8" x 152"
15.	G2701-08	1	Tube Elbow, 3/4"-16 Male JIC
16.	GA1084	2	Hose Assembly, 3/8" x 23 1/4"
17.	G6400-08	3	Connector, 3/4"-16 JIC To 3/4"-16 O-Ring
18.		-	See "Marker Sequencing/Flow Control Valve"
19.	G6400-L-06	2	Long Connector, 9/16"-18 JIC To O-Ring
20.	GA1041	2	Hose Assembly, 3/8" x 130", 6 Row 30
	GA1090	-	Hose Assembly, 3/8" x 162", 8 Row 30
21.	G6400-06	4	Connector, 9/16"-18 Male JIC to 9/16"-18 O-Ring
22.	GA1107	2	Hose Assembly, 1/4" x 140"
23.	GA1153	1	Hose Assembly, 1/4" x 56", 6 Row 30
	GA1194	-	Hose Assembly, 1/4" x 30", 8 Row 30
24.	GA1141	1	Hose Assembly, 1/4" x 62", 6 Row 30
	GA1195	-	Hose Assembly, 1/4" x 34", 8 Row 30
25.	G6801-08	4	Elbow, 3/4"-16 JIC Male To 3/4"-16 O-Ring
26.	G6801-06-08	4	Elbow, 9/16"-18 Male JIC To 3/4"-16 O-Ring
27.	G6500-08	3	Elbow, 3/4"-16 JIC Male To Female
28.	GA3137	2	Hose Assembly, 3/8" x 140", 6 Row 30
	GA3105	-	Hose Assembly, 3/8" x 170", 8 Row 30
29.	G306-08	8	Lock Nut, 3/4"-16
30.	GA1048	4	Hose Assembly, 3/8" x 12", 8 Row 30 Only
31.	GA1018	1	Hose Assembly, 3/8" x 40"
32.	GA1076	1	Hose Assembly, 3/8" x 30"
33.		-	See "Stroke Limiter Valve"

ELECTRONIC SEED MONITOR

D-0640-0001/D-0640-0003/D-0640-0004/D-1172-0001/D-1172-0002/ECP019/ECP020/ECP021/ECP022

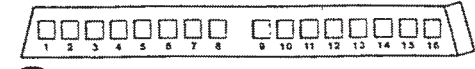
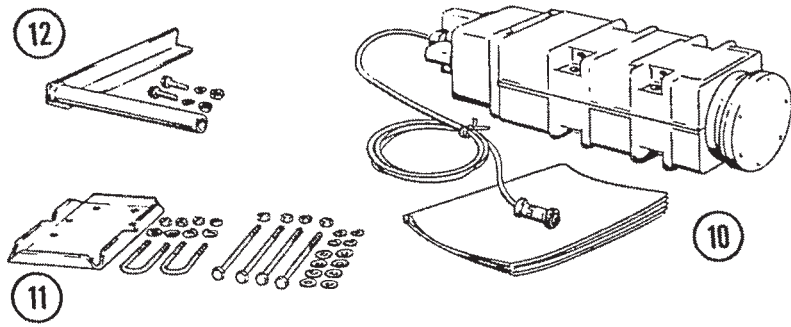

13

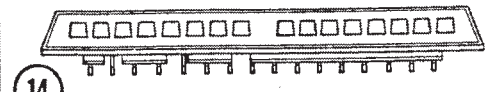

14

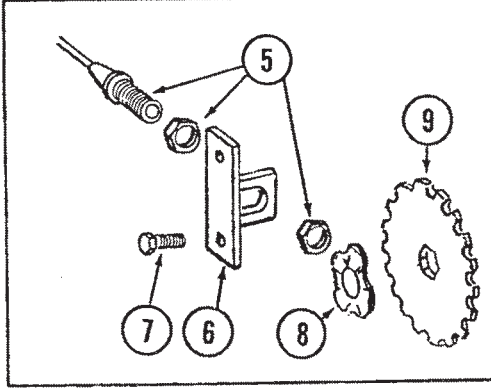
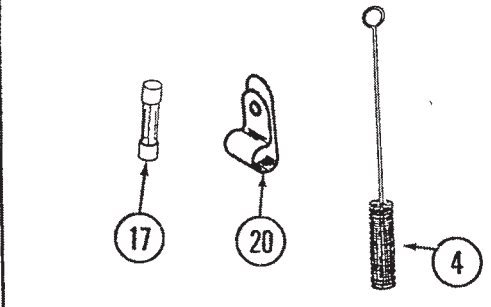
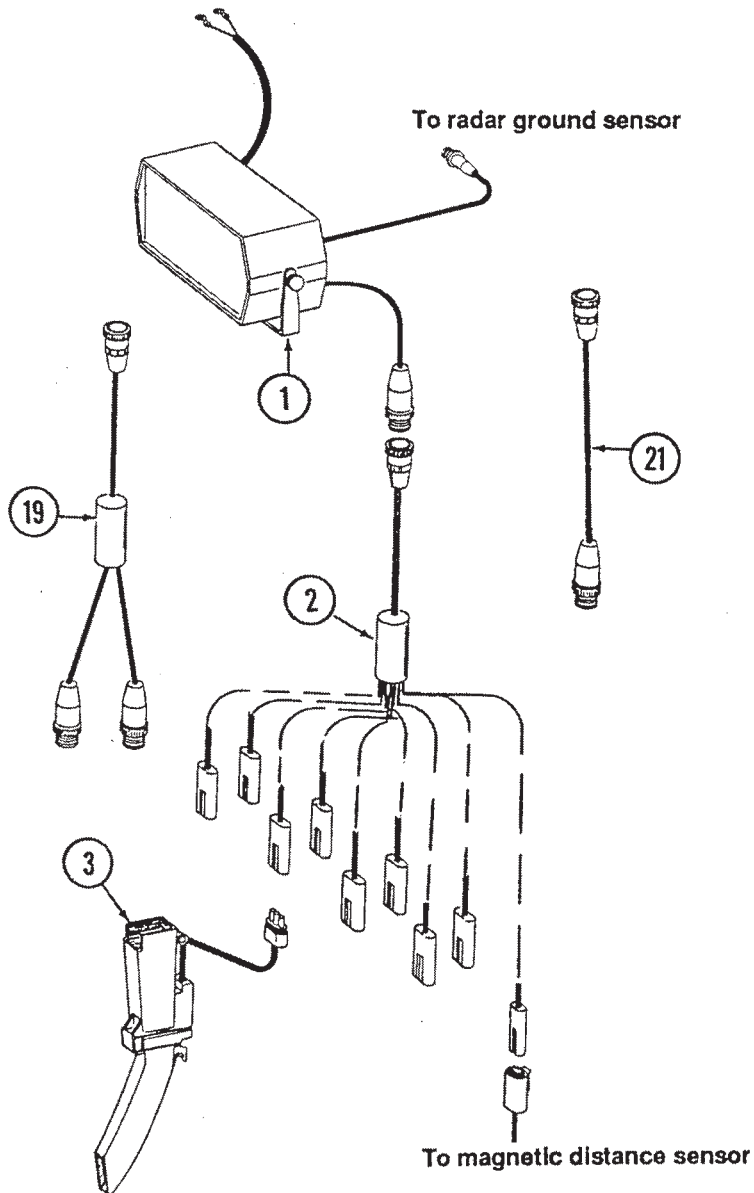

ELECTRONIC SEED MONITOR

ITEM	PART NO.	DESCRIPTION
1.	GA5873	Console W/Mounting Bracket, KM1000
	GA5874	Console W/Mounting Bracket, KM3000
	GR1077	Mounting Bracket, KM1000
	GR1078	Mounting Bracket, KM3000
	GR1079	Console Mounting Bracket Hardware Package(Includes 2 wellnuts, 2 knobs and 1/4" hardware)
2.	GA5876	Planter Harness, 6 Row
	GA5877	Planter Harness, 8 Row
3.	GA5880	Seed Tube W/High Rate Sensor
	GR1062	Seed Tube (With holes for high rate sensor installation)
	GR1087	Sensor Only (For A5880)
	GR0676	Sunshade
	GD2117	Tie Strap, 14 1/2"
4.	GR0594	Brush
5.	GA5600	Magnetic Distance Sensor (Use W/KM3000 Console Only)
6.	GD8770	Bracket
7.	G10004	Hex Head Cap Screw, 3/8"-16 x 1 1/4"
	G10229	Lock Washer, 3/8"
	G10101	Hex Nut, 3/8"-16
8.	GD8771	Spring Wave Washer
9.	GD8751	Magnetic Distance Sensor Pulse Wheel (Use W/KM3000 Console Only)
10.	GA4223	Radar Ground Sensor (Use W/KM3000 Console Only)
11.	GA4229	Radar Sensor Mounting Bracket Package
12.	GA4230	Radar Sensor Pipe Mounting Package
13.	GR1081	KM1000 Bezel Decal, 6 Row
	GR1083	KM1000 Bezel Decal, 16 Row (Used On 8 Row And 6 Row With Interplant)
14.	GR1080	KM1000 Bezel
15.	GR0595	Bulb, KM1000 Row Lamp (Not Shown)
16.	GR1084	Bulb, KM3000 Backlite (Not Shown)
17.	GR0866	Fuse, 5-amp, Type AGC
	GR1085	Fuse, 2-amp, Type AGC
18.	GR0582	Male Hitch Connector Kit (Not Shown)
	GR0583	Female Hitch Connector Kit (Not Shown)
19.	GA5884	Y-Connector, 16 Row
20.	GD6291	Insulated Clamp
21.	GA5881	Extension Cable, 15", 1-32 Rows

INTERPLANT DRIVE

PTD73

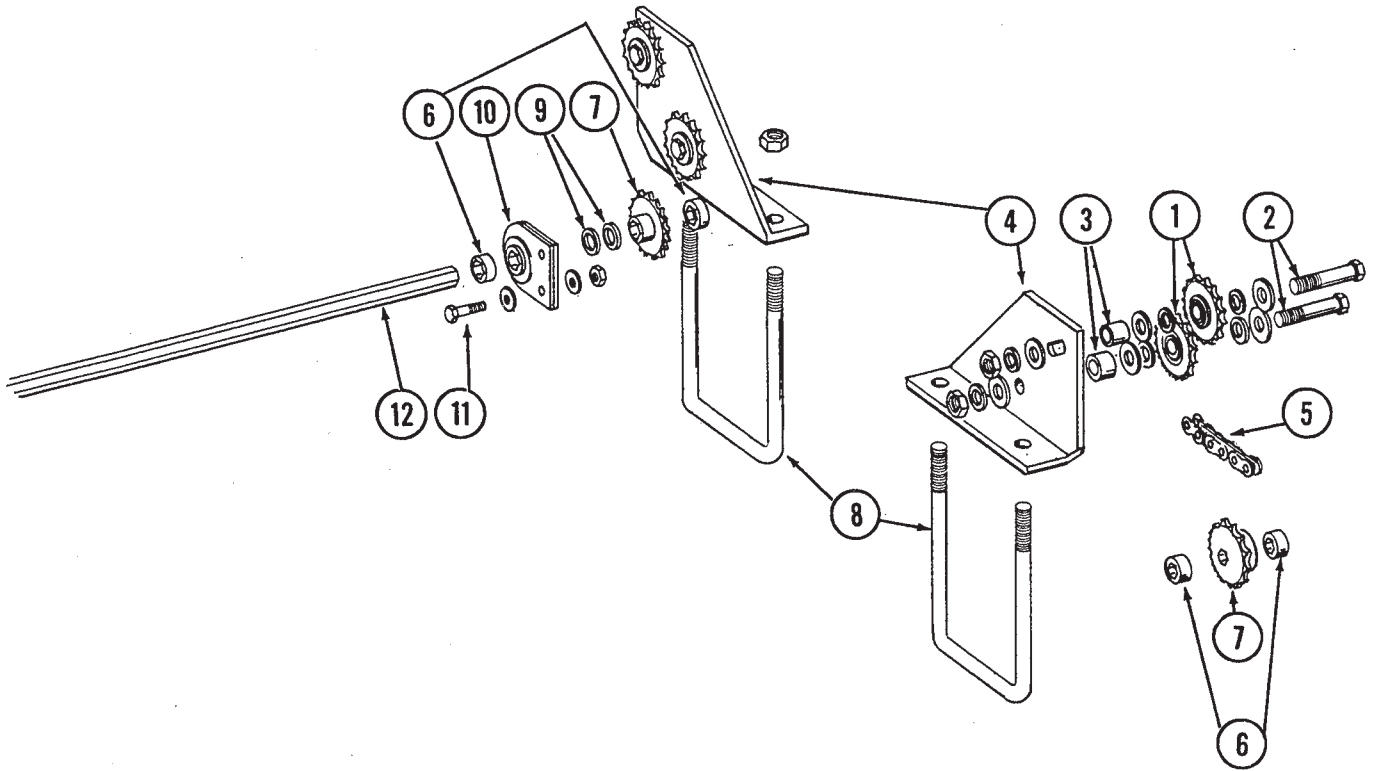

INTERPLANT DRIVE

ITEM	PART NO.	QTY.	DESCRIPTION
1.	GA5103	4	Idler Sprocket W/Bearing, 15 Tooth
2.	G10581	4	Hex Head Cap Screw, 1/2"-13 x 2 1/4"
	G10216	20	Washer, 1/2" USS
	G10228	4	Lock Washer, 1/2"
	G10102	4	Hex Nut, 1/2"-13
3.	GD9229	4	Spacer
4.	GD9106	2	Mount
5.	G3310-204	1	Chain, No. 40, 204 Pitch Including Connector Link
	GR0912	-	Connector Link, No. 40
6.	GD0917	4	Lock Collar, Less Set Screws
	G10145	4	Set Screw, 5/16"-18 x 1/2"
7.	GA5107	2	Sprocket, 19 Tooth
8.	GD8306	2	U-Bolt, 7" x 5" x 1/2"-13
	G10228	4	Lock Washer, 1/2"
	G10102	4	Hex Nut, 1/2"-13
9.	G10233	-	Machine Bushing (As Required)
10.	GA2180	-	Bearing Hanger, 7/8" Hex Bore
11.	G10001	-	Hex Head Cap Screw, 3/8"-16 x 1"
	G10229	-	Lock Washer
	G10101	-	Hex Nut, 3/8"-16
12.	GD0914-155	-	Drill Shaft, 6 Row 30
	GD0914-215	-	Drill Shaft, 8 Row 30

DOUBLE DISC FERTILIZER OPENER AND MOUNTING BAR

FOC007/FOC008

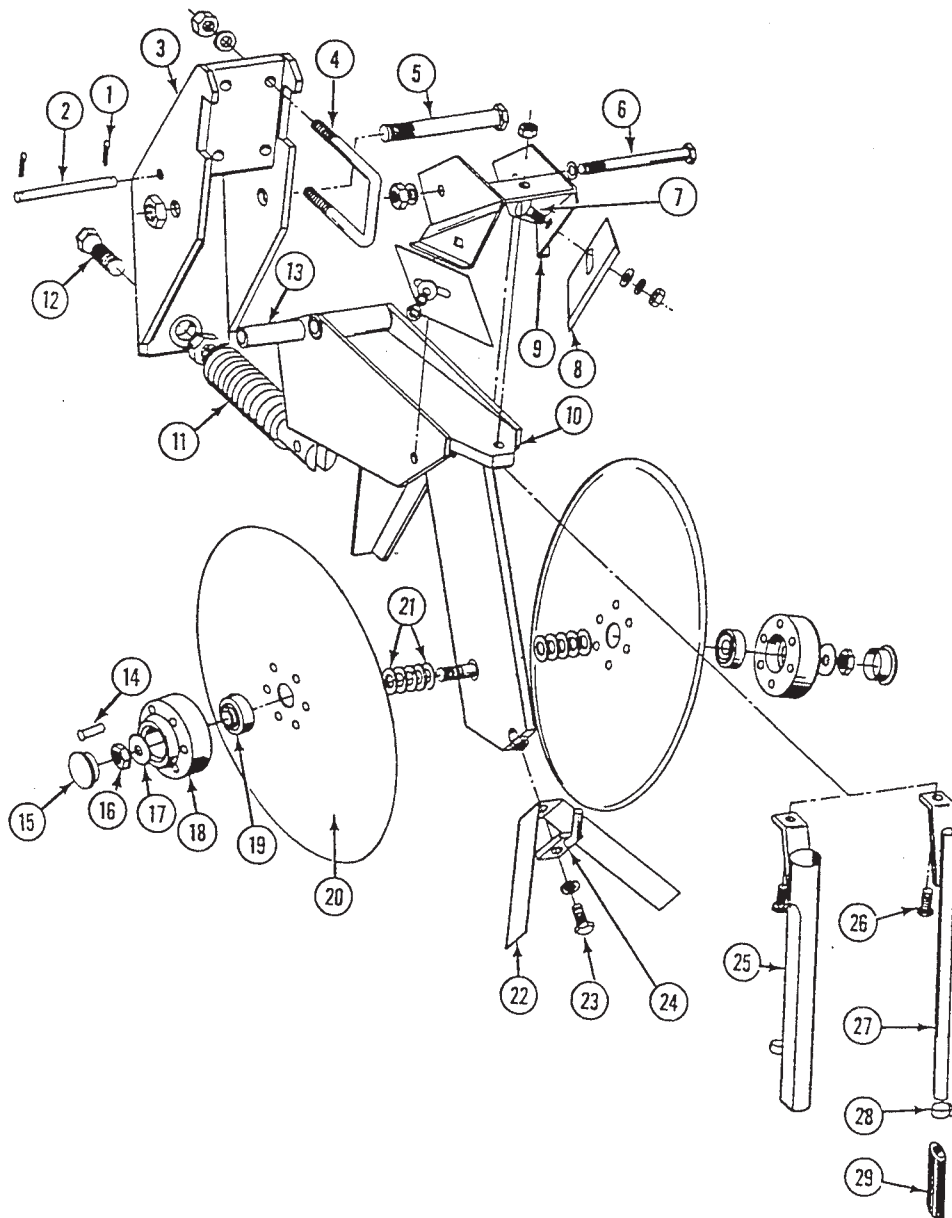
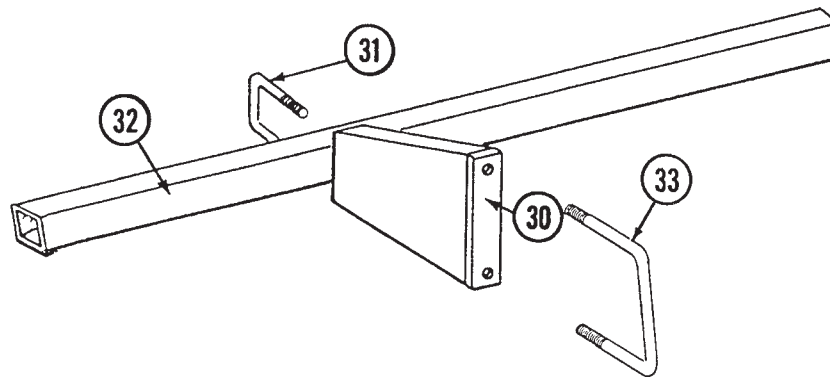

DOUBLE DISC FERTILIZER OPENER AND MOUNTING BAR

ITEM	PART NO.	QTY.	DESCRIPTION
		(Per Opener)	
1.	G10451	2	Cotter Pin, 1/8" x 1"
2.	GD1657	1	Lockup Pin
3.	GA0785	1	Bracket
4.	GD1138	2	U-Bolt, 2 1/2" x 2 1/2" x 1/2"-13
	G10228	4	Lock Washer, 1/2"
	G10102	4	Hex Nut, 1/2"-13
5.	G10046	1	Hex Head Cap Screw, 5/8"-11 x 5"
	G10107	1	Lock Nut, 5/8"-11
6.	G10045	1	Hex Head Cap Screw, 1/2"-13 x 4 1/2"
	G10111	1	Lock Nut, 1/2"-13
7.	G10305	2	Carriage Bolt, 3/8"-16 x 1"
	G10210	2	Washer, 3/8" USS
	G10229	2	Lock Washer, 3/8"
	G10101	2	Hex Nut, 3/8"-16
8.	GD1673	1	Scraper
9.	GA0810	1	Scraper Mount
10.	GA0308	1	Shank
11.	GA0328	1	Spring
12.	GD0962	1	Hex Head Adjusting Bolt, 5/8"-18
	G10499	1	Jam Nut, 5/8"-18
13.	GD0487	1	Bushing
14.	G10542	12	Rivet, 1/4" x 1 5/16"
15.	GD1132	2	Cap
16.	G10503	1	Jam Nut, R.H., 5/8"-11
	G10504	1	Jam Nut, L.H., 5/8"-11
17.	G10204	2	Machine Bushing, 21/32"
18.	GB0134	2	Hub
19.	GA2014	2	Bearing
20.	GD1030	2	Blade
21.	G10213	-	Machine Bushing, 11/16" (As Required)
22.	GD2589	1	Inner Scraper
23.	G10019	1	Hex Head Cap Screw, 5/16"-18 x 1"
	G10232	1	Lock Washer, 5/16"
24.	GA0312	1	Mount
25.	GA1369	1	Drop Tube, Dry Fertilizer
26.	G10133	1	Hex Head Cap Screw, 5/16"-18 x 1 1/2"
	G10109	1	Lock Nut, 5/16"-18
27.	GA0318	1	Drop Tube, Liquid Fertilizer
28.	G10681	1	Clamp, No. 6
29.	GD1797	1	Extension
30.	GA5237	-	Support, L.H. (Shown)
	GA5236	-	Support, R.H.
31.	GD1138	-	U-Bolt, 2 1/2" x 2 1/2" x 1/2"-13
	G10228	-	Lock Washer, 1/2"
	G10102	-	Hex Nut, 1/2"-13
32.	GD0971-14	-	Bar, 72", 6 Row 30
	GD0971-04	-	Bar, 100 1/4", 8 Row 30
33.	GD1113	-	U-Bolt, 5" x 7" x 5/8"-11
	G10230	-	Lock Washer, 5/8"
	G10104	-	Hex Nut, 5/8"-11
A.	GA0320	-	Disc And Bearing Assembly (Items 18-20)

SINGLE DISC FERTILIZER OPENER

FOC016/FOC007

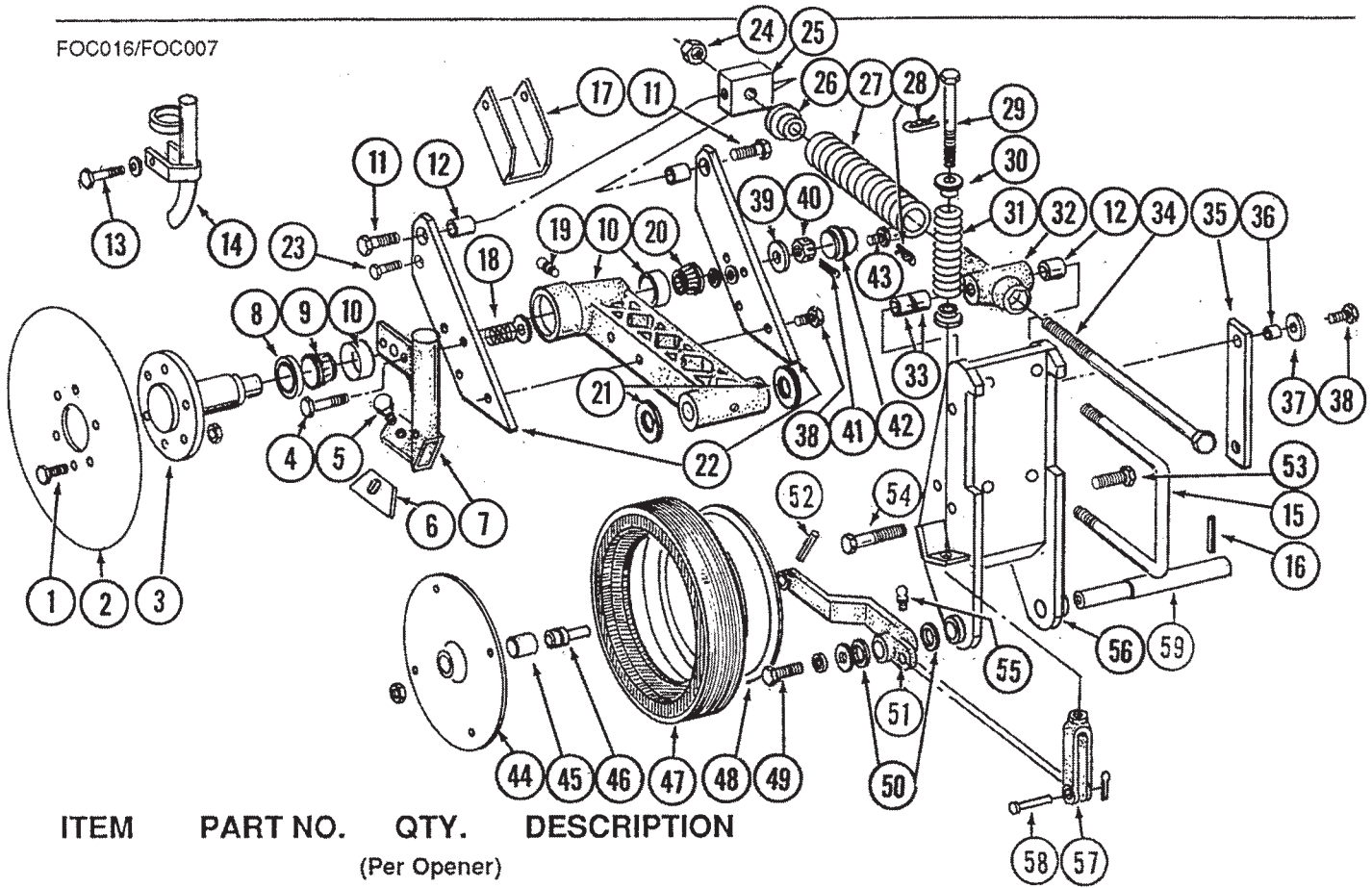

ITEM	PART NO.	QTY.	DESCRIPTION
------	----------	------	-------------

(Per Opener)

1.	G10594	6	Bolt, 1/2"-13 x 1 1/2"
	G10111	6	Lock Nut, 1/2"-13
2.	GD7900	1	Blade, 18"
	GD8247	-	Optional Blade, 20"
3.	GB0205	1	Spindle
4.	G10049	2	Hex Head Cap Screw, 3/8"-16 x 2 1/2"
	G10210	2	Washer, 3/8" USS
	G10108	2	Lock Nut, 3/8"-16
5.	G10599	1	Carriage Bolt, 3/8"-16 x 1 1/4"
	G10210	1	Washer, 3/8"
	G10229	1	Lock Washer, 3/8"
	G10101	1	Hex Nut, 3/8"-16
6.	GD7912	1	Scraper
7.	GB0210	-	Drop Tube, R.H.
	GB0209	-	Drop Tube, L.H. (Shown)
8.	GA4286	1	Seal
9.	GA4287	1	Outer Bearing
10.	GA5887	1	Arm W/Cups
	GD6553	-	Outer Cup
	GR0188	-	Inner Cup
11.	G10055	2	Hex Head Cap Screw, 5/8"-11 x 1 1/4"
	G10230	2	Lock Washer, 5/8"
	G10205	2	Washer, 5/8" SAE
12.	GB0218	1	Bushing
13.	G10403	1	Hex Head Cap Screw, 1/4"-20 x 2 1/2"
	G10209	2	Washer, 1/4" USS
	G10110	1	Lock Nut, 1/4"-20
14.	GA6408	1	Liquid Drop Tube
15.	GD1113	2	U-Bolt, 5" x 7" x 5/8"-11
	G10230	4	Lock Washer, 5/8"
	G10104	4	Hex Nut, 5/8"-11

SINGLE DISC FERTILIZER OPENER

ITEM	PART NO.	QTY.	DESCRIPTION
		(Per Opener)	
16.	G10610	1	Spring Pin, 3/8" x 2"
17.	GD8238	1	Channel
18.	GD7962	2	Spring
19.	G10641	2	Grease Fitting, 1/8" NPT
20.	GA0237	1	Inner Bearing
21.	G10322	-	Bushing (As Required)
22.	GD8224	2	Bar
23.	G10001	2	Hex Head Cap Screw, 3/8"-16 x 1"
	G10108	2	Lock Nut, 3/8"-16
24.	G10105	3	Hex Nut, 3/4"-10
25.	GD7908	1	Tap Block
26.	GB0213	1	Spring Guide
27.	GD2115	1	Compression Spring
28.	G10592	2	Hair Pin Clip, No. 11
29.	GD8214	1	Special Bolt
30.	GB0212	2	Washer
31.	GD8308	1	Spring
32.	GB0206	1	Guide Rod
33.	GD8815	2	Bushing, 1 1/8"
34.	GD7907	1	Special Bolt
35.	GD8239	1	Bar Hook
36.	GD7904-02	1	Tube
37.	G10206	3	Washer, 1/2" SAE
38.	G10039	5	Hex Head Cap Screw, 1/2"-13 x 1 3/4"
	G10111	5	Lock Nut, 1/2"-13
39.	G10220	1	Machine Bushing
40.	G10507	1	Slotted Nut, 1"-14
41.	G10459	1	Cotter Pin, 3/16" x 1 1/2"
42.	GD1104	1	Cap
43.	GD8276	1	Pin
	G10237	1	Lock Washer, 7/16"
	G10100	1	Hex Nut, 7/16"-14
44.	GD4888	1	Half Wheel
45.	GB0118	1	Sleeve
46.	GA2022	1	Bearing
47.	GD4850	1	Offset Tire
48.	GD1048	1	Half Wheel
49.	G10438	1	Hex Head Cap Screw, 1/2"-13 x 3/4"
	G10228	1	Lock Washer, 1/2"
	G10216	1	Washer, 1/2" USS
50.	G10526	10	Bushing
51.	GD8030	-	Wheel Arm, R.H.
	GD8031	-	Wheel Arm, L.H. (Shown)
52.	G10603	1	Spring Pin, 1/4" x 1 1/4"
53.	G10007	1	Hex Head Cap Screw, 5/8"-11 x 1 1/2"
	G10230	1	Lock Washer, 5/8" SAE
54.	G10010	1	Hex Head Cap Screw, 5/8"-11 x 3"
	G10205	1	Washer, 5/8" SAE
	G10230	1	Lock Washer, 5/8"
55.	G10640	1	Grease Fitting, 1/4"-28
56.	GA5728	-	Opener Mount, R.H.
	GA5727	-	Opener Mount, L.H. (Shown)
57.	GD8218	1	Yoke
58.	G10560	1	Clevis Pin, 1/2" x 1 3/4"
	G10456	1	Cotter Pin, 1/8" x 3/4"
59.	GD7911	1	Pivot Pin

DRY FERTILIZER TRANSMISSION ASSEMBLY

PTD072

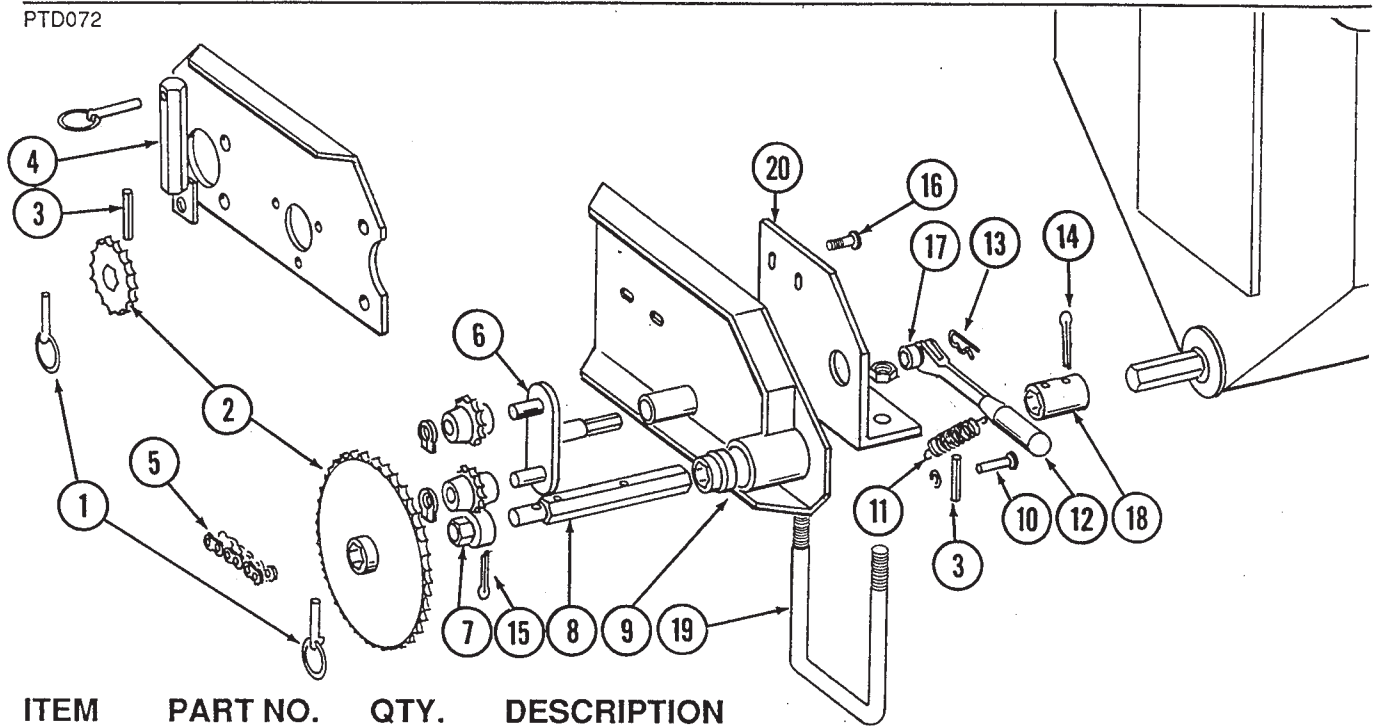

ITEM	PART NO.	QTY.	DESCRIPTION
1.	GD2558	3	Lynch Pin, 1/4"
2.	GA5105	1	Sprocket, 15 Tooth
	GA5107	1	Sprocket, 19 Tooth
	GA5114	1	Sprocket, 30 Tooth
	GA5115	1	Sprocket, 33 Tooth
	GA5194	1	Sprocket, 50 Tooth
3.	G10602	2	Spring Pin, 1/4" x 1 1/2"
4.	GA5229	1	Sprocket Storage Rod
5.	G3310-162	1	Chain, No. 40, 162 Pitch Including Connector Link
	GR0912	-	Connector Link, No. 40
6.	GA5136	1	Idler W/Sprockets And Rings
	GD7426	-	Sprocket
	G10435	-	Ring
7.	GD7127	1	Shear Coupler
8.	GD7870	1	Shaft, 7"
9.	GA6579	1	Plate W/Bearings And Grease Fitting
	GA5116	-	Bearing
	GA5624	-	Extended Bearing
	G10643	-	Grease Fitting, 1/4"-28, 45°
10.	G10408	1	Clevis Pin, 5/16" x 3/4"
	G10409	1	Ring, 5/16"
11.	GD5857	1	Spring
12.	GA4235	1	Ratchet Arm W/Protective Closure
	G10445	-	Protective Closure
13.	G10670	1	Hair Pin Clip, No. 3
14.	G10460	1	Cotter Pin, 1/4" x 2"
	G10462	1	Cotter Pin, 3/16" x 2"
16.	G10574	2	Carriage Bolt, 1/2"-13 x 1 1/4"
	G10216	4	Washer, 1/2" USS
	G10228	2	Lock Washer, 1/2"
	G10102	2	Hex Nut, 1/2"-13
17.	GD6819	1	Sleeve
18.	GD5886	1	Coupler, 1 3/4"
19.	GD1134	1	U-Bolt, 7" x 5" x 5/8"-11
	G10230	2	Lock Washer, 5/8"
	G10104	2	Hex Nut, 5/8"-11
20.	GD9320	1	Mount

DRY FERTILIZER COUPLERS/SHAFTS

RH101190

6 Row 30 Model

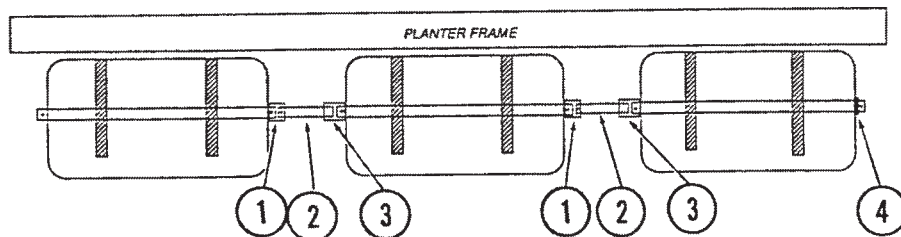

8 Row 30 Model

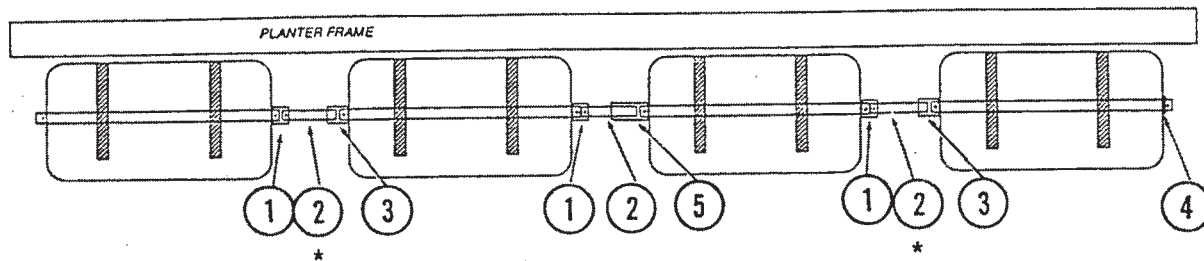

ITEM	PART NO.	DESCRIPTION
1.	GD5886	Coupler, 1 3/4"
2.	GD2548-15.5	Shaft, 15 1/2" (*Trimmed 4" on 8 Row 30 Models With Single Disc Fertilizer Openers)
3.	GD7867	Coupler, 3"
4.	G10233	Machine Bushing
5.	GD9378	Coupler, 12"

DRY FERTILIZER HOPPER AND MOUNTS

DFC009/DFC018/DFC023

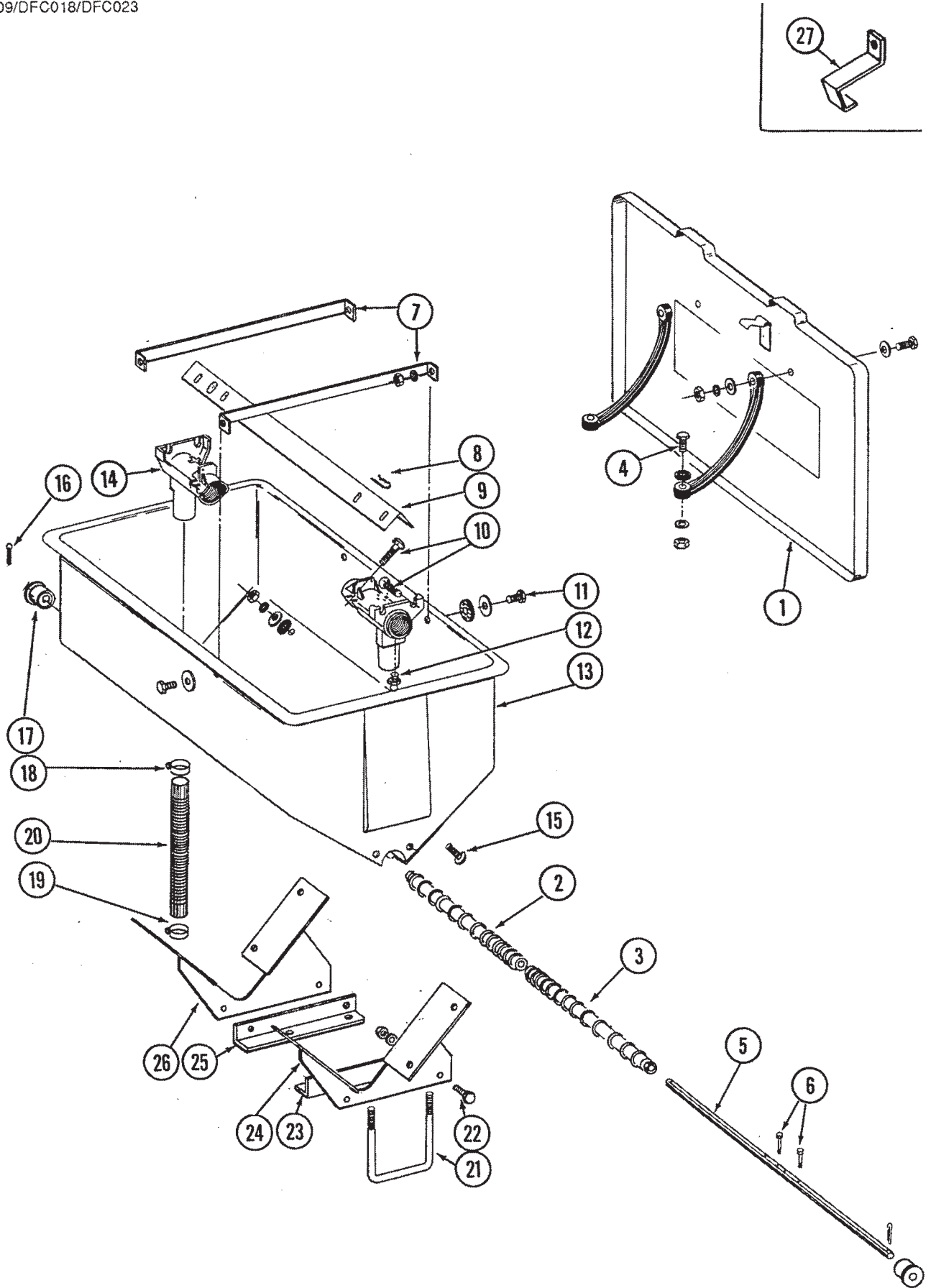

DRY FERTILIZER HOPPER AND MOUNTS

ITEM	PART NO.	QTY.	DESCRIPTION
		(Per Hopper)	
1.	GA0898	1	Lid With Clips, Rivets, Rubber Straps And Hardware
	GD1380	-	Clip
	G10655	-	Rivet, 3/16" x 13/32"
	GD1210	-	Rubber Strap
	G10171	-	Hex Head Cap Screw, 5/16"-18 x 1 1/4"
	G10219	-	Washer, 5/16" USS
	G10232	-	Lock Washer, 5/16"
	G10106	-	Hex Nut, 5/16"-18
2.	GB0198	1	Auger, R.H.
3.	GB0199	1	Auger, L.H.
4.	G10133	4	Hex Head Cap Screw, 5/16"-18 x 1 1/2"
G	G10219	4	Washer, 5/16" USS
	G10232	4	Lock Washer, 5/16"
	G10106	4	Hex Nut, 5/16"-18
5.	GD7848	1	Shaft
6.	G10587	2	Hex Head Cap Screw, 1/4"-20 x 2", Stainless Steel
	G10588	2	Hex Nut, 1/4"-20, Stainless Steel
7.	GD1209	2	Strap
8.	G10670	2	Hair Pin Clip, No. 3
9.	GD1207	1	Baffle
10.	G10303	8	Carriage Bolt, 5/16"-18 x 1", Grade 2
	G10219	8	Washer, 5/16" USS
	G10232	8	Lock Washer, 5/16"
	G10106	8	Hex Nut, 5/16"-18
11.	G10171	4	Hex Head Cap Screw, 5/16"-18 x 1 1/4"
	G10201	4	Special Washer
	GD1213	4	Rubber Washer
	G10232	4	Lock Washer, 5/16"
	G10106	4	Hex Nut, 5/16"-18
12.	G10641	2	Grease Fitting, 1/8" NPT
13.	GD1379	1	Hopper
14.	GD1200	2	Outlet Housing
15.	G10303	4	Carriage Bolt, 5/16"-18 x 1 1/4"
	G10201	4	Special Washer
	GD1213	4	Rubber Washer
	G10232	4	Lock Washer, 5/16"
	G10106	4	Hex Nut, 5/16"-18
16.	G10460	2	Cotter Pin, 1/4" x 2"
17.	GB0200	2	Bearing
18.	G10676	2	Clamp, No. 36
19.	G10672	2	Clamp, No. 28
20.	GD3790	2	Rubber Tube
21.	GD1134	2	U-Bolt, 7" x 5" x 5/8"-11
	G10230	4	Lock Washer, 5/8"
	G10104	4	Hex Nut, 5/8"-11
22.	G10017	4	Hex Head Cap Screw, 1/2"-13 x 1 1/2"
	G10228	4	Lock Washer, 1/2"
	G10102	4	Hex Nut, 1/2"-13
23.	GD9131	1	Angle, L.H.
24.	GA6437	1	Mount, L.H.
25.	GD9132	1	Angle, R.H.
26.	GA6436	1	Mount, R.H.
27.	GD8722	-	Holder (As Required)

LIQUID FERTILIZER TANKS, SADDLES, MOUNTS, HOSES AND FITTINGS

LFC012rev

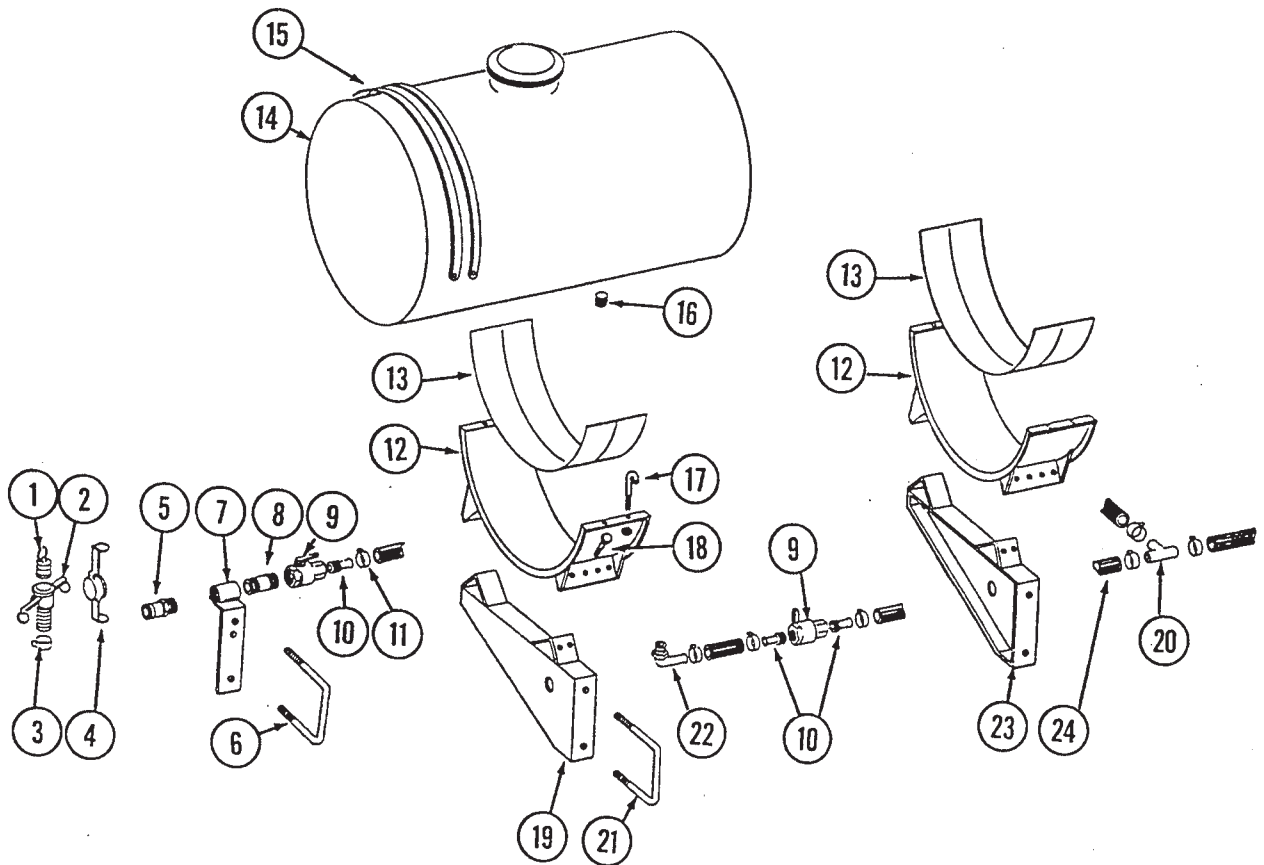

LIQUID FERTILIZER TANKS, SADDLES, MOUNTS, HOSES AND FITTINGS

ITEM	PART NO.	DESCRIPTION
1.	GD1517	Dust Plug
2.	GD1516	Adapter
3.	G10672	Clamp, No. 28
4.	GD1515	Dust Cap, 1 1/4"
5.	GD1514	Adapter
6.	GD8306	U-Bolt, 5" x 7" x 1/2"-13
	G10228	Lock Washer, 1/2"
	G10102	Hex Nut, 1/2"-13
7.	GA5917	Quick Fill Mount
8.	G10619	Pipe Nipple, 1 1/4" x 3"
9.	GA4976	Ball Valve, Full Port
	GR1015	Body O-Ring
	GR1016	Stem O-Ring
	GR1017	Teflon Seat
	GR1018	Ball
	GR1019	Handle
10.	G10626	Adapter, 1 1/4" NPT to 1 1/4" Barb Fitting
11.	G10674	Clamp, No. 24
12.	GA5264	Saddle
13.	GD1862	Pad, 8" x 14'
14.	GD1812	Tank W/Lid and Fittings, 30" x 150 Gallon
	GR0508	1 1/4" Nylon Fitting
	GR0509	Fillwell (Use With R0510)
	GR1005	Fillwell, Threaded (Use With R1006)
	GR0510	Lid, 10" (Use With R0509)
	GR1006	Lid, 10", Thread (Use With R1005)
	GR0513	3/8" Nylon Fitting
15.	GD1520	Band, 30"
16.	G10096	Plug, 3/4" Nylon
17.	GD1337	J-Bolt, 5/16"
	G10109	Lock Nut, 5/16"-18
18.	G10003	Hex Head Cap Screw, 3/8"-16 x 1 1/2"
	G10210	Washer, 3/8" USS
	G10229	Lock Washer, 3/8"
	G10101	Hex Nut, 3/8"-16
19.	GA5799	Saddle Mount
20.	G10633	Tee, 1 1/4"
21.	GD1113	U-Bolt, 5" x 7" x 5/8"-11
	G10230	Lock Washer, 5/8"
	G10104	Hex Nut, 5/8"-11
22.	G10629	Elbow
23.	GA5800	Saddle Mount
24.	G4200-02	Hose, 1 1/4" x 27', 6 Row Models
	G4200-03	Hose, 1 1/4" x 32', 8 Row Models

LIQUID FERTILIZER SQUEEZE PUMP MOUNTING BRACKETS AND DRIVE LINE

LFC009/LFC010/LFC024/PTD074

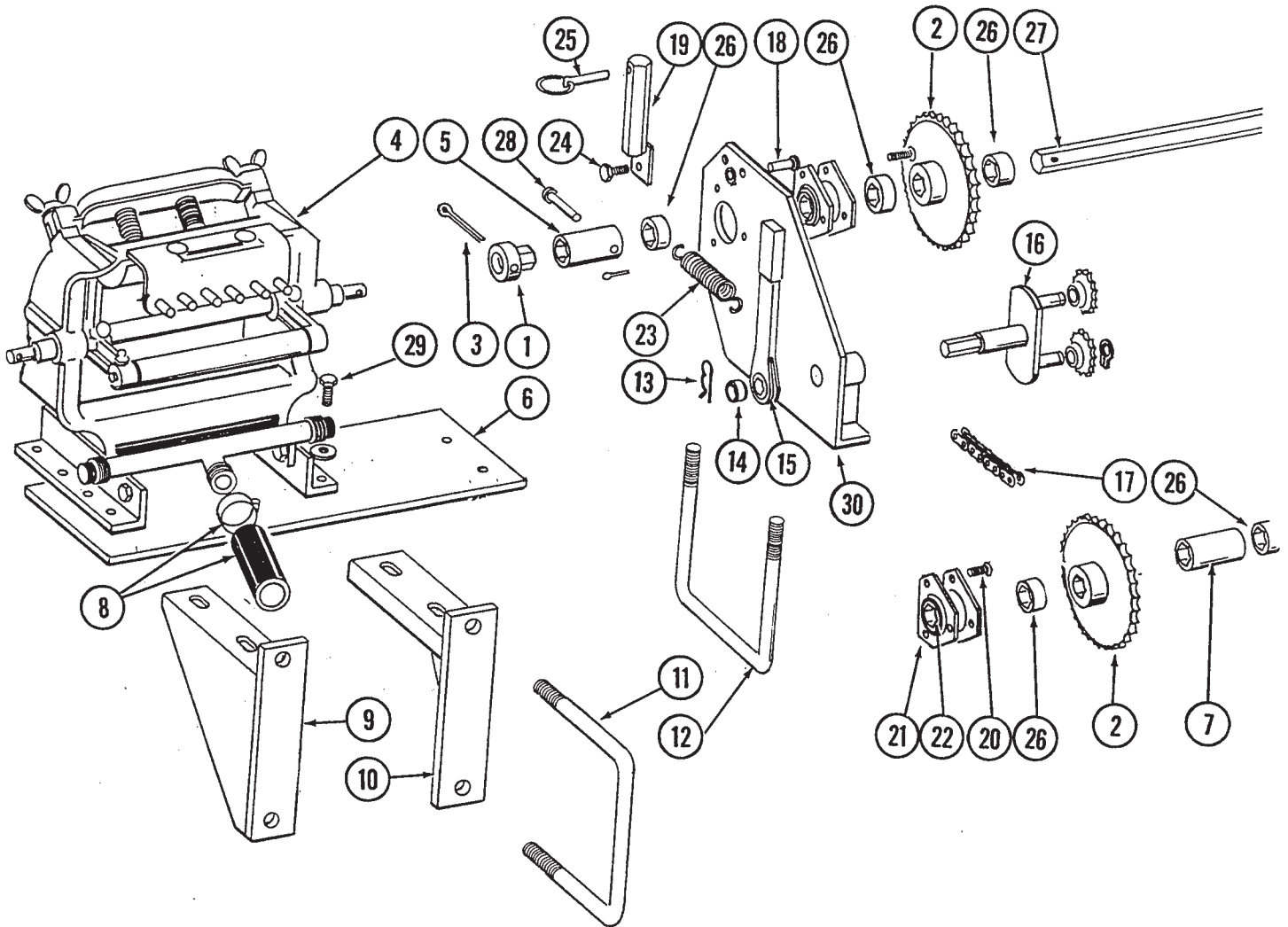

ITEM	PART NO.	QTY.	DESCRIPTION
1.	GD7127	1	Shear Coupler
2.	GA5105	1	Sprocket, 15 Tooth
	GA5107	1	Sprocket, 19 Tooth
	GA6513	1	Sprocket, 32 Tooth
	GA5202	1	Sprocket, 34 Tooth
	GA6514	1	Sprocket, 46 Tooth
	GA6515	-	Sprocket, 62 Tooth (Optional)

LIQUID FERTILIZER SQUEEZE PUMP MOUNTING BRACKETS AND DRIVE LINE

ITEM	PART NO.	QTY.	DESCRIPTION
3.	G10462	1	Cotter Pin, 3/16" x 2"
4.		-	See "Liquid Fertilizer Squeeze Pump"
5.	GD9048	1	Coupler, 2 1/2"
6.	GD6165	-	Plate, 8 Row Only
7.	GD1719	1	Coupler, 4"
8.		-	See "Liquid Fertilizer Tanks, Saddles, Mounts, Hoses And Fittings"
9.	GA4619	1	Pump Mount, L.H.
10.	GA4620	1	Pump Mount, R.H.
11.	GD1113	2	U-Bolt, 5" x 7" x 5/8"-11
	G10230	4	Lock Washer, 5/8"
	G10104	4	Hex Nut, 5/8"-11
12.	GD1134	1	U-Bolt, 7" x 5" x 5/8"-11
	G10230	2	Lock Washer, 5/8"
	G10104	2	Hex Nut, 5/8"-11
13.	G10670	1	Hair Pin Clip, No. 3
14.	GD6819	1	Sleeve
15.	GA4235	1	Ratchet Arm W/Protective Closure
	G10445	-	Protective Closure
16.	GA5136	1	Idler W/Sprockets And Rings
	GD7426	-	Sprocket
	G10435	-	Ring
17.	G3310-176	1	Chain, No. 40, 176 Pitch Including Connector
	GR0912	-	Connector Link, No. 40
18.	G10478	1	Clevis Pin, 5/16" x 1"
	G10409	1	Retaining Ring
19.	GA5229	1	Sprocket Storage Rod
20.	G10303	6	Carriage Bolt, 5/16"-18 x 1"
	G10232	6	Lock Washer, 5/16"
	G10106	6	Hex Nut, 5/16"-18
21.	G3400-01	4	Flangette
22.	G2100-03	2	Bearing, 7/8" Hex Bore, Spherical
23.	GD5857	1	Spring
24.	G10037	1	Hex Head Cap Screw, 1/2"-13 x 1 1/4"
	G10228	1	Lock Washer, 1/2"
	G10102	1	Hex Nut, 1/2"-13
25.	GD2558	1	Lynch Pin, 1/4"
26.	GD0917	5	Lock Collar, 7/8" Hex, Less Set Screws
	G10145	-	Set Screw, 5/16"-18 x 1/2"
27.	GD2548-30	1	Shaft, 30"
28.	G10558	1	Clevis Pin, 5/16" x 1 3/4"
	G10456	1	Cotter Pin, 1/8" x 3/4"
29.	G10004	4	Hex Head Cap Screw, 3/8"-16 x 1 1/4"
	G10210	4	Washer, 3/8" USS
	G10229	4	Lock Washer, 3/8"
	G10101	4	Hex Nut, 3/8"-16
30.	GA6403	1	Drive Plate W/Grease Fitting
	G10641	-	Grease Fitting, 1/8" NPT

LIQUID FERTILIZER SQUEEZE PUMP

6 ROW MODELS

LFC011LFC010

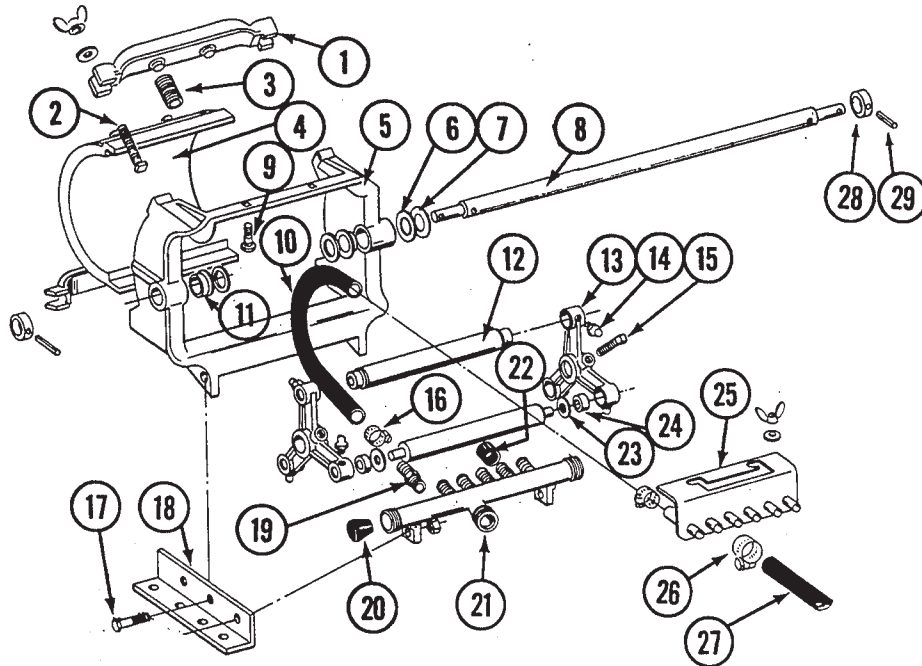

ITEM	PART NO.	QTY.	DESCRIPTION
		(Per Pump)	
1.	GR0216	2	Spring Anchor Bar
2.	G10130	4	Square Head Machine Bolt, 5/16"-18 x 1 3/4"
	G10219	4	Washer, 5/16" USS
	G10144	4	Wing Nut, 5/16"-18
3.	GR0214	4	Spring
4.	GR0212	1	Plate
5.	GR0208	1	Frame
6.	GR0225	2	Shim, 1/32"
7.	GR0226	2	Shim, 3/64"
8.	GD9107	1	Shaft
9.	G10303	2	Carriage Bolt, 5/16"-18 x 1"
	G10219	2	Washer, 5/16" USS
	G10144	2	Wing Nut, 5/16"-18
10.	GR0215	6	Metering Hose, 1/2" x 13"
11.	GR0207	2	Nylon Bushing
12.	GR0233	3	Roller
13.	GR0231	2	Roller Arm
14.	G10640	8	Grease Fitting, 1/4"-28
15.	G10131	2	Set Screw, 5/16"-18 x 3/4"
16.	G10681	12	Clamp, No. 6
17.	G10004	4	Hex Head Cap Screw, 3/8"-16 x 1 1/4"
	G10101	4	Hex Nut, 3/8"-16
18.	GR0213	2	Angle
19.	GR0232	6	Adapter
20.	GR0217	2	Manifold Plug
21.	GR0228	1	Intake Manifold
22.	GR0211	-	Rubber Cap
23.	GR0229	6	Nylon Bushing
24.	GR0230	6	Roller Bearing
25.	GR0224	1	Discharge Manifold
26.	G10673	6	Clamp, No. 8
27.	G4300-04	-	Hose, 1/2" x 50'
28.	GD9109	2	Sleeve
29.	G10718	2	Spring Pin, 5/16" x 1 1/8"
A.	GA6511	-	Squeeze Pump Complete, 6 Rows (Items 1-25 And 28-29)

LIQUID FERTILIZER SQUEEZE PUMP

8 ROW MODELS

LFC010

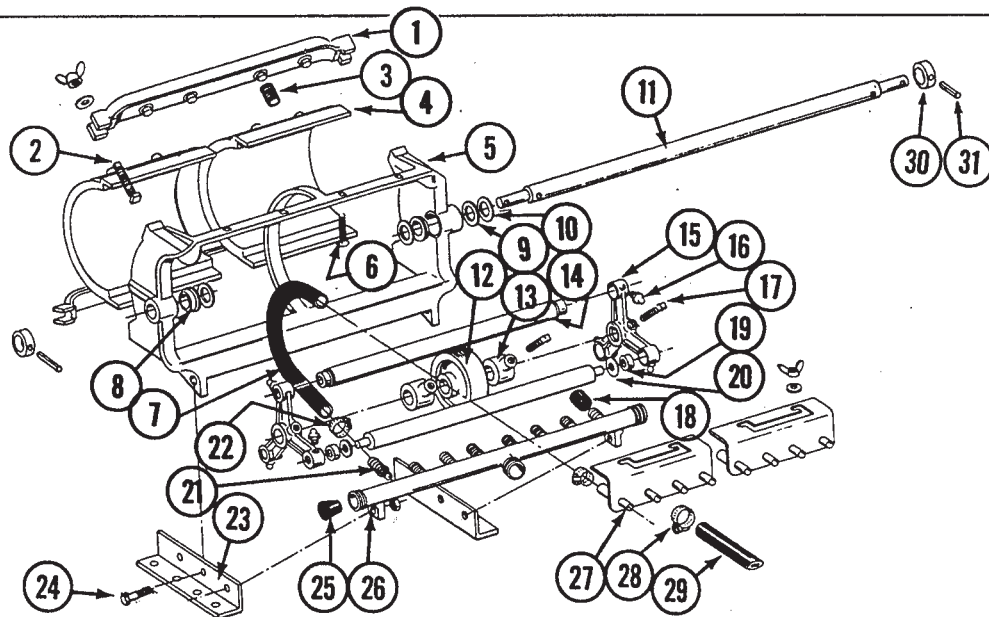

ITEM	PART NO.	QTY.	DESCRIPTION
		(Per Pump)	
1.	GR0221	2	Spring Anchor Bar
2.	G10130	4	Square Head Machine Bolt, 5/16"-18 x 1 3/4"
	G10219	4	Washer, 5/16" USS
	G10144	4	Wing Nut, 5/16"-18
3.	GR0214	8	Spring
4.	GR0212	2	Plate
5.	GR0222	1	Frame
6.	G10303	4	Round Head Machine Bolt, 5/16"-18 x 1"
	G10219	4	Washer, 5/16" USS
	G10144	4	Wing Nut, 5/16"-18
7.	GR0215	8	Metering Hose, 1/2" x 13"
8.	GR0207	2	Nylon Bushing
9.	GR0225	4	Shim, 1/32"
10.	GR0226	4	Shim, 3/64"
11.	GD9108	1	Shaft
12.	GR0281	1	Back Up Roller
13.	GR0282	2	Set Collar
14.	GR0283	3	Roller
15.	GR0231	2	Roller Arm
16.	G10640	8	Grease Fitting, 1/4"-28
17.	G10131	2	Set Screw, 5/16"-18 x 3/4"
18.	GR0211	-	Rubber Cap
19.	GR0230	6	Bearing
20.	GR0229	6	Nylon Washer
21.	GR0232	8	Adapter
22.	G10681	16	Clamp, No. 6
23.	GR0279	1	Angle, Left
	GR0280	1	Angle, Right
24.	G10004	4	Hex Head Cap Screw, 3/8"-16 x 1 1/4"
	G10101	4	Hex Nut, 3/8"-16
25.	GR0217	2	Manifold Plug
26.	GR0284	1	Intake Manifold
27.	GR0236	1	Discharge Manifold
28.	G10673	8	Clamp, No. 8
29.	G4300-05	-	Hose, 1/2" x 100'
30.	GD9109	2	Sleeve
31.	G10718	2	Spring Pin, 5/16" x 1 1/8"
A.	GA6512	-	Squeeze Pump Complete, 8 Rows (Items 1 - 27 And 30-31)

LIQUID FERTILIZER PISTON PUMP MOUNTING BRACKETS AND DRIVE LINE

LFC024/LFC025/LFC026

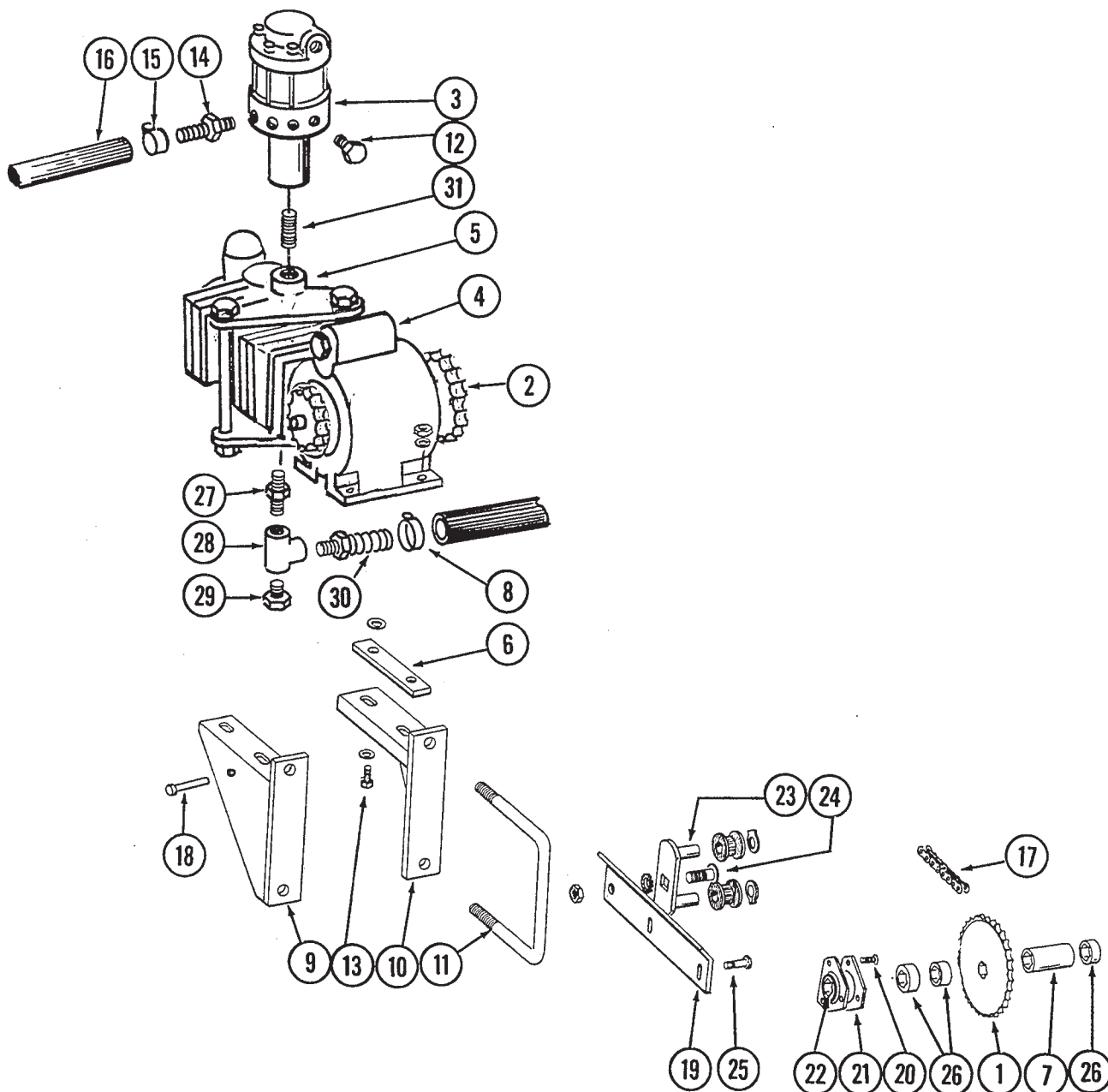

LIQUID FERTILIZER PISTON PUMP MOUNTING BRACKETS AND DRIVE LINE

ITEM	PART NO.	QTY.	DESCRIPTION
1.	GA5194	1	Sprocket, 50 Tooth
2.	GA6509	1	Sprocket W/Set Screw, 23 Tooth
3.		-	See "Liquid Fertilizer Flow Divider"
4.		-	See "Liquid Fertilizer Piston Pump (Crankcase Assembly)"
5.		-	See "Liquid Fertilizer Piston Pump (Cylinder Assembly)"
6.	GD9242	2	Spacer
7.	GD1719	1	Coupler, 4"
8.		-	See "Liquid Fertilizer Tanks, Saddles, Mounts, Hoses And Fittings"
9.	GA4619	1	Pump Mount, L.H.
10.	GA4620	1	Pump Mount, R.H.
11.	GD1113	2	U-Bolt, 5" x 7" x 5/8"-11
	G10230	4	Lock Washer, 5/8"
	G10104	4	Hex Nut, 5/8"-11
12.	G10292	-	Plug, 1/4" NPT
13.	G10048	4	Hex Head Cap Screw, 3/8"-16 x 2"
	G10210	4	Washer, 3/8" USS
	GR1122	4	Mounting Pad
	G10229	4	Lock Washer, 3/8"
	G10101	4	Hex Nut, 3/8"-16
14.	GD8816	-	Hose Barb (As required)
15.	G10673	-	Hose Clamp, No. 8 (As required)
16.	G4300-04	-	Hose, 1/2" x 50', 6 Row
	G4300-05	-	Hose, 1/2" x 100', 8 Row
17.	G3310-152	1	Chain, No. 40, 152 Pitch Including Connector
	GR0912	-	Connector Link, No. 40
18.	G10478	1	Clevis Pin, 5/16" x 1"
	G10409	1	Retaining Ring
	G10669	1	Hair Pin Clip, No. 22
19.	GD9244	1	Idler Mount
20.	G10303	3	Carriage Bolt, 5/16"-18 x 1"
	G10232	3	Lock Washer, 5/16"
	G10106	3	Hex Nut, 5/16"-18
21.	G3400-01	2	Flangette
22.	G2100-03	1	Bearing, 7/8" Hex Bore, Spherical
23.	GA0289	1	Idler W/Spools And Retaining Rings
	GD1067	-	Spool
	G10435	-	Retaining Ring
24.	G10313	1	Carriage Bolt, 1/2"-13 x 1 1/2"
	G10527	1	Lock Washer, 1/2" Int./Ext.
	G10111	1	Lock Nut, 1/2"-13
25.	G10003	2	Hex Head Cap Screw, 3/8"-16 x 1 1/2"
	G10210	2	Washer, 3/8" USS
	G10229	2	Lock Washer, 3/8"
	G10101	2	Hex Nut, 3/8"-16
26.	GD0917	3	Lock Collar, 7/8" Hex, Less Set Screws
	G10145	-	Set Screw, 5/16"-18 x 1/2"
27.	G10728	1	Reducing Bushing
28.	G10719	1	Tee
29.	G10739	1	Pipe Plug
30.	G10626	-	Adapter, 1 1/4" NPT To 1 1/4" Barb Fitting
31.	G10389	1	Pipe Nipple, 3/4" NPT

LIQUID FERTILIZER PISTON PUMP (Crankcase Assembly)

JB-L4400-991/CCU007

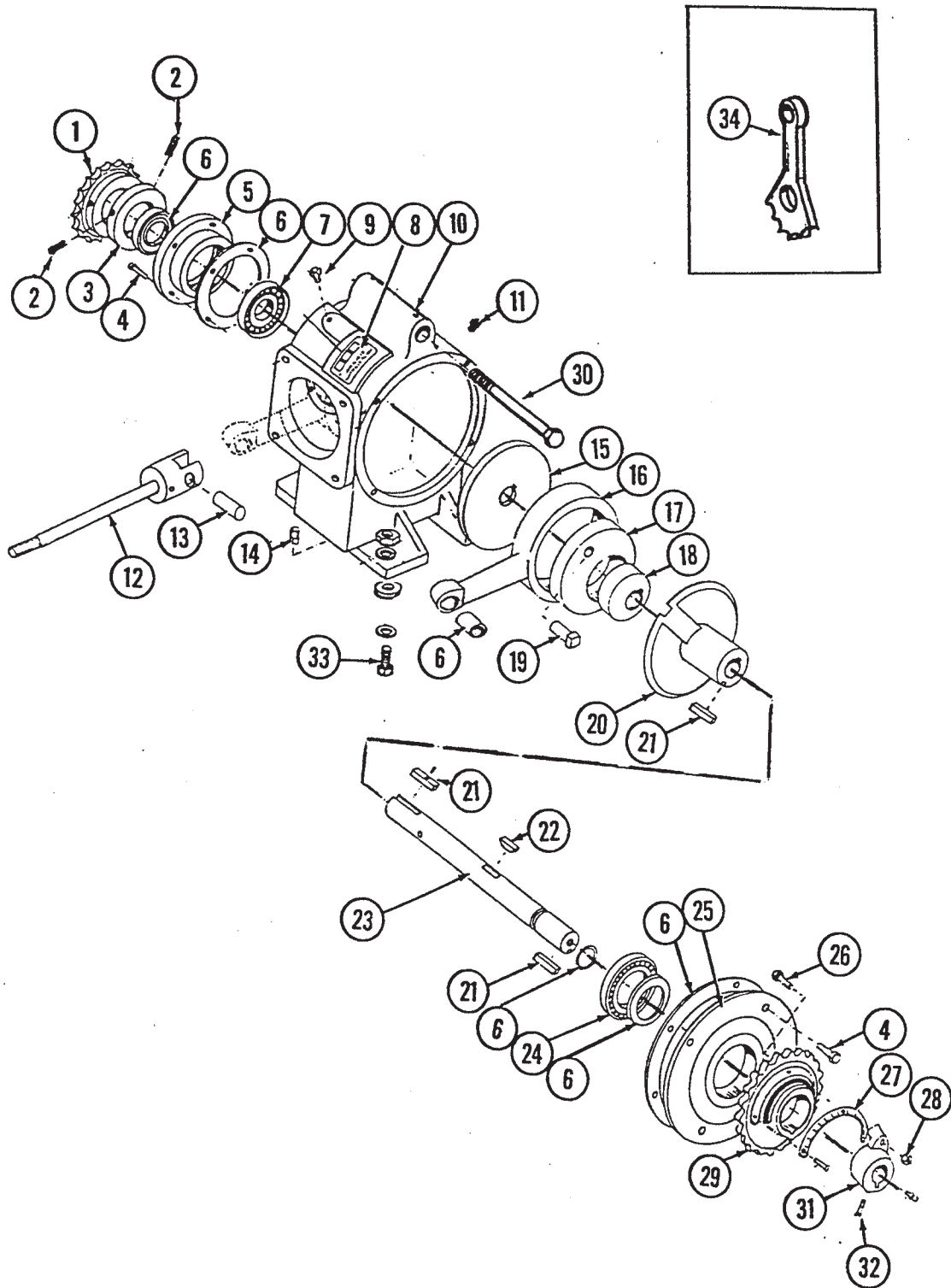

LIQUID FERTILIZER PISTON PUMP (Crankcase Assembly)

ITEM	PART NO.	QTY.	DESCRIPTION
1.		-	See "Liquid Fertilizer Piston Pump Mounting Brackets And Drive Line"
2.	G10688	2	Hex Socket Head Set Screw, 3/8"-16 x 5/8"
3.	GR1147	1	Spacer
4.	G10019	8	Hex Bolt, 5/16"- 18 x 1"
5.	GR1102	1	Housing
6.	GR1173	-	Repair Kit, Also Includes Items 5 On "Liquid Fertilizer Piston Pump (Cylinder Assembly)" Pages
7.	GR1104	1	Bearing
8.	GR1105	1	Name Plate
9.	G10054	2	Hex Bolt, 5/16"-18 x 1/2"
10.	GR1106	1	Crankcase
11.	GR1107	1	Vent Plug
12.		-	See "Liquid Fertilizer Piston Pump (Cylinder Assembly)"
13.		-	See "Liquid Fertilizer Piston Pump (Cylinder Assembly)"
14.	GR1123	3	Plug
15.	GR1108	1	Disc
16.	GR1109	1	Connecting Rod
17.	GR1110	1	Large Eccentric
18.	GR1111	1	Small Eccentric
19.	GR1120	1	Eccentric Pin
20.	GR1119	1	Sleeve
21.	GR1118	3	Setting Arm Key
22.	GR1112	1	Woodruff Key
23.	GR1148	1	Crankshaft
24.	GR1116	1	Bearing
25.	GR1166	1	Cover Plate
26.	GR1167	1	Square Head Bolt, 3/8"-16 x 1 3/4"
27.	GR1168	1	Scale
28.	G10108	1	Lock Nut, 3/8"-16
29.	GR1114	1	Flange
30.	G10318	1	Hex Head Cap Screw, 5/8"-11 x 4 1/2"
	G10104	1	Hex Nut, 5/8"-11
31.	GR1165	1	Arm
32.	G10693	1	Hex Socket Head Set Screw, 5/16"-18 x 3/8"
33.		-	See "Liquid Fertilizer Piston Pump Mounting Brackets And Drive Line"
34.	GR1100	1	Adjustment Wrench
A.	GA6154	1	Piston Pump Complete, Includes Crankcase (Items 2-34) and Cylinder (Items 1-22) Assemblies

LIQUID FERTILIZER PISTON PUMP (Cylinder Assembly)

JB-L4400-991/SKH007

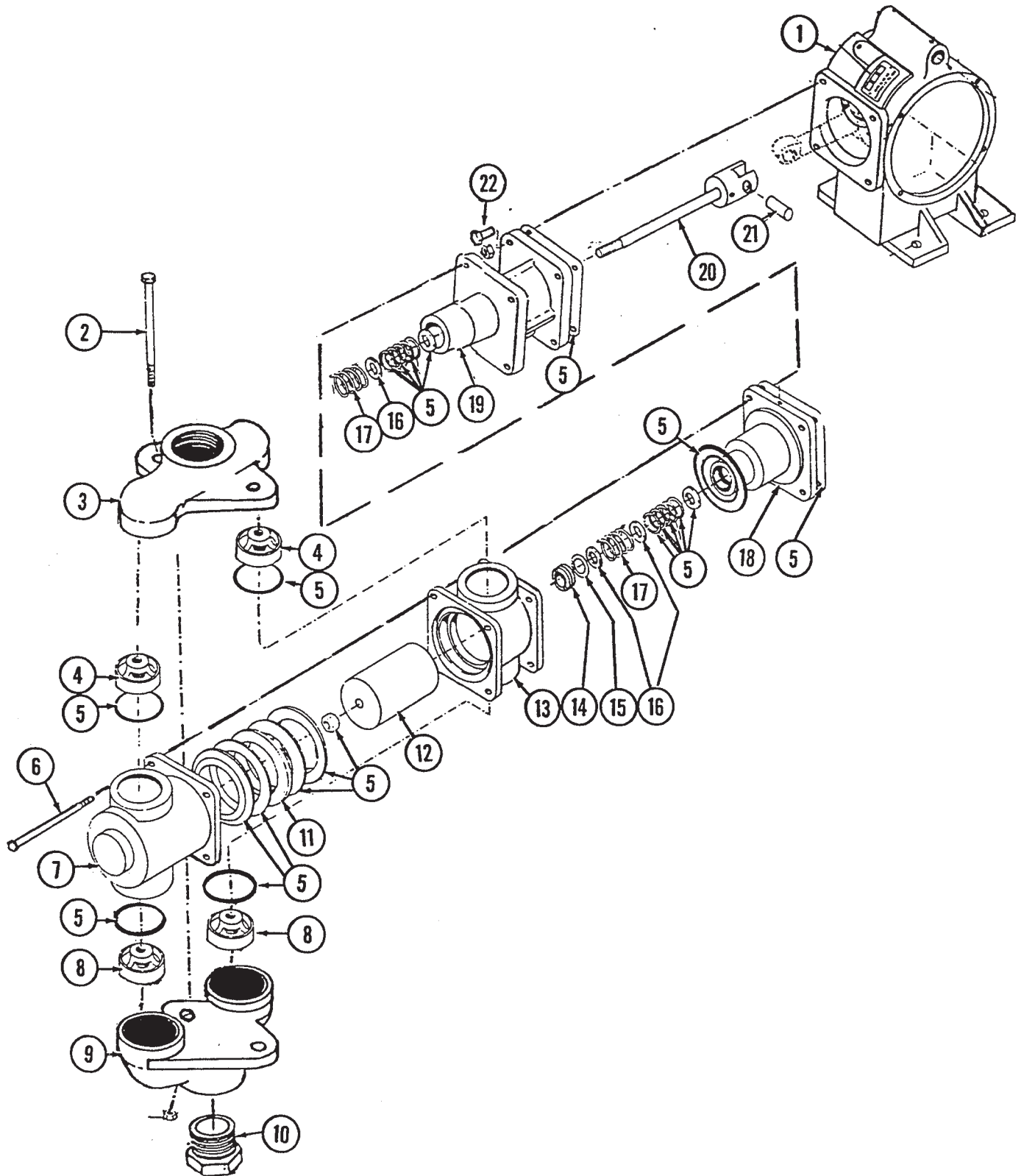

LIQUID FERTILIZER PISTON PUMP (Cylinder Assembly)

ITEM	PART NO.	QTY.	DESCRIPTION
1.		-	See "Liquid Fertilizer Piston Pump (Crankcase Assembly)"
2.	G10686	2	Hex Hex Cap Screw, 3/8"-16 x 8"
	G10101	2	Hex Nut, 3/8"-16
3.	GR1145	1	Discharge Manifold
4.	GR1144	2	Discharge Valve
5.	GR1173	-	Repair Kit , Also Includes Items 6 On "Liquid Fertilizer Piston Pump (Crankcase Assembly)" Pages
6.	G10687	4	Hex Head Cap Screw, 3/8"-16 x 5 1/2"
	G10101	4	Hex Nut, 3/8"-16
7.	GR1143	1	Outboard Cylinder
8.	GR1142	2	Suction Valve
9.	GR1140	1	Suction Manifold
10.		-	See "Liquid Fertilizer Piston Pump Mounting Brackets And Drive Line"
11.	GR1137	1	Flange Packing Washer
12.	GR1136	1	Plunger
13.	GR1135	1	Inboard Cylinder
14.	GR1134	1	Stuffing Box Insert
15.	GR1133	1	Retaining Ring
16.	GR1129	3	Washer
17.	GR1130	2	Packing Spring
18.	GR1132	1	Outboard Stuffing Box
19.	GR1127	1	Crosshead Guide
20.	GR1125	1	Piston Rod
21.	GR1124	1	Pin
22.	G10019	4	Hex Head Cap Screw, 5/16"-18 x 1"

LIQUID FERTILIZER PISTON PUMP FLOW DIVIDER

JB-L2190-991

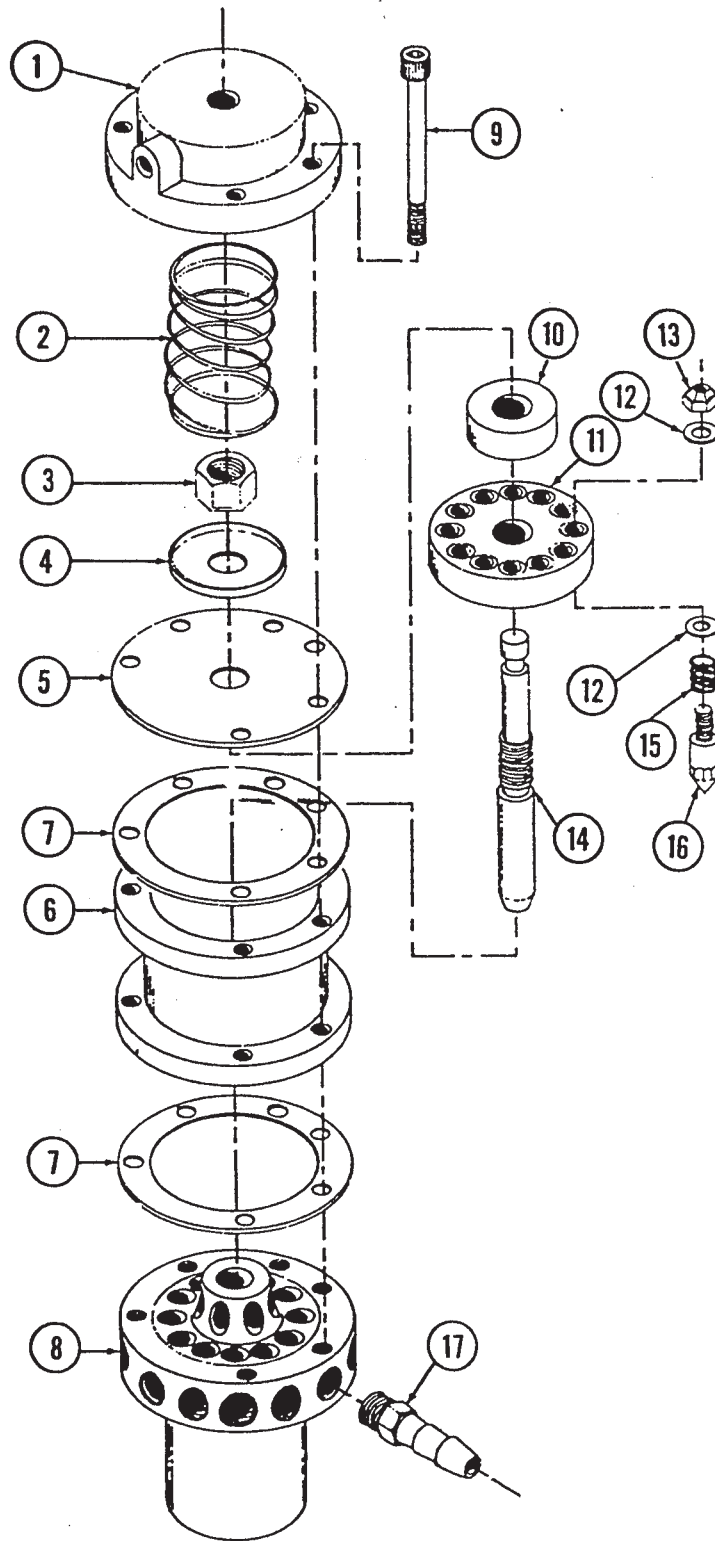

LIQUID FERTILIZER PISTON PUMP FLOW DIVIDER

ITEM	PART NO.	QTY.	DESCRIPTION
1.	GR1150	1	Cap
2.	GR1151	1	Spring
3.	G10358	1	Hex Nut, 9/16"-18
4.	GR1152	1	Plate
5.	GR1153	1	Diaphragm
6.	GR1154	1	Housing
7.	GR1155	2	Gasket
8.	*	-	Manifold
9.	GR1157	6	Socket Screw, 1/4"
10.	GR1158	1	Lock
11.	*	-	Disk
12.	*	-	Stainless Steel Washer
13.	*	-	Valve Nut
14.	GR1162	1	Plunger
15.	*	-	Spring
16.	*	-	Valve
17.		-	See "Liquid Fertilizer Piston Pump Mounting Brackets And Drive Line"
A.	GA6158	-	Liquid Fertilizer Piston Pump Flow Divider Complete

* Factory calibration required. Replacement not recommended. Always be sure timing marks on disk and manifold line up.

DECALS, REFLECTORS AND TIE STRAPS

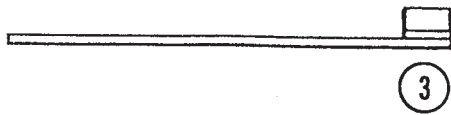

3

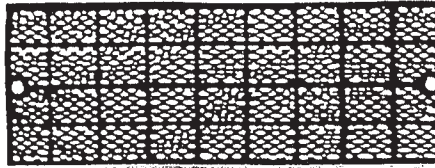

4



5



6

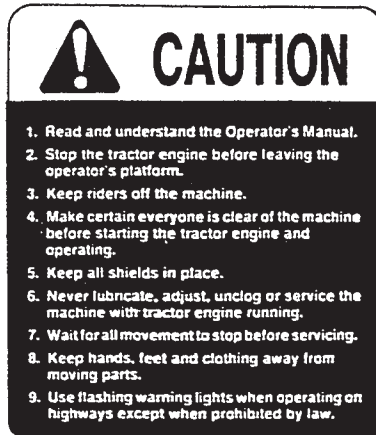

7



8

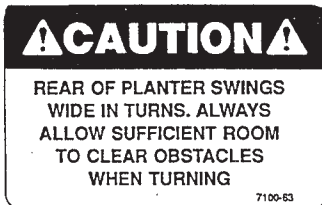

9



10

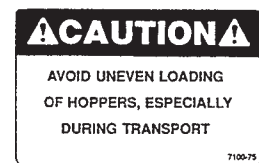

11



12



13



14



15



16



17

DECALS, REFLECTORS AND TIE STRAPS

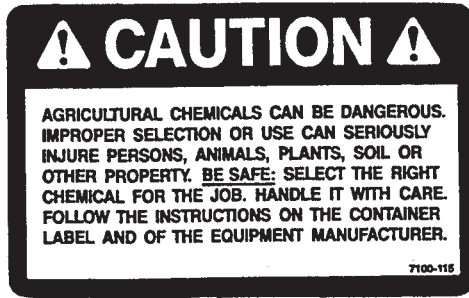

18



19

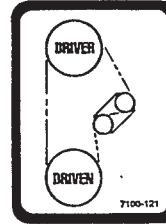

20



21

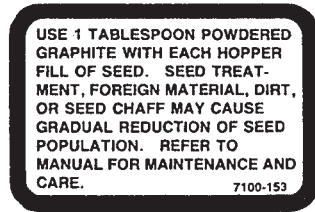

22



23



25



24



26

ITEM	PART NO.	QTY.	DESCRIPTION
1.	GR0155	-	Blue Paint, Aerosol (Not Shown)
	GR0439	-	Blue Paint, Quart (Not Shown)
	GR0440	-	Blue Paint, Gallon (Not Shown)
2.	GR0146	-	Powdered Graphite, 1 Pound (Not Shown)
	GR1179	-	Talc, 2 Pounds (Not Shown)
3.	GD1162	-	Tie Strap, 28"
	GD1512	-	Tie Strap, 6"
	GD2117	-	Tie Strap, 14 1/2"
	GD2984	-	Tie Strap, 33"
4.	G7200-03	4	Reflector, Red
	G7200-04	2	Reflector, Amber
5.	G7100-02	3	Decal, Warning
6.	G7100-42	-	Decal, Warning (2 Per Marker)
7.	G7100-46	1	Decal, Caution
8.	G7100-56	1	Decal, Warning
9.	G7100-63	2	Decal, Caution
10.	G7100-68	4	Decal, Warning
11.	G7100-75	4	Decal, Caution
12.	G7100-83	-	Decal, Warning (1 Per Marker Lockup)
13.	G7100-89	2	Decal, Danger
14.	G7100-90	1	Decal, Warning
15.	G7100-104	2	Decal, KINZE, 3" x 12"
16.	G7100-110	-	Decal, Weekly
17.	G7100-111	-	Decal, Daily
18.	G7100-115	-	Decal, Caution (1 Per Granular Chemical Hopper Lid)
19.	G7100-116	-	Decal, Daily
20.	G7100-121	1	Decal, Transmission
21.	G7100-144	-	Decal, Logo (2 Per Row Unit)
22.	G7100-153	-	Decal, Information (1 Per Brush-type Seed Meter)
23.	G7100-177	1	Decal, Twin-Line®, 3/4" x 3"
24.	G7100-182	-	Decal, Meter Alignment (1 Per Row Unit)
25.	G7100-191	2	Decal, 2500
26.	G7100-194	1	Decal, Instruction

NUMERICAL INDEX

Part No.	Page	Part No.	Page	Part No.	Page
G2100-03	P31, P34, P61, P65	G10001	P34, P49, P53	G10105	P25, P29, P53
G2700-08	P45	G10003	P2, P6, P59, P65	G10106	P5, P15, P17, P27, P31, P35, P57, P61, P65
G2701-08	P45	G10004	P4, P21, P25, P47, P61, P62, P63	G10107	P4, P14, P15, P17, P25, P31, P35, P51
G306-08	P45	G10005	P4, P25, P31	G10108	P3, P21, P25, P31, P52, P53, P67
G3303-96	P21	G10006	P4, P25	G10109	P5, P51, P59
G3303-98	P7	G10007	P53	G10110	P8, P52
G3303-114	P13	G10008	P4, P17, P29, P37, P39	G10111	P6, P14, P15, P17, P21, P51, P52, P53, P65
G3305-01	P19	G10010	P53	G10128	P34, P35
G3310-08	P35	G10012	P17	G10130	P62, P63
G3310-80	P35	G10014	P3	G10131	P62, P63
G3310-89	P35	G10015	P6	G10133	P51, P57
G3310-117	P31	G10016	P6, P29, P35	G10144	P62, P62, P63
G3310-152	P65	G10017	P15, P21, P57	G10145	P33, P35, P49, P61, P65
G3310-162	P54	G10018	P5	G10168	P40
G3310-176	P61	G10019	P7, P51, P67, P69	G10171	P57
G3310-226	P49	G10020	P9	G10197	P17
G3314-40	P13	G10021	P9	G10201	P57
G3400-01	P31, P34, P61, P65	G10022	P9, P13, P27	G10203	P34
G4200-02	P59	G10023	P13, P31	G10204	P3, P7, P51
G4200-03	P59	G10025	P26	G10205	P25, P31, P52, P53
G4300-04	P62, P65	G10026	P29	G10206	P3, P17, P53
G4300-05	P63, P65	G10027	P25	G10207	P13
G6400-06	P43, P45	G10028	P29	G10208	P2
G6400-08	P45	G10031	P27	G10209	P8, P13, P52
G6400-08-06	P45	G10033	P34, P40	G10210	P2, P3, P4, P6, P8, P21, P31, P34, P51, P52, P59, P61, P65
G6400-L-06	P45	G10036	P14, P17, P21	G10213	P3, P51
G6500-08	P45	G10037	P4, P26, P29, P34, P61	G10216	P3, P6, P14, P15, P21, P34, P35, P49, P53, P54
G6500-08-06	P45	G10039	P15, P29, P53	G10217	P17, P23
G6801-08	P45	G10045	P51	G10219	P57, P62, P63
G6801-08-06	P45	G10046	P51	G10220	P53
G7100-02	P73	G10048	P25, P65	G10226	P37, P39
G7100-42	P73	G10049	P52	G10227	P11, P27, P31
G7100-46	P73	G10053	P31, P34	G10228	P3, P4, P17, P21, P25, P26, P29, P34, P35, P37, P39, P40, P49, P51, P53, P54, P57, P59, P61
G7100-56	P73	G10054	P67	G10229	P2, P3, P4, P6, P7, P8, P11, P13, P21, P25, P31, P47, P49, P51, P52, P59, P61, P65
G7100-63	P73	G10055	P17, P52	G10230	P4, P21, P23, P25, P27, P29, P35, P37, P39, P52, P53, P54, P57, P59, P61, P65
G7100-68	P73	G10061	P25	G10231	P25, P26, P29
G7100-75	P73	G10064	P6	G10232	P5, P7, P27, P31,
G7100-83	P73	G10068	P17		
G7100-89	P73	G10069	P5		
G7100-90	P73	G10087	P29		
G7100-104	P73	G10096	P59		
G7100-110	P73	G10100	P53		
G7100-111	P73	G10101	P3, P4, P7, P8, P11, P13, P21, P25, P31, P47, P49, P51, P52, P59, P61, P62, P63, P65, P69		
G7100-115	P73	G10102	P4, P17, P21, P25, P26, P29, P34, P35, P37, P39, P40, P49, P51, P54, P57, P59, P61		
G7100-116	P73	G10103	P6, P11, P27, P31		
G7100-121	P73	G10104	P4, P17, P21, P23, P25, P27, P52, P54, P57, P59, P61, P65, P67		
G7100-144	P73				
G7100-153	P73				
G7100-177	P73				
G7100-182	P73				
G7100-191	P73				
G7100-194	P73				
G7192X	P4				
G7200-03	P73				
G7200-04	P73				
G10001	P2, P25, P31,				

NUMERICAL INDEX

Part No.	Page	Part No.	Page	Part No.	Page
G10232	P35, P51, P57, P61, P65	G10501	P31	G10640	P26, P29, P53, P62, P63
G10233	P31, P35, P49, P55	G10503	P3, P15, P51	G10641	P35, P37, P39, P53, P57, P61
G10235	P31	G10504	P3, P51	G10643	P54
G10236	P25	G10507	P53	G10655	P57
G10237	P53	G10520	P8	G10660	P13
G10239	P25	G10521	P13	G10669	P3, P65
G10266	P27	G10523	P11	G10670	P7, P35, P54, P57, P61
G10269	P27	G10524	P13	G10672	P57, P59
G10289	P27	G10525	P6, P27	G10673	P62, P63, P65
G10292	P65	G10526	P3, P53	G10674	P59
G10303	P3, P57, P61, P62, P63, P65	G10527	P65	G10676	P57
G10304	P3	G10529	P19	G10680	P11
G10305	P3, P7, P13, P19, P51	G10531	P10	G10681	P51, P62, P63
G10306	P11, P31	G10536	P15	G10686	P69
G10307	P2	G10542	P51	G10687	P69
G10308	P19	G10544	P40	G10688	P67
G10309	P7	G10545	P4, P21	G10690	P9
G10310	P8, P11	G10546	P13	G10693	P67
G10311	P13	G10551	P3	G10716	P25
G10312	P7, P13, P31, P35	G10552	P3	G10717	P25
G10313	P65	G10553	P7	G10718	P62, P63
G10318	P15, P67	G10555	P3	G10719	P65
G10322	P53	G10558	P61	G10722	P40
G10323	P9	G10560	P53	G10724	P40
G10328	P2	G10567	P13	G10725	P40
G10358	P71	G10570	P13	G10728	P65
G10384	P3, P21	G10572	P15, P17	G10739	P65
G10389	P65	G10573	P17	GA0167	P40
G10401	P9	G10574	P14, P17, P54	GA0237	P53
G10403	P52	G10581	P17, P49	GA0243	P40
G10408	P54	G10582	P17	GA0245	P40
G10409	P34, P54, P61, P65	G10584	P10	GA0257	P40
G10417	P23	G10585	P15	GA0289	P65
G10418	P23	G10587	P57	GA0308	P51
G10427	P3	G10588	P57	GA0312	P51
G10430	P33	G10592	P53	GA0318	P51
G10435	P3, P13, P21, P35, P54, P61, P65	G10594	P52	GA0320	P51
G10438	P27, P53	G10597	P15	GA0328	P51
G10445	P35, P54, P61	G10599	P52	GA0378	P33
G10451	P3, P51	G10601	P3	GA0485	P11
G10452	P11	G10602	P9, P10, P13, P31, P33, P34, P54	GA0785	P51
G10455	P7	G10603	P5, P6, P9, P10, P53	GA0810	P51
G10456	P53, P61	G10604	P9	GA0811	P2
G10457	P7, P25	G10605	P2	GA0860	P2
G10459	P53	G10609	P13	GA0895	P29
G10460	P33, P35, P37, P39, P54, P57	G10610	P53	GA0898	P57
G10462	P35, P54, P61	G10619	P59	GA0899	P40
G10464	P33	G10620	P3, P7, P9, P13	GA1021	P45
G10470	P9	G10621	P7, P8, P9, P13, P19	GA1023	P45
G10478	P34, P61, P65	G10622	P19	GA1026	P45
G10482	P29	G10626	P59, P65	GA1041	P45
G10499	P51	G10629	P59	GA1055	P45
G10500	P9	G10633	P59	GA1084	P45
		G10637	P13	GA1090	P45
		G10640	P3, P5, P14, P17,	GA1107	P45

NUMERICAL INDEX

Part No.	Page	Part No.	Page	Part No.	Page
GA1141	P45	GA4994	P23	GA5715	P15
GA1153	P45	GA4995	P23	GA5718	P15
GA1194	P45	GA5089	P31	GA5719	P15
GA1195	P45	GA5090	P31	GA5727	P53
GA1369	P51	GA5097	P42	GA5728	P53
GA1676	P40	GA5103	P34, P49	GA5786	P21
GA1677	P40	GA5105	P31, P35, P54, P60	GA5787	P21
GA1678	P40	GA5106	P35, P35	GA5788	P21
GA1679	P40	GA5107	P35, P49, P54, P60	GA5794	P10
GA1720	P4	GA5108	P35	GA5795	P10
GA2007	P7	GA5109	P35	GA5796	P10
GA2008	P13	GA5110	P35	GA5798	P4
GA2012L	P3	GA5111	P35	GA5799	P59
GA2012R	P3	GA5112	P35	GA5800	P59
GA2013	P3	GA5113	P35	GA5834	P10
GA2014	P3, P15, P17, P51	GA5114	P54	GA5846	P21
GA2016	P7	GA5115	P54	GA5873	P47
GA2018	P9	GA5116	P31, P35, P54	GA5874	P47
GA2019	P9	GA5121	P26	GA5876	P47
GA2020	P9	GA5130	P37, P39	GA5877	P47
GA2021	P5	GA5136	P54, P61	GA5880	P3, P47
GA2022	P5, P6, P53	GA5146	P35	GA5881	P47
GA2027	P8	GA5157	P31	GA5884	P47
GA2054	P6	GA5164	P33	GA5887	P52
GA2056	P3, P21	GA5165	P33	GA5906	P7
GA2058	P8	GA5188	P39	GA5917	P59
GA2068	P31	GA5194	P54	GA5982	P10
GA2075	P11	GA5194	P65	GA6020	P42
GA2076	P13	GA5202	P35, P60	GA6027	P10
GA2094	P19	GA5229	P54, P61	GA6038	P10
GA2116	P3, P5	GA5236	P51	GA6056	P6
GA2142	P29	GA5237	P51	GA6154	P67
GA2148	P29	GA5264	P59	GA6158	P71
GA2180	P49	GA5459	P42	GA6168	P10
GA2327	P8	GA5460	P42	GA6182	P10
GA3086	P6	GA5526	P37, P39	GA6184	P10
GA3105	P45	GA5533	P13	GA6187	P10
GA3137	P45	GA5552	P43	GA6349	P41
GA3151	P45	GA5564	P21	GA6350	P41
GA4122	P27	GA5572	P43	GA6360	P29
GA4123	P27	GA5600	P47	GA6397	P27
GA4223	P47	GA5622	P14, P17	GA6398	P27
GA4229	P47	GA5624	P35, P54	GA6402	P25
GA4230	P47	GA5625	P14	GA6403	P61
GA4235	P35, P54, P61	GA5628	P35	GA6404	P24
GA4286	P52	GA5629	P35	GA6408	P52
GA4287	P52	GA5630	P17	GA6409	P37, P39
GA4309	P42	GA5631	P17	GA6415	P31
GA4431	P27	GA5635	P17	GA6416	P29
GA4444	P13	GA5636	P17	GA6417	P31
GA4470	P34	GA5637	P17	GA6418	P24
GA4619	P61, P65	GA5640	P14, P17	GA6420	P25
GA4620	P61, P65	GA5643	P17	GA6422	P25
GA4693	P29	GA5651	P4	GA6428	P29
GA4822	P7	GA5698	P10	GA6435	P29
GA4976	P59	GA5699	P10	GA6436	P57

NUMERICAL INDEX

Part No.	Page	Part No.	Page	Part No.	Page
GA6437	P57	GB0213	P53	GD1085	P6
GA6438	P43	GB0218	P4, P17, P25, P31, P52	GD1086	P5
GA6440	P26	GB0227	P14, P17	GD1089	P13
GA6442	P37	GB0230	P26	GD1090	P11
GA6476	P11	GB0234	P26	GD1104	P53
GA6478	P10	GD0453-02	P37	GD1109	P4
GA6496	P29	GD0453-03	P39	GD1110	P3
GA6497	P26	GD0453-06	P37	GD1111	P6
GA6498	P25	GD0487	P51		P4, P21, P27, P52,
GA6509	P65	GD0652	P37, P39	GD1113	P59, P61, P65
GA6511	P62	GD0740	P25	GD1115L	P11
GA6512	P63	GD0746	P40	GD1115R	P11
GA6513	P60	GD0840	P40	GD1116	P11
GA6514	P60	GD0914-155	P49	GD1118	P11
GA6515	P60	GD0914-215	P49	GD1120	P2
GA6522	P41	GD0917	P33, P35, P49,	GD1121	P8
GA6523	P41		P61, P65	GD1128	P11
GA6524	P41	GD0962	P51	GD1130	P3
GA6525	P41	GD0971-04	P51	GD1132	P15, P17, P51
GA6529	P29	GD0971-14	P51	GD1134	P54, P57, P61
GA6579	P54	GD0973	P5	GD1138	P51
GA6585	P37, P39	GD1026	P3, P21, P31	GD1143	P19
GA6586	P37, P39	GD1027	P2	GD1144	P19
GA6608	P25	GD1030	P3, P51	GD1145	P19
GA6623	P24	GD1031	P3	GD1162	P73
GA6633	P10	GD1033	P3	GD1200	P57
GB0102	P2	GD1035	P7	GD1207	P57
GB0103	P3	GD1036	P7	GD1209	P57
GB0104	P3	GD1037	P7	GD1210	P57
GB0105	P3	GD1039	P9	GD1213	P57
GB0107	P7	GD1040	P9	GD1255	P33
GB0108	P7	GD1041	P9	GD1256	P33
GB0109	P7	GD1042	P9	GD1323	P11
GB0110	P9	GD1044	P9	GD1337	P59
GB0111	P9	GD1045	P9	GD1353	P5
GB0113	P6	GD1046	P9	GD1379	P57
GB0115	P13	GD1048	P5, P53	GD1380	P57
GB0116	P13	GD1051L	P8	GD1512	P73
GB0118	P5, P53	GD1051R	P8	GD1514	P59
GB0120	P9	GD1053	P8	GD1515	P59
GB0121	P13	GD1054	P8	GD1516	P59
GB0134	P51	GD1055	P8	GD1517	P59
GB0181	P23	GD1056	P13	GD1520	P59
GB0183	P13	GD1058	P13	GD1657	P51
GB0184	P13	GD1059L	P13	GD1673	P51
GB0186	P4, P21	GD1059R	P13	GD1719	P61
GB0195	P15, P17	GD1060	P13	GD1719	P65
GB0196	P17	GD1061	P13	GD1755	P10
GB0198	P57	GD1063	P13	GD1797	P51
GB0199	P57	GD1065	P2	GD1812	P59
GB0200	P57	GD1066	P3	GD1862	P59
GB0205	P52	GD1067	P65	GD2115	P53
GB0206	P53	GD1072	P13	GD2117	P47, P73
GB0209	P52	GD1081	P11	GD2128	P7, P21
GB0210	P52	GD1082	P11	GD2134	P21
GB0212	P53	GD1083	P9	GD2161	P37, P39

NUMERICAL INDEX

Part No.	Page	Part No.	Page	Part No.	Page
GD2199	P27	GD6957	P29	GD8239	P53
GD2423	P11	GD6958	P29	GD8247	P52
GD2460	P19	GD7120	P42	GD8249	P4, P21
GD2548-15.5	P55	GD7122	P42	GD8276	P53
GD2548-30	P61	GD7124	P42	GD8306	P49, P59
GD2558	P35, P54, P61	GD7127	P35, P54, P60	GD8307	P15, P17
GD2589	P51	GD7137	P25	GD8308	P53
GD2597	P40	GD7140	P23	GD8458	P7, P13
GD2721	P37, P39	GD7148	P13	GD8722	P55
GD2734-01	P35	GD7258	P13	GD8750	P13
GD2864	P11	GD7426	P3, P13, P21, P31, P35, P54, P61	GD8751	P47
GD2947	P11			GD8770	P47
GD2971-09	P25	GD7587	P13	GD8771	P47
GD2984	P73	GD7588	P13	GD8778	P10
GD3180-03	P25	GD7589	P13	GD8815	P53
GD3214	P37, P39	GD7591	P13	GD8816	P65
GD3389	P29	GD7592	P13	GD8843	P14, P17
GD3398	P29	GD7618	P7	GD8844	P14, P17
GD3790	P57	GD7619	P4	GD9046	P25
GD4086	P45	GD7626	P21	GD9047	P35
GD4167	P29	GD7627	P21	GD9048	P61
GD4632	P42	GD7803	P14	GD9051	P29
GD4743	P25	GD7803	P17	GD9052	P26
GD4850	P53	GD7804	P14, P17	GD9077	P33
GD4887-03	P35	GD7805	P4, P15, P17, P25	GD9078	P33
GD4888	P53	GD7811	P17	GD9093	P26
GD5752	P31	GD7815	P17	GD9106	P49
GD5753	P31	GD7816	P17	GD9107	P62
GD5756	P31, P34	GD7817-01	P15, P17	GD9108	P63
GD5797	P31	GD7817-04	P15, P17	GD9109	P62, P63
GD5824	P34	GD7817-09	P17	GD9121	P29
GD5827	P31, P34	GD7818	P17	GD9122	P29
GD5829	P34	GD7822	P35	GD9123	P29
GD5830	P34	GD7823	P15, P17	GD9124	P29
GD5835	P35	GD7831	P17	GD9129-01	P25
GD5857	P25, P31, P34, P54, P61	GD7848	P57	GD9130	P29
GD5860	P31	GD7867	P55	GD9131	P57
GD5875	P25	GD7870	P54	GD9132	P57
GD5886	P33, P54, P55	GD7878	P10	GD9143	P26
GD5887-165	P33	GD7888	P29	GD9227	P25
GD5887-225	P33	GD7889	P15	GD9229	P49
GD5892	P25	GD7890	P15	GD9238	P41
GD5949	P42	GD7900	P52	GD9239	P41
GD5951	P41	GD7904-02	P53	GD9241	P41
GD6161	P21	GD7907	P53	GD9242	P65
GD6165	P61	GD7908	P53	GD9244	P65
GD6177	P29	GD7911	P53	GD9254	P14, P17
GD6291	P47	GD7912	P52	GD9320	P54
GD6501	P9	GD7962	P53	GD9378	P55
GD6533	P3	GD8030	P53	GR0146	P73
GD6551	P35	GD8031	P53	GR0150	P40
GD6553	P52	GD8214	P53	GR0151	P40
GD6574	P41	GD8218	P53	GR0155	P73
GD6783	P27	GD8224	P53	GR0188	P52
GD6793	P35	GD8237	P10	GR0193	P26, P29
GD6819	P35, P54, P61	GD8238	P53	GR0196	P7, P13, P21

NUMERICAL INDEX

Part No.	Page	Part No.	Page	Part No.	Page
GR0207	P62, P63	GR0971	P27	GR1122	P65
GR0208	P62	GR0972	P27	GR1123	P67
GR0211	P62, P63	GR0983	P41	GR1124	P69
GR0212	P62, P63	GR0999	P42	GR1125	P69
GR0213	P62	GR1001	P42	GR1127	P69
GR0214	P62, P63	GR1005	P59	GR1129	P69
GR0215	P62, P63	GR1006	P59	GR1130	P69
GR0216	P62	GR1015	P59	GR1132	P69
GR0217	P62, P63	GR1016	P59	GR1133	P69
GR0221	P63	GR1017	P59	GR1134	P69
GR0222	P63	GR1018	P59	GR1135	P69
GR0224	P62	GR1019	P59	GR1136	P69
GR0225	P62, P63	GR1032	P43	GR1137	P69
GR0226	P62, P63	GR1033	P43	GR1140	P69
GR0228	P62	GR1034	P43	GR1142	P69
GR0229	P62, P63	GR1035	P43	GR1143	P69
GR0230	P62, P63	GR1036	P43	GR1144	P69
GR0231	P63	GR1037	P43	GR1145	P69
GR0232	P62, P63	GR1038	P43	GR1147	P67
GR0233	P62	GR1039	P43	GR1148	P67
GR0236	P63	GR1040	P43	GR1150	P71
GR0270	P29	GR1041	P43	GR1151	P71
GR0279	P63	GR1042	P43	GR1152	P71
GR0280	P63	GR1043	P43	GR1153	P71
GR0281	P63	GR1044	P43	GR1154	P71
GR0282	P63	GR1045	P43	GR1155	P71
GR0283	P63	GR1046	P43	GR1157	P71
GR0284	P63	GR1047	P43	GR1158	P71
GR0321	P62	GR1048	P43	GR1162	P71
GR0375	P26, P29	GR1062	P3, P47	GR1165	P67
GR0434	P29	GR1077	P47	GR1166	P67
GR0439	P73	GR1078	P47	GR1167	P67
GR0440	P73	GR1079	P47	GR1168	P67
GR0508	P59	GR1080	P47	GR1173	P67
GR0509	P59	GR1081	P47	GR1173	P69
GR0510	P59	GR1083	P47	GR1177	P43
GR0513	P59	GR1084	P47	GR1178	P43
GR0515	P23	GR1085	P47	GR1179	P73
GR0516	P23	GR1087	P3, P47	GR1180	P6
GR0517	P23	GR1096	P43	GR1183	P41
GR0582	P47	GR1100	P67	GR1184	P41
GR0583	P47	GR1102	P67	GR1185	P41
GR0594	P47	GR1104	P67		
GR0595	P47	GR1105	P67		
GR0664	P9	GR1106	P67		
GR0676	P47	GR1107	P67		
GR0866	P47	GR1108	P67		
GR0911	P31, P35	GR1109	P67		
GR0912	P31, P35, P49, P54, P61, P65	GR1110	P67		
GR0927	P42	GR1111	P67		
GR0933	P9	GR1112	P67		
GR0959	P42	GR1114	P67		
GR0968	P27	GR1116	P67		
GR0969	P27	GR1118	P67		
GR0970	P27	GR1119	P67		
		GR1120	P67		